

# Renewable Energy Technology Characterizations

TR-109496

Topical Report, December 1997

Prepared by

Office of Utility Technologies,  
Energy Efficiency and Renewable Energy,  
U.S. Department of Energy  
1000 Independence Avenue  
Washington, D.C. 20585

and

EPRI  
3412 Hillview Avenue  
Palo Alto, California 94304

Prepared for

**EPRI**

and

**U.S. Department of Energy**

EPRI Project Manager

E.A. DeMeo

Generation Group

U.S. Department of Energy Project Manager

J.F. Galdo

Energy Efficiency and Renewable Energy

## **DISCLAIMER OF WARRANTIES AND LIMITATION OF LIABILITIES**

This report was prepared by the organization(s) named below as an account of work sponsored or cosponsored by the Electric Power Research Institute, Inc. (EPRI). Neither EPRI, any member of EPRI, any cosponsor, the organization(s) below, nor any person acting on behalf of any of them:

(A) Makes any warranty or representation whatsoever, express or implied, (I) with respect to the use of any information, apparatus, method, process, or similar item disclosed in this report, including merchantability and fitness for a particular purpose, or (II) that such use does not infringe on or interfere with privately owned rights, including any party's intellectual property, or (III) that this report is suitable to any particular user's circumstance; or

(B) Assumes responsibility for any damages or other liability whatsoever (including any consequential damages, even if EPRI or any EPRI representative has been advised of the possibility of such damages) resulting from your selection or use of this report or any information, apparatus, method, process, or similar item disclosed in the report.

Organizations that prepared the report

**EPRI**

**U.S. Department of Energy**

Electric Power Research Institute and EPRI are registered service marks of EPRI. Unlimited copying permissible.  
Powering Progress is a service mark of EPRI.

Copyright © 1997 Electric Power Research Institute, Inc. and U.S. Department of Energy. All rights reserved.

## REPORT SUMMARY

---

Renewable energy technologies span the range from developmental to commercially available. Some can make significant contributions now to electricity supply with zero or reduced environmental emissions. This report describes the technical and economic status of the major emerging renewable options and offers projections for their future performance and cost.

### **Background**

Since 1989, the U.S. Department of Energy (DOE) has been developing descriptions of the renewable power technologies for internal program planning and support purposes. Similarly, EPRI has maintained an ongoing perspective on these technologies, and has addressed status and projections for a number of them in its Technical Assessment Guide, TAG™. In late 1996, EPRI and DOE's Office of Utility Technologies embarked on an effort to develop a consensus document on the status, developmental needs, and outlook for these technologies. This effort has been carried out through most of 1997, culminating in this jointly prepared document.

### **Objective**

To provide an objective assessment and description of the renewable power technologies, including current capabilities and future potential, for use by the electricity industry and energy and policy analysts and planners.

### **Approach**

Building on the best available information and experience from many years of direct involvement in the development and assessment of renewable energy technologies, experts from DOE, its national laboratories, and support organizations prepared characterizations of the major renewable technologies. EPRI technical staff in the area of renewables and selected outside reviewers subjected these characterizations to an in-depth review and discussed them at length in two technical workshops. The characterizations were then revised to reflect discussions at and subsequent to the workshops, resulting in this consensus document. In some cases, EPRI staff contributed material for introductory sections.

### **Results**

These technology characterizations provide descriptions of the leading renewable technologies and discussions of current capabilities in terms of system performance and cost. The report provides projections of future performance and costs based on the assumption of continuing development support and the successful resolution of unresolved issues. It also discusses the issues and activities necessary to address these unresolved issues. Costs and cost estimates are presented in terms that allow individuals to perform their own financial analyses using methods appropriate to their own situations and needs. In addition, levelized energy cost estimates are offered.

### **EPRI Perspective**

A great deal of marketing and promotional material is available on the renewable energy technologies. Credible, objective descriptions have been difficult to obtain. For the first time, this document offers descriptions representing consensus among technology development managers and knowledgeable individuals who are not involved directly in the commercial promotion of renewables. Collectively, the DOE and EPRI staff involved believe the information presented in this document provides a sound basis for deployment, development, program planning, and policy analysis for the next several years. EPRI and DOE plan to update and add to this information base on a periodic basis.

**TR-109496**

**Interest Categories**

Wind

Solar

Biomass

Energy storage

**Key Words**

Wind power

Solar power

Biomass power

Geothermal power

Technology assessment

Energy storage

## ABSTRACT

---

An increasing national interest in the use of renewable energy for electricity generation has stimulated a need for carefully prepared data on present and projected costs and performance of current and emerging renewable technology options. This document was prepared jointly by the U.S. Department of Energy and EPRI to address this need. It represents a consensus perspective on 12 different configurations of biomass, geothermal, photovoltaic, solar thermal, and wind technologies. It also provides data on battery storage systems for use in conjunction with renewable energy systems. In addition, various approaches to analyzing project financial attractiveness are presented. This document is designed for use by electric-utility and power-project planners, energy policy analysts, and technology R&D planners.

## ACKNOWLEDGMENTS

---

This first edition of the *Renewable Energy Technology Characterizations* was prepared through a joint effort of the Electric Power Research Institute and the Office of Utility Technologies within the U.S. Department of Energy. Overall project management was provided by Joe Galdo (DOE/OUT), with support from DOE program managers including Lynne Gillette (Biomass), Ray Fortuna, (Geothermal), Jeff Mazer (Photovoltaics), Tom Rueckert (Solar Thermal), Jack Cadogan (Wind) and Christine Platt (Storage). Contributions were made by the following authors:

### **Introduction and Overview**

Ed DeMeo, Electric Power Research Institute  
Tom Schweizer, Princeton Economic Research, Inc.

### **Biomass**

Richard Bain, National Renewable Energy Laboratory  
Kevin Craig, National Renewable Energy Laboratory  
Kevin Comer, Antares Group, Inc.

### **Geothermal**

Dan Entingh, Princeton Economic Research, Inc.  
Lynn McLarty, Princeton Economic Research, Inc.

### **Photovoltaics**

James Gee, Sandia National Laboratory  
Ken Zweibel, National Renewable Energy Laboratory  
Bob McConnell, National Renewable Energy Laboratory  
Terry Peterson, Electric Power Research Institute

### **Solar Thermal**

Rich Diver, Sandia National Laboratory  
Greg Kolb, Sandia National Laboratory  
Hank Price, National Renewable Energy Laboratory

### **Wind**

Joe Cohen and Bertrand Johnson, Princeton Economic Research, Inc.  
Brian Parsons, National Renewable Energy Laboratory

### **Storage**

Mindi Farber, Energetics, Inc.  
Paul Butler, Sandia National Laboratories

### **Finance**

Kathy George, Princeton Economic Research, Inc.  
Tom Schweizer, Princeton Economic Research, Inc.

Critical review of draft material was performed by the following EPRI staff, under the general coordination of Ed DeMeo:

Biomass: Evan Hughes, George Booras, Neville Holt  
Geothermal: Evan Hughes, Jim Birk  
Photovoltaics: Terry Peterson, Frank Goodman  
Solar Thermal: Ed DeMeo, Terry Peterson  
Wind: Chuck McGowin, Ed DeMeo  
Energy Storage: Steve Eckroad, Jim Birk, Frank Goodman  
Finance: Chuck McGowin, Ram Ramachandran

In addition to the EPRI reviews listed above, the authors wish to thank the following individuals for review of and/or contributions toward written materials during various stages of document development: Larry Goldstein and Scott Wright (National Renewable Energy Laboratory), Ray Dracker (Bechtel), Kelly Beninga (Science Applications International Corp.), David Kearny (Kearny Associates), Gilbert Cohen (KJC Operating Company), Philip Symons (Electrochemical Engineering Consultants, Inc.), Don Brown (Los Alamos National Laboratory), Dave Duchane (Los Alamos National Laboratory), and Alex Maish (Sandia National Laboratories).

Document preparation and editing were performed by staff at Princeton Economic Research, Inc., including Tom Schweizer, Mike Pendleton, Kathy George, and Jason Garrison; these staff also participated in the technical review process.

# CONTENTS

---

Chapter	Page
<b>1 Introduction and Overview</b> .....	1-1
<b>2 Biomass</b>	
Overview of Biomass Technologies .....	2-1
Gasification-Based Biomass	
1.0 System Description .....	2-7
2.0 System Application, Benefits, and Impacts .....	2-10
3.0 Technology Assumptions and Issues .....	2-11
4.0 Performance and Cost .....	2-12
4.1 Evolution Overview .....	2-15
4.2 Performance and Cost Discussion .....	2-15
5.0 Land, Water, and Critical Materials Requirements .....	2-18
6.0 References .....	2-19
Direct-Fired Biomass	
1.0 System Description .....	2-22
2.0 System Application, Benefits, and Impacts .....	2-24
3.0 Technology Assumptions and Issues .....	2-25
4.0 Performance and Cost .....	2-26
4.1 Evolution Overview .....	2-26
4.2 Performance and Cost Discussion .....	2-31
5.0 Land, Water, and Critical Materials Requirements .....	2-32
6.0 References .....	2-33
Biomass Co-Firing	
1.0 System Description .....	2-35
2.0 System Application, Benefits, and Impacts .....	2-36
3.0 Technology Assumptions and Issues .....	2-38
4.0 Performance and Cost .....	2-40
4.1 Evolution Overview .....	2-40
4.2 Performance and Cost Discussion .....	2-40
5.0 Land, Water, and Critical Materials Requirements .....	2-47
6.0 References .....	2-49
<b>3 Geothermal</b>	
Overview of Geothermal Technologies .....	3-1
Geothermal Hydrothermal	
1.0 System Description .....	3-6
2.0 System Application, Benefits, and Impacts .....	3-9
3.0 Technology Assumptions and Issues .....	3-10



4.0 Performance and Cost .....	3-12
4.1 Evolution Overview .....	3-12
4.2 Performance and Cost Discussion .....	3-16
5.0 Land, Water, and Critical Materials Requirements .....	3-22
6.0 References .....	3-26

#### Geothermal Hot Dry Rock

1.0 System Description .....	3-29
2.0 System Application, Benefits, and Impacts .....	3-31
3.0 Technology Assumptions and Issues .....	3-33
4.0 Performance and Cost .....	3-35
4.1 Evolution Overview .....	3-38
4.2 Performance and Cost Discussion .....	3-38
5.0 Land, Water, and Critical Materials Requirements .....	3-43
6.0 References .....	3-45

## 4 Photovoltaics

Overview of Photovoltaic Technologies .....	4-1
---	-----

#### Residential Photovoltaics

1.0 System Description .....	4-5
2.0 System Application, Benefits, and Impacts .....	4-6
3.0 Technology Assumptions and Issues .....	4-7
4.0 Performance and Cost .....	4-8
4.1 Evolution Overview .....	4-8
4.2 Performance and Cost Discussion .....	4-11
5.0 Land, Water, and Critical Materials Requirements .....	4-13
6.0 References .....	4-15

#### Utility-Scale Flat-Plate Thin Film Photovoltaics

1.0 System Description .....	4-18
2.0 System Application, Benefits, and Impacts .....	4-19
3.0 Technology Assumptions and Issues .....	4-20
4.0 Performance and Cost .....	4-22
4.1 Evolution Overview .....	4-22
4.2 Performance and Cost Discussion .....	4-22
5.0 Land, Water, and Critical Materials Requirements .....	4-30
6.0 References .....	4-31

#### Utility-Scale Photovoltaic Concentrators

1.0 System Description .....	4-34
2.0 System Application, Benefits, and Impacts .....	4-35
3.0 Technology Assumptions and Issues .....	4-35
4.0 Performance and Cost .....	4-37
4.1 Evolution Overview .....	4-37
4.2 Performance and Cost Discussion .....	4-37
5.0 Land, Water, and Critical Materials Requirements .....	4-41
6.0 References .....	4-41

## 5 Solar Thermal

Overview of Solar Thermal Technologies .....	5-1
--	-----

### Solar Power Tower

1.0 System Description .....	5-6
2.0 System Application, Benefits, and Impacts .....	5-11
3.0 Technology Assumptions and Issues .....	5-14
4.0 Performance and Cost .....	5-16
4.1 Evolution Overview .....	5-16
4.2 Performance and Cost Discussion .....	5-18
5.0 Land, Water, and Critical Materials Requirements .....	5-21
6.0 References .....	5-22

### Solar Parabolic Trough

1.0 System Description .....	5-24
2.0 System Application, Benefits, and Impacts .....	5-31
3.0 Technology Assumptions and Issues .....	5-33
4.0 Performance and Cost .....	5-36
4.1 Evolution Overview .....	5-36
4.2 Performance and Cost Discussion .....	5-40
5.0 Land, Water, and Critical Materials Requirements .....	5-42
6.0 References .....	5-42

### Solar Dish Engine

1.0 System Description .....	5-45
2.0 System Application, Benefits, and Impacts .....	5-52
3.0 Technology Assumptions and Issues .....	5-54
4.0 Performance and Cost .....	5-56
4.1 Evolution Overview .....	5-56
4.2 Performance and Cost Discussion .....	5-56
5.0 Land, Water and Critical Materials Requirements .....	5-59
6.0 References .....	5-59

## 6 Wind

Overview of Wind Technologies .....	6-1
-------------------------------------	-----

### Advanced Horizontal Axis Wind Turbines in Wind Farms

1.0 System Description .....	6-7
2.0 System Application, Benefits, and Impacts .....	6-8
3.0 Technology Assumptions and Issues .....	6-9
4.0 Performance and Cost .....	6-11
4.1 Evolution Overview .....	6-11
4.2 Performance and Cost Discussion .....	6-17
5.0 Land, Water, and Critical Materials Requirements .....	6-30
6.0 References .....	6-31

## 7 Project Financial Evaluation

Introduction to Financial Figures of Merit .....	7-1
Financial Structures .....	7-1

Techniques for Calculating Levelized COE .....	7-2
Financial Model and Results .....	7-4
Payback Period .....	7-5

**Appendix - Energy Storage**

Overview of Energy Storage Technologies .....	A-1
---	-----

Battery Storage for Renewable Energy Systems

1.0 System Description .....	A-8
2.0 System Application, Benefits, and Impacts .....	A-10
3.0 Technology Assumptions and Issues .....	A-12
4.0 Performance and Cost .....	A-14
4.1 Evolution Overview .....	A-14
4.2 Performance and Cost Discussion .....	A-14
5.0 Land, Water, and Critical Materials Requirements .....	A-19
6.0 References .....	A-19

# FIGURES

---

## Chapter

### 1 Introduction and Overview

- Figure 1. Diversity of renewable energy resources in the United States ..... 1-3
- Figure 2. Outline for Technology Characterizations ..... 1-8

### 2 Biomass

#### Gasification-Based Biomass

- Figure 1. Biomass gasification combined cycle (BGCC) system schematic ..... 2-7
- Figure 2. Low-pressure direct gasifier ..... 2-8
- Figure 3. Indirect gasifier ..... 2-8
- Figure 4. Material and energy balance for the 1997 base case ..... 2-16

#### Direct-Fired

- Figure 1. Direct-fired biomass electricity generating system schematic ..... 2-22
- Figure 2. Material and energy balance for the 1997 base case ..... 2-29
- Figure 3. Material and energy balance for the year 2000 case ..... 2-30

#### Co-Firing

- Figure 1. Biomass co-firing retrofit schematic for a pulverized coal boiler system ..... 2-35
- Figure 2. Material and energy balance for 100 MW (Nameplate) boiler at 15% biomass co-firing ..... 2-45

### 3 Geothermal

#### Overview of Geothermal Technologies

- Figure 1. Geothermal resource quality in the United States ..... 3-3

#### Geothermal Hydrothermal

- Figure 1. Geothermal hydrothermal electric system with flashed steam power plant schematic ..... 3-6
- Figure 2. Geothermal hydrothermal electric system with binary power plant schematic ..... 3-9

#### Geothermal Hot Dry Rock

- Figure 1. Hot dry rock electric generation schematic ..... 3-29
- Figure 2. Hypothetical minimum cost curves for hydrothermal and HDR resources ..... 3-32
- Figure 3. Basin and Range geologic province ..... 3-35
- Figure 4. Results of GEOCRACK HDR reservoir simulation ..... 3-39

### 4 Photovoltaics

#### Overview of Photovoltaic Technologies

- Figure 1. Learning curve for crystalline-silicon PV ..... 4-2
- Figure 2. Direct normal insolation resource for concentrator PV (above) and global insolation resource for crystalline-silicon and thin film PV systems (below) ..... 4-3

Residential Photovoltaics	
Figure 1. Residential photovoltaic energy system schematic	4-5

Utility-Scale Flat-Plate Thin Film Photovoltaics	
Figure 1. 20 MW <sub>p</sub> (AC)/16 MW <sub>p</sub> (DC) grid-connected PV system schematic	4-18
Figure 2. Results from eight years of outdoor thin film module tests	4-25
Figure 3. Recent progress in polycrystalline thin film laboratory	4-27

Utility-Scale Photovoltaic Concentrators	
Figure 1. Grid-connected photovoltaic concentrator system schematic	4-34

## 5 Solar Thermal

Overview of Solar Thermal Technologies	
Figure 1. Solar parabolic trough	5-1
Figure 2. Solar power tower	5-2
Figure 3. Solar dish/engine system	5-2
Figure 4. Direct normal insolation resources	5-4

Solar Power Tower	
Figure 1. Molten-salt power tower schematic (Solar Two, baseline configuration)	5-6
Figure 2. Dispatchability of molten-salt power towers	5-7
Figure 3. Cool down of hot storage tank at Solar Two	5-10
Figure 4. Power tower hybridized with combined cycle plant	5-12
Figure 5. A hypothetical power profile from a hybrid plant	5-12
Figure 6. In a solar power tower, plant design can be altered to achieve different capacity factors	5-14
Figure 7. Heliostat price as a function of annual production volume	5-15

Solar Parabolic Trough	
Figure 1. Solar/Rankine parabolic trough system schematic	5-24
Figure 2. Integrated Solar Combined Cycle System	5-25
Figure 3. Luz System Three Solar Collector Assembly (LS-3 SCA)	5-28
Figure 4. On-peak capacity factors for five 30 MW SEGS plants during 1988 to 1966	5-31
Figure 5. Effect of power plant size on normalized levelized COE	5-34
Figure 6. Effect of hybridization on LEC	5-35
Figure 7. Cost reduction opportunities for parabolic trough plants	5-42

Solar Dish Engine	
Figure 1. Dish/engine system schematic. The combination of four 25 kW <sub>e</sub> units shown here is representative of a village power application	5-45
Figure 2. Schematic of a dish/engine system with stretched-membrane mirrors	5-46
Figure 3. Schematic which shows the operation of a heat-pipe solar receiver	5-48
Figure 4. Schematic showing the principle of operation of a Stirling engine	5-49
Figure 5. Schematic of a Dish/Brayton system	5-50
Figure 6. Schematic of the United Stirling 4-95 Kinematic Stirling engine	5-51

## 6 Wind

### Overview of Wind Technologies

Figure 1. U.S. wind energy resources .....	6-4
Figure 2. Potential wind energy within ten miles of transmission facilities .....	6-5

### Advanced Horizontal Axis Wind Turbines in Wind Farms

Figure 1. Horizontal axis wind turbine and windfarm system schematic .....	6-7
Figure 2. Wind energy technology evolution .....	6-14
Figure 3. Methodology for estimating annual energy production .....	6-15

## Appendix - Energy Storage

### Battery Storage for Renewable Energy Systems

Figure 1. Battery storage system schematic .....	A-8
--	-----

# TABLES

---

Chapter	Page
<b>2 Biomass</b>	
Gasification-based Biomass	
Table 1. Emissions from a high-pressure, direct gasification system .....	2-11
Table 2. Performance and costs .....	2-13
Table 3. Resource requirements .....	2-18
Direct-fired Biomass	
Table 1. Biomass power plant gaseous and particulate emissions .....	2-25
Table 2. Performance and costs .....	2-27
Table 3. Feedstock composition .....	2-26
Table 4. Resource requirements .....	2-32
Biomass Co-firing	
Table 1. Previous, existing, or planned biomass co-firing applications .....	2-39
Table 2. Performance and cost indicators .....	2-41
Table 3. Gaseous, liquid, and solid effluents .....	2-48
Table 4. Resource requirements .....	2-49
<b>3 Geothermal</b>	
Geothermal Hydrothermal	
Table 1. Environmental impacts of geothermal flashed steam plant .....	3-10
Table 2. Performance and cost indicators for a geothermal high-temperature system (“flashed-steam” technology) .....	3-13
Table 3. Performance and cost indicators for a geothermal moderate-temperature system (“binary” technology) .....	3-14
Table 4. Representative major technology improvement expected for for flashed-steam system .....	3-15
Table 5. Basic estimates of system characteristics .....	3-23
Table 6. Fixed assumption (constants, base year value) .....	3-24
Table 7. Formulas for intermediate values .....	3-24
Table 8. Final values of costs, and temporal pattern of outlays .....	3-25
Geothermal Hot Dry Rock	
Table 1. Performance and cost indicators .....	3-36
Table 2. Resource requirements .....	3-44
<b>4 Photovoltaics</b>	
Residential Photovoltaics	
Table 1. Performance and cost indicators .....	4-9
Table 2. Projections of crystalline-silicon photovoltaic module sale and prices .....	4-12
Table 3. Resource requirements .....	4-14
Table 4. Projected silicon feedstock usage and cost for various crystalline-silicon photovoltaic technologies .....	4-15

Utility-Scale Flat-Plate Thin Film PV	
Table 1. Performance and cost indicators .....	4-23
Table 2. The best thin film modules (1997) .....	4-26
Table 3. Summary of thin film direct manufacturing costs .....	4-28
Table 4. Resource requirements .....	4-30

Photovoltaic Concentrators	
Table 1. Current concentrator technology development efforts .....	4-36
Table 2. Performance and cost indicators .....	4-38
Table 3. Resource requirements .....	4-41

## 5 Solar Thermal

Overview of Solar Thermal Power Technologies	
Table 1. Characteristics of solar thermal electric power systems .....	5-3

Solar Power Tower	
Table 1. Experimental power towers .....	5-8
Table 2. Comparison of solar-energy storage systems .....	5-13
Table 3. Performance cost indicators .....	5-17
Table 4. Resource requirements .....	5-22

Solar Parabolic Trough	
Table 1. Characteristics of SEGS I through IX .....	5-27
Table 2. Solar collector characteristics .....	5-27
Table 3. Solar radiation performance adjustment .....	5-37
Table 4. Performance and cost indicators .....	5-38
Table 5. Resource requirements .....	5-42

Solar Dish Engine	
Table 1. Performance and cost indicators .....	5-57

## 6 Wind

Overview of Wind Technologies	
Table 1. Comparison of wind resource classes .....	6.3

Advanced Horizontal Axis Wind Turbines in Wind Farms	
Table 1. Performance and cost indicators .....	6-12
Table 2. Projected composite technology path .....	6-11
Table 3. Comparison of current turbine performance with 1997 TC composite turbine .....	6-18
Table 4. Windfarm loss assumptions (% of calculated gross energy) .....	6-19
Table 5. Comparison of current turbine costs with 1997 TC composite turbine estimate .....	6-20
Table 6. Performance improvement drivers .....	6-22
Table 7. Cost breakdown for 50 turbine windfarms (January 1997 \$) .....	6-24
Table 8. Major wind turbine subsystem cost drivers .....	6-26
Table 9. Project size impact on cost .....	6-28
Table 10. Resource requirements .....	6-31



**7 Project Financial Evaluation**

Techniques for Calculating Levelized COE

Table 1. Levelized Cost of Energy for GenCo Ownership ..... 7-3

Table 2. Cost of Energy for Various Ownership Cases for Biomass Gasification in  
Year 2000 ..... 7-4

**Appendix - Energy Storage**

Overview of Energy Storage Technologies

Table 1. Energy storage technology profiles ..... A-4

Battery Storage for Renewable Energy Systems

Table 1. Performance and cost indicators ..... A-15

# INTRODUCTION AND OVERVIEW

## Project Background

Since its inception in the 1970s, the U.S. Department of Energy (DOE) has operated a substantial program in the development and encouragement of renewable energy technologies. As part of its ongoing effort to document the status and potential of these technologies, DOE, along with its national laboratories and support organizations, developed the first set of Renewable Energy Technology Characterizations (TCs) in 1989. The TCs were designed to respond to DOE's need for a set of consistent cost and performance data to support the development of the biennial National Energy Policy Plans. That first set of TCs was subsequently used to support the analyses that were performed in 1991 by DOE for the National Energy Strategy. The TCs were updated in 1993, but until now had not been formally published and existed only in draft form.

The Electric Power Research Institute (EPRI), operating on behalf of its member utilities, has conducted a program in the assessment, evaluation and advancement of renewable power technologies since the mid-1970s. In that role, EPRI has been called upon by its members, and often by the energy community in general, to provide objective information on the status and outlook for renewables in prospective electric-power applications. Toward that aim, EPRI has joined with DOE to produce this set of Renewable Energy Technology Characterizations.

This joint project is one of a number of activities that DOE and EPRI are conducting under the joint DOE-EPRI Sustainable Electric Partnership entered into formally by both organizations in October 1994. It builds upon a number of activities conducted jointly by DOE and EPRI over the past two decades.

## Objectives, Approach and Scope

Purpose and Audience: In response to growing interest in renewable power technologies and the need for consistent, objective assessments of technology performance and costs, DOE and EPRI collaborated to prepare the Renewable Energy Technology Characterizations (TCs) presented in this document. Together, through this document, DOE and EPRI aim to provide for the energy community and the general public an objective picture of the status and expectations for the renewable power technologies in electric-power applications in the United States. These TCs represent a consensus between DOE and EPRI on the current status and projected development path of five renewable electricity generating technologies: biomass, geothermal, photovoltaics, solar thermal and wind. In addition, recognizing the role that storage can play in enhancing the value of some renewable power plants, a TC for storage technologies, with a strong emphasis on batteries, is included in an appendix. The TCs can serve two distinct purposes. First, they are designed to be a reference tool for energy-policy analysts and power-system planners seeking objective cost and performance data. Second, the extensive discussions of the assumptions that underlie the data provide valuable insights for R&D program planners as they strive to prioritize future R&D efforts.

Approach: Building on the best available information and experience from many years of direct involvement in the development and assessment of renewable energy technologies, experts from DOE, its national laboratories and support organizations prepared characterizations of the major renewable technologies. These were subjected to in-depth review by EPRI technical staff in renewables and selected outside reviewers, and then discussed at length in two technical workshops involving the writers and the reviewers. The characterizations were then revised, reflecting discussions at and subsequent to the workshops, resulting in this consensus document. In some cases, EPRI staff participated in preparation of overview sections.

Document Scope: The TCs do not describe specific products or hardware configurations. They describe typical system configurations at five year increments through the year 2030, based on a projected evolution of the technologies during

that timeframe. They often portray changes in expected technology configuration over time. Allowing a changing configuration ensures that, in each timeframe discussed, the TC represents the most cost-effective configuration projected to be available in that timeframe. For example, the solar thermal power tower evolves from a hybrid plant with a conventional receiver to a solar-only plant with an advanced receiver. The TCs do not attempt to pick winners among a variety of choices. In that spirit, thin film PV systems are, for example, described only in a generic way, not specifying any particular thin film technology in any given timeframe. This view of the technology future mirrors the R&D portfolio approach that DOE takes, allowing the technology itself and the marketplace to determine winners and losers.

Each TC should be thought of as a description of that technology in a particular application, typically as a grid-connected system for bulk power supply. However, some TCs do briefly describe other applications that could use substantially the same technology configuration.

These TCs differ from EPRI's Technical Assessment Guide (TAG™) in that they provide more extensive discussions of the expected technology evolution through 2030. However, the cost and performance data presented here are being used as a basis for TAG™ revisions that are currently in progress.

Similar to the TAG™, these TCs do not describe a recommended economic analysis methodology, but instead describe various approaches that could be taken to calculate levelized cost of energy or other appropriate financial figures of merit. These approaches span a range of possible ownership scenarios in a deregulated utility environment.

**Cautionary Note:** The cost and performance information presented represent the best judgments of the individuals involved in the preparation and review of this document. As these technologies enter the commercial marketplace, normal competitive forces and commercial experience may have impacts that are difficult to predict at this time. For example, there are indications that prices for some conventional power-plant components and associated engineering services are dropping as competition in power generation becomes more widespread. Based on very recent commercial experience, this trend is already reflected in the geothermal-hydrothermal flash-steam plant costs presented in this document. Similar cost impacts may be observed in other renewable power plants employing conventional thermal-generation components once the technologies become established sufficiently to attract multiple commercial suppliers. Readers are urged to use caution in applying numerical data from this document in commercial situations without consulting engineering firms actively involved in the commercial marketplace.

### **Relationship to Ongoing Renewables Programs at DOE and EPRI**

The technologies discussed in this document are considered by the renewables community, and by the managers of the DOE and EPRI renewables programs, to have good potential for contributing significantly to the U.S. electrical energy supply. Consequently, these technologies continue to receive technical and market-development support within the programs of DOE and EPRI. Of course, there is no guarantee that all of these technologies will develop and contribute as projected in this document. Rather, their individual prospects and roles will depend not only on the degree of support received, but also on the pace of progress and on societal needs and priorities. Ultimately, the marketplace, reflecting both commercial and societal forces, will decide.

### **Development-Support Assumption**

The projected progress for these technologies is based on the assumption that robust programs continue in both technology and market development. In general, these programs need both public and private sector support, with the balance shifting more toward the commercial sector as technical maturity is approached. If support for a particular technology is curtailed, then the projected progress almost certainly will not occur.

## Generic Benefits and Issues

The benefits of using renewable energy resources are many. Most of these benefits arise from their virtually inexhaustible nature. Solar and wind resources are replenished on a daily basis. Biomass can be grown through managed agricultural programs to provide continuous sources of fuel. Geothermal power is extracted from the virtually unlimited thermal energy in the earth's crust.

Renewable energy resources are broadly available across the U.S. Certain regions, however, tend to have more accessible resource of one type than another. Figure 1 illustrates this diversity. For example, in the Midwest, biomass and wind resources are excellent, as is the solar radiation needed for flat-plate photovoltaics. In the Southwest, high levels of direct normal insolation are ideally suited to solar thermal and sunlight-concentration photovoltaic technologies. Geothermal resources are concentrated in the western parts of the U.S. The availability of each of the renewable resources is explored further in the technology overviews in this document.

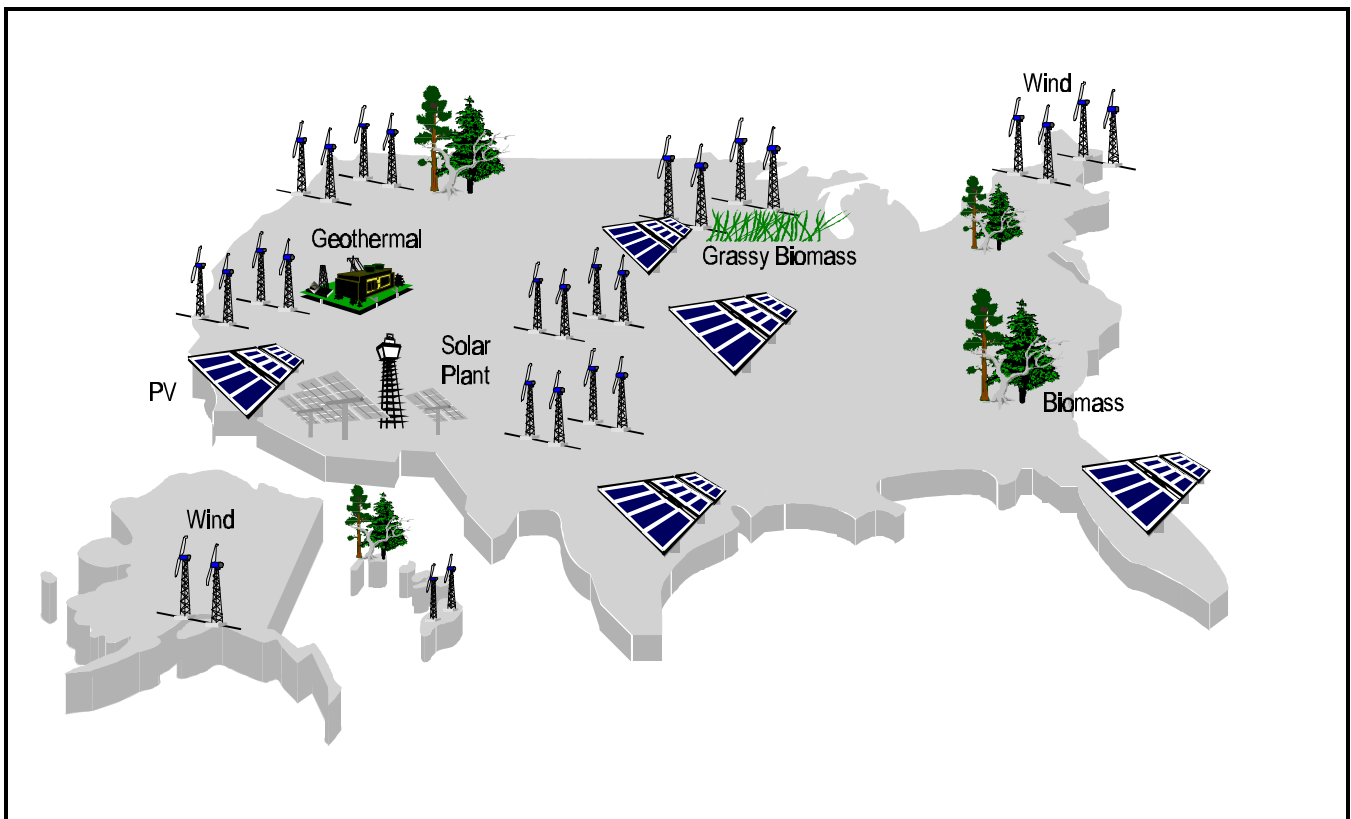

Figure 1. Diversity of renewable energy resources in the United States.

The benefits of renewable energy extend beyond abundance and diversity. As indigenous resources, they foster both local control and economic growth. An investment in renewable energy contributes to local economic security. In addition, the incorporation of renewables in a generation portfolio may reduce the risks associated with fluctuating fossil-fuel prices and supplies.

As renewable energy technologies become more cost-competitive, their true economic benefits are being realized. Since many renewable energy plants do not need to be built in large scale to achieve the lowest possible plant costs, they can be built in size increments proportionate to load growth patterns and local needs. This is often referred to as their modularity. Given their smaller size, they can also be located closer to the customer load, reducing infrastructure

costs for transmission and distribution, and helping to guarantee local power reliability and quality. Such “distributed” applications appear to have a potentially high economic value beyond just the value of the electricity generated.

Several of the renewable energy technologies, namely photovoltaics, solar-thermal and wind, produce no emissions during power generation. Biomass plants, with a properly managed fuel cycle and modern emission controls, produce zero net carbon emissions and minimal amounts of other atmospheric effluents. The situation is much the same for geothermal plants. When these technologies displace fossil fuels, they avoid emissions that would otherwise be generated. With the growing concern about climate change and carbon emissions, renewable energy technologies can be significant contributors to global efforts to reduce greenhouse-gas emissions.

The value of renewable-generated electricity is determined in part by the time of day at which the electricity is delivered to the grid and also by the probability that it will be available when needed. For example, solar output tends to follow utility summer-peak loads in many locations. Because power delivered during peak periods is more valuable to the utility system, renewable energy technologies can provide high value electricity and can be significant contributors to a reliable power supply system at critical times in those regions. Biomass, geothermal and fossil-hybrid renewable systems are fully dispatchable and compete most closely with conventional fuel-based systems. In some cases, such as the solar-thermal power tower with hot salt storage, energy-storage capability may be included economically. In these cases, the degree of dispatchability achieved depends on the amount of storage included. Intermittent systems, such as wind and solar without storage, will have value as determined primarily by the time of day and year at which electricity output is available.

Further discussions of the issue of value are contained throughout this document. It is important to realize that the proper use of financial models to determine project attractiveness requires accurate projections about the value to customers of the power from that system. In most cases, the relative merit of a particular renewable power technology is not determined solely by a levelized cost of energy.

### **Overall Perspectives on the Renewable Technologies**

While each of the characterized renewable technologies is discussed in detail in this document, the following summary presents an overview of current status and applications for each.

**Biomass:** The use of forestry and agricultural residues and wastes in direct-combustion systems for cogeneration of electricity and process heat has been a well-established practice in the forest-products industry for many years. Use of these feedstocks in utility electric power plants has also been demonstrated in several areas of the country with access to appropriate fuels, in general with acceptable technical performance and marginal economics. The marginal economics are due to the small size of many of the existing plants and the consequent high operating costs and low efficiencies. Also, fuel shortages have often driven fuel prices up and made operation too expensive. The larger-sized plants, in the 50 MW<sub>e</sub> range rather than the 10-to-25 MW<sub>e</sub> size range of many projects built in the 1980s, have economics that are acceptable when fuel costs are close to \$1/MMBtu, or when steam or heat from the direct-combustion biomass boiler is also a valued product. In addition to activity with current technology, development is proceeding on advanced direct-combustion systems.

One technology can use direct combustion of biomass fuels today without incurring the capital expense of a new boiler or a gasification/combined-cycle system. This technology is biomass co-firing, wherein biomass is co-fired, or burned together, with coal in existing power plants. Though it does not increase total power generation, this mode of operation can reduce power-plant emissions and serve as a productive use for a waste stream that requires disposal in some way. Co-firing can be carried out as a retrofit, often with very low incremental capital and O&M costs. Biomass co-firing has been successfully demonstrated in a number of utility power plants, and is a commercially available option in locations where appropriate feedstocks are available.

Biomass gasification and subsequent electricity generation in combustion-turbine or combined-cycle plants is also being pursued. This mode of operation can be more attractive than direct combustion because of (a) potentially higher thermal efficiency, (b) the ability to maintain high performance in systems over a wide range of sizes from about 5 MW to about 100 MW, and (c) increased fuel flexibility because of opportunities to reduce unwanted contaminants prior to the power generation stage. These systems are in the development and demonstration phase. The key issue requiring successful resolution is sufficient cleanup of the biogas so that turbine damage is avoided. The gas must be cleaned of alkalis to gas-turbine-entrance standards, and this cleanup must take place in an environment that is prone to tar formation.

Geothermal: Commercial electricity from geothermal steam reservoirs has been a reality for over 30 years in California and Italy. However, steam reservoirs are rare and have already been exploited, at least in the developed countries. Of greater potential in both developed and developing countries are geothermal-hot-water, or liquid-dominated-hydrothermal, resources. A number of hydrothermal plants, perhaps 30 to 40, both developmental and commercial, have been built and are in operation. Some use conventional steam-separation and steam-cycle power-plant equipment, while others employ a binary cycle that takes advantage of working fluids with lower vaporization temperatures than water. Commercial attractiveness depends largely on the quality of the hydrothermal resource: temperature of the hot water, permeability of the rock formation, chemistry of the hot water, and necessary drilling depth. To ascertain this quality, wells need to be drilled. Since the outcome is not assured prior to drilling, locating suitable resources presents a major commercial risk.

Another geothermal-power approach is in the research stage. This involves drilling deep holes (one-to-five kilometers) to reach hot dry rock that is close to locations where magma or other hot intrusions from the molten mantle of the Earth come unusually close to the surface. In this context, "dry" rock implies that no natural water source is associated with the hot rock, unlike the situation in the hydrothermal case. Water from a surface source would be injected, heated, used in a steam- or binary-power cycle, and then re-injected for recycling. If successful, this approach could make available a huge resource relative to present geothermal resources. However, technical uncertainties and risks are very high, so the commercial potential of this approach cannot be estimated accurately today.

Photovoltaics: Photovoltaic power systems convert sunlight directly into electricity through a solid-state-electronic process that involves no moving parts, no fluids, no noise and no emissions of any kind. These features are attractive from operating, maintenance and environmental standpoints, and have positioned photovoltaics to be the preferred power technology for many remote applications both in space and on the ground. Relative to conventional grid power, photovoltaic electricity is some five-to-ten-times more expensive. Hence, it is currently used in locations or applications where utility distribution lines are not readily available. Newer, potentially lower-cost photovoltaic technology is emerging from ongoing industry-government research and development programs, and its use in commercial and demonstration applications is beginning.

Although increasing use could occur more rapidly in some developing countries, grid-competitive photovoltaic electricity is probably ten-to-twenty years off in the developed world. However, interest is growing in a new mode of photovoltaic deployment, called building-integrated, where the photovoltaic cells or modules become integral to structural, protective or cosmetic elements of a building such as roofs and facades. In these applications, the high cost of the photovoltaic components is partially masked by the cost of the building elements, and the decision to employ photovoltaics is made on the basis of such factors as aesthetics and social conscience rather than cost of electricity alone. Many believe that this commercial entry strategy will ultimately succeed in reducing photovoltaic costs through production experience to the point where they can approach costs of grid power. Several governments and many communities in the developed world are incentivizing these applications based on this belief. Because of the growing prominence of building-integrated and other on-site applications of photovoltaics, a section on residential rooftop photovoltaic systems is included in this document.

Another approach to power plants employing photovoltaics uses concentrated sunlight in conjunction with unusually high-performance photovoltaic cells. While attractive technical performance has been demonstrated in some instances, an early market for these systems has not materialized. Unlike flat-plate photovoltaic systems that have established themselves in remote power applications, the potentially high-performance concentrator systems have not yet established a track record in the field. This, coupled with the need to build relatively large systems (at least several tens of kW) to realize their cost advantage and the added complexity associated with required sunlight tracking, has seriously hampered market entry up to now.

Solar Thermal: Solar thermal power systems use concentrated sunlight to heat a working fluid that generates electricity in a thermodynamic cycle. Three general approaches have received development attention. The first, called the central-receiver or power-tower configuration, employs a field of mirrors that track the sun and reflect sunlight to a central receiver atop a tower. The working fluid is circulated through and heated in the receiver, and is then used to drive a conventional turbine. The fluid and its thermal energy can be stored to decouple the collection of the solar energy and the generation of electricity, enabling this power plant to be dispatched much like conventional thermal power plants. This is an attractive feature to electric utilities and power system managers. Several experimental and demonstration power-tower systems have been built; and one, employing thermal storage, is currently under test and evaluation in California. As yet, the commercial prospects for this approach cannot be accurately projected.

Another approach employs parabolic dishes, either as single units or in fields, that track the sun. A receiver is placed at the focal point of the dish to collect the concentrated solar energy and heat the system's working fluid. That fluid then drives an engine attached to the receiver. Dish systems also have potential for hybridization, although more developmental work is required to realize this potential. In contrast to the other two approaches, which are targeted at plants in the 30 MW and higher range, and which use a single turbine-generator fed by all of the solar collectors, each dish-receiver-engine unit is a self-contained electricity-generating system. Typically, these are sized at about 10 to 30 kW. Hence, a larger power plant is obtained by employing a number of these units in concert. With some interruptions due to changing market conditions, dish systems using Stirling engines have been deployed, with both public and private support, for experimental and demonstration purposes since the early 1980s. Current development and demonstration activities are aimed at key technical and economic issues that need to be resolved before commercial prospects can be clarified. Stirling-engine development for prospective vehicular applications is also under way. If successful, transportation sector market penetration would substantially improve the commercial outlook for solar dish-Stirling systems.

The third approach employs a field of sunlight-tracking parabolic troughs that focus sunlight onto the linear axis of the trough. A glass or metal linear receiver is placed along this axis, and a working fluid is circulated through and heated in this receiver. The fluid from a field of troughs passes through a central location where thermal energy is extracted via a heat exchanger and then used to drive a conventional turbine. This configuration lends itself well to hybrid operation with fossil fuel combustion as a supplemental source of thermal energy.

In the early 1980s, federal and California-state financial incentives were established to encourage the commercial deployment and use of emerging renewables. Two technologies were in a position to benefit from these incentives: solar thermal troughs and wind turbines. Trough systems were deployed on a commercial basis in the 1980s and early 1990s, and continue to operate today. In addition to the government-tax-credit incentives, these plants were partially supported by above-market energy payments that are no longer available. Hence trough systems have not been offered commercially since 1991. Should conventional energy costs rise to the above-market support levels of the late 1980s (when significant increases in oil prices were being projected), or should significant incentives for renewable energy arise in the near future, trough technology would be available to play an important role in areas with good sunlight. In addition, efforts are underway to revive this technology for use in developing countries that have urgent needs for new electric power sources, such as India and Mexico.

Although the solar-thermal trough (and wind) systems fielded in the early 1980s experienced considerable technical difficulties, the overall result of the deployments of the 1980s and the associated experience and technical development was that both trough systems and wind systems (see wind discussion below) had achieved technical and commercial credibility by the early 1990s. Energy costs from these systems were approaching the competitive range for grid power. Trough-energy costs were somewhat higher than wind-energy costs; but, owing to hybridization with natural gas, the trough plants were dispatchable. Hence their energy had higher value in some instances. Wind energy, in contrast, was available only when the wind blew.

Wind: As mentioned above, wind power systems progressed substantially as a result of the 1980s government incentives, with a steady trend of cost reductions throughout the 1980s. Since 1990, the cost of energy from the wind has continued to decline, due to continued deployment and to public-private development programs in the U.S. and, to an even greater extent, in Europe. Wind power is now on the verge of becoming a commercially established and competitive grid-power technology. Although expansion of the U.S. wind market has been slowed since the onset of electric-sector restructuring in 1995, the wind markets in Europe and elsewhere in the world have continued to grow, led by firms in Denmark and Germany. The growth of wind in Europe has been fueled, in part, by aggressive goals for renewable power deployment in response to strong public and political support for clean energy and growing concern over global climate change. And there are signs that the pace of wind deployment in the U.S. is again on the rise.

With the exception of the Southeast, most regions of the U.S. have commercially attractive winds. In addition to wind resource quality, other issues that need to be considered, as with most commercial power plants, are transmission requirements and potential environmental impacts. Most U.S. wind facilities installed to date are wind farms with many turbines interconnected to the utility transmission grid through a dedicated substation. There is growing interest in distributed wind facilities, with a small number of turbines connected directly to the utility distribution system without a substation. Such installations account for more than half of the over 4,000 MW of wind in Europe, but the U.S. to date has little experience with this mode. Hence this document focuses on central-station wind applications.

The great majority of wind power experience has been obtained with the traditional wind turbine configuration, in which the rotor revolves about a horizontal axis. In addition, several development programs of the past twenty years have focused on turbines with rotors that turn about a vertical axis (sometimes called “egg-beater” turbines). Although the case cannot be considered completely closed, the weight of experience indicates strongly that the vertical axis machines will not show a performance or commercial advantage relative to the horizontal axis machines. Hence development of the vertical axis units has all but halted, and this document focuses entirely on horizontal axis turbines.

Energy Storage: Recent advances in batteries and other storage technologies have resulted in systems that can play a flexible, multi-functional role in the electricity supply network to manage power resources effectively. The current electricity market offers a number of opportunities for energy storage technologies in which storage of a few seconds to a few hours of electricity is valuable. These systems can be located near the generator, transmission line, distribution substation, or the consumer. Improved, low-maintenance, spill-proof, relatively compact lead-acid batteries are commercially available today.



Energy storage systems are used beneficially today in a variety of applications. Examples include mitigation of power-quality problems and provision of back-up power for commercial/industrial customers, utility substations, and transmission-line stability. In addition, energy storage can play an important role in enabling the increased utilization of intermittent renewable energy sources such as wind and photovoltaics. In grid-connected applications, the storage system can be charged from the renewable source or from the utility grid, whichever is economically preferred.

## Document Overview

The five main chapters of this document correspond to five categories of renewable electricity-generating technologies -- biomass, geothermal, photovoltaics, solar thermal, and wind. Each of these five chapters has an Overview that discusses key development and deployment issues for that technology category. Each chapter has one or more Technology Characterizations (TCs); e.g., there are TCs for hydrothermal and hot dry rock systems within the geothermal technology category. Each TC was prepared in the format outlined in Figure 2. In addition, energy storage is characterized in an appendix that follows the same format.

Chapter 7 provides a discussion of financial analysis techniques. The chapter also provides estimates of levelized cost of energy using these techniques.

Technology Characterization Outline	
<b>1.0 System Description:</b>	This section begins with a detailed graphic depicting key components and subsystems. A system boundary is shown, drawn around any required substation or other required grid interface equipment. The section includes a detailed discussion of the major system features, and how the system depicted in the schematic operates.
<b>2.0 System Application, Benefits, and Impacts:</b>	This section contains a description of the applications for which the given system is designed. The motivation for developing the system is given, as is a description of the energy service provided by the system. Also delineated are the potential economic and environmental benefits and impacts.
<b>3.0 Technology Assumptions and Issues:</b>	This section includes an explanation of current technological status and the anticipated progression of the technology through the year 2030. It also includes assumptions concerning the system being characterized, including location, commercial readiness, resource assumptions, and the energy service that the system provides. Perspectives on R&D efforts needed to ensure future progress are also presented.
<b>4.0 Performance and Cost:</b>	This section contains the primary data table describing current (1997) and projected future (through 2030) technology cost and performance.
<b>4.1 Evolution Overview:</b>	This subsection provides a short description of how the baseline system's configuration, size and key components evolve over the period.
<b>4.2 Performance and Cost Discussion:</b>	This section provides a detailed discussion to explain and justify the projections made for the technical performance and cost indicators in the table found in Section 4.0. Assumptions, methods, rationale, and references are also provided.
<b>5.0 Land, Water, and Materials Requirements:</b>	This section contains a table and short discussion regarding the land and water requirements for the technology. It also includes a listing of any materials considered unique to the technology (e.g., cell raw materials, catalysts).
<b>6.0 References:</b>	A complete list of the literature cited is included.

Figure 2. Outline for Technology Characterizations

## OVERVIEW OF BIOMASS TECHNOLOGIES

### Situation Analysis

Biopower (biomass-to-electricity power generation) is a proven electricity-generating option in the United States. With about 10 GW of installed capacity, biopower is the single largest source of non-hydro renewable electricity. This installed capacity consists of about 7 GW derived from forest-product-industry and agricultural-industry residues, about 2.5 GW of municipal solid waste (MSW) generating capacity, and 0.5 GW of other capacity such as landfill gas-based production. The electricity production from biomass is being used, and is expected to continue to be used, as base load power in the existing electric-power system.

In the U.S., biopower experienced dramatic growth after the Public Utilities Regulatory Policy Act (PURPA) of 1978 guaranteed small electricity producers (less than 80 MW) that utilities would purchase their surplus electricity at a price equal to the utilities' avoided-cost of producing electricity. From less than 200 MW in 1979, biopower capacity grew to 6 GW in 1989 and to today's capacity of 7 GW. In 1989 alone, 1.84 GW of capacity was added. The present low buyback rates from utilities, combined with uncertainties about industry restructuring, have slowed industry growth and led to the closure of a number of facilities in recent years.

The 7 GW of traditional biomass capacity represents about 1% of total electricity generating capacity and about 8% of all non-utility generating capacity. More than 500 facilities around the country are currently using wood or wood waste to generate electricity. Fewer than 20 facilities are owned and operated by investor-owned or publicly-owned electric utilities. The majority of the capacity is produced in Combined Heat and Power (CHP) facilities in the industrial sector, primarily in pulp and paper mills and paperboard manufacturers. Some of these CHP facilities have buyback agreements with local utilities to purchase net excess generation. Additionally, a moderate percentage of biomass power facilities are owned and operated by non-utility generators, such as independent power producers, that have power purchase agreements with local utilities. The number of such facilities is decreasing somewhat as utilities buy back existing contracts. To generate electricity, the stand-alone power production facilities largely use non-captive residues, including wood waste purchased from forest products industries and urban wood waste streams, used wood pallets, some waste wood from construction and demolition, and some agricultural residues from pruning, harvesting, and processing. In most instances, the generation of biomass power by these facilities also reduces local and regional waste streams.

All of today's capacity is based on mature, direct-combustion boiler/steam turbine technology. The average size of existing biopower plants is 20 MW (the largest approaches 75 MW) and the average biomass-to-electricity efficiency of the industry is 20%. These small plant sizes lead to higher capital cost per kilowatt of installed capacity and to high operating costs as fewer kilowatt-hours are produced per employee. These factors, combined with low efficiencies which increase sensitivity to fluctuations in feedstock price, have led to electricity costs in the 8-12¢/kWh range.

The next generation of stand-alone biopower production will substantially reduce the high costs and efficiency disadvantages of today's industry. The industry is expected to dramatically improve process efficiency through the use of co-firing of biomass in existing coal-fired power stations, through the introduction of high-efficiency gasification - combined-cycle systems, and through efficiency improvements in direct-combustion systems made possible by the addition of fuel drying and higher performance steam cycles at larger scales of operation. Technologies presently at the research and development stage, such as Whole Tree Energy™ integrated gasification fuel cell systems, and modular systems, are expected to be competitive in the future.

## OVERVIEW OF BIOMASS TECHNOLOGIES

### Technology Alternatives

The nearest term low-cost option for the use of biomass is co-firing with coal in existing boilers. Co-firing refers to the practice of introducing biomass as a supplementary energy source in high efficiency boilers. Co-firing has been practiced, tested, or evaluated for a variety of boiler technologies, including pulverized coal boilers of both wall-fired and tangentially-fired designs, coal-fired cyclone boilers, fluidized-bed boilers, and spreader stokers. The current coal-fired power generating system presents an opportunity for carbon mitigation by substituting biomass-based renewable carbon for fossil carbon. Extensive demonstrations and trials have shown that effective substitutions of biomass energy can be made in the range of 10-15% of the total energy input with little more than burner and feed intake system modifications to existing stations. One preliminary test reached 40% of the energy from biomass. Within the current 310 GW of installed coal capacity, plant sizes range from 100 MW to 1.3 GW. Therefore, the biomass potential in a single boiler ranges from 15 MW to 130 MW. Preparation of biomass for co-firing involves well known and commercial technologies. After “tuning” the boiler’s combustion output, there is very little loss in total efficiency. Since biomass in general has much less sulfur than coal, there is an SO<sub>2</sub> benefit, and early test results suggest that there is also a NO<sub>x</sub> reduction potential of up to 30% with woody biomass co-fired in the 10-15% range. Investment levels are very site-specific and are affected by the available space for yarding and storing biomass, installation of size reduction and drying facilities, and the nature of the boiler burner modifications. Investments are expected to be \$100-700/kW of biomass capacity, with a median in the \$180-200/kW range. Note that these values are per kW of biomass, so, at 10% co-fire, \$100/kW adds \$10/kW to the total, coal plus biomass, capacity costs.

Another potentially attractive biopower option is gasification. Gasification for power production involves the devolatilization and conversion of biomass in an atmosphere of steam or air to produce a medium-or low-calorific gas. This “biogas” is then used as fuel in a combined cycle power generation plant that includes a gas turbine topping cycle and a steam turbine bottoming cycle. A large number of variables influence gasifier design, including gasification medium (oxygen or no oxygen), gasifier operating pressure, and gasifier type. Advanced biomass power systems based on gasification benefit from the substantial investments made in coal-based gasification combined cycle (GCC) systems in the areas of hot gas particulate removal and synthesis gas combustion. They also leverage investments made in the Clean Coal Technology Program (commercial demonstration cleanup and utilization technologies) and in those made as part of DOE’s Advanced Turbine Systems (ATS) Program. Biomass gasification systems will also be appropriate to provide fuel to fuel cell and hybrid fuel-cell/gas-turbine systems, particularly in developing or rural areas without cheap fossil fuels or having a problematic transmission infrastructure. The first generation of biomass GCC systems would have efficiencies nearly double that of direct-combustion systems (e.g., 37% vs. 20%). In cogeneration applications, total plant efficiencies could exceed 80%. This technology is very near to commercial availability with one small (9MW equivalent) plant operating in Sweden. Costs of a first-of-a-kind biomass GCC plant are estimated to be in the \$1,800-2,000/kW range, with the cost dropping rapidly to the \$1,400/kW range for a mature plant in the 2010 time frame.

Direct-fired combustion technologies are another option, especially with retrofits of existing facilities to improve process efficiency. Direct combustion involves the oxidation of biomass with excess air, producing hot flue gases which produce steam in the heat exchange sections of boilers. The steam is used to produce electricity in a Rankine cycle. In an electricity-only process, all of the steam is condensed in the turbine cycle while, in CHP operation, a portion of the steam is extracted to provide process heat. Today’s biomass-fired steam cycle plants typically use single pass steam turbines. In the past decade, however, efficiency and design features found previously in large-scale steam turbine generators have been transferred to smaller capacity units. These designs include multi-pressure, reheat and regenerative steam turbine cycles, as well as supercritical steam turbines. The two common boiler designs used for steam generation with biomass are stationary and traveling-grate combustors (stokers) and atmospheric fluid-bed combustors. The addition of drying processes and incorporation of higher performance steam cycles is expected to raise the efficiency of direct-combustion systems by about 10% over today’s best direct-combustion systems, and to lower the capital investment from the present \$2,000/kW to about \$1,300/kW or below.

## OVERVIEW OF BIOMASS TECHNOLOGIES

The three technologies discussed in the detailed technology characterizations are all at either the commercial or commercial-prototype stage. There are additional technologies that are at the conceptual or research and development stage and thus do not warrant development of a comparable technology characterization at this time. However, these options are potentially attractive from a performance and cost perspective and therefore do merit discussion. These technologies include the Whole Tree Energy™ process, biomass gasification fuel cell processes, and small modular systems such as biomass gasification Stirling engines.

The Whole Tree Energy™ process is under development by Energy Performance Systems, with the support of EPRI and DOE, for application to large-scale energy crop production and power generation facilities, with generating capacities above 100 MW. To improve thermal efficiency, a 16.64 MPa/538 °C process is being developed. Whole trees are to be harvested by cutting the trees at the base, then transported by truck to the power plant, stacked in a drying building for about 30 days, dried by air heated in the second stage of the air heater downstream of the boiler, and burned under starved-air conditions in a deep-bed combustor at the bottom of the furnace. A portion of the moisture in the flue gas will be condensed in the second stage of the air heater and collected along with the fly ash in a wet particulate scrubber. The remainder of the plant is similar to a stoker plant. Elements of the process have been tested, but the system has not been tested on an integrated basis.

Gasification fuel cell systems hold the promise of high efficiency and low cost at a variety of scales. The benefits may be particularly pronounced at scales previously associated with high cost and low efficiency (i.e., from < 1 MW to 20 MW). Fuel cell-based power systems are likely to be particularly suitable as part of distributed power generation strategies in the U.S. and abroad. Extensive development of molten carbonate fuel cell (MCFC) technology has been conducted under DOE and EPRI's sponsorship, largely with natural gas as a test fuel. Several demonstration projects are underway in the U.S. for long-term testing of these cells. A limited amount of testing was also done with MCFC technology on synthesis gas from a coal gasifier at Dow Energy Systems' (DESTEC) facility in Plaquemine, LA. The results from this test were quite promising.

No fuel cell testing has been done to-date with biomass-derived gases despite the several advantages that biomass has over coal in this application. Biomass' primary advantage is its very low sulfur content. Sulfur-containing species are a major concern in fossil fuel-based fuel cell systems since fuel cells are very sensitive to this contaminant. An additional biomass advantage is its high reactivity. This allows biomass gasifiers to operate at lower temperatures and pressures while maintaining throughput levels comparable to their fossil-fueled counterparts. These relatively mild operating conditions and a high throughput should permit economic construction of gasifiers of a relatively small scale that are compatible with planned fuel cell system sizes. Additionally, the operating temperature and pressure of MCFC units may allow a high degree of thermal integration over the entire gasifier/fuel cell system. Despite these obvious system advantages, it is still necessary for actual test data to be obtained and market assessments performed to stimulate commercial development and deployment of fuel cell systems.

The Stirling engine is designed to use any heat source, and any convenient working gas, to generate energy, in this case electricity. The basic components of the Stirling engine include a compression space and an expansion space, with a heater, regenerator, and cooler in between. Heat is supplied to the working gas at a higher temperature by the heater and is rejected at a lower temperature in the cooler. The regenerator provides a means for storing heat deposited by the hot gas in one stage of the cycle, and releasing it to heat the cool gas in a subsequent stage. Stirling engine systems using biomass are ideal for remote applications, stand-alone or cogeneration applications, or as backup power systems. Since the Stirling engine is an external combustion system, it requires less fuel-gas cleanup than gas turbines. A feasibility test of biomass gasification Stirling engine generation has been performed by Stirling Thermal Motors using a 25 kW engine connected to a small Chiptec updraft gasifier. While the results were encouraging, further demonstration of the concept is required.

## OVERVIEW OF BIOMASS TECHNOLOGIES

### Markets

Biopower systems encompass the entire cycle -- growing and harvesting the resource, converting and delivering electricity, and recycling carbon dioxide during growth of additional biomass. Biomass feedstocks can be of many types from diverse sources. This diversity creates technical and economic challenges for biopower plant operators because each feedstock has different physical and thermochemical characteristics and delivered costs. Increased feedstock flexibility and smaller scales relative to fossil-fuel power plants present opportunities for biopower market penetration. Feedstock type and availability, proximity to users or transmission stations, and markets for potential byproducts will influence which biomass conversion technology is selected and its scale of operation. A number of competing biopower technologies, such as those discussed previously, will likely be available. These will provide a variety of advantages for the U. S. economy, from creating jobs in rural areas to increasing manufacturing jobs.

The near-term domestic opportunity for GCC technology is in the forest products industry. A majority of its power boilers will reach the end of their useful life in the next 10-15 years. This industry is already familiar with use of its low-cost residues ("hog" fuel and even a waste product called "black liquor") for generation of electricity and heat for its processing needs. The higher efficiency of gasification-based systems would bolster this self-generation (offsetting the need for increased electricity purchases from the grid) and perhaps allow sales of electricity to the grid. The industry is also investigating the use of black liquor gasification in combined cycles to replace the aging fleet of kraft recovery boilers.

An even more near-term and low-cost option for the use of biomass is co-firing with coal in existing boilers. Co-firing biomass with coal has the potential to produce 10 to 20 GW in the next twenty years. Though the current substitution rate is negligible, a rapid expansion is possible using wood residues (urban wood, pallets, secondary manufacturing products) and dedicated feedstock supply systems such as willow, poplar and switchgrass.

### Resource Issues

Nationally, there appears to be a generous fuel supply. However, the lack of an infrastructure to obtain fuels and the current lack of demonstrated technology to combust or gasify new fuels currently prevents utilization of much of this supply. According to researchers at Princeton University, of the total U.S. biomass residues available, half could be economically used as fuel. They estimate that of the 5 exajoules (4.75 quads) of recoverable residues per year, one third are made up of agricultural wastes and two thirds composed of forestry products industry residues (60% of which are mill residues). Urban wood and paper waste, recoverable in the amount of 0.56 EJ per year, will also be an important source. Pre-consumer biomass waste is also of increasing interest to urban utilities seeking fuels for co-firing, and such use also provides a useful service to the waste producer.

In the Southeast, biomass resources are plentiful, with 91.8 Tg of biomass fuel produced annually according to a study done in the mid-1980s by the Southeast Regional Biomass Energy Program. This translates to an estimated potential of 2.3 EJ of annual energy. North Carolina and Virginia are the biggest wood fuel producers (10.4 and 10.1 Tg, respectively). These residues come primarily from logging applications, culls and surplus growth, and are in the form of whole tree chips. In the western U.S., California is another major user of biomass energy. The California biomass market grew from about 0.45 Tg in 1980 to about 5 Tg in the early 1990s. Feedstocks include mill residues, in-forest residues, agricultural wastes and urban wood waste.

Worldwide, biomass ranks fourth as an energy resource, providing approximately 14% of the world's energy needs. In developing countries, biomass accounts for approximately 35% of the energy used, and in the rural areas of these nations, biomass is often the only accessible and affordable source of energy [1,2]. There is much optimism that biomass will continue to play a significant, and probably increasing, role in the world's future energy mix. The basis

## OVERVIEW OF BIOMASS TECHNOLOGIES

for this optimism stems from: (1) the photosynthetic productivity of biomass (conservatively an order of magnitude greater than the world's total energy consumption); (2) the fact that bioenergy can be produced and used in a clean and sustainable manner; and (3) continuing advancements in biomass conversion technologies along several fronts. Increased bioenergy use, especially in industrialized countries, will depend on greater exploitation of existing biomass stocks (particularly residues) and the development of dedicated feedstock supply systems.

Because the future supply of biomass fuels and their prices can be volatile, many believe that the best way to ensure a future fuel supply is through the development of dedicated feedstocks. Large-scale dedicated feedstock supply systems designed solely for use in biomass power plants do not exist in the U.S. today on a commercial basis. The DOE Biomass Power Program (BPP) recognizes this fact, and a major part of the commercial demonstration program directly addresses dedicated feedstock supply issues. The 'Biomass Power for Rural Development' projects in New York (willow), Iowa (switchgrass), and Minnesota (alfalfa) are developing the commercial feedstock infrastructure for dedicated feedstocks. The Minnesota Valley alfalfa producers project will involve the production of 700,000 tons/year of alfalfa on 101,000 hectares (250,000 acres) of land. Unused agricultural lands in the U.S. (31.6 million ha in 1988) are primary candidates for tree plantations or herbaceous energy crops. About 4% of the land within an 80 km radius could supply a 100 MW plant operating at 70% capacity. Although, there are requirements for water, soil type and climate that will restrict certain species to certain areas, an assured regional fuel supply can reduce variability in prices.

Oak Ridge National Laboratory also has an extensive feedstock development and resource assessment program that is closely integrated with the DOE BPP. ORNL is responsible for development and testing of the switchgrass and hybrid poplar species that are receiving intense interest by not only the commercial power project developers, but also the forest products industry.

Although not directly applicable, there are numerous examples in the agriculture and pulp and paper industries that serve to illustrate the feasible size of sustainable commercial biomass operations. There are over fifty pulp and paper mills in the U.S. that produce more than 500,000 tons/year of product [3]. The feed into such plants is at least one third higher than the product output, with the additional increment being used for internal power and heat generation. The sugarcane industry also routinely harvests, transports, and processes large quantities of biomass. In the U.S. alone, more than a dozen sugar mills each process more than 1.3 million tons of cane per year, including four plants in Florida that process more than 2.25 million tons/year [4]. Sweden and the other Scandinavian countries have long been leaders in the biomass energy arena. Currently, Sweden has over 16,500 hectares of farmland planted in willow for energy use. The market for woody biomass for energy in Sweden has experienced strong growth, with a steady increase equivalent to 3-4 TWh extra each year for the last five years. This equals one nuclear power station in aggregate every two years. Additionally, Denmark annually produces roughly 7 million tons of wheat straw that cannot, by law, be burned in-field. This straw is increasingly being used for energy production. Thus, there is ample evidence that agricultural, harvest, transport, and management technologies exist to support power plants of the size contemplated.

## OVERVIEW OF BIOMASS TECHNOLOGIES

### Environmental Issues

Two primary issues that could create a tremendous opportunity for biomass are: (1) global climate change and (2) the implementation of Phase II of Title IV of the Clean Air Act Amendments of 1990 (CAAA). Biomass offers the benefit of reducing NO<sub>x</sub>, SO<sub>2</sub>, and CO<sub>2</sub> emissions. The environmental benefits of biomass technologies are among its greatest assets. The first issue, global climate change, is gaining greater salience in the scientific community. There now appears to be a consensus among the world's leading environmental scientists and informed individuals in the energy and environmental communities that there is a discernable human influence on the climate, and that there is a link between the concentration of carbon dioxide (i.e., greenhouse gases) and the increase in global temperatures. The recognition of this link is what led to the signing of the Global Climate Change treaty. Co-firing biomass with fossil fuels and the use of integrated biomass-gasification combined cycle systems can be an effective strategy for electric utilities to reduce their emissions of greenhouse gases.

The second issue, the arrival of Phase II emission requirements, could also create a number of new opportunities for biomass to be used more widely in industrial facilities and electric power generating units. The key determinant will be whether biomass fuels offer the least expensive option for a company when compared to the installation of pollution control equipment or switching to a "cleaner" fossil fuel.

The second, and more restrictive, phase of the CAAA goes into effect in 2000. CAAA is designed to reduce emissions of sulfur dioxide (SO<sub>2</sub>) and nitrogen oxides (NO<sub>x</sub>), that make up acid rain, and are primarily emitted by fossil-fuel powered generating stations. The first phase of CAAA affects the largest emitters of SO<sub>2</sub> and NO<sub>x</sub>, while the second phase will place tighter restrictions on emissions not only from these facilities, but also from almost all fossil-fuel powered electric generators of 25 MW or greater, utilities and non-utilities alike. The impact of Phase II will be tempered by the fact that most of the utilities that had to comply with Phase I chose to over comply, thereby creating a surplus of allowances for Phase II use. The planned strategies for compliance by utilities suggest that fuel switching will be the compliance of choice. Fuel switching will be primarily to low sulfur coal. Other strategies include co-firing with natural gas, purchasing of allowances, installing scrubbers, repowering of existing capacity, and retirement of existing capacity. An opportunity exists for biomass, especially if credit is given for simultaneous reduction in greenhouse gases.

Use of biomass crops also has the potential to mitigate water pollution. Since many dedicated crops under consideration are perennial, soil disturbance, and thus erosion can be substantially reduced. The need for agricultural chemicals is often lower for dedicated energy crops as well leading to lower stream and river pollution by agricultural runoff.

### References

1. McGowan, F., "Controlling the Greenhouse Effect--the Role of Renewables," *Energy Policy*, March 1991, p. 111-118.
2. Hall, D.O., F. Rosillo-Calle, and P. de Groot, "Biomass Energy--Lessons from Case Studies in Developing Countries," *Energy Policy*, January 1992, p. 62-73.
3. *Pulp and Paper 1996 North American Fact Book*, Miller Freeman, San Francisco, CA, 1995. ISBN10-87930-4219.
4. *Gilmore Sugar Manual, 1994/95*, Sugar Publications, Fargo, ND, 1994.

# GASIFICATION-BASED BIOMASS

## 1.0 System Description

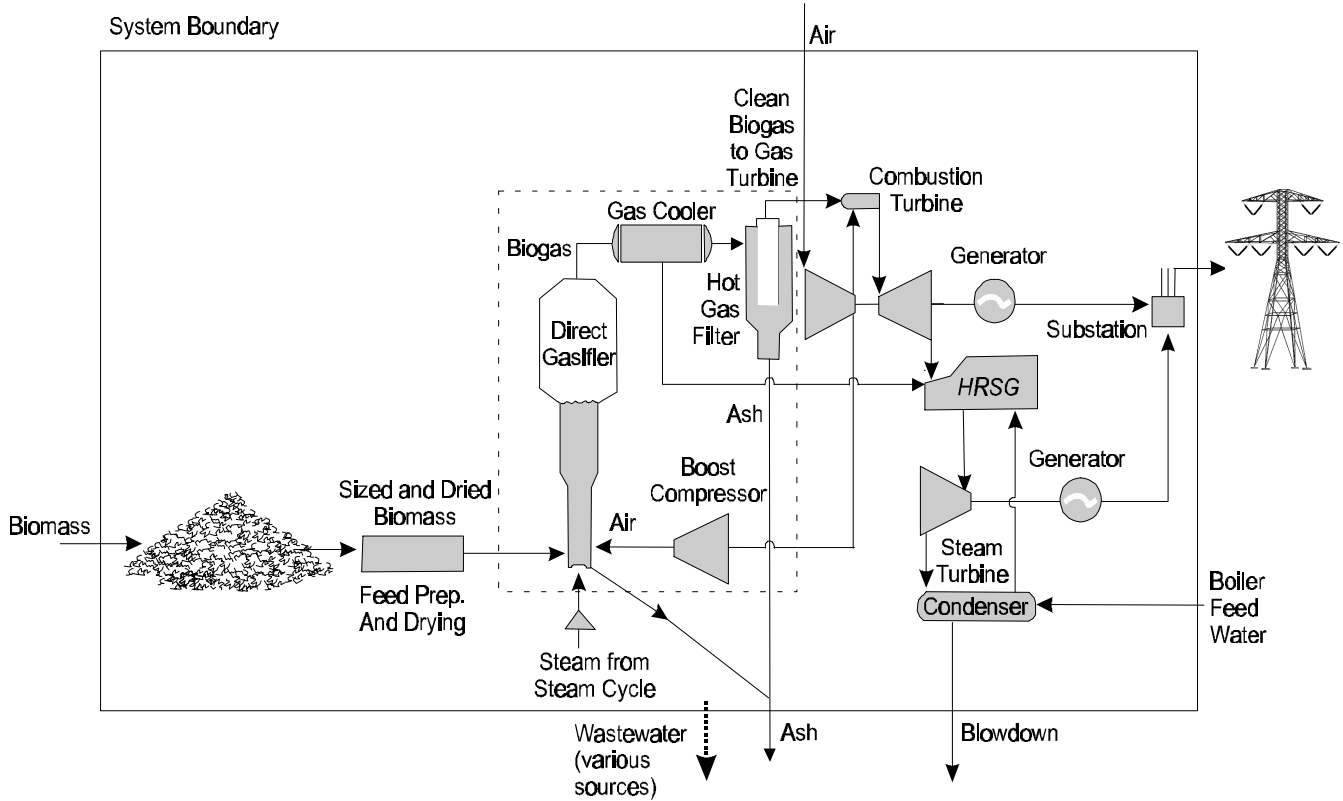

Figure 1. Biomass gasification combined cycle (BGCC) system schematic.

The conversion of biomass to a low- or medium-heating-value gaseous fuel (biomass gasification) generally involves two processes. The first process, pyrolysis, releases the volatile components of the fuel at temperatures below 600°C (1,112°F) via a set of complex reactions. Included in these volatile vapors are hydrocarbon gases, hydrogen, carbon monoxide, carbon dioxide, tars, and water vapor. Because biomass fuels tend to have more volatile components (70-86% on a dry basis) than coal (30%), pyrolysis plays a proportionally larger role in biomass gasification than in coal gasification. The by-products of pyrolysis that are not vaporized are referred to as char and consist mainly of fixed carbon and ash. In the second gasification process, char conversion, the carbon remaining after pyrolysis undergoes the classic gasification reaction (i.e. steam + carbon) and/or combustion (carbon + oxygen). It is this latter combustion reaction that provides the heat energy required to drive the pyrolysis and char gasification reactions. Due to its high reactivity (as compared to coal and other solid fuels), all of the biomass feed, including char, is normally converted to gasification products in a single pass through a gasifier system.

This report characterizes a biomass gasification combined cycle (BGCC) system as depicted in Figure 1. A high pressure, direct gasifier shown inside the dashed line within Figure 1 is considered here. Several other gasifier options are possible, specifically low pressure direct gasifiers (Figure 2) and indirect gasifiers (Figure 3). Depending on the type of gasifier used, the above reactions can take place in a single reactor vessel or be separated into different vessels. In the case of direct gasifiers, pyrolysis, gasification, and combustion take place in one vessel, while in indirect gasifiers, pyrolysis and gasification occur in one vessel, and combustion in a separate vessel. In direct gasification, air



## GASIFICATION-BASED BIOMASS

and sometimes steam are introduced directly to the single gasifier vessel (Figures 1 and 2). In indirect gasification, an inert heat transfer medium such as sand carries heat generated in the combustor to the gasifier to drive the pyrolysis and char gasification reactions.

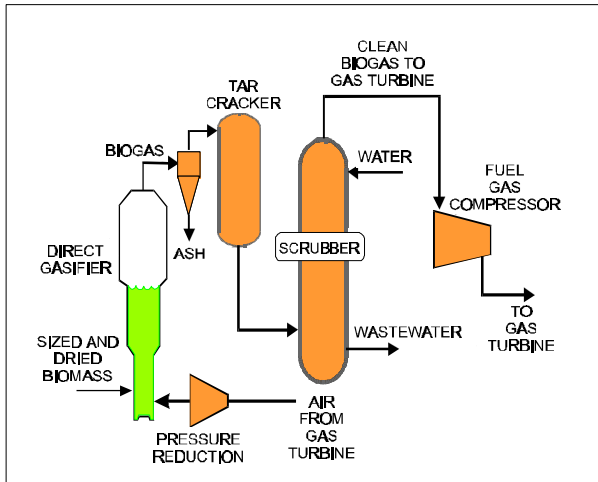

Figure 2. Low-pressure direct gasifier.

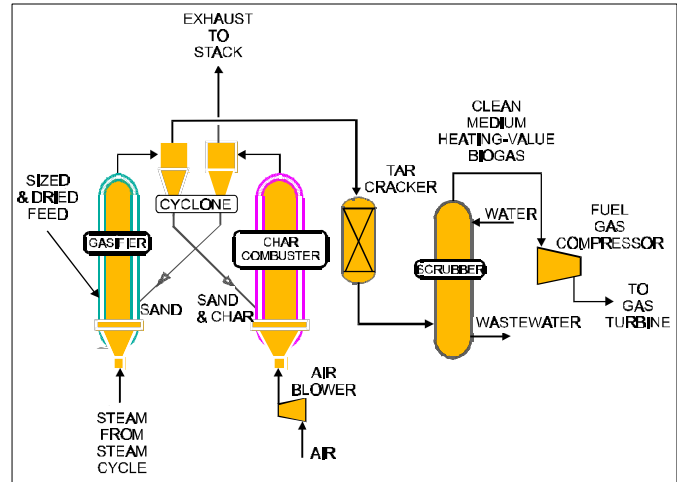

Figure 3. Indirect gasifier.

Currently, indirect gasification systems operate near atmospheric pressure. Direct gasification systems have been demonstrated at both elevated and atmospheric pressures. Any one of the gasifier systems can be utilized in the larger system diagrammed above and have been utilized in at least one recent system design study [1-4].

There are several practical implications of each gasifier type. Due to the diluent effect of the nitrogen in air, fuel gas from a direct gasifier is of low heating value (5.6-7.5 MJ/Nm<sup>3</sup>). This low heat content in turn requires an increased fuel flow to the gas turbine. Consequently, in order to maintain the total (fuel + air) mass flow through the turbine within design limits, an air bleed is usually taken from the gas turbine compressor and used in the gasifier. This bleed air is either boosted slightly in pressure or expanded to near atmospheric pressure depending on the operating pressure of the direct gasifier.

Since the fuel-producing reactions in an indirect gasifier take place in a separate vessel, the resulting fuel gas is free of nitrogen diluent and is of medium heating value (13-18.7 MJ/Nm<sup>3</sup>). This heat content is sufficiently close to that of natural gas (approx. 38 MJ/Nm<sup>3</sup>) that fuel gas from an indirect gasifier can be used in an unmodified gas turbine without air bleed.

Gasifier operating pressure affects not only equipment cost and size, but also the interfaces to the rest of the power plant including the necessary cleanup systems. Since gas turbines operate at elevated pressures, the fuel gas generated by low pressure gasifiers must be compressed. This favors low temperature gas cleaning since the fuel gas must be cooled prior to compression in any case. Air for a low pressure gasifier can be extracted from the gas turbine and reduced in pressure (direct, low pressure gasifier) or supplied independently (indirect gasifier). High pressure gasification favors hot, pressurized cleanup of the fuel gas and supply to the gas turbine combustor at high temperature (~ 538°C or 1,000°F) and sufficiently high pressure for flow control and combustor pressure drop. Air for a high pressure, direct gasifier is extracted from the gas turbine and boosted in pressure prior to introduction to the gasifier.

## GASIFICATION-BASED BIOMASS

Cooling, cold cleanup, and fuel gas compression add equipment to an indirect gasifier system and reduce its efficiency by up to 10% [3,5]. Gasifier and gas cleanup vessels rated for high pressure operation and more elaborate feed systems, however, add cost and complexity to high pressure gasification systems despite their higher efficiency. Results from several recent studies [1-3,5] indicate that, at the current, preliminary grade of estimates (as defined by EPRI TAG [6]) being performed, there is little discernable difference in cost of electricity (COE) between systems employing high and low pressure gasification.

As stated earlier, for the purposes of this analysis, a high-pressure, direct gasification system was selected. The resulting system is very similar to that evaluated in a pre-feasibility study conducted by Northern States Power for NREL and EPRI, reported in NREL/TP-430-20517, and referenced here as "DeLong"[1]. This study examined a 75 MW<sub>e</sub> power plant that would gasify alfalfa stems to provide electricity to the Northern States Power Company and sell the leaf co-product for animal feed. A departure from the DeLong study is the use here of wood as the biomass feedstock. Wood feedstock allows for a more generic plant representation. Alfalfa separation and leaf meal processing steps in the original DeLong study would have added complexity and cost to the plant and have complicated the economic analysis.

Following receipt of wood chips at the plant, they are screened and hogged to a proper size consistency, and dried in a rotary drum dryer. Dried wood is conveyed to storage silos adjacent to the gasifier building. It is then weighed and transferred to a lockhopper/screw feeder system and is fed into the fluidized bed gasifier. The gasifier vendor selected for the DeLong study was Tampella Power Systems (now Carbona) who have developed a commercial version of the IGT RENUGAS™ gasifier. A dolomite feed system is also provided to maintain the inventory of inert material in the bed. In the gasifier, the biomass is gasified at temperatures between 843°C (1550°F) and 954°C (1750°F). The fluidizing and gasifying medium is a mixture of air and steam. Air is extracted from the compressor section of the gas turbine and fed into the gasifier through a boost compressor. Gasification steam is extracted from the steam cycle. The gasifier operates as a so-called spouted bed with intensive circulation of solids from top to bottom which guarantees rapid gasification and maximizes tar cracking.

Fuel gases exiting the gasifier are cooled in the product gas cooler to approximately 538°C (1,000°F). In addition to protecting the fuel flow control valve, this cooling causes the vapor-phase alkali species present in the fuel gas, which could damage the gas turbine, to condense, congeal, and deposit on the fine particulate matter carried over from the gasifier. The combined particulate matter and alkali species are next removed in a Westinghouse hot ceramic candle filter unit to levels within gas turbine tolerances. Since biomass in general and wood in particular are very low in sulfur, a sulfur removal step is not necessary prior to combustion in the gas turbine. Hot cleanup of the fuel gas also minimizes waste water generation from this step of gas processing.

The fuel gas is combusted in a Westinghouse "ECONOPAC" 251B12 gas turbine, producing electric power and a high temperature exhaust stream. A heat recovery steam generator (HRSG) is employed to recover this heat to generate high temperature, high pressure steam that is then expanded in a steam turbine to produce additional power. Steam for the gasifier is extracted from the steam cycle. Finally, electricity for the plant is sent to a substation for voltage step-up. As noted above, the total net electricity output from this system is 75 MW<sub>e</sub>. The cost and performance estimates in Section 4 are based on the evolution of this technology through an "nth" plant and eventually to incorporation of turbines resulting from the DOE Advanced Turbine Systems (ATS) Program.

## GASIFICATION-BASED BIOMASS

As mentioned earlier, several gasifier configurations could have been considered. Converting solid biomass into a gaseous fuel with suitable heating value creates the opportunity to integrate biomass gasifiers with the gas turbine cycles such as the combined gas and steam cycle depicted above. Close coupling of gasification and the power system increases overall conversion efficiency by utilizing both the thermal and chemical energy of hot product gases to fuel the power cycle. Combined cycles, with their high efficiency and low emission characteristics, are a prime choice for biomass gasification systems.

### 2.0 System Application, Benefits, and Impacts

Electricity production from biomass is being used and is expected to continue to be used as base load power in the electricity supply system. A near-term application for biomass gasification is with industrial-scale turbines for repowering of the pulp and paper and sugar cane industries. It has been estimated that roughly 70% of the power houses in the U.S. pulp and paper industry (which represents more than 30% of the world's capacity) will need to be replaced within the next 10-15 years [7]. A similar situation exists in the sugarcane industry. Repowering these plants with modern, efficient, gas turbine technology will substantially improve efficiency, reduce emissions, and provide additional electrical power that can offset purchases or be exported to the surrounding area. A recent study [2] examined a variety of options for mill repowering and found BGCC to be the most economically attractive option. Use of BGCC in the sugarcane industry worldwide could increase the power available for export to the surrounding community by an order of magnitude [8]. This is a significant benefit because many sugar mills are located in developing regions with burgeoning electric power needs. It is worth noting that rapid developments are also being made in smaller turbine sizes as well, and the industrial and cogeneration markets (10-50 MW<sub>e</sub> output) should not be ignored.

As discussed in the Overview of Biomass Technologies, there is approximately 7 GW of grid-connected biomass generating capacity in the U.S. [9], much of it associated with the wood and wood products industry, which obtains more than half its electricity and thermal energy from biomass. In comparison, coal-fired electric units account for 297 GW of capacity, or about 43% of total generating capacity. In 1994, U.S. biomass consumption was approximately 3 EJ, and represented about 3.2% of the 94 EJ of total primary energy consumption [9]. Electricity from biomass represents about 1% of the total U.S. demand. The amount of electricity derived from this quantity of biomass could be roughly doubled if gasification/turbine based power systems were employed (average efficiency of existing capacity = 20%, efficiency of biomass/turbine systems = 35-40%).

Biomass-to-electricity systems based on gasification have a number of potential advantages. Projected process efficiencies are much higher than the direct combustion systems in commercial use today. Process efficiencies are comparable to high efficiency coal-based systems, but can be achieved at a smaller scale of operation. Thus, not only does biomass close the carbon cycle, but gasification based systems, due to their high efficiency, reduce CO<sub>2</sub> emissions per megawatt of power generated over conventional biomass power plants. Biomass is also lower in sulfur than is most U.S. coal. A typical biomass contains 0.05 to 0.20 weight % sulfur on a dry basis and has a higher heating value of about 29.8 MJ/kg (8500 Btu/lb). This compares with coal at up to 2-3 dry weight %. The biomass sulfur content translates to about 51 to 214 mg SO<sub>2</sub>/MJ (0.12 to 0.50 lb SO<sub>2</sub>/MMBtu). The higher sulfur level is still less than the regulated limit set in the current New Source Performance Standards (NSPS). Controlled NO<sub>x</sub> levels from biomass plants will also be less than the NSPS standards.

Since gasifiers operate at much lower temperatures than combustors, gasification allows a wider variety of feedstocks, such as high alkali fuels, than may be technically feasible for direct combustion systems. High alkali fuels such as switchgrass, straws, and other agricultural residues often cause severe corrosion, erosion, and deposition problems on

## GASIFICATION-BASED BIOMASS

heat transfer surfaces in conventional combustion boilers [10]. Gasification systems can easily remove the alkaline species from the fuel gas before it is combusted.

Future technology, such as gasification/fuel cell systems, holds the promise of efficiencies well above 50% even at relatively small scales. Gasifier development potentially benefits other technology areas such as fuels and chemicals through development of gasifier technology which can also be used to generate syngas for chemical synthesis.

The emission data shown in Table 1 are taken from DeLong [1], and are based on alfalfa feed. These data were used rather than estimates generated by the BIOPOWER model [4], since data in the DeLong study were provided by equipment vendors, and the BIOPOWER model is more generic. Since wood is lower in nitrogen than alfalfa, it is expected that the estimate of NO<sub>x</sub> emissions listed here is higher than actual. The ash produced is based on yearly plant feed, assuming biomass is 1.2% ash, as is common for wood. Essentially the same turbine technology is used for these systems through 2010, so the emissions are assumed to be constant. Since advanced turbine systems have not yet been built, emission estimates for later systems were not made. The details of the steam-injected gas turbines (STIG) used in the 2020-2030 cases are not available so boiler blowdown estimates were not made; however, a worst case scenario would have amounts the same as the 2005 case. Future plants will need to meet applicable Federal, state, and local emission requirements.

Table 1. Emissions from a high-pressure, direct gasification system.

Indicator Name	Units	Base Year					
		1997	2000	2005	2010	2020	2030
Particulates (PM10)	g/Nm <sup>3</sup>	0.007	0.007	0.007	0.007		
Nitrogen Oxides@15% O <sub>2</sub>	g/GJ	64.5	64.5	64.5	64.5		
Carbon Monoxide	g/GJ	20.6	20.6	20.6	20.6		
Non-CH <sub>4</sub> Hydrocarbons	g/GJ	9.6	9.6	9.6	9.6		
Sulfur Dioxide	g/GJ	81.8	81.8	81.8	81.8		
Ash	Mg/yr	2,912	2,912	3,883	3,883	4,271	4,271
Boiler blowdown	Mg/yr	6,989	6,989	9,319	9,319		

### 3.0 Technology Assumptions and Issues

The system described is assumed to be in the contiguous U.S., and to have adequate feedstock supply available within a 80.5 km (50 mile) radius. Other assumptions include adequate highway infrastructure, and ready electricity transmission access. The site for the primary reference study [1] is southwestern Minnesota (FERC Region 5). This technology provides a service similar to base load fossil electric generation and cogeneration plants.

It is expected that biomass gasification systems of the type discussed here will be commercially available in the next five years, with the near-term application assumed to be in industrial scale turbines for repowering of pulp/paper and sugar cane industries. Gasifiers have been developed in the U.S. and Europe to produce low- and medium-heating value gases from biomass. In Europe, gasifier systems include fixed-bed gasifiers such as the Bioneer gasifier [11], high pressure gasifiers such as the High Temperature Winkler [12], and circulating fluid bed gasifiers such as the Studsvik [13], Gotaverken [14], Ahlstrom [15] and Lurgi [16].

## GASIFICATION-BASED BIOMASS

In the U.S., gasifiers are being developed by the Institute of Gas Technology (IGT) [17], Battelle Columbus Laboratory (BCL) [18], the University of Missouri at Rolla [19], and Manufacturing and Technology Conversion International [20]. The IGT system is an air/oxygen-blown fluidized bed gasifier while others are indirectly heated gasifiers, using either entrained-flow or fluidized bed reactors. In a jointly funded program, a modified Lurgi-type fixed-bed gasifier using wood chips has been operated. In addition, commercial-scale gasifiers have been operated in the U.S. to produce low-heating-value gas for use as a plant fuel. The status of these systems range from the level of research and development to commercially available for generating low calorific gas. A number of advanced systems, such as the Ahlstrom, TPS/Studsvik, and Institute of Gas Technology and Battelle Columbus Laboratory gasifiers, are considered to be near commercial for generating electricity in combination with commercial gas turbine technology.

The IGT technology is being demonstrated in Hawaii at the 90 Mg/day scale on sugarcane bagasse fuel. The gasifier has run for over 100 hours and is being prepared for a 1500 hour test during late summer 1997 to verify the readiness of the gasification technology as well as the suitability of hot gas filter material for commercial application with biomass fuel. The BCL technology is the subject of a scale-up to 180 Mg/day at the McNeil Generating Station in Burlington, Vermont. These demonstration tests will be fueled by wood chips and the resulting synthesis gas fired in the existing McNeil boiler. Subsequent phases of this project call for installation and testing of a gas turbine of approximately 10 MW<sub>e</sub> capacity. Successful completion of these tests will provide the final data and technology confidence required for scale-up to commercial projects and for obtaining financing for such projects.

The hot gas particulate filter technology used in this characterization was developed by Westinghouse and has been demonstrated in numerous applications from pressurized fluidized bed coal combustion at the Tidd demonstration project through large scale coal gasification at the Sierra Pacific Pinon Pine Clean Coal demonstration project. The filter size used at Tidd has been deemed adequate for biomass gasification applications in the 50-75 MW<sub>e</sub> range. A number of filter elements were tested at the IGT 9 Mg/day pilot gasifier in Chicago, Illinois [21]. This test established the appropriate filter face velocity for use with biomass derived gases and ability of the filters to be cleaned and recover a stable pressure drop across the filter vessel. The results from this test also indicated that sufficient particulate removal was achieved for subsequent use of the gas in a gas turbine. Alkali levels in the exit gas were acceptably low with the exception of sodium. Subsequent analysis of the filter material indicated that long term durability of the filter was a potential issue. For this reason, long-term (1,500 hour) durability tests are being performed at the Hawaii gasification facility to select a more appropriate filter material from those commercially available and to determine whether the sodium levels measured in the pilot plant testing are indicative of actual behavior or an anomaly. These tests should settle any final technical issues surrounding use of hot particulate and alkali removal from biomass synthesis gases.

In addition to efficient technology, an abundant and reliable supply of low-cost biomass feedstock is critical for significant growth to occur in the biomass power industry. The use of biomass residues, about 35 Tg/yr today, is expected to expand throughout the period, reaching about 50 Tg/yr. A key premise of the U.S. National Biomass Power Program is that a dramatic expansion in future availability of dedicated feedstocks will occur in the 2005-2020 time frame, growing to about 90 Tg/yr by 2020.

### 4.0 Performance and Cost

Table 2 summarizes the performance and cost indicators for the high pressure, direct gasification combined cycle system being characterized in this report.

Table 2. Performance and cost indicators.

INDICATOR NAME	UNITS	Base Case 1997		2000		2005		2010		2020		2030	
			+/- %		+/- %		+/- %		+/- %		+/- %		+/- %
Plant Size	MW <sub>e</sub>	75		75		100		100		110		110	
General Performance Indicators													
Capacity Factor	%	80		80		80		80		80		80	
Efficiency	%	36.0		36.0		37.0		37.0		41.5		45.0	
Net Heat Rate	kJ/kWh	10,000		10,000		9,730		9,730		8,670		8,000	
Annual Energy Delivery	GWh/yr	526		526		701		701		771		771	
Capital Cost													
	\$/kW		15		20		20		20		30		30
Fuel Preparation		113		113		101		101		94		86	
Gasifier		519		450		377		346		319		293	
Gas Turbine		216		216		216		198		176		160	
Steam Turbine		48		48		48		44		0		0	
Balance of Plant		311		248		197		147		118		85	
Control System		9		9		9		8		8		7	
Hot Gas Cleanup		43		39		34		31		31		28	
Installation		208		191		157		132		112		99	
Turbine Building		6		6		6		6		6		5	
Waste Pond etc.		2		2		2		2		2		1	
General Plant Facilities		147		132		115		102		87		77	
Engineering Fee		162		145		126		112		95		84	
Proj./Process Contingency		243		218		189		168		143		126	
Startup Costs		56		56		56		51		51		46	
Inventory Capital		10		10		10		9		9		8	
Land @ \$16,060/ha		9		9		7		7		7		6	
<b>Total Capital Requirement</b>		<b>2,102</b>	<b>15</b>	<b>1,892</b>	<b>20</b>	<b>1,650</b>	<b>20</b>	<b>1,464</b>	<b>20</b>	<b>1,258</b>	<b>30</b>	<b>1,111</b>	<b>30</b>

Notes:

1. The columns for "+/- %" refer to the uncertainty associated with a given estimate.
2. Plant construction is assumed to require two years.
3. Totals may be slightly off due to rounding .

Table 2. Performance and cost indicators. (cont.)

INDICATOR NAME	UNITS	Base Case 1997		2000		2005		2010		2020		2030	
			+/- %		+/- %		+/- %		+/- %		+/- %		+/- %
Plant Size	MW <sub>e</sub>	75		75		100		100		110		110	
Operations and Maintenance Cost													
Feed Cost	\$/GJ	2.50	60	2.50	60	2.50	60	2.50	60	2.50	60	2.50	60
Fixed Operating Costs	\$/kW-yr		15		20		25		30		30		30
Operating		22.96		7.13		7.13		7.13		7.13		7.13	
Supervision and Clerical		9.24		5.8		5.8		5.8		5.8		5.8	
Maintenance Labor and Material Costs		36.5		30.47		30.47		30.47		30.47		30.47	
Total Fixed Costs		68.7		43.4		43.4		43.4		43.4		43.4	
Variable Operating Costs	¢/kWh		15		20		25		30		30		30
Labor		0.34		0.34		0.34		0.34		0.34		0.34	
Maintenance Labor and Material Costs		0.06		0.06		0.06		0.06		0.06		0.06	
Total Variable Costs		0.40		0.40		0.40		0.40		0.40		0.40	
Variable Consumables Cost	¢/kWh		15		20		25		30		30		30
Chemicals		0.04		0.04		0.04		0.04		0.04		0.04	
Water		0.06		0.06		0.06		0.06		0.06		0.06	
Ash/Solids Disposal		0.03		0.03		0.03		0.03		0.03		0.03	
Total Consumables		0.12		0.12		0.12		0.12		0.12		0.12	
Total Operating Costs		3.98		3.62		3.55		3.55		3.29		3.12	

Notes:

1. The columns for "+/- %" refer to the uncertainty associated with a given estimate.
2. Total operating costs include feed costs, as well as fixed and variable operating costs.
3. Totals may be slightly off due to rounding .

## GASIFICATION-BASED BIOMASS

### 4.1 Evolution Overview

The 1997 case describes on a high pressure, direct-fired fluidized bed gasifier utilizing hot particulate removal. The system is coupled to a combined cycle power system based on the Westinghouse 251B12 gas turbine with a firing temperature of 1,150°C (2,100°F) and pressure ratio of 15.3. This turbine is available with multi-annular swirl burners (for NO<sub>x</sub> control) designed for natural gas or low heating value synthesis gas. The overall process efficiency for this system is reported as 38.3% in DeLong [1]. The EPRI BIOPOWER model [4] reports the efficiency as 36.0%; however, it was not possible to precisely duplicate all aspects of the system in the BIOPOWER model.

The "power island" (gas turbine and steam cycle) utilized in the base case through the 2010 case is mature, commercially available technology, although minor technical improvements are expected to occur over this time frame. Of particular note are the improvements that will occur in the gasification and hot gas cleanup portions of the plant. The size range of the gas turbines used are available and have been widely demonstrated on natural gas and synthesis gas derived from gasification of coal, residual oil, and petroleum coke. For gas turbine applications, these latter fuels are all more problematic than biomass from a contaminant standpoint. Additionally, an unmodified small gas turbine has been operated directly on fuel gas from the Battelle Columbus Laboratory process development scale gasifier with no difficulties.

Further improvements occur in the 2020 and 2030 cases when ATS-based turbines are employed. These will result from efforts such as DOE's Advanced Turbine Systems Program (ATS) and the industry-lead Collaborative Advanced Gas Turbine (CAGT) development program. These turbines are assumed to have firing temperatures in excess of 1,250°C (2,282°F) and, for the purposes of this study, utilize steam injection for power generation. Such turbines are expected to be available for natural gas use around 2005, thus allowing an additional 15 years for any required research and demonstration of any combustor modifications or turbine "ruggedization" that may be required for synthesis gas use. It should be noted that research on technology required for use of these turbines with coal and biomass is an integral part of the turbine development programs.

### 4.2 Performance and Cost Discussion

The output from the EPRI BIOPOWER model are used for the 1997 base case in Table 2. Heat and material balance data are detailed in Figure 4. The principal departure from the DeLong case is that DeLong uses heat from the combined cycle for alfalfa processing and the alfalfa arrives at the plant with a moisture content of roughly 15% due to in-field drying. The current case assumes that this same amount of heat is instead utilized for wood drying. The heat available is sufficient to reduce wood of approximately 24% moisture to the feed moisture content of 10%. Each additional 10% of feed moisture (i.e. 34% instead of 24%) carries a performance penalty of roughly 1.5 basis points. The feed moisture utilized will result in an average efficiency; proper management of herbaceous crops and some wood wastes can yield lower delivered feed moisture, while some wood feedstocks can be appreciably higher. The steam cycle conditions in BIOPOWER are also somewhat more moderate than those employed in the DeLong study.

Plant availability is based on data in the EPRI TAG [6]. These data are derived from a number of plants currently in operation. For coal gasification combined cycle plants that utilize essentially the same power island technology, availability is 85.7%. For biomass based wood-fired stoker plants (direct combustion steam boiler), the availability is listed as 85%. The equipment in the power island characteristically has availability in excess of 89% in base load operations. Biomass gasification is, in many ways including the severity of process conditions, much simpler than coal gasification. Therefore, it seems that an 85% availability estimate for the entire biomass power plant is



## GASIFICATION-BASED BIOMASS

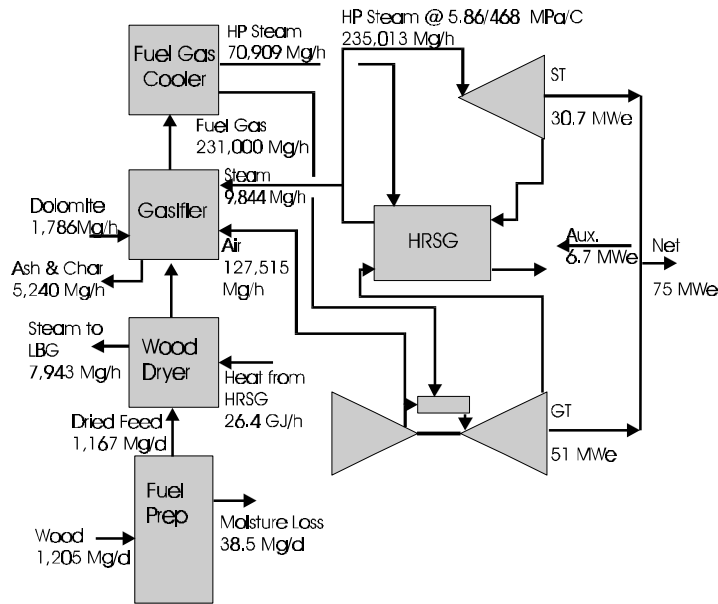

### Energy Balance (GJ/hr)

#### Heat In

Wood to dryer	750.731
C.T. compressor air	23.243
Boiler feed water	-0.493
Dolomite	-3.152
Auxiliary power- MBG compressor	10.237
Other	25.218
Total	805.784

#### Heat Out

Ash and char from gasifier	1.97
Air sep plant effluent	0.698
Solids from hot gas filter	0.026
Combustion turbine power	183.51
Flue gas from combustion turbine	181.231
Steam turbine power output	110.68
Condenser loss	262.506
Blowdown loss	5.208
Generator losses	6.004
Heat losses	53.951
Total	805.784

### Material Balance (Mg/hr)

#### Mass In

Wood to plant	50.245
C.T. Compressor air	680.653
Boiler feed water	9.659
Dolomite	0.893
Total	741.451

#### Mass Out

Fuel prep moisture losses	1.607
Fuel prep fines	0
Fuel prep ferrous metal	0
Ash and char from gasifier	2.620
Air sep plant effluent	16.472
Solids from hot gas filter	0.026
Flue gas from combustion turbine	715.990
Blowdown	4.737
Total	741.451

### Performance Summary

Annual capacity factor, %	80%
Net kJ/kWh	10000
Thermal Efficiency, %	36.0%

Figure 4. Material and energy balance for the 1997 base case.

## GASIFICATION-BASED BIOMASS

reasonable. DeLong [1] also estimates availability to be between 82% and 88% based on experience with the Tampella gasification pilot facility. Based on these data, a plant capacity factor of 80% is assumed.

The cost and performance for the 1997 case are expected to be those for a first plant. All costs are expressed in constant 1997 dollars. A 30-year project life is assumed, after a two year construction period. The electrical substation is part of the general plant facilities, and is not separated out in the factor analysis. The convention followed is that used in the EPRI TAG [6], specifically "It also includes the high-voltage bushing of the generation step-up transformer but not the switchyard and associated transmission lines. The transmission lines are generally influenced by transmission system-specific conditions and hence are not included in the cost estimate."

Cost reductions and performance improvements through 2010 are expected to be largely the result of replication of, and minor technical improvements to, the 1997 case plant. The largest cost reductions occur in the least commercially mature plant sections, i.e. gasification and hot gas cleanup. The first plant costs for these sections normally include very substantial process contingencies and reflects an aggressive equipment "sparing" strategy to guarantee high on-stream factors. As experience is gained with these processes, design details will improve and appropriate maintenance schedules will be developed that minimize the need for large contingencies and spare equipment. Cost reductions also occur in the balance of plant equipment (BOP). In the base, first-of-a-kind case, the BOP cost, taken as a percentage of the other equipment cost, is a very high 35% which again reflects the uncertainties involved in pioneer plants. This is gradually reduced to a more common value of 21% in the mature 2010 case. Overall, these capital costs are reduced by roughly 30% during progression from pioneer plant to mature technology. A similar progression is represented in the EPRI TAG [6] (p. 8-5). Operating labor costs are similarly reduced as more activities can be brought under automated control and operating labor is reduced to a practical minimum.

The gasifier technology is assumed to be largely mature by the 2010 time frame. The fully mature (2010) system costs correlate well with mature plant costs projected by those demonstrating coal gasification combined cycle at a large scale. For example, the \$2,400/kW first plant cost for the Demkolec plant is projected to be \$1,500/kW on a mature technology basis [22]. Similarly, the \$1,646/kW cost for the Puertollano plant declines to \$1,000/kW for the nth plant [22]. The 2010 cost is also consistent with cost data on natural gas fired combined cycle systems. Gas Turbine World [23] reports a turnkey price for a natural gas fired combined cycle plant using the 251B12 turbine of \$713/kW. Adding to this the cost for biomass feed handling and gasification yields a capital cost of approximately \$1,200/kW. This is the lower bound of the nth plant cost posited in Turnure et al. [24] Additional cost reductions beyond 2010 are largely due to improvements in system efficiency which reduce the amount of biomass required (and therefore equipment size) for each megawatt of power generated.

Performance increases from 2000-2010 are the result of gradual improvements to the technology and, in the 2005 case, adoption of more advanced turbine technology using higher firing temperatures (1,288°C, or 2,350°F) and improved steam cycle conditions. The efficiency gains in the 2000 case are assumed to result from improved system integration and the continuing improvement of gas turbine technology. Gas turbines in this size range have increased output and efficiency by 2-4% since 1991 [23].

The ATS program is a \$700 million effort funded by DOE and gas turbine manufacturers that has a target of 60% efficiency (LHV basis) for utility gas turbine combined cycle plants by the year 2000. The industrial turbine portion of the program targets efficiency improvements of at least 15% (from 29 to at least 34% simple cycle efficiency) in the same time period. The ATS program includes in its goals the criteria that the turbines developed be suitable for coal or biomass fuels. It is assumed that this technology will have penetrated the biomass market after the 2010 time frame. As an upper limit, the 60% combined cycle efficiency (LHV basis) goal on natural gas fuel translates into roughly 50% efficiency (HHV basis) on biomass fuel. The higher firing temperatures being utilized by these advanced turbines (up to 1,426°C or 2,600°F) can result in up to 5 basis points improvements in turbine efficiencies. Additional benefits from

## GASIFICATION-BASED BIOMASS

advanced turbines include the use of STIG technology. STIG turbines are commercially available today for natural gas fuels up to approximately 50 MW<sub>e</sub> output at FOB costs of approximately \$280/kW. Increased efficiency, and therefore power output should reduce this cost on a dollar per kilowatt basis. These turbines further reduce system cost by eliminating the need for a steam cycle while still maintaining high specific power output. The 2010 and beyond systems assume that this innovation is available for advanced turbine systems. The 2020-2030 cases utilize cost and efficiency data from Turnure et al. (1995) for early and mature gas turbines utilizing ATS and CAGT technology.

Feed costs in this characterization are expressed in 1997 dollars and represent an update of the DOE feedstock goal for dedicated feedstocks of \$2.50/GJ. If residue feeds are used instead, then feed costs are approximately \$18.7/tonne (\$0.95/GJ; \$1/MMBtu). Depending on the particular application, the use of residue cannot be ruled out even for systems as large as 75 MW<sub>e</sub>. Some pulp and paper and sugarcane mills produce residues within the range of feedstock requirements for systems of this scale. Utilities and others are also examining the use of residues for power production as a service to their customers in need of residue disposal options. The Overview of Biomass Technologies provide a discussion of the sustainability of dedicated feedstock supplies which are assumed to be used in the systems characterized here.

### 5.0 Land, Water, and Critical Materials Requirements

Table 3 provides an overview of the resources required for the biomass gasification systems described here.

Table 3. Resource requirements.

Indicator Name	Units	Base Year					
		1997	2000	2005	2010	2020	2030
Plant Size	MW <sub>e</sub>	75	75	100	100	100	110
Land Plant	ha/MW	0.54	0.54	0.41	0.41	0.41	0.37
	ha	40.5	40.5	40.5	40.5	40.5	40.5
Crops	ha/MW	318	318	207	207	138	138
	ha	23,850	23,850	20,700	20,700	13,800	15,180
Growth rate	Mg/ha/yr	11.20	11.20	16.80	16.80	22.40	22.40
Water (Boiler Feed Water)	Mm <sup>3</sup> /yr	0.07	0.07	0.08	0.08		
Energy: Biomass	PJ/yr	2.26	2.26	2.94	2.94	2.62	2.62
Feedstock: Biomass (dry)	Tg/yr	0.267	0.267	0.346	0.346	0.308	0.308

## GASIFICATION-BASED BIOMASS

Land requirements for the plant proper are assumed to be 40.5 ha@ \$16,060/ha (100 acres@ \$6,500/acre). Feedstock requirements are based on biomass at 19.77 GJ/MT (8,500 Btu/lb), and the capacity factors from Section 4.2. Water requirements are based on results from the BIOPOWER model. Since the details of the steam injected gas turbine technology used in the 2020-2030 cases are not known at this point, a projection for the water requirement was not made. However, it can be expected to be significantly higher since steam injected into a gas turbine is not re-captured as it is in a steam cycle.

Large-scale dedicated feedstock supply systems to supply biomass to biomass power plants are not commercially available in the U.S. today. The U.S. DOE recognizes this fact, and therefore a large part of its commercial demonstration program addresses dedicated feedstock issues. Projects in several locations around the country are developing commercial varieties of woody and herbaceous feedstocks. Development of feedstocks (e.g., hybrid poplar and switchgrass) and resource assessments are also underway at Oak Ridge National Laboratory.

In the forest products (e.g., pulp and paper) and agriculture industries (e.g., sugar) there are many examples that demonstrate the sustainable utilization of biomass residues for power and energy production. Consequently, evidence exists that the agriculture, harvest, transport, and management technologies are capable of supporting power plants of the sizes discussed in this technology characterization.

### 6.0 References

1. DeLong, M., Economic Development Through Biomass Systems Integration - Sustainable Biomass Energy Production, Northern States Power, Minneapolis, MN, for the National Renewable Energy Laboratory, and the Electric Power Research Institute: May 1995. Report NREL/TP-430-20517.
2. Weyerhaeuser, Inc., New Bern Biomass to Energy Project, Phase 1 Feasibility Study, National Renewable Energy Laboratory, Golden, CO: June 1995. Report NREL/TP-421-7942.
3. Craig, K.R., and M.K. Mann, Cost and Performance of Biomass-based Integrated Gasification Combined Cycle Systems, National Renewable Energy Laboratory: January 1996. Report NREL/TP-430-21657.
4. Wiltsee, G., N. Korens, D. Wilhelm, "BIOPOWER: Biomass and Waste-Fired Power Plant Performance and Cost Model," Electric Power Research Institute, Palo Alto, CA: May 1996. Report EPRI/TR-102774, Vol. 1.01.
5. Marrison, C.I., and E.D. Larson, "Cost Versus Scale for Advanced Plantation-Based Biomass Energy Systems in the U.S.," U.S. EPA Symposium on Greenhouse Gas Emissions and Mitigation Research, Washington, D.C., June 27-19, 1995.
6. TAG - Technical Assessment Guide, Volume 1: Electricity Supply—1993, Revision 7, Electric Power Research Institute, Palo Alto, CA, 1993. EPRI/TR-102276-V1R7.
7. Raymond, D., "A Window of Opportunity (Forest Products Industry)," Proceedings of Advanced Turbine Systems - Annual Program Review, Washington, D.C. (November 7-8, 1996).
8. Overend, R.P., and K.R. Craig, "Biomass Energy Resource Enhancement: The Move to Modern Secondary Energy Forms," Proceedings of UNIDO Symposium on Development and Utilization of Biomass Energy Resources in Developing Countries, Vienna, Austria (December 1995).

## GASIFICATION-BASED BIOMASS

9. U.S. Department of Energy, Energy Information Agency, Annual Energy Outlook 1997, DOE/EIA-0383(97), Washington, D.C., 1996.
10. Miles, T.R., et al., Alkali Deposits Found in Biomass Power Plants. A Preliminary Investigation of Their Extent and Nature, National Renewable Energy Laboratory, Golden, CO: February 1996. Report NREL/TP-433-8142.
11. Kurkela, E., P. Ståberg, P. Simell, and J. Leppälähti, "Updraft Gasification of Peat and Biomass, Biomass," January 1989, pp. 12-19.
12. Koljonen, J., "Peat, a Raw Material for Ammonia," Proceedings of the International Fertilizer Industry Association Technical Conference, Venice, Italy (1990).
13. Dhargalkar, P.H., "A Unique Approach to Municipal Waste Management in Chianti, Italy," Proceedings of the Municipal Waste Combustion Conference sponsored by EPA and the Air and Waste Management Association, Tampa, FL (April 1991).
14. Olauson, L., "Biomass Gasification at the Värö Pulp Mill," Proceedings of the International Energy Agency (IEA) Biomass Gasification Working Group Meeting, Espoo, Finland, (September 17-19, 1991).
15. Lyytinen, H., "Biomass Gasification as a Fuel Supply for Lime Kilns; Description of Recent Installations," TAPPI Journal, July 1991, pp. 77-80.
16. Loeffler, J., and P.K. Herbert, ACFB and PCFB Gasification of Biomass, Garbage and Coals for the Generation of Fuel, Synthesis Gas, and Electricity, presented at the IEA Biomass Gasification Working Group Meeting, Espoo, Finland (September 17-20, 1991).
17. Evans, R.J., R.A. Knight, M. Onishak, and S.P. Babu, Development of Biomass Gasification to Produce Substitute Fuels, Institute of Gas Technology, Chicago, IL, for Pacific Northwest Laboratory, Richland, WA: May 1988. Report PNL-6518/UC-245.
18. Feldmann, H.F., M.A. Paisley, H.R. Applebaum, and D.R. Tayler, Conversion of Forest Residues to a Methane-Rich Gas in a High Throughput Gasifier, Battelle Columbus Laboratories, Columbus, OH, for Pacific Northwest Laboratory, Richland, WA: May 1988. Report PNL-6570/UC-245.
19. Flanigan, V.J., O.C. Sitton, and W.E. Huang, The Development of a 20-inch Indirect Fired Fluidized Bed Gasifier, University of Missouri at Rolla, Rolla, Missouri, for Pacific Northwest Laboratory, Richland, Washington: March 1988. Report PNL-6520/UC-245.
20. Schiefelbein, G.F., Testing of an Advanced Thermochemical Conversion Reactor System, Manufacturing and Technology Conversion International, Inc., Columbia, Maryland. 1990. Report PNL-7245/UC-245.
21. Wiant, B.C., D.M. Bachovchin, and M.A. Alvin, "Testing Status of the Biomass Gasification Hot Gas Cleanup Demonstration Program," Proceedings of the Second Biomass Conference of the Americas, Portland, OR, Report NREL/CP-200-8098 (August 21-24, 1995).
22. Stambler, I., "Refinery IGCCs Producing Electric Power, Steam, High Value Products," Gas Turbine World. Vol. 26, No. 6, pp. 16-24 (November 1996).

## **GASIFICATION-BASED BIOMASS**

23. Gas Turbine World 1996 Handbook, Volume 17, Pequot Publishing Inc., Fairfield, CT.
24. Turnure, J.T., S. Winnet, R. Shackleton, and W. Hohenstein, "Biomass Electricity: Long-Run Economic Prospects and Climate Policy Implications," Proceedings from the Second Biomass Conference of the Americas, Portland , OR., Report NREL/CP-200-8098, pp. 1418-1427, (August 21-24, 1995).

## DIRECT-FIRED BIOMASS

### 1.0 System Description

The technologies for the conversion of biomass for electricity production are direct combustion, gasification, and pyrolysis. As shown in Figure 1, direct combustion involves the oxidation of biomass with excess air, producing hot flue gases which in turn produce steam in the heat exchange sections of boilers. The steam is used to generate electricity in a Rankine cycle; usually, only electricity is produced in a condensing steam cycle, while electricity and steam are cogenerated in an extracting steam cycle. Today's biomass-fired steam cycle plants typically use single-pass steam turbines. However, in the past decade, efficiencies and more complex design features, characteristic previously of only large scale steam turbine generators (> 200 MW), have been transferred to smaller capacity units. Today's biomass designs include reheat and regenerative steam cycles as well as supercritical steam turbines. The two common boiler configurations used for steam generation with biomass are stationary- and traveling-grate combustors (stokers) and atmospheric fluid-bed combustors.

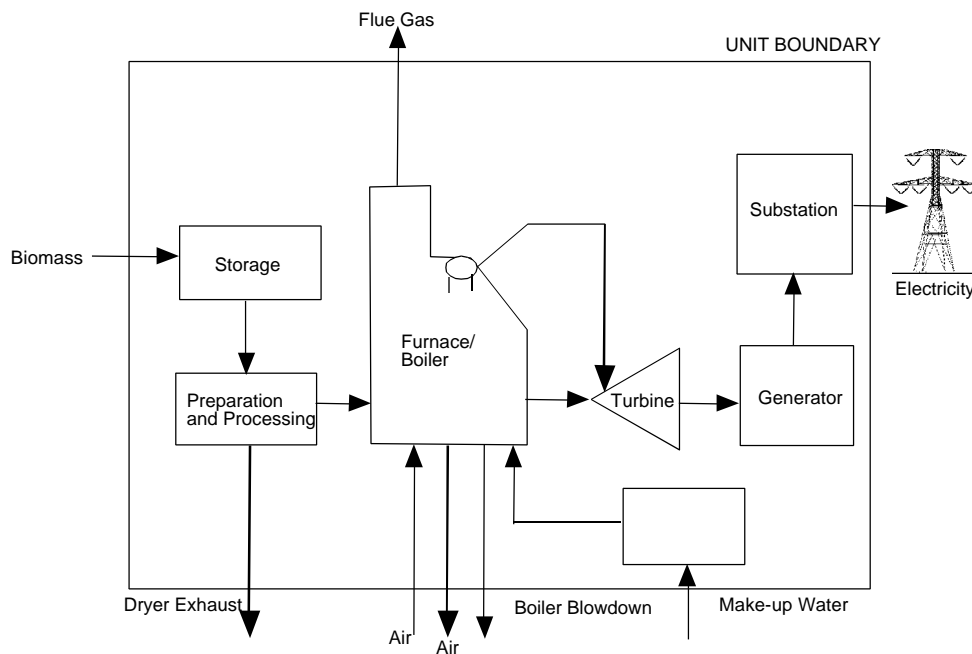

Figure 1. Direct-fired biomass electricity generating system schematic.

All biomass combustion systems require feedstock storage and handling systems. The 50 MW McNeil station, located in Burlington, Vermont, uses a spreader-stoker boiler for steam generation, and has a typical feed system for wood chips [1]. Whole tree chips are delivered to the plant gate by either truck or rail. Fuel chips are stored in open piles (about a 30 day supply on about 3.25 ha of land), fed by conveyor belt through an electromagnet and disc screen, then fed to surge bins above the boiler by belt conveyors. From the surge bins, the fuel is metered into the boiler's pneumatic stokers by augers.

The base case technology is a commercially available, utility operated, stoker-grate biomass plant constructed in the mid-1980's [2], and is representative of modern biomass plants with an efficiency of about 23%. Plant efficiency of the stoker plant increases to 27.7% in the year 2000 through the use of a dryer, and in 2020 plant efficiency is increased to 33.9% due to larger scale plants which permit more severe steam turbine cycle conditions, e.g. higher pressure, higher temperature and reheat.

## DIRECT-FIRED BIOMASS

### Direct Fire Technologies

Pile burners represent the historic industrial method [3] of wood combustion and typically consist of a two-stage combustion chamber with a separate furnace and boiler located above the secondary combustion chamber. The combustion chamber is separated into a lower pile section for primary combustion and an upper secondary-combustion section. Wood is piled about 3.3 m (10 ft) deep on a grate in the bottom section and combustion air is fed upward through the grate and inwards from the walls; combustion is completed in a secondary combustion zone using overfire air. The wood fuel is introduced either on top of the pile or through an underfeed arrangement using an auger. The underfeed arrangement gives better combustion control by introducing feed underneath the active combustion zone, but it increases system complexity and lowers reliability. Ash is removed by isolating the combustion chamber from the furnace and manually dumping the ash from the grate after the ash is cooled. Pile burners typically have low efficiencies (50% to 60%), have cyclic operating characteristics because of the ash removal, and have combustion cycles that are erratic and difficult to control. Because of the slow response time of the system and the cyclic nature of operation, pile burners are not considered for load-following operations. The advantage of the pile burner is its simplicity and ability to handle wet, dirty fuels.

Stoker combustors [3] improve on operation of the pile burners by providing a moving grate which permits continuous ash collection, thus eliminating the cyclic operation characteristic of traditional pile burners. In addition, the fuel is spread more evenly, normally by a pneumatic stoker, and in a thinner layer in the combustion zone, giving more efficient combustion. Stoker-fired boilers were first introduced in the 1920's for coal, and in the late 1940's the Detroit Stoker Company installed the first traveling grate spreader stoker boiler for wood. In the basic stoker design, the bottom of the furnace is a moving grate which is cooled by underfire air. The underfire air rate defines the maximum temperature of the grate and thus the allowable feed moisture content. More modern designs include the Kabliz grate, a sloping reciprocating water-cooled grate. Reciprocating grates are attractive because of simplicity and low fly ash carryover. Combustion is completed by the use of overfire air. Furnace wall configurations include straight and bulb nose water walls. Vendors include Zurn, Foster Wheeler, and Babcock and Wilcox.

In a gas-solid fluidized-bed, a stream of gas passes upward through a bed of free-flowing granular materials. The gas velocity is high enough that the solid particles are widely separated and circulate freely, creating a "fluidized-bed" that looks like a boiling liquid and has the physical properties of a fluid. During circulation of the bed, transient streams of gas flow upwards in channels containing few solids, and clumps or masses of solids flow downwards [4]. In fluidized-bed combustion of biomass, the gas is air and the bed is usually sand or limestone. The air acts both as the fluidizing medium and as the oxidant for biomass combustion. A fluidized-bed combustor is a vessel with dimensions such that the superficial velocity of the gas maintains the bed in a fluidized condition at the bottom of the vessel. The cross-sectional area changes above the bed and lowers the superficial gas velocity below fluidization velocity to maintain bed inventory and act as a disengaging zone. Overfire air is normally introduced in the disengaging zone. To obtain the total desired gas-phase residence time for complete combustion and heat transfer to the boiler walls, the larger cross-sectional area zone is extended and is usually referred to as the freeboard. A cyclone is used to either return fines to the bed or to remove ash-rich fines from the system. The bed is fluidized by a gas distribution manifold or series of sparge tubes [5].

If the air flow of a bubbling fluid bed is increased, the air bubbles become larger, forming large voids in the bed and entraining substantial amounts of solids. This type of bed is referred to as a turbulent fluid bed [6]. In a circulating fluid bed, the turbulent bed solids are collected, separated from the gas, and returned to the bed, forming a solids circulation loop. A circulating fluid bed can be differentiated from a bubbling fluid bed in that there is no distinct separation between the dense solids zone and the dilute solids zone. The residence time of the solids in a circulating fluid bed is determined by the solids circulation rate, the attritability of the solids, and the collection efficiency of the



## DIRECT-FIRED BIOMASS

solids separation device. As with bubbling fluid beds, emissions are the primary driving force behind the development of circulating fluid beds in the U.S. The uniform, low combustion temperatures yield low  $\text{NO}_x$  emissions. In a circulating fluid bed, with its need for introduction of solids to maintain bed inventory, it is easy to introduce a sorbent solid, such as limestone or dolomite, to control  $\text{SO}_2$  emissions without the need for back-end sulfur removal equipment. Circulating fluid bed temperatures are maintained at about  $870^\circ\text{C}$  ( $1,598^\circ\text{F}$ ), which help to optimize the limestone-sulfur reactions [7]. The major manufacturers of circulating fluid bed boilers for biomass are Combustion Engineering (CE-Lurgi), B&W-Studsvik, Ahlstrom Pyropower (Foster Wheeler) and Gotaverken. A number of plants have been built in the 25 MW size range, primarily in California.

The suspension burning of pulverized wood in dedicated biomass boilers is a fairly recent development and is practiced in relatively few installations. Suspension burning has also been accomplished in lime kilns [8] and is being investigated by the utility industry for co-firing applications [9]. Successful suspension firing requires a feed moisture content of less than 15% [3] and a particle size less than 0.15 cm [8]. These requirements give higher boiler efficiencies (up to 80%) than stoker grate or fluid bed systems (65% efficiency), which fire wet wood chips (50-55% moisture). The higher efficiency of suspension burners results in smaller furnace size. Offsetting the higher efficiency is the cost and power consumption of drying and comminution. In addition, special burners (i.e. scroll cyclonic burners and vertical-cylindrical burners) are required [3]. Installations include the 27 MW Oxford Energy facility at Williams, California [3]; the ASSI Lövholmen Linerboard Mill in Piteå, Finland [10]; the Klabin do Parana mill in Monte Alegre, Brazil [8]; and the E.B. Eddy Mill in Espanola Ontario [8].

The Whole Tree Energy™ Process is being developed by Energy Performance Systems, Minneapolis, Minnesota [11], as an integrated wood-conversion process encompassing feedstock production, harvesting, transportation, and conversion to electricity. Elements of the process have been tested, but the system has not been run as an integrated process. The concept involves transporting whole trees to the conversion facility where drying will be accomplished over a 30-day period using low temperature heat from the power island. Trees will be transported to the power island where they will be cut to the desired length and introduced into the primary combustion chamber through a ram charger door. The primary combustion chamber is envisioned as a deep bed operated as a substoichiometric combustor to produce a mixture of combustion products and volatilized organics. The gases leaving the primary combustion chamber will be burned with overfire air under excess air conditions to complete the combustion process. The boiler will be a standard design with superheater and economizer. The steam turbine cycle will be comparable to modern cycles utilizing 16.54 MPa,  $538^\circ\text{C}$  ( $1000^\circ\text{F}$ ) steam. The potential advantages of the Whole Tree Energy™ process are reduced operating costs achieved by elimination of wood chipping, and increased efficiency by almost complete use of waste heat in the condensing heat exchange system.

### 2.0 System Application, Benefits, and Impacts

Electricity production from biomass is being used, and is expected to continue to be used, as base load power in the existing electrical distribution system. As discussed in the Overview of Biomass Technologies, there are approximately 7 GW of grid-connected biomass generating capacity in the U.S. [12]. Much of this is associated with the wood and wood products industries that obtain over half of their electricity and thermal energy from biomass. All of today's capacity is direct combustion/Rankine cycle technology. Biomass consumption in 1994 reached approximately 3 EJ, representing about 3.2% of the total U.S. primary energy consumption (94 EJ) [12].

There are a number of benefits of using biomass-derived electricity. Biomass is lower in sulfur than most U.S. coals. A typical biomass contains 0.05 to 0.20 weight % sulfur and has a higher heating value of about 19.77 MJ/kg. This sulfur content translates to about 51 to 214 mg  $\text{SO}_2/\text{MJ}$ . The higher level is still less than the regulated limit set out in the current New Source Performance Standards (NSPS) for coal: 517 mg/MJ for coal-fired plants that have achieved

## DIRECT-FIRED BIOMASS

a 90% reduction in emissions since 1985 and 259 mg/MJ for coal-fired plants that have achieved a 70% reduction in emissions since 1985 [13]. Controlled NO<sub>x</sub> levels from biomass plants will also be less than the NSPS standards. Biomass is a renewable resource that consumes carbon dioxide during its growing cycle. Therefore, it contributes no net carbon dioxide to the atmosphere when biomass is produced and consumed on a sustainable basis as part of a dedicated feedstock supply system/energy production system. The use of biomass to produce electricity in a dedicated feedstock supply system/electricity-generation system will provide new revenue sources to the U.S. agriculture system by providing a new market for farm production. The gaseous and particulate emissions shown in Table 1 are performance guarantees for existing biomass power plants in California [3]. The ash produced is based on yearly plant feed, assuming biomass with 0.69% ash. Since advanced direct combustion systems have not been built, emission estimates have not been made. Future plants will need to meet applicable Federal, state, and local emission requirements.

Table 1. Biomass power plant gaseous and particulate emissions.

Indicator Name	Units	Base Year					
		1997	2000	2005	2010	2020	2030
Unit Size	MW	50	60	100	150	184	184
Traveling Grate							
Particulates (@ 12% CO <sub>2</sub> )	g/Nm <sup>3</sup>	0.054					
Nitrogen Oxides	g/GJ	4.30					
Carbon Monoxide	g/GJ	129					
Non-CH <sub>4</sub> Hydrocarbons	g/GJ	17.2					
Sulfur Dioxide	g/GJ	Not specified					
Ash	Gg/yr	2.042	2.042	3.393	5.088	5.088	5.088

### 3.0 Technology Assumptions and Issues

The base technology is assumed to be located in New England (FERC Region 1), which is considered a representative region. The use of biomass power could be widespread, and is excluded only from desert regions. In 1994, of the 3 EJ of biomass energy consumed in the U.S., 1.055 EJ were used to produce power [12]. These values include biomass residues, municipal solid waste, and landfill gas. Although biomass is being used to produce power in many locations across the U.S., biomass electricity production is currently concentrated in New England, the South Atlantic, and the West (FERC Regions 1, 4, and 9, respectively).

An abundant and reliable supply of low-cost biomass feedstock is critical for significant growth to occur in the biomass power industry. The use of biomass residues, about 35 Tg/yr today, is expected to expand throughout the period, reaching about 50 Tg/yr. A key premise of the U.S. National Biomass Power Program is that a dramatic expansion in future availability of dedicated feedstocks will occur in the 2005-2020 time frame, growing to about 90 Tg/yr by 2020. For purposes of this analysis, the use of dedicated feedstock is assumed.

Direct-fired biomass technology will provide base-loaded electricity and is operated in a way similar to fossil and nuclear plants. Direct-fired biomass technology is commercial technology. All of the assumed advances in performance involve the incorporation of proven commercial technology. Therefore, there are no R&D issues involved in the power station technology. However, there is R&D required to determine additives and boiler modifications to permit the combustion of high-alkali biomass, such as wheat straw, without fouling of boiler heat exchange surfaces.

## DIRECT-FIRED BIOMASS

### 4.0 Performance and Cost

Table 2 summarizes the performance and cost indicators for the direct-fired biomass system being characterized in this report.

### 4.1 Evolution Overview

The base case is based on the McNeil Station located in Burlington, Vermont, as described by Wiltsee and Hughes [1]. Feed composition is given in Table 3. Wood heating values are about 10 MJ/kg on a wet basis and 20 MJ/kg on a dry basis; these values are about 40% and 80% of coal (24.78 MJ/kg [12]), respectively.

Table 3. Feedstock composition.

Component	Pine		Oak	
	5%M	50%M	5%M	50%M
C, wt%	50.45	26.55	47.65	25.08
H	5.74	3.02	5.72	3.01
N	0.16	0.09	0.09	0.05
O	37.34	19.66	41.17	21.65
S	0.02	0.01	0.01	0.01
Cl	0.03	0.01	0.01	0.01
Moisture	5.00	50.00	5.00	50.00
Ash	1.26	0.67	0.35	0.19
MJ/kg (wet)	19.72	10.38	18.92	9.96
MJ/kg (dry)	20.76	20.76	19.92	19.92

Representative material and energy balances for the 1996 and 2000 cases are given by Figures 2 and 3. The nameplate efficiency of the McNeil Station is 25%, while the Biopower model [14] from which Figure 2 was derived, gives 23.0% efficiency.

As indicated in Figure 3, the plant efficiency is increased to 27.7% in the year 2000 (EPRI 1995) through the use of a dryer. This increase in efficiency comes from an increase in boiler efficiency that occurs when dry feed is substituted for wet feed. For example, for a wood-fired stoker boiler, boiler efficiency is estimated at 70% for a 50% moisture content fuel and 83% for a 10% moisture content fuel, assuming 30% excess air, 19.96 MJ/kg dry feed, and a flue gas exit temperature of 177°C (351°F) [1]. The McNeil Station boiler efficiency is 70% for a 50% moisture fuel and its process efficiency is 23%. Wiltsee states “The boiler efficiency, multiplied by the higher heating value of the fuel burned in the boiler, determines the amount of energy that ends up in the steam, available for driving the steam turbine generator. The boiler efficiency also determines the gross station efficiency when it is multiplied by the gross turbine efficiency. Boiler efficiency is a function of the amount of moisture in the fuel, the amount of

Table 2. Performance and cost indicators.

INDICATOR NAME	UNITS	Base Case 1997		2000		2005		2010		2020		2030	
			+/- %		+/- %		+/- %		+/- %		+/- %		+/- %
Plant Size	MW	50		60		100		150		184		184	
General Performance Indicators													
Capacity Factor	%	80		80		80		80		80		80	
Efficiency	%	23.0		27.7		27.7		27.7		33.9		33.9	
Net Heat Rate	kJ/kWh	15,280		13,000		13,000		13,000		10,620		10,620	
Annual Energy Delivery	GWh/yr	350		420		700		1,050		1,290		1,290	
Capital Cost													
Fuel Preparation	\$/kW	181	20	150	20	129	20	114	20	93	20	93	20
Dryer		0		79		68		60		49		49	
Boiler		444	25	369	25	317	25	281	25	229	25	229	25
Baghouse & Cooling Tower		29		24		21		18		15		15	
Boiler feed water/deaerator		56	25	46	25	40	25	35	25	29	25	29	25
Steam turbine/gen		148		123		106		94		76		76	
Cooling water system		66		55		47		42		34		34	
Balance of Plant		273	15	227	15	195	15	172	15	141	15	141	15
Subtotal (A)		1,197		1,073		922		816		667		667	
General Plant Facilities (B)		310		257		221		196		160		160	
Engineering Fee, 0.1*(A+B)		1,513		133		114		101		83		83	
Project /Process Contingency		2,269		200		171		152		124		124	
Total Plant Cost		1,884		1,664		1,429		1,265		1,034		1,034	
Prepaid Royalties		0		0		0		0		0		0	
Init Cat & Chemical Inventory		2.21		2.21		2.21		2.21		2.21		2.21	
Startup Costs		53.06		53.06		53.06		53.06		53.06		53.06	
Inventory Capital		11.19		11.19		11.19		11.19		11.19		11.19	
Land, @\$16,060/hectare		14.49		14.49		14.49		14.49		14.49		14.49	
Total Capital Requirement	\$/kW	1,965		1,745		1,510		1,346		1,115		1,115	

Notes:

1. The columns for "+/- %" refer to the uncertainty associated with a given estimate .
2. Plant construction is assumed to require two years.
3. Totals may be slightly off due to rounding

Table 2. Performance and cost indicators. (cont.)

INDICATOR NAME	UNITS	Base Case		2000		2005		2010		2020		2030	
		1997	+/- %		+/- %		+/- %		+/- %		+/- %		+/- %
Plant Size	MW	50		60		100		150		184		184	
Operation and Maintenance Cost													
Feed Cost	\$/GJ	2.50	60	2.50	60	2.50	60	2.50	60	2.50	60	2.50	60
Fixed Operating Costs	\$/kW-yr	73	15	60	15	60	15	60	15	49	15	49	15
Variable Operating Costs	¢/kWh												
Labor		0.37	15	0.30	15	0.30	15	0.30	15	0.25	15	0.25	15
Maintenance		0.21		0.17		0.17		0.17		0.14		0.14	
Consumables		0.27		0.23		0.23		0.23		0.18		0.18	
Total Variable Costs		0.85		0.70		0.70		0.70		0.57		0.57	
Total Operating Costs	¢/kWh	5.50		4.74		4.74		4.74		3.87		3.87	

Notes:

1. The columns for "+/- %" refer to the uncertainty associated with a given estimate .
2. Total operating costs include feed costs, as well as fixed and variable operating costs.
3. Totals may be slightly off due to rounding

## DIRECT-FIRED BIOMASS

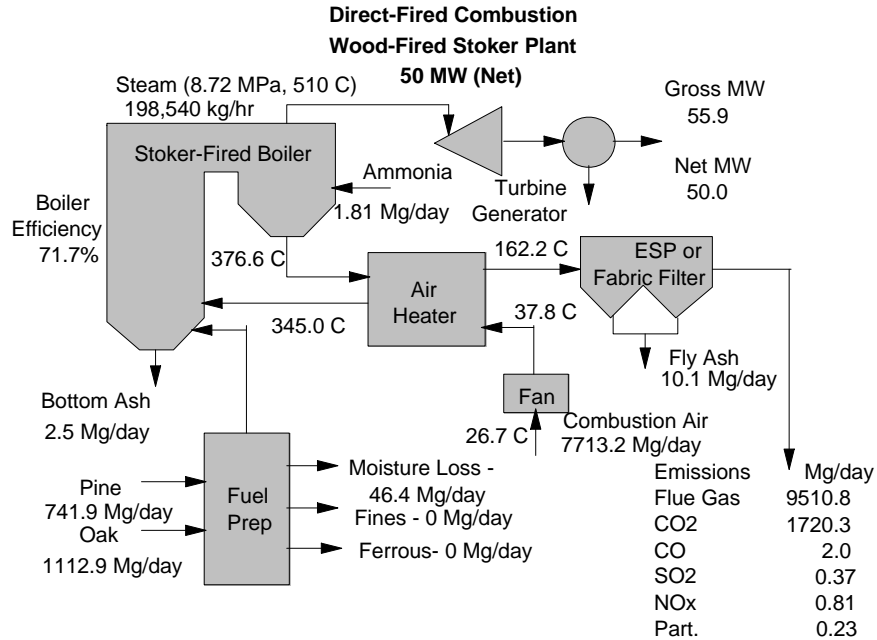

### Energy Balance (GJ/hr)

#### Heat In

Fuel (as fired)	782.5
<b>Total</b>	<b>782.5</b>

#### Heat Out

Net stream turbine output	180.1
Auxiliary turbine use	21.1
Condenser	360.3
Stack gas losses	199.5
Boiler radiation losses	2.0
Unaccounted carbon loss	7.8
Unaccounted boiler heat loss	11.7
<b>Total</b>	<b>782.5</b>

### Material Balance (Mg/hr)

#### Mass In

Fuel (as received)	77.3
Ammonia	0.1
Combustion Air	321.4
<b>Total</b>	<b>398.7</b>

#### Mass Out

Fuel prep moisture losses	1.9
Fines	0.0
Ferrous metal	0.0
Bottom ash	0.3
Fly ash	1.0
Flue gas	396.3
<b>Total</b>	<b>398.7</b>

### Performance Summary

Annual capacity factor, %	80%
Net KJ/kWh	15,650
Thermal Efficiency, %	23.0%

Figure 2. Material and energy balance for the 1997 base case.

## DIRECT-FIRED BIOMASS

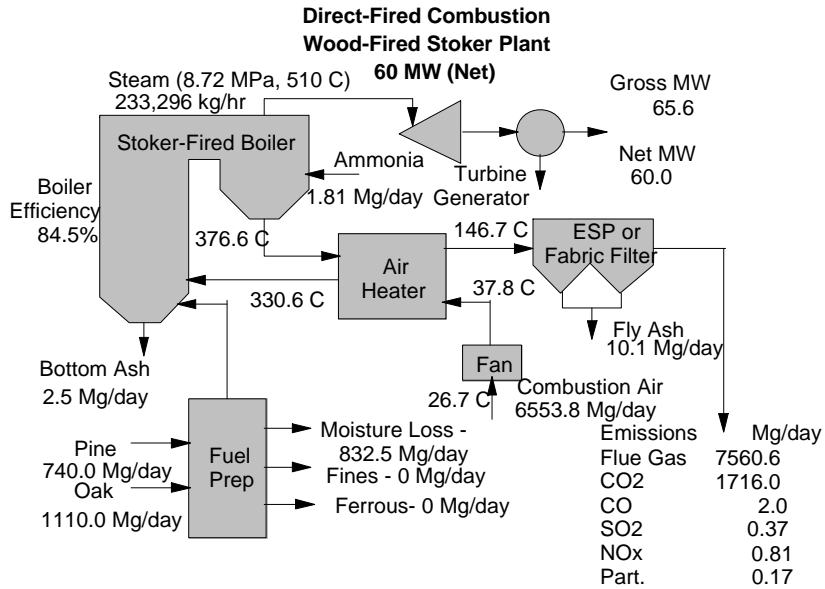

### Energy Balance (GJ/hr)

#### Heat In

Fuel (as fired)	782.5
Total	782.5

#### Heat Out

Net stream turbine output	216.1
Auxiliary turbine use	20.4
Condenser	423.3
Stack gas losses	99.4
Boiler radiation losses	1.9
Unaccounted carbon loss	7.8
Unaccounted boiler heat loss	11.7
Total	780.5

### Material Balance (Mg/hr)

#### Mass In

Fuel (as received)	77.1
Ammonia	0.1
Combustion Air	273.1
Total	350.3

#### Mass Out

Fuel prep moisture losses	34.6
Fines	0.0
Ferrous metal	0.0
Bottom ash	0.1
Fly ash	0.5
Flue gas	315.0
Total	350.3

### Performance Summary

Annual capacity factor	80%
Net KJ/kWh	13,008
Thermal Efficiency	27.7%

Figure 3. Material and energy balance for the year 2000 case.

## DIRECT-FIRED BIOMASS

excess air used in the combustion process, and the amount of heat lost in the heat transfer process, which is largely a function of boiler design.” If we multiply the McNeil Station design efficiency by 83/70, we get 27.3% efficiency .

In 2020, plant efficiency is increased to 33.9% [1] through more severe steam turbine cycle conditions possible at larger scale, e.g., higher pressure, higher temperature, and reheat. For example, Wiltsee and Hughes [1] provide an example of a 50 MW stoker plant, compared to a 100 MW WTE™plant and state “As shown, the WTE™steam turbine (7,874 Btu/kWh) is much more efficient than the stoker power plant’s steam turbine (9,700 Btu/kWh). This is because of the WTE™steam turbine’s larger size (106 vs. 59 gross MW), and higher steam conditions (2,520 psig and 1,000 °F with 1,000°F reheat, vs. 1,250 psig and 950°F, with no reheat).” If one multiplies the 27.7% efficiency case by the ratio 9,700/7,864, one gets 34.1%, which is comparable to the Biopower model results of 33.9%.

### 4.2 Performance and Cost Discussion

The base case capital and operating costs [1] were updated to 1996 dollars using the Marshall and Swift Index [15]. In the year 2000, plant costs were adjusted by adding a dryer [16]. Capital and operating costs in later years were scaled from the 2000 values using a 0.7 scaling factor. Peters and Timmerhaus [17] state “It is often necessary to estimate the cost of a piece of equipment when no cost data are available for the particular size of operational capacity involved. Good results can be obtained by using the logarithmic relationship known as the ‘six-tenths-factor rule,’ if the new piece of equipment is similar to one of another capacity for which cost data are available. According to this rule, if the cost of a given unit at one capacity is known, the cost of a similar unit with X times the capacity of the first is approximately  $(X)^{0.6}$  times the cost of the initial unit.” Valle-Riesta [18] states “A logical consequence of the ‘six-tenths-factor’ rule for characterizing the relationship between equipment capacity and cost is that a similar relationship should hold for the direct fixed capital of specific plants....In point of fact, the capacity exponent for plants, on the average, turns out to be closer to 0.7.” The exception to this rule happens when plant capacity is increased by change in efficiency, not change in equipment size. In this case, capital cost in dollars remains constant, and capital cost in \$/kW decreases in proportion to efficiency increase. For example, the change in capital costs between 1996 and 2000 reflects an efficiency increase, while the change between 2000 and 2005 reflects equipment scale change.

The electrical substation is part of the general plant facilities, and is not separated out in the factor analysis. The convention follows that used in the EPRI Technical Assessment Guide [12], as follows “It also includes the high-voltage bushing of the generation step-up transformer but not the switchyard and associated transmission lines. The transmission lines are generally influenced by transmission system-specific conditions and hence are not included in the cost estimate.”

Feedstock for biomass plants can be residues or dedicated crops or a mixture of the two. For purposes of this analysis, dedicated feedstock is assumed. The Overview of Biomass Technologies provides a discussion of the sustainability of dedicated feedstock supplies which are assumed to be used in the systems characterized here. Fuel from dedicated feedstock supply systems is projected to cost as little as \$1/GJ and as much as \$4/GJ, depending on species and conditions [1]. For this analysis, an average cost of \$2.50/GJ is used, which represents an update of the DOE goal for dedicated feedstocks.



## DIRECT-FIRED BIOMASS

### 5.0 Land, Water, and Critical Materials Requirements

Storage requirements are included in both the station and cropland area estimates shown in Table 4. About one week of storage at the plant site is assumed. Transfer stations are included in land estimates. Feedstock requirements are based on biomass at 19.77 GJ/MT (8,500 Btu/lb), and the capacity factors from Table 2.

As discussed in the Overview of Biomass Technologies, large-scale dedicated feedstock supply systems to supply biomass to biomass power plants do not exist in the U.S. today. Because the U.S. DOE has recognized this fact, a large share of its commercial demonstration program directly addresses dedicated feedstock supply. Projects in New York, Iowa, and Minnesota are developing commercial feedstocks of both woody and herbaceous varieties. Feedstock development (e.g., hybrid poplar and switchgrass) and resource assessment are also underway at Oak Ridge National Laboratory.

Furthermore, many examples in the forest products industries (e.g., pulp and paper) and agriculture industries (e.g., sugar) demonstrate sustainable utilization of biomass residues for power and energy production. In the U.S. and abroad, numerous examples demonstrate that the agriculture, harvest, transport, and management technologies exist to support power plants of the proportions discussed in this technology characterization.

Table 4. Resource requirements.

Indicator Name	Units	Base Year					
		1996	2000	2005	2010	2020	2030
Plant Size	MW	50	60	100	150	184	184
Land Plant	ha/MW	0.902	0.902	0.902	0.902	0.902	0.902
	ha	45.1	54.1	90.2	135.3	166.0	166.0
Crops	ha/MW	487	401	268	268	164	164
	ha	24,350	24,060	26,800	40,200	30,176	30,176
Crop Growth Rate	Mg/ha/yr	11.2	11.2	16.8	16.8	22.4	22.4
Power Plant Water	Mm <sup>3</sup> /yr	0.808	0.808	1.341	2.012	2.426	2.426
Energy: Biomass	PJ/yr	5.35	5.35	8.90	13.34	13.34	13.34
Feedstocks: Biomass	Tg/yr	0.271	0.271	0.450	0.675	0.675	0.675
Labor							
	Farm (261 ha/FTE)	FTE	95	95	101	152	114
Station	FTE	22	22	22	30	35	35

Note: FTE refers to full-time equivalent.

## DIRECT-FIRED BIOMASS

### 6.0 References

1. Wiltsee, G.A., and E. E. Hughes, Biomass Energy: Cost of Crops and Power, Vol. 2, Electric Power Research Institute, Palo Alto, CA: 1995. Report TR-102107.
2. TAG - Technical Assessment Guide, Volume 1: Electricity Supply—1993, Revision 7, Electric Power Research Institute, Palo Alto, CA, 1993. EPRI/TR-102276-V1R7.
3. Hollenbacher, R., "Biomass Combustion Technologies in the United States," Proceedings of the Biomass Combustion Conference, Reno, Nevada (January 28-30, 1992).
4. Perry, R.H., and C.H. Chilton, Chemical Engineers' Handbook, Fifth Ed., McGraw-Hill Book Co, New York, NY, 1973.
5. Hansen, J.L., "Fluidized Bed Combustion of Biomass; an Overview," Proceedings of the Biomass Combustion Conference, Reno, Nevada (January 28-30, 1992).
6. "Atmospheric Pressure Fluidized-Bed Boilers" Ch. 16 in Steam, 40th ed., Babcock and Wilcox, Barberton, OH , 1992.
7. "Circulating Fluid Bed Boilers (CFB)," Tampella power, Proceedings of the USA - Finland Executive Seminar on Power Generation and the Environment, Orlando, FL (November 16, 1992).
8. MacCallum, C., "Boiler Design Considerations with Respect to Biomass Ash Deposition," Proceedings of the Biomass Combustion Conference, Reno, Nevada (January 28-30, 1992).
9. Tillman, D., E. Stephens, E. Hughes, and B. Gold "Cofiring Biofuels Under Coal-Fired Boilers: Case Studies and Assessments," Proceedings of Bioenergy '94, Reno, Nevada (October 2-6, 1994).
10. Westerberg, L., "Operation of a Flakt Drying System for Bark and Peat in an Existing Linerboard Mill, " Proceedings of the Fifth International Forest Products Research Society Industrial Wood Energy Forum 81, New Orleans, LA (1981).
11. Ostlie, L.D., "Whole Tree Energy™ Technology and Plot Test Program," Proceedings: Strategic Benefits of Biomass and Waste Fuels, Electric Power Research Institute, Palo Alto, CA, December 1993. Report EPRI/TR-103146.
12. U.S. Department of Energy, Energy Information Agency, Annual Energy Outlook 1997, DOE/EIA-0383(97) , Washington, D.C., 1996.
13. Bain, R.L., and R.P. Overend "Biomass Electric Technologies: Status and Future Development," Advances in Solar Energy: An Annual Review of Research and Development, Vol. 7, edited by K. W. Böer, American Solar Energy Society, Boulder, CO, 1992.
14. Wiltsee, G., N. Korens, D. Wilhelm, "BIOPOWER: Biomass and Waste-Fired Power Plant Performance and Cost Model," Electric Power Research Institute, Palo Alto, CA: May 1996. Report EPRI/TR-102774, Vol. 1.01.

## **DIRECT-FIRED BIOMASS**

15. Marshall and Swift Equipment Cost Index, Chemical Engineering, July 1996.
16. Craig, K.R., and M.K. Mann, Cost and Performance of Biomass-Based Integrated Gasification Combined Cycle Systems, National Renewable Energy Laboratories: January 1996. Report NREL/TP-430-21657.
17. Peters, M.S., and K.L. Timmerhaus, Plant Design and Economics for Chemical Engineers, McGraw-Hill Book Company, New York, NY, 1979. ISBN 0-07-049582-3.
18. Valle-Riestra, J.F., Project Evaluation in the Chemical Products Industry, McGraw-Hill Book Company, New York, NY, 1983. ISBN 0-07-066840-X.

# BIOMASS CO-FIRING

## 1.0 System Description

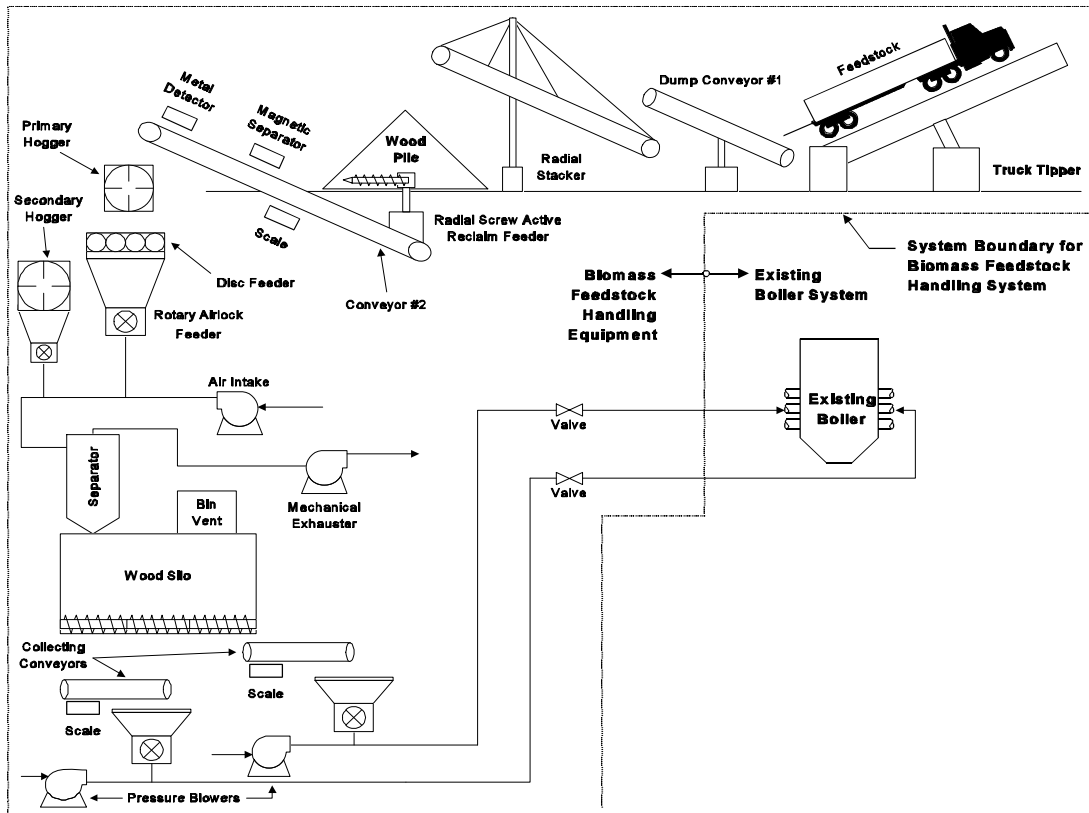

Figure 1. Biomass co-firing retrofit schematic for a pulverized coal boiler system.

Co-firing is the simultaneous combustion of different fuels in the same boiler. Many coal- and oil-fired boilers at power stations have been retrofitted to permit multi-fuel flexibility. Biomass is a well-suited resource for co-firing with coal as an acid rain and greenhouse gas emission control strategy. Co-firing is a fuel-substitution option for *existing* capacity, and is not a capacity *expansion* option. Co-firing utilizing biomass (see Figure 1) has been successfully demonstrated in the full range of coal boiler types, including pulverized coal boilers, cyclones, stokers, and bubbling and circulating fluidized beds [1]. The system described here is specifically for pulverized coal-fired boilers which represent the majority of the current fleet of utility boilers in the U.S.; however, there are also significant opportunities for co-firing with biomass in cyclones. Co-firing biomass in an existing pulverized coal boiler will generally require modifications or additions to fuel handling, storage and feed systems. An automated system capable of processing and storing sufficient biomass fuel in one shift for 24-hour use is needed to allow continuous co-firing while minimizing equipment operator expenses. Typical biomass fuel receiving equipment will include truck scales and hydraulic tippers, however tippers are not required if deliveries are made with self-unloading vans. Biomass supplies may be unloaded and stored in bulk in the coal yard, then reclaimed for processing and combustion. New automated reclaiming equipment may be added, or existing front-end loaders may be detailed for use to manage and reclaim biomass fuel. Conveyors will be added to transport fuel to the processing facility, with magnetic separators to remove spikes, nails, and tramp metal from the feedstock. Since biomass is the “flexible” fuel at these facilities, a 5-day stockpile should be sufficient and will allow avoidance of problems with long-term storage of biomass such as mold development, decomposition, moisture pick-up, freezing, etc. [2].

## BIOMASS CO-FIRING

Fuel processing requirements are dictated by the expected fuel sources, with incoming feedstocks varying from green whole chips up to 5 cm (2 inches) in size (or even larger tree trimmings) to fine dry sawdust requiring no additional processing. In addition to woody residues and crops, biomass fuel sources could include alfalfa stems, switchgrass, rice hulls, rice straw, stone fruit pits, and other materials [3]. For suspension firing in pulverized coal boilers, biomass fuel feedstocks should be reduced to 6.4 mm (0.25 inches) or smaller particle size, with moisture levels under 25% MCW (moisture content, wet basis) when firing in the range of 5% to 15% biomass on a heat input basis [2,4]. Demonstrations have been conducted with feedstock moisture levels as high as 45%. Equipment such as hogs, hammer mills, spike rolls, and disc screens are required to properly size the feedstock. Other boiler types (cyclones, stokers, and fluidized beds) are better suited to handle larger fuel particle sizes. There must also be a biomass buffer storage and a fuel feed and metering system. Biomass is pneumatically conveyed from the storage silo and introduced into the boiler through existing injection ports, typically using the lowest level of burners. Introducing the biomass at the lowest level of burners helps to ensure complete burnout through the scavenging effect of the upper-level burners and the increased residence time in the boiler. Discussions with boiler manufacturers indicate that generally no modifications are required to the burners if the biomass fuel is properly sized [1].

The system described here, and shown in Figure 1, is designed for moderate percentage co-firing (greater than 2% on a heat input basis) and, for that reason, requires a separate feed system for biomass which acts in parallel with the coal feed systems. Existing coal injection ports are modified to allow dedicated biomass injection during the co-firing mode of operation. For low percentage co-firing (less than 2% on a heat input basis), it may be possible to use existing coal pulverizers to process the biomass if spare pulverizer capacity exists. If existing pulverizers are used, the biomass is processed and conveyed to the boiler with the coal supply and introduced into the boiler through the same injection ports as the coal (i.e., the biomass and coal are blended prior to injection into the boiler). Using existing pulverizers could reduce capital costs by allowing the avoided purchase of dedicated biomass processing and handling equipment, but the level of co-firing on a percentage basis will be limited by pulverizer performance, biomass type, and excess pulverizer capacity. The suitability of existing pulverizers to process biomass with coal will vary depending on pulverizer type and biomass type. Attrition mills (pulverizers which operate much like fine hammermills), for example, have more capability to process biomass fuels [3].

Drying equipment has been evaluated by many designers, and recommended by some. Dryers are not included here for three reasons: (1) the benefit-to-cost ratio is almost always low, (2) the industrial fuel sources that supply most co-firing operations provide a moderately dry fuel (between 28% and 6% MCW), and (3) biomass is only a modest percentage of the fuel fired. Although drying equipment is not expected to be included initially, future designs may incorporate cost effective drying techniques (using boiler waste heat) to maintain plant efficiency while firing a broader range of feedstocks with higher moisture contents.

### 2.0 System Application, Benefits, and Impacts

The current fleet of low-cost, coal-fired, base load electricity generators are producing over 50% of the nation's power supply [5]. With the 1990 Clean Air Act Amendments (CAAA) requiring reductions in emissions of acid rain precursors such as sulfur dioxide (SO<sub>2</sub>) and nitrogen oxides (NO<sub>x</sub>) from utility power plants, co-firing biomass at existing coal-fired power plants is viewed as one of many possible compliance options. In addition, co-firing using biomass fuels from sustainably grown, dedicated energy crops is viewed as a possible option for reducing net emissions of carbon dioxide (CO<sub>2</sub>), a greenhouse gas that contributes to global warming. Coupled with the need of the industrial sector to dispose of biomass residues (generally clean wood byproducts or remnants), biomass co-firing offers the potential for solving multiple problems at potentially modest investment costs. These opportunities have caught the interest of power companies in recent years.

## BIOMASS CO-FIRING

Unlike coal, most forms of biomass contain very small amounts of sulfur. Hence, substitution of biomass for coal can result in significant reductions in sulfur dioxide (SO<sub>2</sub>) emissions. The amount of SO<sub>2</sub> reduction depends on the percent of heat obtained from biomass and the sulfur content of the coal. Co-firing biomass with coal can allow power producers to earn SO<sub>2</sub> emission allowances under Section 404(f) of the CAAA [6]. An allowance is earned for each ton of SO<sub>2</sub> emissions reduced (1 allowance = 1 ton = 0.91 tonnes; 1 tonne = 1 metric ton). This section of the CAAA includes provisions for earning credits from SO<sub>2</sub> emissions avoided through energy conservation measures (i.e., demand side management or DSM) and renewable energy. In addition to any allowances which the producer earned by not emitting SO<sub>2</sub>, two allowances can be given to the utility from an allowance reserve for every gigawatt-hour (10<sup>6</sup> kWh) produced by biomass in a co-fired boiler. These allowances may then be sold or traded to others who need them to remain in compliance with the CAAA. The value of an SO<sub>2</sub> allowance has ranged from \$135 in 1993 to a current value of about \$80.

As with fossil fuels, a result of burning biomass is the emission of CO<sub>2</sub>. However, biomass *absorbs* about the same amount of carbon dioxide during its growing cycle as is emitted from a boiler when it is burned. Hence, when biomass production is undertaken on a sustainable or “closed-loop” basis by raising energy crops or by using the standard practice in the U.S. of growing at least as much forest as is being harvested, *net* CO<sub>2</sub> emissions on a complete fuel cycle basis (from growth to combustion) are considered to be nearly zero [7]. Therefore, biomass co-firing may be one of the most practical strategic options for complying with restrictions on generation of greenhouse gases. Fossil CO<sub>2</sub> reductions are currently being pursued voluntarily by utilities in the U.S. through the federal government’s Climate Challenge program. These utilities may be able to receive early credit for their fossil CO<sub>2</sub> emission reductions for future use in the event that legislation is passed which creates market value for CO<sub>2</sub> reductions. Total estimated emissions of both SO<sub>2</sub> and CO<sub>2</sub> from power plants operating in coal-only modes and when co-firing with biomass are shown in Table 3 (Section 4.2).

In addition to these emissions reductions and being a *base load* renewable power option, biomass co-firing has other possible benefits. The use of biomass to produce electricity in a dedicated feedstock supply system, where biomass is grown specifically for the purpose of providing a fuel feedstock, will provide new revenue sources to the U.S. agriculture industry by providing a new market for farm production. These benefits will result in substantial positive economic effects on rural America. Using urban wood residues as a fuel reduces landfill material and subsequently extends landfill life. For industries served by the utilities, rising costs of tipping fees, restrictions on landfill use, and potential liabilities associated with landfill use represent opportunities for power companies to assist industrial customers while obtaining low-cost biomass residues for use as alternative fuels. These residues can be mixed with more expensive biomass from energy crops to reduce the overall cost of biomass feedstocks. Finally, firing biomass in boilers with pollution control can reduce burning of wood residues in uncontrolled furnaces or in open fields, and hence provides another means of reducing air emissions.

Potential negative impacts associated with co-firing biomass fuels include: (1) the possibility for increased slagging and fouling on boiler surfaces when firing high-alkali herbaceous biomass fuels such as switchgrass, and (2) the potential for reduced fly ash marketability due to concerns that commingled biomass and coal ash will not meet existing ASTM fly ash standards for concrete admixtures, a valuable fly ash market. These two issues are the subject of continued research and investigation. Two factors indicate that biomass co-firing (using sources of biomass such as energy crops or residues from untreated wood) will have a negligible effect on the physical properties of coal fly ash. First, the mass of biomass relative to coal is small for co-firing applications, since biomass provides 15% or less of the heat input to the boiler. Second, combustion of most forms of biomass results in only half as much ash when compared to coal. Despite these factors, significant efforts will be required to ensure that commingled biomass and coal ash will meet ASTM standards for concrete admixture applications. In the immediate future (three to five years), the ASTM standards that preclude the use of non-coal ash will probably remain unchanged. Estimated ash effluents are shown in Table 3 (Section 4.2) for power plants operating in the coal-only mode and when co-firing with biomass.

## BIOMASS CO-FIRING

### 3.0 Technology Assumptions and Issues

Biomass co-firing is a retrofit application, primarily for coal-fired power plants. Biomass co-firing is applicable to most coal-fired boilers used for power generation. A partial list of existing or planned utility applications is shown in Table 1. Retrofits to co-fire at 5% (by heat) or more for coal-fired cyclones, stokers, and fluidized bed boilers are potentially simpler and less expensive than for pulverized coal. However, pulverized coal boilers are the most widely used steam generating system for coal-fired power generation in the U.S., and they represent the majority of plants affected by 1990 Clean Air Act Amendment provisions for reducing the emissions of SO<sub>2</sub> and NO<sub>x</sub> from electric generating units.

The power plants characterized in the following section are pulverized coal plants which co-fire from 10% to 15% biomass on a heat input basis. The co-firing rate is not projected to exceed 15% due to biomass resource limitations and requirements to maintain unit efficiency. System capital and operating costs are assumed to be representative of plants which receive biomass via self-unloading vans and can utilize existing front-end loaders for receiving and pile management. The facilities are assumed to be located in a region where medium- to high-sulfur coal (0.8% by weight and greater) is used as a utility boiler fuel and where biomass residues are available for relatively low costs (\$0.47/GJ, or \$0.50/MMBtu; 1 MMBtu = 10<sup>6</sup> Btu). Areas with these characteristics include portions of the Northeast, Southeast, mid-Atlantic, and Midwest regions.

As shown in Table 1, biomass co-firing with coal is currently practiced at a handful of utility-scale boilers (Northern States Power, Tacoma Public Utilities, New York State Electric and Gas, TVA). Co-firing has also been successfully demonstrated by GPU Genco, Madison Gas & Electric, Southern Company, and several others. Retrofits require commercially available fuel handling and boiler equipment. Optimized equipment for efficiently processing some biomass feedstocks (such as switchgrass and willow energy crops) to a size suitable for combustion in a pulverized coal boiler will require further development and demonstration. Engineering and design issues are well understood for most applications, but the optimum design for a given power plant will be site-specific and could vary depending on a number of key factors, including site layout, boiler type, biomass type and moisture content, level of co-firing, type of existing pulverizer, and pulverizer excess capacity. In general, capital costs for blended feed systems are low (about \$50/biomass kW) and costs for separate feed systems are higher (about \$200/biomass kW). The design shown in this technology characterization is a separate feed system. Separate feeding is needed for biomass heat contributions greater than 2% to 5% in a pulverized-coal boiler. At low co-firing levels in a pulverized-coal unit (<2%), or at mid-level (5% to 10%) in a cyclone, blended feed can be used.

Emissions of gaseous effluents other than CO<sub>2</sub> and SO<sub>2</sub> are not estimated in Section 4 because they are highly dependent on boiler operating conditions and design. However, NO<sub>x</sub> emissions for a co-fired boiler could be lower than those for a 100% coal-fired boiler due to the lower nitrogen content of biomass and the lower flame temperatures associated with combustion of high-moisture-content biomass feedstocks. In addition, reburn technologies using biomass could provide additional NO<sub>x</sub> reductions. Reburning involves a fuel-lean primary combustion stage, followed by the downstream injection of an additional fuel (natural gas, or micronized coal or biomass) in a fuel-rich secondary zone (the reburn zone) to reduce the NO<sub>x</sub> formed in the primary stage. Additional air is injected downstream of the fuel-rich zone to complete combustion. Further research and development in the area of NO<sub>x</sub> reduction, for both reburn and conventional co-firing arrangements, is required to better define the potential NO<sub>x</sub> reduction benefits associated with biomass co-firing. If the NO<sub>x</sub> reduction benefits using biomass are proven to be

## BIOMASS CO-FIRING

Table 1. Previous, existing, or planned biomass co-firing applications [1].

Utility, Plant Name, Location	Co-fired Fuels	Total (Net) Plant Size *	Boiler Technology
Northern States Power Allen S. King Station Minneapolis, Minnesota	Coal/wood residues (lumber)	560 MW <sub>e</sub>	Cyclone
Otter Tail Power Co. Big Stone City, South Dakota	Coal/refuse-derived-fuel (RDF)/tires/waste oil/ag. refuse	440 MW <sub>e</sub>	Cyclone
Tennessee Valley Authority Allen Fossil Plant Memphis, Tennessee	Coal/wood residues and coal/wood/tires	272 MW <sub>e</sub>	Cyclone
I/S Midtkraft Energy Co. Grenaa Co-Generation Plant Grenaa, Denmark	Coal/straw	150 MW <sub>e</sub>	Circulating Fluidized Bed
Tacoma Public Utilities -- Light Division Steam Plant No. 2 Tacoma, Washington	Coal/RDF/wood residues	2 x 25 MW <sub>e</sub>	Bubbling Fluidized Bed
GPU Genco Shawville Station Johnstown, Pennsylvania	Coal/wood residues	130 MW <sub>e</sub> and 190 MW <sub>e</sub>	Pulverized Coal
IES Utilities Inc. Sixth Street (1) and Ottumwa (2) Stations Marshalltown, Iowa	(1) Coal/agricultural residues (2) Coal/switchgrass	(1) 3 Units, 6-15 MW <sub>e</sub> (2) 714 MW <sub>e</sub>	(1) Pulverized Coal (2) Pulverized Coal
Madison Gas & Electric Blount Street Station Madison, Wisconsin	Coal/switchgrass	50 MW <sub>e</sub>	Pulverized Coal
New York State Electric & Gas Greenidge Station Dresden, New York	Coal/wood residues and coal/energy crops (willow)	108 MW <sub>e</sub>	Pulverized Coal
Niagara Mohawk Power Corp. Dunkirk Station Dunkirk, New York	Coal/wood residues and coal/energy crops (willow)	91 MW <sub>e</sub>	Pulverized Coal
Tennessee Valley Authority (1) Kingston and (2) Colbert Fossil Plants (1) Kingston, TN and (2) Tuscumbia, AL	(1) Coal/wood residues (2) Coal/wood residues	(1) 190 MW <sub>e</sub> (2) 190 MW <sub>e</sub>	(1) Pulverized Coal (2) Pulverized Coal
EPON Centrale Gelderland Netherlands	Coal/wood residues (demolition)	602 MW <sub>e</sub>	Pulverized Coal
I/S Midtkraft Energy Co. Studstrupvaeket, Denmark	Coal/straw	150 MW <sub>e</sub>	Pulverized Coal
Uppsala Energi AB Uppsala, Sweden	Coal (peat)/ wood chips	200 MW <sub>e</sub> and 320 MW <sub>t</sub>	Pulverized Coal
New York State Electric & Gas Hickling (1) and Jennison (2) Stations Big Flats and Bainbridge, New York	Coal/wood residues and coal/tires	(1) 37.5 MW <sub>e</sub> (2) 37.5 MW <sub>e</sub>	(1) Stoker (2) Stoker
Northern States Power Bay Front Station Ashland, Wisconsin	Coal/wood residues (forest)	2 x 17 MW <sub>e</sub>	Stoker

Notes:

\* The capacity supported by the supplementary (i.e., biomass) fuel will be a fraction of the total capacity shown in this table, normally in the range of 1 to 10% of the total capacity.



## BIOMASS CO-FIRING

feasible for reducing the NO<sub>x</sub> emissions control costs at existing cyclone and pulverized coal boilers, the resulting cost savings could be several times the fuel savings for co-firing [8]. The dollar value of NO<sub>x</sub> reduction will be site-specific, depending on the cost of the alternative NO<sub>x</sub> control action.

As mentioned in Section 2, two other issues needing additional research and development efforts are: (1) slagging and fouling on boiler surfaces caused by firing high alkali herbaceous biomass feedstocks such as switchgrass, and (2) the potential for reduced fly ash marketability due to concerns that commingled biomass and coal ash will not meet ASTM fly ash standards for concrete admixtures. Finally, due to high transportation costs, sufficiently inexpensive biomass residues and energy crops (relative to local coal prices) must exist within an 80 to 120 km (50 to 75 mile) radius to economically justify a co-firing operation [9]. Improved resource acquisition methods and energy crop development are needed to foster the widespread adoption of biomass co-firing.

### 4.0 Performance and Cost

Table 2 summarizes the performance and cost indicators for the biomass co-fired system being characterized in this report.

#### 4.1 Evolution Overview

In the tables in this section, for each year from 1997 through 2030, the performance of two systems is estimated. One is a pulverized coal power plant using only coal. These cases represent the plant operation prior to a biomass co-firing retrofit. The other case shows the performance of the same power plant operating with biomass co-firing. The 1997 base case is a 100 MW plant which obtains 10% of its total heat input from biomass while in the co-firing mode, resulting in 10 MW of biomass-based power generation capacity. This is representative of the planned size and co-firing rates of two Northeast power plants that are presently participating in the DOE Salix Consortium demonstration project. The same size boiler is used for the year 2000 case, but the co-firing rate is increased from 10% to 15%, assuming that lessons learned during initial years will permit sustained operation in similar boilers at a 15% co-firing rate. This case results in 15 MW of biomass-based generation capacity. Co-firing rates as high as 15% have been demonstrated during preliminary testing. For the years 2005 through 2030, co-firing rates remain the same (15%), but boiler sizes are increased from year to year. This demonstrates the effect that improved biomass feedstock acquisition techniques and increased development of energy crops will have in allowing increasingly larger power plants to be co-fired near maximum levels of 15%.

#### 4.2 Performance and Cost Discussion

The tools used for this analysis were based on EPRI's BIOPOWER co-firing model [10]. Input requirements for the model include ultimate analyses of the fuels (chemical composition of the fuels), capacity factor for the power plant, net station capacity, gross turbine heat rate, and percent excess air at which the plant operates. The technical input information used for the model was based on data from a representative Northeast power plant which intends to implement biomass co-firing [2]. For a given biomass co-firing rate, the model calculates thermal efficiency, change in net heat rate, coal and biomass consumption, and reduced SO<sub>2</sub> and CO<sub>2</sub> emissions.

The coal was assumed to contain 1.9% sulfur, compared to a 0.02% sulfur content for the biomass. Moisture contents were 7.2% for the coal and 21.5% for the biomass. Ash contents were assumed to be 8.8% for coal and 0.9% for

Table 2. Performance and cost indicators.

INDICATOR NAME	UNITS	Base Case		2000		2005		2010		2020		2030	
		1997	+/- %		+/- %		+/- %		+/- %		+/- %		+/- %
Plant Size	MW	100		100		150		200		300		400	
General Performance Indicators													
Capacity Factor	%	85		85		85		85		85		85	
Coal Moisture Content	%	7.2		7.2		7.2		7.2		7.2		7.2	
Biomass Moisture Content	%	21.5		21.5		21.5		21.5		21.5		21.5	
Annual Energy Delivery	GWh/yr	745		745		1,117		1,489		2,234		2,978	
Coal-only Performance Indicators													
Efficiency	%	32.9		32.9		32.9		32.9		32.9		32.9	
Net Heat Rate	kJ/kWh	10,929		10,929		10,929		10,929		10,929		10,929	
Net Power Capacity from Coal	MW	100		100		150		200		300		400	
Annual Electricity Delivery from Coal	GWh/yr	745		745		1,117		1,489		2,234		2,978	
Coal Consumption	tonnes/yr	276,175		276,175		414,262		552,350		828,525		1,104,699	
Annual Heat Input from Coal @ 31,751 kJ/kg	TJ/yr	8,138		8,138		12,206		16,275		24,413		32,550	
TOTAL Annual Heat Input	TJ/yr	8,138		8,138		12,206		16,275		24,413		32,550	
Biomass Co-firing Performance Indicators													
Co-firing Rate (Heat Input from Biomass)	%	10		15		15		15		15		15	
Thermal Efficiency	%	32.7		32.5		32.5		32.5		32.5		32.5	
Net Heat Rate	kJ/kWh	11,015		11,066		11,066		11,066		11,066		11,066	
Net Power Capacity from Coal	MW	90		85		128		170		255		340	
Net Power Capacity from Biomass	MW	10.0		15.0		22.5		30.0		45.0		60.0	
Annual Electricity Delivery from Coal	GWh/yr	670		633		949		1,266		1,899		2,532	
Annual Electricity Delivery from Biomass	GWh/yr	74		112		168		223		335		447	
Coal Consumption	tonnes/yr	250,525		237,695		356,542		475,389		713,084		950,778	
Biomass Consumption (dry)	tonnes/yr	42,933		64,695		97,043		129,391		194,086		258,781	
Annual Heat Input from Coal @ 31,751 kJ/kg	TJ/yr	7,382		7,004		10,506		14,007		21,011		28,015	
Annual Heat Input from Biomass @ 19,104 kJ/kg	TJ/yr	820		1,236		1,854		2,472		3,708		4,944	
TOTAL Annual Heat Input	TJ/yr	8,202		8,240		12,359		16,479		24,719		32,959	

NOTES:

1. The columns for "+/- %" refer to the uncertainty associated with a given estimate

Table 2. Performance and cost indicators. (cont.)

INDICATOR NAME	UNITS	Base Case		2000		2005		2010		2020		2030	
		1997	+/- %		+/- %		+/- %		+/- %		+/- %		+/- %
Plant Size	MW	100		100		150		200		300		400	
Capital Cost (\$/kW of BIOMASS power capacity)													
Biomass Handling System Equipment	\$/kW		25		25		25		25		25		25
Conveyor		12.9		12.1		11.4		10.9		10.3		9.9	
Separation Equipment, Conveyor		3.5		3.3		3.1		3.0		2.8		2.7	
Hogging Tower and Equipment		21.3		20.0		18.9		18.1		17.0		16.3	
Pneumatic Conveying System (Vacuum)		4.5		4.2		4.0		3.8		3.6		3.4	
Wood Silo with Live Bottom		5.5		5.2		4.9		4.7		4.4		4.2	
Collecting Conveyors		6.6		6.2		5.8		5.6		5.3		5.0	
Rotary Airlock Feeders		0.6		0.6		0.5		0.5		0.5		0.5	
Pneumatic Conveying System (Pressure)		17.0		16.0		15.1		14.4		13.6		13.0	
Controls		10.5		9.9		9.3		8.9		8.4		8.0	
Total Equipment		82.4		77.5		73.0		69.9		65.8		63.0	
Biomass Handling System Installation		51.2	25	48.2	25	45.3	25	43.4	25	40.9	25	39.1	25
Total Biomass Handling		133.6		125.7		118.3		113.3		106.6		102.1	
Civil Structural Work		36.9	25	34.7	25	32.7	25	31.3	25	29.4	25	28.2	25
Modifications at Burners		3.0	15	2.8	15	2.7	15	2.5	15	2.4	15	2.3	15
Electrical		16.4	25	15.4	25	14.5	25	13.9	25	13.1	25	12.5	25
Subtotal (A)		189.9		178.7		168.2		161.0		151.5		145.1	
Contingency @ 30%, 0.3 * (A)		57.0		53.6		50.4		48.3		45.5		43.6	
Total Direct Costs (B)		246.9		232.3		218.6		209.3		197.0		188.7	
Engineering @ 10%, 0.1 * (B)		24.7		23.2		21.9		20.9		19.7		18.9	
Total Capital Requirement		271.6		255.5		240.5		230.3		216.7		207.6	

NOTES:

1. The columns for "+/- %" refer to the uncertainty associated with a given estimate
2. Plant construction is assumed to require 1 year for a retrofit to an existing system

Table 2. Performance and cost indicators. (cont.)

INDICATOR NAME	UNITS	Base Case		2000		2005		2010		2020		2030	
		1997	+/- %		+/- %		+/- %		+/- %		+/- %		+/- %
Plant Size	MW	100		100		150		200		300		400	
<i>Incremental Operation and Maintenance Costs; Incremental O&amp;M = Biomass O&amp;M - Coal O&amp;M ; Values in ( ) indicate negative costs (i.e., revenues).</i>													
Fuel Cost @ \$9.14/dry tonne (biomass) *	¢/kWh	(.820)		(.817)		(.817)		(.817)		(.817)		(.817)	
Fuel Cost @ \$51.48/dry tonne (biomass) *	¢/kWh	1.622		1.635		1.635		1.635		1.635		1.635	
Fuel Cost @ \$9.14/dry tonne (biomass) †	¢/kWh	(.439)		(.437)		(.437)		(.437)		(.437)		(.437)	
Fuel Cost @ \$51.48/dry tonne (biomass) †	¢/kWh	2.002		2.016		2.016		2.016		2.016		2.016	
Variable Costs	¢/kWh												
Consumables (incl. SO <sub>2</sub> credit revenue) ‡		(.163)		(.163)		(.163)		(.163)		(.163)		(.163)	
Fixed Costs	\$/kW-yr												
Labor		5.00		5.00		5.00		5.00		5.00		5.00	
Maintenance		5.43		5.11		4.81		4.61		4.33		4.15	
Total Fixed Costs		10.43		10.11		9.81		9.61		9.33		9.15	
<b>Total Operating Costs</b>													
@ \$9.14/dry tonne (biomass) *	¢/kWh	(.842)		(.844)		(.848)		(.851)		(.855)		(.857)	
@ \$51.48/dry tonne (biomass) *	¢/kWh	1.599		1.608		1.604		1.601		1.598		1.595	
@ \$9.14/dry tonne (biomass) †	¢/kWh	(.462)		(.464)		(.468)		(.470)		(.474)		(.477)	
@ \$51.48/dry tonne (biomass) †	¢/kWh	1.980		1.989		1.985		1.982		1.978		1.976	

NOTES:

1. The columns for "+/- %" refer to the uncertainty associated with a given estimate

2. Plant construction is assumed to require 1 year for a retrofit to an existing system

\* Coal cost is assumed to be \$39.09/tonne

† Coal cost is assumed to be \$28.05/tonne

‡ SO<sub>2</sub> credit revenues are calculated as follows, with SO<sub>2</sub> credits valued at \$110/tonne SO<sub>2</sub> = \$100/ton SO<sub>2</sub>:

$[(\text{Coal-only} - \text{Co-firing}) \text{ tonnes SO}_2/\text{yr} * (1 \text{ allowance/tonne SO}_2) + (2 \text{ allowances/GWh biomass power}) * (\text{GWh biomass power/yr})] *$

$(\$110/\text{allowance}) * (100 \text{ ¢/\$}) / (\text{kWh biomass power/yr})$

Projected annual SO<sub>2</sub> savings for each year from 1997 to 2030 are \$121,100, \$181,600, \$272,500, \$363,100, \$544,700, and \$726,300, respectively.

## BIOMASS CO-FIRING

biomass. The coal heating value was 31,751 kJ/kg (13,680 Btu/lb) (dry), while that for the biomass was 19,104 kJ/kg (8,231 Btu/lb) (dry). These values for sulfur, moisture, ash, and heating value were taken directly from tests conducted on the fuel supplies for the representative power plant. They are typical for eastern bituminous coal and hardwood biomass [11,12]. According to plant records, the gross turbine heat rate is 9,118 kJ/kWh (8,643 Btu/kWh). A capacity factor of 85% was used, based on historical records at the plant and projected future needs. The resulting estimate net heat rate for coal-only operation is 10,929 kJ/kWh (10,359 Btu/kWh). This value is typical of high capacity factor coal boilers in the range from 100 MW to 400 MW, and was therefore assumed constant for all cases. Improvements in net plant heat rate for future coal plants were not considered in this analysis. The material and energy balances for the year 2000 case are shown in Figure 2.

All system capital costs are due to the retrofit of an existing pulverized coal boiler to co-fire biomass. Costs for the 1997 case are based on engineering specifications, including materials and sizing of major system components, from a feasibility study for a corresponding 10 MW (biomass power) biomass co-firing retrofit at an existing plant [2]. The unit costs for the co-firing retrofit are expressed in \$/kW of biomass power capacity, not total power capacity. For each following year, unit costs for larger co-firing systems were scaled down based on the relationship [13]:  $\text{Cost}(B) = \text{Cost}(A) * [\text{MW}(B) / \text{MW}(A)]^s$ , where the scaling factor "s" was assumed to be 0.9. The effect of this scaling relationship is a 10% reduction in \$/kW unit costs for a doubling in system capacity (MW). This corresponds to observed economies of scale for coal power plants [14]. Since the system components are already commercially available and no major technological advances are expected, the only reductions in unit capital costs assumed to occur are due to economies of scale, not technological advancements or increased equipment production volumes.

Capital costs include costs for new equipment (e.g., fuel handling), boiler modifications, controls, engineering fees (10% of total process capital), civil/structural work including foundations and roadways, and a 30% contingency [2]. Cost estimates for the example systems assume that front-end loaders and truck scales are already available at the plant for unloading and pile management. Costs also assume that live-bottom trucks are used for biomass delivery, allowing the avoidance of the purchase of a truck tipper. Land and substation (system interface) costs are zero because existing plant property and the existing substation will be utilized.

Operation and maintenance costs, including fuel costs, are presented in Table 2 on an *incremental* basis. That is, each O&M cost component listed there represents the *difference* in that cost component when comparing biomass co-firing operation to coal-only operation. Negative costs, surrounded by parentheses in the table, represent a cost saving in the co-firing operation relative to coal-only operation. Fixed operating costs are broken into two components, labor and maintenance. Estimates of both of these cost components are based on information obtained from plant management at an existing co-firing operation [2]. Fixed labor costs are estimated based on a requirement for one additional operator for each 10 MW of biomass capacity (0.1 operator/MW). The operator manages the biomass deliveries, handling and processing equipment, and is compensated at a loaded rate of \$50,000 per year. Annual fixed maintenance costs are assumed to be 2% of the original capital cost of the co-firing retrofit [15]. Variable operation costs (consumables such as water, chemicals, etc.) are assumed to be the same for co-firing operation and coal-only operation, with the exception of the assumed value received for reduced SO<sub>2</sub> emissions. The assumed value of an SO<sub>2</sub> allowance is \$100/ton SO<sub>2</sub> reduced (\$110/tonne) and the value is assumed to remain constant throughout the analysis period. It is also assumed that fossil-based CO<sub>2</sub> emissions savings hold zero financial value; however, this is subject to change and could have a large impact on the economics of a co-firing application.

It should be recognized that co-firing retrofit costs are extremely site-specific and can range from \$50 to \$700/kW [2,4] depending on many factors, including boiler type, amount of biomass co-fired, site layout, existing receiving equipment at the plant, complexity of handling and processing system design, nature of the biomass feedstock, etc. The example used in the present analysis provides a payback period of about three to four years (a typical

## BIOMASS CO-FIRING

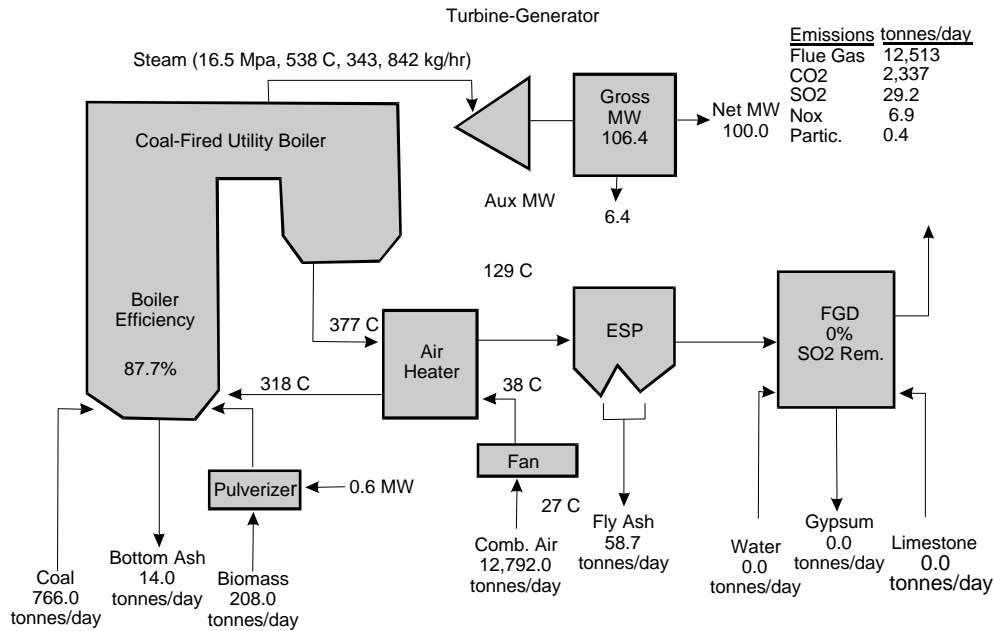

<b>Energy Balance (GJ/hr)</b>	Baseline	Alt. Fuel	<b>Material Balance (Mg/hr)</b>	Baseline	Alt. Fuel
	<u>Coal Only</u>	<u>Cofired</u>		<u>Coal Only</u>	<u>Cofired</u>
<u>Heat In</u>					
Coal	1092.9	940.6	Coal	37.1	31.9
Wood Blend	-----	166.0	Residues		11.1
Total	1092.9	1106.6	Limestone	0.0	0.0
<u>Heat Out</u>					
Net steam turbine output	360.1	360.1	FGD Water Makeup	0.0	0.0
Auxiliary power use	23.0	23.0	Combustion air	525.3	533.0
Condenser	587.0	587.0	Total	562.4	576.0
Stack gas losses	97.6	112.1	<u>Mass Out</u>		
Boiler radiation losses	3.4	3.4	Bottom ash	0.7	0.6
Unburned carbon losses	5.5	4.4	Fly ash	2.8	2.4
Unaccounted for boiler heat loss	16.4	16.6	Gypsum	0.0	0.0
Total	1092.9	1106.6	Flue gas	558.9	573.0
			Total	562.4	576.0
<b>Plant Performance</b>			<b>Annual Performance</b>		
Net Capacity, MW	100.0	100.0	Capacity Factor, %	85.0	85.0
Boiler Efficiency, %	88.8	87.7	Coal, 1000 tonnes/yr	276.2	237.7
Net Heat Rate, kJ/kWh	10,929	11,066	Alt. Fuel, 1000 tonnes/yr		64.7
Thermal Efficiency, %	32.9	32.5			
Capacity Factor, %	85.0	85.0			

Figure 2. Material and energy balances for 100 MW (Nameplate) boiler at 15% biomass co-firing (see year 2000 case) [10]. Moisture contents were 7.2% for the coal and 21.5% for the biomass.

## BIOMASS CO-FIRING

requirement for capital expenditures by plant managers)--i.e., it represents a realistic installation under present economic conditions--assuming a biomass residue supply is available for \$9.14/dry tonne (\$8.29/dry ton, \$0.50/MMBtu) and coal costs at the plant are \$39.09/tonne (\$35.46/ton, \$1.40/MMBtu). The economics are less favorable for coal costs less than \$39.09/tonne, especially in areas of the Midwest where prices are as low as \$28.05/tonne (\$1.00/MMBtu). More expensive systems which do not provide a similar payback will likely not be implemented unless the capital expenditure decisions are heavily influenced by other factors such as providing service to a valuable customer, or achieving emissions reductions. To demonstrate the effect of various biomass and coal prices on overall *incremental* operation and maintenance costs, three more fuel price scenarios are shown in Table 2. The fuel price scenarios are:

1. \$9.14/dry tonne (\$8.29/dry ton, \$0.50/MMBtu) biomass costs and \$39.09/tonne (\$35.46/ton, \$1.40/MMBtu) coal costs--This represents an economic scenario where abundant sources of biomass residues are available at a cheap price, while coal prices are near the national average. The resulting simple payback periods range from 4.3 years for the 1997 base case to 3.3 years in 2030. Under these financial circumstances, a biomass co-firing retrofit is marginally economical with no additional environmental subsidies. An environmental credit equivalent to \$3.31/tonne (\$3.00/ton) of reduced fossil CO<sub>2</sub> emissions would result in a three year simple payback period for the year 2000 case.
2. \$51.48/dry tonne (\$46.70/dry ton, \$2.84/MMBtu) biomass costs and \$39.09/tonne (\$35.46/ton, \$1.40/MMBtu) coal costs--This represents an economic scenario where energy crops are the biomass fuel and coal prices are near the national average. Under these financial circumstances, a co-firing retrofit will not pay off without additional environmental subsidies. An environmental credit equivalent to \$31.42/tonne (\$28.50/ton) of reduced fossil CO<sub>2</sub> emissions would be necessary to obtain a three year simple payback period for the year 2000 case.
3. \$9.14/dry tonne (\$8.29/dry ton, \$0.50/MMBtu) biomass costs and \$28.05/tonne (\$25.45/ton, \$1.00/MMBtu) coal costs--This represents an economic scenario where abundant sources of biomass residues are available at a cheap price while coal prices are low. The resulting simple payback periods range from 7.9 years for the 1997 base case to 5.8 years in 2030. Under these financial circumstances, a co-firing retrofit will not pay off without additional environmental subsidies. An environmental credit equivalent to \$7.72/tonne (\$7.00/ton) of reduced fossil CO<sub>2</sub> emissions would be needed to achieve a three year simple payback period for the year 2000 case.
4. \$51.48/dry tonne (\$46.70/dry ton, \$2.84/MMBtu) biomass costs and \$28.05/tonne (\$25.45/ton, \$1.00/MMBtu) coal costs--This represents an economic scenario where energy crops are the biomass fuel and coal prices are low. Under these financial circumstances, a co-firing retrofit will not pay off without additional environmental subsidies. An environmental credit equivalent to \$35.82/tonne (\$32.50/ton) of reduced fossil CO<sub>2</sub> emissions would be needed to achieve a three year simple payback period for the year 2000 case.

It should be noted that cheaper alternatives for biomass co-firing exist. While high percentage co-firing in pulverized coal boilers represents a large potential market, it is also one of the most expensive co-firing arrangements. In the near term, less costly alternatives such as low percentage co-firing in pulverized coal boilers, low- or mid-percentage co-firing in cyclone boilers, or co-firing in stoker or fluidized bed boilers may be more attractive. Capital costs for these options could be less than \$50/kW of biomass power capacity. At a capital cost of \$100/kW of biomass power capacity, the fuel price scenarios described in cases 1 and 3 above would result in simple payback periods of 1.5 and 2.7 years, respectively, without additional environmental credits.

For each fuel cost scenario, biomass costs are assumed to remain constant (in 1997 dollars) in future years. The 100% residue scenario (#1 from above) is a likely one for the early years of a co-firing retrofit since, in the absence of greater monetary values for SO<sub>2</sub> (and CO<sub>2</sub>) emissions reductions, a cheap source of residue fuel will be required to return the capital investment in an acceptable period of time (three years or less). A more dependable--but likely more expensive--feedstock in future years may be provided by dedicated energy crops. Once the capital costs have been paid off by

## BIOMASS CO-FIRING

fuel cost savings gained from using cheap residues in the initial years, feedstocks from dedicated energy crops may be combined with the remaining available cheap residues.

Coal costs are assumed to remain constant (in 1997 dollars) through future years based on projected stable coal prices [5]. The base year price of \$39.09/tonne (\$35.46/ton) is near or less than the 1995 average delivered coal price for the following census regions: New England, Middle Atlantic, East North Central, South Atlantic, West South Central, and Pacific Contiguous [16].

It should be recognized that, in a competitive restructured power industry, a major advantage of co-firing is fuel diversification. Plant management will use the fuel mix which will provide the overall lowest production costs once all fuel prices, O&M costs, environmental credits, and tax benefits are considered.

Effluent estimates (see Table 3) were derived using ultimate analyses and material balances (material and energy balances for the year 2000 case were provided in Figure 2). In Table 3, effluent estimates are shown for each year for coal-only operation, co-fired operation, and net reductions due to co-firing. Sulfur dioxide emissions, fossil fuel based carbon dioxide emissions, and ash discharges are all reduced by co-firing. Total estimated emissions of CO<sub>2</sub> from the stack show an increase when co-firing (due partially to the increased net heat rate when co-firing); however, if energy crops are used as the fuel source, the net CO<sub>2</sub> emissions on a full fuel cycle basis will be decreased due to the absorption of CO<sub>2</sub> from the atmosphere by the crops during their growth.

### 5.0 Land, Water, and Critical Materials Requirements

Resource requirements are shown in Table 4. It is important to note that in a typical co-firing application, no additional expenditures for land would be incurred. Available on-site coal storage areas can be managed to accommodate the biomass, and the space occupied by handling and processing equipment for biomass is easily provided on the existing property.

Land: The land area required for this co-firing example includes the area required for fuel storage plus the area needed to house the biomass processing and handling equipment. In a typical co-firing application, this newly required space can be found on the existing site of the power plant, and no additional land costs are incurred by the power producer. This is one example of the site-specific nature of a co-firing retrofit. The biomass storage, handling, and processing system will need to be designed to perform efficiently while also fitting within available space without negatively impacting existing operations at the facility. Additional land will be required for growing biomass to replace that used at the power plant. The estimated land requirements for growing biomass are also shown in Table 4, along with the average annual yields (dry tons/acre) used for the calculations for each year.

Because biomass has a lower energy density than coal, it will occupy a larger land area. The bulk volume (dry basis) of sawdust is about 6.2 m<sup>3</sup>/MT (200 ft<sup>3</sup>/ton) while an average value for bituminous coal is about 1.3 m<sup>3</sup>/MT (42 ft<sup>3</sup>/ton) [11]. Combined with the estimated heating values of the fuels, 19,104 kJ/kg (8,231 Btu/lb) for biomass and 31,751 kJ/kg (13,680 Btu/lb) for coal, biomass occupies 0.33 m<sup>3</sup>/GJ (12 ft<sup>3</sup>/MMBtu) while coal only occupies 0.04 m<sup>3</sup>/GJ (1.5 ft<sup>3</sup>/MMBtu); i.e., the biomass (sawdust) in this example occupies about eight times as much volume as coal for the same amount of heat. The resulting *additional* land area required for storage of biomass, assuming a 5-day supply is maintained on-site in a 6 m (20 ft) high pile, is shown in Table 4. This number assumes that biomass supplies will be handled in a similar manner to the present supply of coal at the facility; i.e., by bulldozers and front end loaders, placed in a single pile approximately 6 m (20 ft) high.



## BIOMASS CO-FIRING

Table 3. Gaseous, liquid\*, and solid effluents. (Values in this table, for each year, correspond to conditions described in Table 2.)

Indicator Name	Units	Base Year 1997	Future				
			2000	2005	2010	2020	2030
Plant Size	MW	100	100	150	200	300	400
Annual Electricity Generation	GWh/yr	745	745	1,117	1,489	2,234	2,978
<b>Coal-Only System:</b>							
Gaseous Emissions							
SO <sub>2</sub>	tonnes/yr	10,500	10,500	15,700	21,000	31,500	41,900
Fossil CO <sub>2</sub>	tonnes/yr	705,800	705,800	1,058,800	1,411,700	2,117,500	2,823,400
Solid Effluents							
Bottom Ash	tonnes/yr	4,900	4,900	7,300	9,700	14,600	19,400
Fly Ash	tonnes/yr	20,600	20,600	30,900	41,200	61,700	82,300
<b>Co-Firing System:</b>							
Co-Firing Rate (Heat obtained from biomass)	% of total	10	15	15	15	15	15
Gaseous Emissions							
SO <sub>2</sub>	tonnes/yr	9,500	9,100	13,600	18,100	27,200	36,200
Stack CO <sub>2</sub> (Fossil + Biomass)	tonnes/yr	718,600	725,000	1,087,600	1,450,100	2,175,100	2,900,200
Fossil CO <sub>2</sub>	tonnes/yr	640,300	607,500	911,300	1,215,000	1,822,500	2,430,000
Solid Effluents							
Bottom Ash	tonnes/yr	4,500	4,300	6,500	8,700	13,000	17,300
Fly Ash	tonnes/yr	18,900	18,200	27,400	36,500	54,700	72,900
<b>Co-Firing System Savings vs. Coal-Only:</b>							
Gaseous Emissions							
SO <sub>2</sub>	tonnes/yr	950	1,400	2,100	2,900	4,300	5,700
Stack CO <sub>2</sub> (Fossil + Biomass)	tonnes/yr	(12,700)	(19,200)	(28,800)	(38,400)	(57,600)	(76,800)
Fossil CO <sub>2</sub>	tonnes/yr	65,600	98,300	147,500	196,700	295,000	393,400
Solid Effluents							
Bottom Ash	tonnes/yr	350	500	790	1,100	1,600	2,100
Fly Ash	tonnes/yr	1,700	2,300	3,500	4,700	7,000	9,400

1. For this analysis, biomass sulfur content was 0.02% and ash content was 0.9%. Coal sulfur content was 1.9% and ash content was 8.8%

\* Liquid effluents are negligible, and therefore not included here.

## BIOMASS CO-FIRING

Table 4. Resource requirements.

Indicator Name	Units	Base Year					
		1997	2000	2005	2010	2020	2030
Total Plant Capacity (net)	MW	100	100	150	200	300	400
Total Biomass Capacity (net)	MW	10.0	15.0	22.5	30.0	45.0	60.0
Land Required for Biomass Storage & Equipment*	m <sup>2</sup> /MW	84	84	84	84	84	84
	ha	0.084	0.126	0.189	0.252	0.378	0.504
Land Required for Energy Crops <sup>†</sup>	ha/MW	470	404	351	311	253	253
	ha	4,732	6,057	7,907	9,333	11,386	15,182
Water	m <sup>3</sup>	0.0	0.0	0.0	0.0	0.0	0.0

\* The m<sup>2</sup>/MW values are based on a biomass power capacity of 15 MW.

† The energy crop yields were assumed to increase linearly from 9.4 to 17 dry tonnes/ha/yr (4.1 to 7.5 dry tonnes/acre/yr) from years 1997 to 2020. Yields are assumed to remain constant between 2020 and 2030.

According to Parsons Power [2], based on equipment specifications and experience with similar systems, the storage and handling equipment for a 15 MW biomass system will require an area with dimensions of approximately 15 x 18 m (50 x 60 ft), or about 0.027 ha (0.067 acres). The total additional land requirements, including equipment and fuel storage areas, for a co-firing retrofit designed for supporting 15 MW of biomass power capacity would be about 0.126 ha (0.31 acres).

Water: Increases in water consumption at the plant are considered to be negligible compared to coal-only operation.

### 6.0 References

1. Winslow, J.C., S.M. Smouse, and J.M. Ekmann, et al., Cofiring of coal and waste, IEA Coal Research, London: August 1996. Report IEACR/90.
2. Utility Coal-Biomass Co-firing Plant Opportunities and Conceptual Assessments, Antares Group Inc., Landover, MD, and Parsons Power, Reading, PA, for the Northeast Regional Biomass Program, and the U.S. Department of Energy: November 1996.
3. Hughes, E., and D. Tillman, Biomass Cofiring: Status and Prospects, Electric Power Research Institute, and Foster Wheeler Environmental Corp.: November 1996.
4. Wood Fuel Cofiring at TVA Power Plants--Volume 1: Retrofitting Existing Boilers to Cofire Wood Fuel, Ebasco Environmental for Electric Power Research Institute: June 1993. Report 3407-1.
5. Energy Information Administration, Annual Energy Outlook 1996 with Projections to 2015, DOE/EIA-0383(96), January 1996.
6. U.S. House of Representatives, Clean Air Act Amendments of 1990, Report 101-952, October 1990.

## BIOMASS CO-FIRING

7. Energy Information Administration, Emissions of Greenhouse Gases in the United States 1995, DOE/EIA - 0573(95), October 1996.
8. Moore, T., "Harvesting the Benefits of Biomass," EPRI Journal, May/June 1996, p. 16.
9. Turnbull, J., "Strategies for Achieving a Sustainable, Clean and Cost-Effective Biomass Resource," Proceedings: Strategic Benefits of Biomass and Waste Fuels, Electric Power Research Institute, December 1993, EPRI TR - 103146.
10. BIOPOWER: Biomass and Waste-Fired Power Plant Performance and Cost Model, Electric Power Research Institute: March 1995. Report EPRI/TR-102774.
11. Easterly, J.L., Overview of Biomass and Waste Fuel Resources for Power Production, Proceedings: Strategic Benefits of Biomass and Waste Fuels, Electric Power Research Institute, December, 1993, EPRI/TR-103146.
12. Steam: It's Generation and Use, Babcock & Wilcox, Baberton, Ohio, 1992.
13. Technical Assessment Guide, Electricity Supply - 1993, Electric Power Research Institute: June 1993. Report EPRI/TR-102276-V1R7.
14. Komanoff, C., Power Plant Cost Escalation - Nuclear and Coal Capital Costs, Regulations, and Economics, Komanoff Energy Associates, New York, NY: 1981.
15. Easterly, J., Biomass Processing and Handling Assessment for Biomass-Fueled Power Plants, prepared for National Renewable Energy Lab: March 10, 1994.
16. Energy Information Administration, Electric Power Annual 1995--Volume I, DOE/EA.-0348(95), July 1996.

### Additional References

17. Benjamin, W., Building Biomass into the Utility Fuel Mix at NYSEG: System Conversion and Testing Results for Greenidge Station, Proceedings of The Seventh National Bioenergy Conference, Nashville, TN (September 1996).
18. Guidelines for Co-Firing Refuse-Derived Fuel in Electric Utility Boilers, Electric Power Research Institute: June 1988. Report 1861-1.
19. Strategic Analysis of Biomass and Waste Fuels for Electric Power Generation, Electric Power Research Institute: December 1993. Report EPRI/TR-102773.
20. Environmental Protection Agency, The National Allowance DataBase Version 2.0 Technical Support Document, EPA/400/1-91/028, Office of Atmospheric and Indoor Air Pollution, June 1991.
21. Langr, K., A Comparison of Wood, Coal, and RDF Combustion Systems - Focus on N.S.P. Bay Front and French Island, Proceedings of the Biomass Combustion Conference, Reno, Nevada (January 1992).
22. Economic Benefits of Biomass Power Production in the U.S., Meridian Corporation, Alexandria, VA, and Antares Group Inc., Landover, MD, for the National Renewable Energy Laboratory, Golden, Colorado.

## **BIOMASS CO-FIRING**

23. Piscitello, E.S., and C.P. Demeter, Biomass Co-firing Analysis Summary, Antares Group Inc.: May 1992.
24. Technical Assessment of Waste-to-Electric Energy Options--Final Report, Volume 1, Rural Electric Research : February 1992. Report 90-4.
25. Tewksbury, C., Design and Operation of a 50-MW Wood-Fueled Power Plant, Proceedings of the Energy from Biomass and Wastes, Institute of Gas Technology (1987).
26. U.S. Department of Energy, Electricity from Biomass: A Development Strategy, Office of Solar Energy Conversion, April, 1992.
27. Tillman, D.A., Cofiring Wood Waste in Utility Boilers: Results of Parametric Testing and Engineering Evaluations, 1996 Joint Power Generation Conference, Vol. 1, ASME, Foster Wheeler Environmental, 1996.

## OVERVIEW OF GEOTHERMAL TECHNOLOGIES

### Introduction

Geothermal energy, the natural heat within the earth, arises from the ancient heat remaining in the Earth's core, from friction where continental plates slide beneath each other, and from the decay of radioactive elements that occur naturally in small amounts in all rocks.

For thousands of years, people have benefited from hot springs and steam vents, using them for bathing, cooking, and heating. During this century, technological advances have made it possible and economic to locate and drill into hydrothermal reservoirs, pipe the steam or hot water to the surface, and use the heat directly (for space heating, aquaculture, and industrial processes) or to convert the heat into electricity.

The amount of geothermal energy is enormous. Scientists estimate that just 1 percent of the heat contained in just the uppermost 10 kilometers of the earth's crust is equivalent to 500 times the energy contained in all of the earth's oil and gas resources [1].

### Hydrothermal and Hot Dry Rock

This document characterizes electric power generation technology for two distinct categories of geothermal resources.

Hydrothermal resources are the "here-and-now" resources for commercial geothermal electricity production. They are relatively shallow (from a few hundred to about 3,000 meters). They contain hot water, steam, or a combination of the two. They are inherently permeable, which means that fluids can flow from one part of the reservoir to other parts of the reservoir, and into and from wells that penetrate the reservoir. In hydrothermal reservoirs, water descends to considerable depth in the crust, becomes heated and then rises buoyantly until it either becomes trapped beneath impermeable strata, forming a bounded reservoir, or reaches the surface as hot springs or steam vents. The water convects substantial amounts of heat from depths to relatively near the surface.

Hot Dry Rock (HDR) resources, on the other hand, are relatively deep masses of rock that contain little or no steam or water, and are not very permeable. They exist where geothermal gradients (the vertical profile of changing temperature) are well above average ( $>50^{\circ}\text{C}/\text{km}$ ). The rock temperature reaches commercial usefulness at depths of about 4,000 meters or more. To exploit hot dry rock, a permeable reservoir must be created by hydraulic fracturing, and water from the surface must be pumped through the fractures to extract heat from the rock.

There are both strong similarities and large differences between hydrothermal and HDR geothermal resources and exploitation systems. Most of the component technologies, i.e., the power plant and well drilling methods, are very similar for both systems. The most important differences are that: (a) Hydrothermal systems are commercial today, while HDR systems are not, whereas (b) HDR resources are enormously larger (between 3,170,000 EJ and 17,940,000 EJ of accessible energy in the U.S.) than hydrothermal resources (on the order of 1,060 EJ to 5,300 EJ of accessible energy) [2]. By way of comparison, in 1995 the U.S. used about 95 EJ of primary energy. U.S. hydrothermal sources could supply that amount for 10 to 50 years. But U.S. Hot Dry Rock resources could supply that amount for somewhere between 30,000 and 500,000 years.

Because of these differences, the general strategic approach of national geothermal R&D programs (including that of the U.S.) has been to try to lower costs in the hydrothermal commercial arena today and, by so doing, to improve generic "geothermal" technology enough to make HDR exploitation economically feasible in the not-too-distant future.

## OVERVIEW OF GEOTHERMAL TECHNOLOGIES

### Hydrothermal Features

Hydrothermal resources are categorized as dry steam (vapor dominated) or hot water resources, depending on the predominant phase of the fluid in the reservoir. Although the technology is similar for both, dry steam technology is not included in this Technology Characterization because dry steam resources are relatively rare. Hot water resources are further categorized as being high temperature ( $>200^{\circ}\text{C}/392^{\circ}\text{F}$ ), moderate temperature (between  $100^{\circ}\text{C}/212^{\circ}\text{F}$  and  $200^{\circ}\text{C}/392^{\circ}\text{F}$ ), and low temperature ( $<100^{\circ}\text{C}/212^{\circ}\text{F}$ ). Only the high and moderate temperature resources are adequate for commercial power generation.

Two separate power generation technologies, flash and binary, are characterized. The boiling temperature of water depends on its pressure, so as the pressure of the high temperature geothermal fluid is lowered in the plant, a portion (about 10 to 20% of it, depending on temperature and pressure) "flashes" to steam, which is used to drive a turbine to produce electricity. For moderate temperature resources, binary technology is more efficient. It is termed "binary" because the heat is transferred from the geothermal fluid to a secondary working fluid with a lower boiling temperature than water. The secondary fluid, vaporized by the heat, drives the turbine.

Beginning commercially in the 1950s, hydrothermal electric power generation has grown into an active and healthy, albeit not large, industry. About 7,000 MW of electric generation capacity have been developed worldwide, including about 2,800 MW in the U.S. [3]. Supply and demand forces and anticipated restructuring in the U.S. electric markets have resulted in very low demand for new geothermal capacity since 1990. However, geothermal energy is competing very well in markets outside the U.S., especially in Indonesia and the Philippines, where demand is high, geothermal resources are plentiful, and government policy is favorable. Approximately 2,000 additional MW will likely be developed worldwide in 1996 through 2000, with the majority of this being in Asia.

### Hot Dry Rock Features

Flash or binary technology could be used with HDR resources depending on the temperature. However, because of the constraints imposed by high well costs, a larger portion of the accessible HDR resource will produce well-head fluids in the moderate temperature range. Therefore, binary technology is characterized for HDR resources.

To date, HDR resources have not been developed commercially for two reasons. Well costs increase exponentially with depth, and since HDR resources are much deeper than hydrothermal resources, they are much more expensive to develop. Also, although the technical feasibility of creating HDR reservoirs has been demonstrated at experimental sites in the U.S., Europe, and Japan, operational uncertainties regarding impedance (resistance of the reservoir to flow), thermal drawdown over time, and water loss make commercial development too risky.

### Resource Details

In the U.S., the higher quality geothermal resources (both hydrothermal and HDR) are predominately located in the western states, including Alaska and Hawaii, as shown in the map below. Development of hydrothermal resources for electric power generation has been limited to California, Nevada, Utah, and Hawaii. Most of the western U.S. contains HDR resources, with the highest grade resources probably located in California and Nevada.

Scientists have made various estimates of the geothermal resource in the U.S. The U.S. Geologic Survey (USGS) completed the nation's most comprehensive assessment of geothermal resources, documented in USGS Circular 790, published in 1978 [2]. Circular 790 estimated the known, accessible hydrothermal resource to be about 23,000 MW

## OVERVIEW OF GEOTHERMAL TECHNOLOGIES

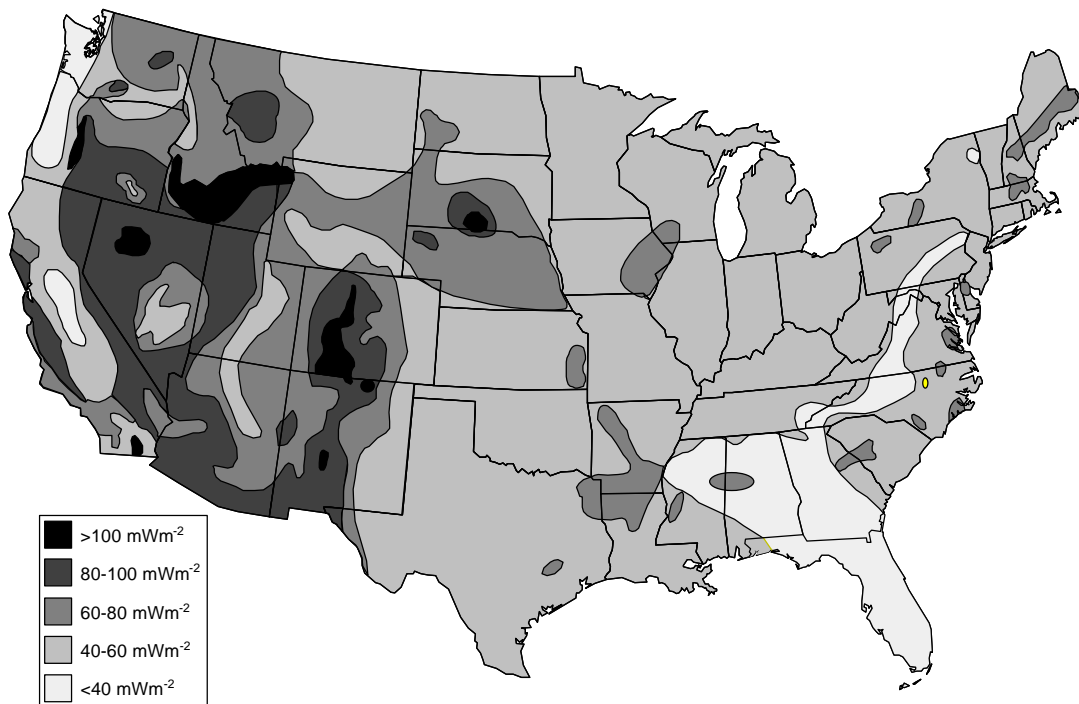

[peri-gtmap-8.pre, 9/97]

Figure 1. Geothermal resource quality in the United States.

of electric capacity for 30 years, and the as yet undiscovered accessible hydrothermal resource to be 95,000 to 150,000 MW of electric capacity for 30 years. It should be noted that the accessible resource is that which is accessible with current technology, but not necessarily economic. Considerable geothermal exploration and development in the U.S. since the mid 1950s has identified and characterized (moderately well) about 3,000 to 5,000 MW of hot water hydrothermal resources. Exploration work in the Cascade Mountains of Oregon in the 1990s seems to preclude the existence of the significant hydrothermal resource once estimated for that area.

An unpublished study by the University of Utah Research Institute in 1991 estimated about 5,000 MW of electric capacity for 30 years would be available at a cost of 5.5¢/kWh [4]. Recent preliminary analyses by the authors of the geothermal TCs suggest that for Hydrothermal electricity in 1997, no capacity would be available at  $\leq 2\text{¢/kWh}$ , about 5,000 MW would be available at  $\leq 3\text{¢/kWh}$ , and about 10,000 MW available at  $\leq 5\text{¢/kWh}$ . If the predicted technology improvements for 2020 hold true, then 6,000 MW would be available at  $\leq 2\text{¢/kWh}$ , about 10,000 MW available at  $\leq 3\text{¢/kWh}$ , and about 19,000 MW available at  $\leq 5\text{¢/kWh}$ . (These prices are levelized in constant dollars, using the “GenCo” financing assumptions described in Chapter 7.) Also note that the lowest prices given here are lower than the price calculated for the characterized geothermal flash power plant because the characterized plant is for a “typical” rather than “least expensive” geothermal high-temperature reservoir.

Although the potential of the nation's HDR resource has been studied less and is less well understood, it is believed to be very much larger than that of the hydrothermal resource. Tester and Herzog estimated the U.S. high grade HDR resource to have the potential of generating 2,800,000 MW at a cost  $\leq 8.7\text{¢/kWh}$  (1996\$) using 1990 technology [5]. For the year 2020 technology projected in the Hot Dry Rock TC, the current authors estimate that about 2,000,000 MW would be available from very high quality resource regions at  $\leq 5\text{¢/kWh}$ , and that as much as 17,000,000 MW (about

## OVERVIEW OF GEOTHERMAL TECHNOLOGIES

24 times the current installed electric capacity in the U.S.) of HDR would be available at  $\leq 6\text{¢/kWh}$ . (The economic assumptions here are the same as stated in the paragraph above.)

### Aspects of Cost Estimates

The current state of many aspects of geothermal technology is fairly well documented. Indeed, the timing of this characterization of geothermal technologies is opportune in that it follows the first major engineering analysis of the cost and performance of geothermal power plants in 15 years. The "Next Generation Geothermal Power Plants" study (NGGPP), published in 1996, characterizes current flash and binary technology and evaluates new technologies proposed for the next generation of geothermal power plants [6]. Prior to this study, it has been difficult to obtain current cost and performance data for geothermal power plants because of the proprietary nature of this information.

The Hydrothermal and Hot Dry Rock TCs incorporate much data from the NGGPP. However, the characterization of Hydrothermal Flash reflects decreased flash plant capital costs (approximately 40% less than those documented in the NGGPP) due to intense competition. As of mid-1997, capital costs for binary plants appear to have been unaffected by these factors.

The HDR technology characterization depends on the NGGPP for binary power plant cost and performance data. The NGGPP includes an analysis of HDR technology that some believe is too conservative. The current HDR characterization is based on a higher grade HDR resource than that in the NGGPP. The NGGPP HDR well cost (including fracturing) estimates were about 30% higher than the TC HDR well costs, which were estimated by an experienced geothermal drilling engineer based on the costs of deep geothermal wells drilled recently in Nevada. The costs of creating the HDR reservoir, as well as its performance, are based on estimates of HDR scientists at Los Alamos National Laboratory, where HDR has been studied for the last 20 years.

### Projections of Technology Improvements

For geothermal, as for other renewable energy electric supply technologies, the "accuracy" of projections of improvements in cost effectiveness are very important because in many instances, use of the technologies at specific locations will not be cost effective until the technologies are improved somewhat. The projections for improvements in the cost and performance of hydrothermal and HDR technologies are a synthesis of what various experts believe is possible.

The projections for improvements in hydrothermal technology are based on trends in performance and cost since about 1985 when U.S. firms first started constructing many hydrothermal power systems. It has been apparent that for both wells and power plants, the earliest forms of the technologies -- borrowed more or less wholly from other industries and uses -- have been constantly analyzed, rethought, and improved. The past five years especially have seen much new attention focused on how to improve the cost effectiveness of power plants, through changes in the underlying process cycles and conditions used to convert heat to electricity.

The single major exception to this ten-year (1985-1995) trend of apparent improvements has been in the area of industry's ability to locate and target, in many reservoirs, high-permeability zones for fluid collection and delivery. But here too, constant theoretical progress is being made, that is soon likely to engender practical progress.

The estimates for current and projected HDR cost and performance are more speculative than those for hydrothermal technology since HDR technology is much less mature and has not been applied commercially. Therefore, there is greater uncertainty in the HDR technology estimates. With HDR technology, the stated estimates are for the best cost



## OVERVIEW OF GEOTHERMAL TECHNOLOGIES

and performance that is reasonably possible; the estimated uncertainty values reflect the possibility of lower performance and less improvement in the technology.

The projections are predicated on various assumptions about factors that will affect the timing and extent of improvements in the technologies. These include the levels of funding for hydrothermal and HDR R&D in several countries, as well as fossil fuel drilling and well completion R&D, supply and demand in electricity markets, supply and demand in petroleum markets (this greatly influences drilling costs and private funding of drilling research), public policy (especially regarding energy and the environment) in several countries, currency fluctuations, and technological progress in other electric supply technologies.

### References

1. Duffield, W.A., J.H. Sass, and M.L. Sorey, "Tapping the Earth's Natural Heat," U.S. Geological Survey Circular 1125, 1994.
2. Muffler, L.J.P., ed., "Assessment of Geothermal Resource of the United States -- 1978," U.S. Geological Survey Circular 790, 1979.
3. U.S. Department of Energy, Energy Information Administration, Annual Energy Outlook 1996, DOE/EIA-0603(96), August 1996.
4. U.S. Department of Energy, Energy Information Administration, Geothermal Energy in the Western United States and Hawaii: Resources and Projected Electricity Generation Supplies, U.S. Department of Energy, DOE/EIA-0544, September 1991.
5. Tester, J.W., and H.J. Herzog, Economic Predictions for Heat Mining: A Review and Analysis of Hot Dry rock (HDR) Geothermal Energy Technology, Massachusetts Institute of Technology: July 1990.
6. Brugman, J., Hattar, M., Nichols, K., and Y. Esaki, Next Generation Geothermal Power Plants, Electric Power Research Institute: February 1996. Report EPRI TR-106223.

# GEOTHERMAL HYDROTHERMAL

## 1.0 System Description

A geothermal hydrothermal system consists of a geothermal reservoir, wells, and a power plant. "Hydrothermal" means that the geothermal reservoir contains copious amounts of steam or hot water that can be brought to the surface.

A representative system using a water-cooled flashed-steam power plant is shown in Figure 1. The system includes technical processes to find reservoirs (exploration), to measure and manage reservoirs, and to match power plant designs to the characteristics of reservoirs. The geothermal reservoir contains hot aqueous fluids. The fluids are produced through wells similar to oil wells, and piped to the power plant. Geothermal steam or vaporized secondary working fluids drive a turbine-generator to make electricity. Waste heat is ejected to the atmosphere through condensers and cooling towers. Remnant geothermal liquids, including any excess condensate, are pumped back into the reservoir through injection wells. If present, non-condensable gases are removed from the system by gas ejection equipment and released to the atmosphere after any treatment mandated by emission regulations. Some emission control systems may produce sludges or solids that are disposed of in landfills. The nominal size characterized here is 50 MW<sub>e</sub>, the size commonly used by industry for system comparisons. Real-world system sizes range from 0.5 to 180 MW<sub>e</sub>.

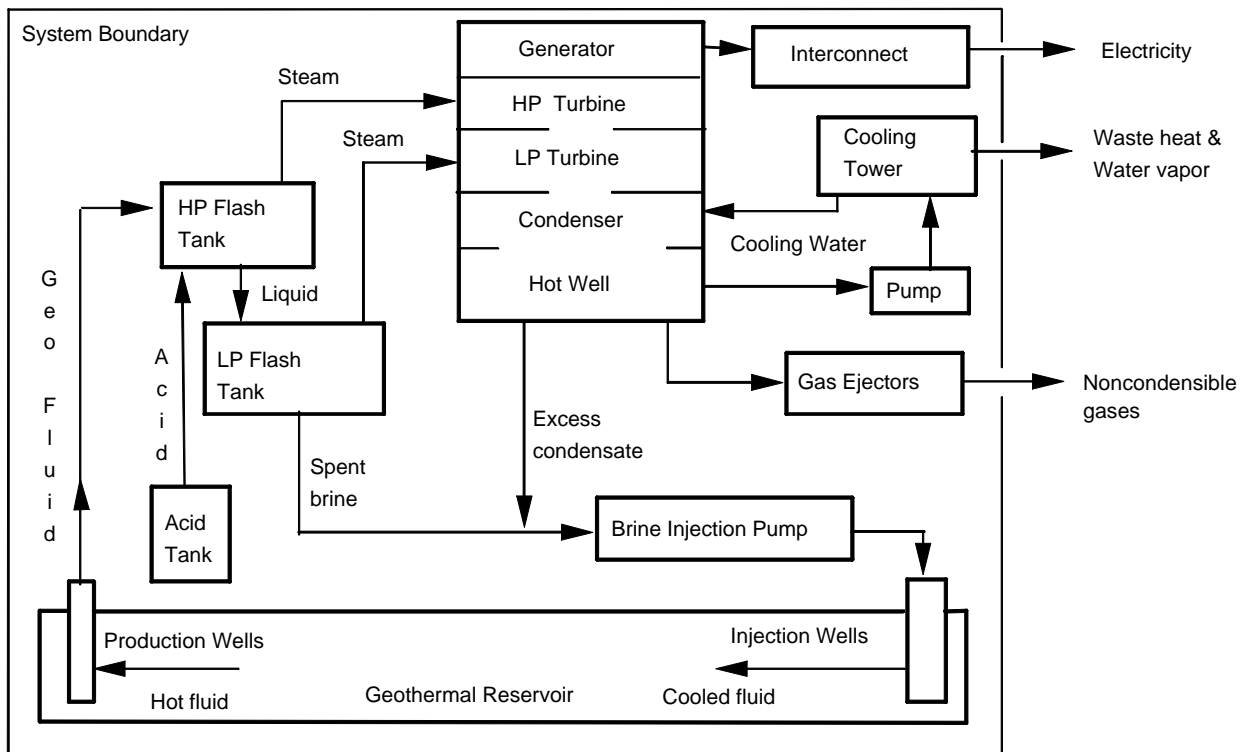

Figure 1. Geothermal hydrothermal electric system with flashed steam power plant schematic.

The technology design, performance, and cost of these systems are markedly affected by the reservoir temperature. In general, the higher the temperature, the lower the cost, because higher temperature fluids contain more available work. To reflect that variation, this Technology Characterization (TC) includes systems useful for high-temperature reservoirs (flashed-steam systems) and for moderate-temperature reservoirs ("binary" systems). Substantial detail about

## GEOTHERMAL HYDROTHERMAL

current performance and costs under a wide variety of reservoir conditions and power plant technologies is available from the recent DOE/EPRI Next Generation Geothermal Power Plant (NGGPP) study, from which much of the information in this TC is drawn [1]. Additional general background information on geothermal electric technologies and resources can be found in [2] and [3].

### Major Common System Components and Features

- a. A geothermal hydrothermal reservoir consisting of hot rock with substantial permeability, and aqueous fluid in situ. The temperature of the fluid ranges from 100 °C to 400°C (212°F to 752°F). The fluid may contain substantial amounts of dissolved solids and non-condensable gases (particularly carbon dioxide and hydrogen sulfide).
- b. Wells for production and injection of geothermal fluids. These range in total depth from 200 to 3,500 meters at producing U.S. hydrothermal reservoirs. The wells are drilled and completed using technology for deep wells that has been incrementally adapted from oil and gas well technology since the 1960's. The produced fluids range from totally liquid to liquid-vapor mixtures (with two-phase flow at the wellhead). In some systems outside the U.S., the cooled liquid leaving the plant is disposed to the ground surface or streams, rather than injected.
- c. An exploration and reservoir confirmation process to identify and characterize the reservoir. This process is usually complex and can add substantial front-end cost to a hydrothermal project. Such costs are usually borne out of developer's equity and can be a large barrier to exploration projects. Those costs are accounted for in this TC but not represented in the system schematics.
- d. A reservoir design and management process whose goal is to optimize the production of electricity from the reservoir at least cost over the life of the system. Those costs are accounted for in this TC but not represented in the system schematics.
- e. Surface piping that transports fluid between the wells and the power plant equipment.
- f. A power plant that converts heat (and other energy) from the geothermal fluid into electricity. Power plants comprise: (a) One or more turbines connected to one or more electric generators. (b) A condenser to convert the vapor exiting from the turbine (water or other working fluid) to a liquid. (c) A heat rejection subsystem to move waste heat from the condenser to the atmosphere. Cooling towers (wet or dry) are used for most systems, but cooling ponds are also used. (d) Electrical controls and conditioning equipment, including the step-up transformer to match the transmission line voltage. (e) An injection pump that pressurizes the spent geothermal liquid from the power plant to return it to the geothermal reservoir through the injection wells. Representative power-conversion (power plant) technologies are described below.
- g. Activities and costs related to the operation and maintenance of the system over a typical 30-year useful life of an individual power plant and a 40- to 100-year production life for the reservoir as a whole.

### Flash (Flashed-Steam) Power Plants

The flash plant schematic in Figure 1 was simplified from diagrams of the CalEnergy Company, Inc. (CECI) Salton Sea Unit 2 power plant [4]. Technical descriptions of recently-built flashed-steam power systems can be found in descriptions of the Magma Power Company Salton Sea units [5]; CECI Salton Sea Unit 3 [6,7]; CECI Coso units [8,9]; and GEO East Mesa units [10]. The NGGPP report [1] provides a range of process and cost information.

## GEOTHERMAL HYDROTHERMAL

Equipment present in all or most flashed-steam systems includes:

- a. One or two large vessels, flash tanks, wherein part of the geothermal fluid vaporizes ("flashes") into steam at pressures less than the pressure in the reservoir. This steam, typically 18 to 25 percent of the mass of the fluid from the reservoir (for double flash plants), is sent to the high-pressure (HP) and low-pressure (LP) inlets of a turbine or turbines. The amount of steam depends on conditions in the reservoir and the designs of the production well and power plant. The remaining liquid ("brine") from the second flash tank (75 to 82 percent of mass) is disposed of in the injection wells. The turbine in the dual flash system shown has dual inlets to admit high pressure steam from the first flash tank, and low pressure steam from the second flash tank.
- b. Special features related to minimizing the deposition of silicate scale. For the plant depicted in the system diagram (but not at most U.S. flash plants), the geothermal brine contains substantial amounts of dissolved silica, which tends to precipitate upon equipment walls as hard scale if not treated. The ameliorating features may include:
  - (a) Elevation of the conversion cycle's brine exit temperature above that optimal for maximum power production. This tends to keep some of the silica in solution. This is the method of choice when silica problems are small to moderate.
  - (b) A "crystallizer-clarifier" system. This consists of a brine solids clarifier, and a return line from the clarifier that injects silica seeds into the first flash tank. In that case, the flash tanks are called "crystallizers" because the silica seeds prevent the precipitation of amorphous silica on the walls of the vessels and connecting pipes. The liquid from the second crystallizer is sent to a third large vessel, the "clarifier," in which the precipitation, flocculation, and removal of solid silica are completed.
  - (c) A "pH-modification" system (shown in the flash-system schematic in Figure 1). This provides the same functions as the crystallizer-clarifier system by injecting small quantities of acid upstream of the first flash tank to reduce the pH of the geothermal fluid.
- c. Gas ejection equipment. At reservoirs where the concentration of noncondensable gases (e.g., CO<sub>2</sub>) is high, substantial gas ejection equipment is attached to the condenser. The ejectors are driven by steam or electricity. If hydrogen sulfide in the gases require abatement, H<sub>2</sub>S control equipment is attached downstream of the ejectors.

### Binary Power Plants

Figure 2 shows a schematic of a geothermal binary power plant [1]. All the geothermal fluid passes through the tube side of the primary heat exchanger and then is pumped back into the reservoir through injection wells. A hydrocarbon working fluid (e.g., isopentane) on the shell side of the primary heat exchanger is vaporized to a high pressure (HP) to drive the turbine-generator. Low pressure vapor from the turbine is liquified in the condenser and re-pressurized by the hydrocarbon pump. Waste heat is ejected to the atmosphere through a condenser and a cooling tower. Makeup water is required for the heat rejection system if wet cooling towers are used, but not if dry cooling towers are used. The binary system characterized here uses dry cooling, but wet cooling could be less expensive where cooling water is available. Most geothermal binary plants are constructed from a number of smaller modules, each having a capacity of 1 to 12 MW<sub>e</sub> net.

Technical descriptions of recently-built binary organic Rankine cycle power systems and other systems proposed for moderate-temperature reservoirs can be found in the NGGPP report [1] and others: binary systems [11]; vacuum-flash [12]; ammonia-based cycles [13].

Equipment present in most binary systems includes:

- a. Downhole production pumps in the production wells. These keep the geothermal fluid from vaporizing in the wells or in the power plant, and enhance the production well flow rate.

## GEOTHERMAL HYDROTHERMAL

- b. A working fluid pump, the "main cycle pump", that pressurizes the low-boiling-temperature liquid working fluid to drive it around the power-conversion loop.
- c. A turbine converts energy in the high-temperature high-pressure working fluid vapor to shaft energy. It exhausts low-temperature low-pressure vapor to a condenser.

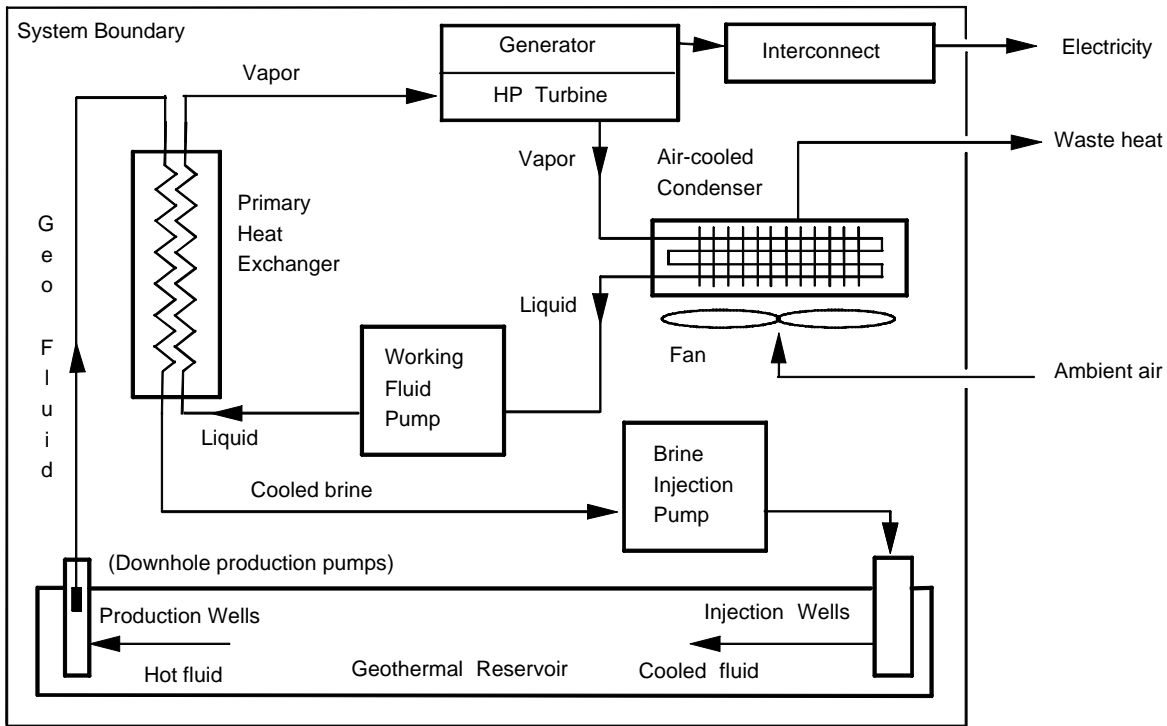

Figure 2. Geothermal hydrothermal electric system with binary power plant schematic.

### 2.0 System Application, Benefits, and Impacts

**Application:** Traditionally, geothermal systems have been perceived to compete with other baseload generation systems. Currently, geothermal electric systems compete most directly with gas-fired turbines and cogeneration systems in California, and coal and natural gas plants in Nevada. However, recent experiments have shown that some geothermal power plants (e.g., the dry steam plants at The Geysers) can be cycled to follow system load in the intermediate-baseload area of the utility time-demand curve [14], thereby increasing their value in certain applications. It is likely that load-following would be more difficult to do at flash and binary plants than at dry steam plants. Current contract capacity factors are on the order of 80 percent. Experienced capacity factors for many currently operating plants are on the order of 100 percent or higher (see discussion in Section 4.2)

**Benefits:** Typical plant sizes are 5 to 50 MW<sub>e</sub> net. Once the geothermal reservoir is confirmed, system construction time is on the order of a year or less. O&M costs are low compared to fossil-fueled systems because there are no "fuel" costs other than those for the O&M of the field wells and pipes. With appropriate emission control equipment, geothermal-generated electricity provides an environmentally attractive alternative to baseload gas, oil, coal, and

## GEOTHERMAL HYDROTHERMAL

nuclear-fueled electricity. Some in the U.S. geothermal industry have recently indicated interest in using relatively small geothermal power plants (from 50 kW to 2,000 kW) to supply off-grid or "mini-grid" power in a number of remote places that are favored with geothermal resources.

**Economic Conditions:** The recent surge in competition from low-cost electricity from natural gas has broad implications for the economic competitiveness of geothermal electric systems. Approximately 900 MW<sub>e</sub> of geothermal hydrothermal systems were installed in the western U.S. between 1980 and 1990. However, since about 1990, the advent of cheaper electricity from natural-gas fueled systems and low load growth rates have slowed the pace of U.S. domestic geothermal installation to nearly zero. (One 40 MW<sub>e</sub> plant was installed at the Salton Sea, California reservoir in 1996, under a high-price-of-power contract that originated in the early 1980's.)

In 1990, geothermal power developers expected to be able to compete easily against 6 to 7¢/kWh power in 1996. But by about 1993, the developers found themselves competing (not very successfully) against 2.5 to 3.5¢/kWh power in western states. However, it was expected that the currently strong overseas markets for these systems, especially in the Philippines and Indonesia, would continue to provide a strong experiential base for ongoing technology improvements. With the large recent decreases in the cost of geothermal flash power plants, U.S. technology for using higher-temperature geothermal resources may be able to again compete for new electricity demand. (See "Special Note on Power Plant Costs," page 3-20, for more details.)

**Impacts:** All emissions stated in Table 1 are for flashed-steam plants [7]. Emissions for binary plants are essentially nil because the geothermal fluid is never exposed to the atmosphere. The zero value for sludge assumes use of "pH modification" technology at locations where silica scaling would otherwise be high. By comparison, sludge at 6 kg/MWh has been cited for the previously-used crystallizer/clarifier technology, circa 1985-90 [15].

Table 1. Environmental impacts of geothermal flashed steam plant.

Indicator Name	Units	Base Year						
		1997	2000	2005	2010	2020	2030	
Gaseous								
- Carbon Dioxide	kg/MWh	45	45	45	45	45	45	
- Hydrogen Sulfide	kg/MWh	0.015	0.015	0.015	0.015	0.015	0.015	
Liquid	kg/MWh	0	0	0	0	0	0	
Solid								
- Sludge	kg/MWh	0	0	0	0	0	0	

Note: Emissions for binary plants are essentially nil because the fluid is never exposed to the atmosphere.

### 3.0 Technology Assumptions and Issues

Geothermal (hydrothermal) electric technology is commercially available. The systems characterized here reflect ordinary conditions and technology for representative high-temperature (232°C/450°F) and moderate-temperature (166°C/330°F) hydrothermal reservoirs in the United States. Technologies for exploration, drilling, and reservoir analysis and management are essentially the same for the two types of systems. These systems represent conditions and technology that are similar to a High-Temperature system at Dixie Valley, NV (using dual-flash conversion technology today) and a Moderate Temperature system at Steamboat Hot Springs, NV (using Organic Rankine Cycle,

## GEOTHERMAL HYDROTHERMAL

i.e., "binary," technology today). The conditions and technologies selected for this TC broadly represent many aspects of commercial technologies for producing electricity from these resources [1].

Substantial room for improvement exists in most aspects of this technology, including both the fluid-production (exploration, wells, and reservoir management) and electricity-conversion (power plant) components. The cost of deep geothermal wells is expected to decline by about 20 percent in 5 to 10 years, mainly through improvements in drill bits. The cost of conversion technologies (power plants) should continue to decrease substantially over the next 5 to 15 years for lower-temperature systems (binary-like), but may not decrease much for higher-temperature (flash) systems because of recent very large reductions in the cost of those systems. The current main thrusts for reducing power plant costs are: (a) substantial changes in the basic conversion cycle designs used in the plants, including the addition of "topping" cycles and "bottoming" cycles, improved working fluids, and the use of various hybrid cycles that merge the best features of flash and binary plants (e.g., see [1]); (b) urgent efforts on the part of owners of geothermal power systems to reduce O&M costs, especially by reducing the number of staff employed at each system and site, in anticipation of marked reduction in revenues when prices fall under certain contracts [16]; and (c) gradual reduction in complex instrumentation and controls as engineers learn what is safe to omit.

These improvements are expected to be relatively continual over the next 20 years, due to the combined effects of: (a) industry experience and learning from designing and installing these systems where they continue to be economic and (b) continuing R&D by the U.S., Japan, Italy, and other nations. In the U.S., the R&D effort is led by the Office of Geothermal Technologies, Office of Utility Technologies, Department of Energy, which has supported an active geothermal R&D program since 1974.

As detailed more in Section 4.0, it is believed that continued R&D would be valuable on many fronts, including: (a) development of geophysical methods to detect fluid-filled permeable fractures during exploration and siting of production wells; (b) substantial decreases in the cost of drilling geothermal wells; (c) moderate decreases in the cost of power plants, and moderate increases in the conversion effectiveness of plants sited on lower-temperature reservoirs; and (d) continuing decreases in the operation and maintenance costs of wells, field equipment, and power plants.

### General Methodology

Sources: Most of the performance and cost estimates for the 1997 technology has been drawn from the EPRI 1996 "Next Generation Geothermal Power Plants" (NGGPP) study [1]. Starting from the NGGPP estimates, this TC adds performance and cost factors to exploration and reservoir management processes to represent geothermal "field" technologies more accurately.

Scope: This TC includes both Flash Steam and "Binary" conversion systems because: (a) those technologies cover the temperature range at geothermal reservoirs currently under production; (b) they share many subcomponents, especially all aspects of finding, producing, and injecting geothermal fluids; (c) they serve the same markets; and (d) the distinctions of when to use them and what other conversion subsystem designs might modify or replace them are beginning to blur.

Process and Status: Industry and laboratory experts were interviewed to formulate the estimates of how these technologies will be improved over time. Processes to obtain such inputs have been active since 1989, when the Department of Energy Technology Characterization process was initiated. The estimates provided here are based on continuing updates of assessments conducted for OGT in 1990 and 1993 [17]. Polling of experts was renewed in 1997 because of large changes in some aspects of system designs and component costs.

## GEOTHERMAL HYDROTHERMAL

### 4.0 Performance and Cost

Tables 2 and 3 summarize the performance and cost indicators for the geothermal hydrothermal electricity systems being characterized in this report.

### 4.1 Evolution Overview

There is not a peer-reviewed literature on how much geothermal electric technology is likely to improve over time. However, there are published indicators that suggest hydrothermal-electric technology is immature and is frequently being improved along a number of fronts.

The estimated evolution of these systems assumes gradual improvements over time of many subsystems and components of the 1997 technology. Table 4 describes how some of the estimates of the cost of future technology were derived. Costs in that table are in 1997 dollars. The values in Table 4 reflect only some of the expected changes in technology, and then only for the high-temperature (flashed-steam) system, and not binary or other technologies.

Expected technology improvements and their sources, in brief, are:

- Average cost per well: Mid-term: Improved diamond compact bits, and control of mud circulation. Long-term: Costs drop markedly through radical improvements in drilling technology now being pursued for oil, gas, and geothermal wells. Cost savings for shallow wells will be smaller than for deep wells.
- Wildcat exploration success rate: The current value here implies that, on average, five deep wells need to be drilled to discover a new geothermal power-capable field. In the near-term (e.g., 10 years), most improvements will come from improved interpretations of local geology, in cross-comparison to geologies in other geothermal fields. In the long-term, sophisticated improvements in geophysical methods will make drilling targets (large water-filled fractures) relatively visible.
- Flow per production well: Combined impacts of better completions and improved reservoir engineering. Improved completions will reduce formation damage near the wellbore. Improved reservoir engineering will increase the degree to which the wellbore penetrates large-scale permeability.
- Field O&M cost: The 1990's effects of power sales contracts, i.e., lower payments for energy, established under PURPA (the Public Utilities Regulatory Policies Act of 1978) are now driving geothermal operators to identify cost-savings opportunities in plant O&M manpower. Also a result of improved chemistry and materials, but smaller effects than for power-plant O&M.



Table 2. Performance and cost indicators for a geothermal high-temperature system ("flashed-steam" technology).

INDICATOR NAME	UNITS	Base Case 1997		2000		2005		2010		2020		2030	
			+/- %		+/- %		+/- %		+/- %		+/- %		+/- %
Plant Size	MW	47.9		47.9		47.9		47.9		47.9		47.9	
Performance													
Levelized Capacity Factor	%	89	5	92	5	93	5	95	5	96	5	97	5
Annual Energy Production	GWh/year	390		403		407		416		420		425	
Power Plant Net Effectiveness	Wh/kg fluid	26.4	*	27.5		28.8		29.0		29.0		29.0	
Average Flow/Well	1000 kg/hr	304	*	322		342		368		402		435	
Average Cost/Well	\$1000	1,639	*	1,557		1,311		1,229		983		820	
Capital Cost													
Wildcat Exploration	\$/kW	46	10	44	+11/-10	32	+13/-10	25	+14/-10	17	+17/-10	12	+20/-10
Site Confirmation, Well Costs		100	†	93		76		69		53		43	
Site Confirmation, Soft Costs		18		17		16		16		15		13	
Siting & Licenses		64		64		64		64		64		64	
Land (@ \$5000/ha)‡		1		1		1		1		1		1	
Producing Wells & Spares		255	15#	224		174		154		115		90	
Dry Production Wells		64	5#	53		38		31		22		15	
Injection Wells		110	5#	96		74		64		47		37	
Field Piping		47	10	41		36		32		28		23	
Production Pumps		0		0		0		0		0		0	
Power Plant		629	10	629		629		629		629		629	
Owner's Costs		109	10	109		109		109		109		109	
Total Overnight Capital Cost		1,444	--	1,372		1,250		1,194		1,100		1,036	
Operations and Maintenance Cost													
Field, General O&M & Rework	\$/kW-yr	32.40	10	29.00	+11/-10	25.50	+13/-10	23.60	+14/-10	21.70	+17/-10	20.90	+20/-10
Makeup Wells		12.20		11.60		10.40		8.10		6.10		4.00	
Relocate Injection Wells		2.70		2.60		2.30		1.60		1.10		0.50	
Power Plant O&M		49.10		43.90		36.60		33.00		29.30		29.30	
Total Operating Costs		96.40		87.10		74.80		66.30		58.20		54.70	

Notes for Tables 2 and 3:

Plant construction period is assumed to require 0.8-1.5 years.

Column sums and totals may differ because of rounding.

\* Values depend highly on reservoir temperature, geology, and hydrology.

† The generic uncertainty factors (+10/-10, +11/-10, etc.) are explained in Section 4.2.

‡ Assumes desert land. Would be higher in agricultural areas.

# Uncertainty is for cost per unit well.

Table 3. Performance and cost indicators for a geothermal moderate-temperature system ("binary" technology).

INDICATOR NAME	UNITS	Base Case 1996		2000		2005		2010		2020		2030	
			+/- %		+/- %		+/- %		+/- %		+/- %		+/- %
Plant Size	MW	50.0	-	50.0		50.0		50.0		50.0		50.0	
Performance													
Levelized Capacity Factor	%	89	5	92	5	93	5	95	5	96	5	97	5
Annual Energy Production	GWh/Year	390		403		407		416		420		425	
Power Plant Net Effectiveness	Wh/kg fluid	11.6	*	11.8		12.2		12.8		13.3		13.9	
Average Flow/Well	1000 kg/hr	317	*	337		356		383		419		454	
Average Cost/Well	\$1000	492	*	467		443		418		393		344	
Capital Cost													
Wildcat Exploration	\$/kW	21	10	20	+11/-10	16	+13/-10	13	+14/-10	10	+17/-10	4	+20/-10
Site Confirmation, Well Costs		29	†	27		24		22		20		17	
Site Confirmation, Soft Costs		17		17		16		15		14		12	
Siting & Licenses		64		64		64		64		64		64	
Land (@ \$5000/ha)‡		1		1		1		1		1		1	
Producing Wells & Spares		148	15#	131		115		98		82		65	
Dry Production Wells		26	15#	21		18		14		11		8	
Injection Wells		69	15#	61		53		45		37		29	
Field Piping		35		31		27		23		19		15	
Production Pumps		46		43		40		36		32		29	
Power Plant		1,545		1,468		1,391		1,313		1,236		1,159	
Owner's Costs		109		109		109		109		109		109	
Total Overnight Capital Cost		2,112		1,994		1,875		1,754		1,637		1,512	
Operations and Maintenance Cost													
Field, General O&M & Rework	\$/kW-yr	28.80	10	25.60	+11/-10	22.30	+13/-10	20.50	+14/-10	18.80	+17/-10	18.40	+20/-10
Makeup Wells		7.10		6.70		6.00		4.70		3.60		2.30	
Relocate Injection Wells		1.70		1.60		1.40		0.80		0.30		0.10	
Power Plant O&M		49.80		44.60		37.20		33.40		29.70		29.70	
Total Operating Costs		87.40		78.50		66.80		59.50		52.40		50.50	

Notes: See notes at the bottom of Table 2.

## GEOTHERMAL HYDROTHERMAL

Table 4. Representative major technology improvements expected for flashed-steam system.

Technology Factor or Indicator	Units	1997 value	Performance or Cost Multiplier (relative to 1997 value)			
			2005	2010	2020	2030
a. Average cost per well	\$K	1,639	.80	.75	.60	.50
b. Wildcat dry hole ratio	ratio	0.80	.95	.90	.80	.70
c. Flow per production well	1000 kg/hr	304	1.12	1.20	1.30	1.40
d. Field O&M cost	\$/kW/yr	24	.75	.68	.62	.62
e. Power plant capital cost	\$/kW	629	1.00	1.00	1.00	1.00
f. Plant net effectiveness	Wh/kg	26.4	1.09	1.10	1.10	1.10
g. Plant O&M cost	\$/kW/yr	49	.75	.67	.60	0.50
h. Reservoir pressure decline:	%/yr	6	.85	.66	.40	.33

- Power plant capital cost: Expected to remain flat after mid-1990's large decreases in costs due to world-wide competition among suppliers.
- Plant net effectiveness: Improved due to better matching to reservoir conditions.
- Plant O&M cost: Similar to impacts in field O&M costs, above. Also expect continually higher degrees of automation in operation of power plants.
- Rate of reservoir pressure decline: The 6% decline per year set for Base Case (1997) technologies is higher than expected for fields developed at a reasonable pace. While this level of decline would require adding enough makeup wells to double the number of production wells by about year 20, its impacts on leveled costs and on the present value of reduced production in the final years are very small.

For hydrothermal electric systems as a whole, the estimated time to final commercial maturity is estimated to be 30 to 40 years. The time to maturity for major subcomponents is estimated as follows:

- Reservoir exploration and analysis technologies: 30 to 40 years. Substantial improvements in geophysical sensors and data inversion processing can be expected to occur over a long interval [18]. Also, advances in computer modeling of geochemical systems and rock-water interactions will provide substantial new information about underground conditions and long-term production processes [19].
- Conventional drilling technology: 10 to 20 years. The pace here will depend mainly on the pace of hydrothermal commercial development during the next 10 years, and the degree to which the 500-fold larger market for equipment for drilling oil and gas wells in harder rock at higher temperature improves technologies that the n will spill over to improve geothermal operations [20].
- Advanced drilling technology: 20 to 30 years. Systems studies are in progress for drilling technologies that could substantially reduce the costs of both removing rock and maintaining the integrity of the wellbore during

## GEOTHERMAL HYDROTHERMAL

drilling and production (i.e., alternatives to conventional casing). Such systems would be applicable to geothermal drilling under adverse conditions [21,22].

- Power plant technology: 10 to 20 years. Flash power plant technology is substantially mature, but analyses indicate that a number of cost-effective modifications of designs are possible [4,23]. Binary power plant technology is somewhat less mature [24,25].

### 4.2 Performance and Cost Discussion

The cost estimates in Tables 2 and 3 are in 1997 dollars. Capital costs are stated in dollars per kilowatt on an overnight construction basis. Costs not included specifically in Tables 2 and 3 are royalties to the owner of the geothermal resource at a (typical) rate of 10% of the fluid-production-related capitalized and O&M costs.

No single technology used in geothermal electric systems is immune to improvement through industry experience and basic and applied R&D. However, the most noticeable and measurable technology improvements that continue to produce large cost reductions will be in geothermal wells and in power plants.

The temporal pace of improvement in Tables 2 and 3 is similar to that used in the 1991 National Energy Strategy Current Policy Base Case. It generally assumes continued funding of the DOE Geothermal Research Program at the constant dollar budget levels of 1995-1997 to about 2010, plus an average 10 to 15 percent industry-experience-based learning curve effect through the year 2030.

**Capital Cost of Systems:** Anecdotal information has suggested that U.S. industry had wrung about 20 percent out of flash-system costs in the 1985 to 1990 period, and about 30 percent out of binary-system costs in the same interval. This rough quantification has been essentially verified by the statement by Elovic [26] that Ormat, Inc., managed to cut about 32 percent from the costs of its organic Rankine cycle (ORC) binary systems in the eight years between 1986 and 1994. Much of that improvement was attributed to changes in equipment design that lowered manufacturing costs.

Similar specific quantitative statements cannot be made for process- or manufacturability-related changes in geothermal flash electric power systems. It appears that the cost (in nominal dollars) estimated for Salton Sea power systems in the NGGPP study (estimates made in late 1993 [1]) is not much different from that stated for such plants when built in 1985 to 1987 [27]. This would represent improvements in cost effectiveness (after inflation) on a number of fronts, but especially the replacement of crystallizer-clarifier technology (at about \$17 million per 40 MW power plant in 1985) by pH-modification technology for silicate scaling control (at only a few million dollars per plant).

*Note: Power plant costs appear to have changed greatly in the past three years. Geothermal power plant capital costs could be substantially different from the estimates in this TC if there are moderate changes in the pace of power plant construction (in U.S. or abroad) or currency exchange rates. (See "Special Note on Power Plant Costs," page 3-20, for more details.)*

The cost of purchased land is estimated to be \$5,000 per ha for 10 ha, assuming desert land. Land costs in agricultural areas could be higher. This land accommodates the power plant, drilling pads (wellhead areas), and piping runs between wells and the plant. Power plant capital cost includes \$15/kW for the final line transformer.

**Cost of Wells:** It is difficult to track the "modal" or average cost of geothermal wells, because the cost depends markedly on well depth, the geology being drilled, the sequence of the well among all wells drilled in a field, the expertise of the drilling crew, and on the fact that relatively few geothermal wells are drilled each year. The prices of

## GEOTHERMAL HYDROTHERMAL

geothermal well component materials and services fluctuate with the demand for nearly identical components for oil and gas drilling. Those costs became extremely high (escalated rapidly) in the late 1970's and early 1980's, but de-escalated substantially in the mid-1980's as the world price of oil dropped dramatically.

Current R&D at Sandia National Laboratories promises to reduce the cost of drilling deep geothermal wells by 20 percent within the next 5 to 10 years [28]. Percentage cost reductions will be less for relatively shallow wells, such as those for the moderate-temperature case characterized here, since a higher fraction of the cost of those wells is in cement and casing whose costs are relatively inelastic with respect to improvement in drilling technology.

In the long run, say by about 2020, costs are expected to reach as little as 50% of current costs through radical improvements in drilling technologies, such as those being pursued by the National Advanced Drilling and Excavation Technologies (NADET) R&D program originated by the Department of Energy and now managed by the Massachusetts Institute of Technology [29].

**Other Reductions in Field Costs:** Other improvements of field technology will arise from a number of fronts. None of the fronts are easy to either quantify or predict. Some of the expected improvements are: (a) improved siting of production wells, through better means of interpreting geophysical data to detect permeable zones in reservoirs. This will result in increased success per attempted well, and increased average production flow per well; (b) less drilling damage to the wellbore, on average, from drilling operations per se, also increasing flow rates slightly; and (c) improved positioning and selection of injection wells, leading to fewer abandoned wells.

**Exploration Costs:** Two modes of "exploration" are included here: wildcat exploratory drilling and power plant siting after wildcat drilling. (a) Wildcat drilling includes regional assessments that culminate in the first deep well(s) being drilled in a geothermal "prospect" area. Wildcat wells usually encounter heat at depth, but encounter economic amounts of fluid and permeability only about 20 percent of the time in the U.S. (b) Exploration for plant siting occurs at reservoirs, prospects that have already been proven by wildcat drilling or subsequent additional drilling and production. This exploration, as well as production well siting in general, has the advantage over wildcat siting and drilling of information from nearby existing wells. So the likelihood of success is much higher, typically 80 to 95 percent.

Many of the enhanced geophysical methods that are expected to improve siting of production wells will also be applied to the siting of exploration wells. Many believe that a key path to improvements here is better understanding of the fractures and faults that define much of the permeability and boundaries of geothermal reservoirs [30,31]. Also, drilling costs for geothermal exploration will continue to decline, especially as more and more "slim holes" of about 10 cm diameter, costing about half that of 30 cm production-diameter wells, are used for wildcat drilling [32,33].

**Power Plant Capital Costs:** Power plant costs should continue to decrease for two primary reasons: (a) There will be improved conversion cycle designs that produce more electricity from each pound of geothermal fluid, and (b) There will be gradual reduction in the amount and number of instruments, controls, secondary valves, and safety systems as designers learn over time what can be excluded safely. But flash plant costs may stay flat over time because the large cost reductions experienced recently may have brought flash plant costs to near or below their long-term economic equilibrium point. (See "Special Note on Power Plant Costs," page 3-20, for more details.)

There are topping devices (e.g., Rotoflow turbine [4] and Rotary Separator turbine [34]) that extract extra power from very-high-temperature fluids, hybridized main cycles that extract extra power from moderate-temperature fluids (e.g., Kalina cycle [35] and Ormat "combined cycle" [36]), and bottoming cycles (e.g., vacuum-flash cycle [12]) being proposed and/or installed. Moreover, there is continued attention to how to simplify these plants to their bare essentials.

## GEOTHERMAL HYDROTHERMAL

**Operation & Maintenance Costs:** Annual O&M costs will decrease markedly for many sites, especially those within the U.S., and perhaps abroad. Until recently, the general employment rate for U.S. geothermal power plants was about one full time equivalent staff per MW of capacity. That is three to five times the rate for coal plants. With many of the U.S. power sales contracts for these power plants reaching and nearing the date for reversion of price of electricity to low avoided costs of power, the geothermal industry is working very hard to reduce the labor costs of operations [16]. Pacific Gas and Electric has cut its labor pool at The Geysers significantly [37], but that is due in part to retirement of some of PG&E's capacity there. No extensive statistics for changes in O&M expenditures for U.S. liquid-dominated geothermal power systems seem to be available publicly, but such information continues to be sought.

Since most of the operating costs of geothermal electric systems are fixed, no variable operating costs are shown in Table 1. In technical reports prior to the late 1980's a high variable operating cost for geothermal power plants is often shown; this is because those plants, often utility-owned and especially at The Geysers field, purchased steam or brine from a separate field-operating firm on an amount-consumed basis.

**Capacity Factors:** The availability and capacity factors of geothermal power systems tend to be much higher than the other baseload systems to which they are traditionally compared, coal and nuclear. This is because geothermal systems are intrinsically much simpler than the others. System availability factors (the percentage a year in which the system is capable of delivering its rated power) are historically very high, typically 95 percent or better [38].

Actual annual capacity factors equal to or greater than 100 percent have been reported. This is due to two trends in geothermal power plant design: (a) Generator ratings: Electric generators for geothermal service are usually ordered with an assumed power factor (a technical parameter of alternating current systems) of 0.85: for a gross generator rating of 50,000 kW, a generator sized at 58,800 kVa would be ordered. The generator ratings and costs in the NGGPP study [1] were set on this basis [39]. However, the real loads that these generators serve tend to have power factors of about 0.98-0.99. In those circumstances, the generator produces substantially more than 50 MWh of real energy per hour. Manufacturers' ratings sometimes show this effect [40,41]. (b) Redundant equipment: One (dry steam) plant at The Geysers was designed with redundant turbines and generators, to ensure a capacity factor of essentially 100 percent; the economics of doing so were favorable in the mid-1980's [42,43]. This approach could be used at flashed-steam and binary plants whenever economics warrant it.

"Capacity factor" is usually defined based on nameplate rating (i.e., capacity factor = kWh output/year ÷ ((nameplate kW) X 8,760 hours/year)). Therefore, the reported capacity factor of these plants can reach 108 to 112 percent if their annual availability is 98 percent. It is also worth noting that many contemporary geothermal power sales contracts set a "contract" capacity factor at 80 percent. If production falls below the contract capacity factor, the plant receives no capacity payments for a designated period, e.g., three months. That 80 percent value is sometimes cited as the typical geothermal actual capacity factor, but that is rarely the case.

The levelized capacity factors in Tables 2 and 3 reflect effects of decreased system output late in project life, e.g., in years 25-30, as it becomes uneconomic to replace production wells whose outputs might be declining. Such events are expected to be ameliorated by continuing improvements in reservoir management technologies.

**Expected Economic Life:** The 30-year life is the common U.S. design life for geothermal power plants. Pacific Gas & Electric's initial systems at The Geysers did operate for that life span. The effective life of geothermal production wells is usually shorter than that, and that has been taken into account in the costing here. The life of geothermal hydrothermal reservoirs can be much greater than 30 years, depending on how much capacity is installed. For example, The Geysers reservoir first produced power in 1960, and is expected to continue to operate until at least 2015. Reservoirs can be depleted in less than 30 years if too much capacity is installed. The life of reservoirs is generally improved by injection of fluid back into the producing formations.

## GEOTHERMAL HYDROTHERMAL

**Construction Period:** The construction period is typically reported as about 0.8 to 1.5 years. This period is that for erecting new capacity on a reservoir already discovered through exploration and fairly well characterized as to its production potential. Those prior activities, exploration and reservoir confirmation, can require 3 to 8 years of development work before installation of a first power plant on a reservoir [44]. (See Table 8, below, for allocation of capital costs over years before start up.)

### Basis and Interpretation of Estimates

This section provides information regarding some of the starting assumptions for the two technology cases, and provides information needed to use the cost and performance estimates in Tables 2 and 3 to derive estimates of the cost of electricity from geothermal systems.

**Sources of Estimates and Assumptions:** Most of the information used for characterization of the 1997 baseline technologies here comes from a 1995 study of current and "Next Generation Geothermal Power Plant" (NGGPP) designs. Conducted by CE Holt, a respected geothermal power system design and A&E firm, this is the first comprehensive set of cost estimates for U.S. geothermal power plants placed in the public domain in about 15 years [1].

Until that report, the level of detail of publicly-available information about the performance and cost of U.S. commercial geothermal electric systems was generally low. This is due in large part to the fact that almost all geothermal capacity built in the U.S. since 1985 was built under PURPA contracts. That shifted almost all geothermal power plant design and development from the Investor Owned Utility (IOU) domain to the Independent Power Producer (IPP) domain. IOU's have to report construction and operation costs, while IPP's do not. In addition, competition among IPP's intensified and contributed to a reduced flow of performance and cost information into the open literature, after about 1982. Until 1996, most of the detailed geothermal electric cost information published since 1982 came from systems installed in Italy, Mexico, the Philippines, and Japan.

This "geothermal information gap" was especially unfortunate because the 1981-1990 decade saw the development in the U.S. of two new major geothermal conversion schemes for liquid-dominated reservoirs: about 620 MW<sub>e</sub> of flash plants and about 140 MW<sub>e</sub> of binary plants [45]. The experience with these plants will define important aspects of geothermal electric technology for much of the next decade, but the technical details on the effectiveness of design tradeoffs and varied managerial approaches are largely not public and likely to remain so. The publication of the NGGPP study has now largely remedied this situation with respect to the performance and cost of geothermal power plants built, and to be built, in the U.S. However, details on the cost of geothermal wells and O&M costs in general are still mostly held closely in the private domain.

Three groups of changes were made to estimates from the NGGPP study, to make the results more reflective of "typical" geothermal hydrothermal reservoirs in the U.S.

- **Change 1:** The High Temperature system is that from Dixie Valley, Nevada. The initial reservoir temperature is 232°C (450°F). Dual flash technology is assumed for the 1997 system. Well depth is 3,050 m (10,000 ft). The field costs here were raised about 50 percent from those reported in the NGGPP study, by reducing the assumed flow per production and injection wells by one third. That was done to get the field capital costs to be about 30 percent of the total capital costs, which is the more-or-less modal case for flashed steam systems analyzed in the NGGPP study. Note that in some cases today, flash-binary hybrid power plants are being used at relatively high-temperature reservoirs. We assume that this may be the beginning of a trend, but stay with double-flash plants as our 1997 baseline technology for these reservoirs.

## GEOTHERMAL HYDROTHERMAL

- Change 2: The Moderate Temperature system is based at a 166°C (330°F) reservoir. Well depth is about 305 m (1,000 ft). The system assumes a partially-optimized Organic Rankine Cycle (ORC) conversion technology, using mixed working fluids, for the 1997 system. In the NGGPP study, this system was designed for an estimated reservoir at Vale, Oregon. Even though no working system exists at Vale, or is likely to in the near future, the Vale estimate was selected for use here because the initial resource temperature in that NGGPP case is a temperature for which there are working cost estimates from other sources. A reservoir with similar characteristics, but less expensive wells, is that at Steamboat Springs, Nevada, where a modest amount of ORC capacity is operating. Well costs were changed to approximately \$450,000 per well in 1993 dollars, estimated by an industry engineer familiar with drilling at Steamboat. So the Moderate Temperature system here is a composite of Steamboat Hills and Vale.
  
- Change 3: Certain costs were added or modified:
  - a. Wildcat exploration costs. Costs were added (see Table 7, equation FA) to account for "wildcat" exploration that accomplishes the initial discovery of hot fluid in a geothermal reservoir. The exploration included in the NGGPP cost estimates covered only the costs to confirm that a new power plant can be supported at a new site in a reservoir that has already been discovered.
  
  - b. Impacts of reservoir management. Effects of reservoir pressure decline were added, using simple models not documented here. The base cases assume 6 percent decline in pressure per year. Makeup production wells are added during the middle years of project life, and system output allowed to decline in the last years. The effects of this are (1) added costs for makeup wells and (2) calculation of the appropriate levelized capacity factor that includes effects of production decline. In addition, costs were added to account for a certain number of injection wells that are drilled ("relocated") after production begins to reduce cooling of productive zones.
  
  - c. Financing costs. The financing costs estimated in the NGGPP report were removed from the costs shown here. Finance costs are included in the estimate of COE in Chapter 7.

**Special Note on Power Plant Costs:** Geothermal flashed-steam power plants now cost about 40% less than four years ago (the NGGPP cost estimates were completed mid-1993). This applies not just to major equipment, but also to engineering services and plant construction. This is due to factors whose effects are difficult to quantify and differentiate, including: (1) intense competition in the electric equipment and power plant construction industry; (2) fluctuations in currency exchange rates; and (3) some simplifications and improvements in the designs of geothermal flash power plants.

Geothermal flash plants that cost \$1,100 to \$1,200 per kW in early 1994, now (in early 1997) cost about \$600 to \$800 per kW. It is believed that the same degree of cost change has not occurred for binary plants, due to a lack of competition in that segment of the geothermal market.

This general status of intense competition across the electric power industry, world-wide, was noted recently in Independent Energy magazine [46]. "Competition has driven down the price of new power plants -- as much as 40 percent in the last six years. A major reason for this is fierce competition among suppliers." The article states that only about 50 percent of world power-plant manufacturing capacity was being used in early 1997.

This Technology Characterization takes those effects into account by:



## GEOTHERMAL HYDROTHERMAL

After the adjustment, that cost was set at \$575 per kW, which was then escalated to \$629 in 1997 dollars. (There are at least four firms making flash turbo-generator units, and many plant construction firms.)

- The NGGPP estimate for the cost of the binary power plant was not changed, except for converting to 1997 dollars. (There is only one company that is very active in the manufacture and construction of binary power plants.)

Given these large recent variations in costs, the users of this Technology Characterization are urged to be cautious in applying the numerical values herein to real world situations without consulting engineering firms with substantial experience in estimating costs for geothermal power systems.

**Cost Deviation Estimates:** The error range ascribed to the base year (1997) estimates, for capital and O&M costs, is set at +/-10 percent to reflect best estimates of the general accuracy of the information on which the cost estimates are based. The upper bound set for the error range is assumed to grow linearly by an additional 10 percentage points between 2000 and 2030 to reflect the uncertainties associated with R&D forecasts.

Note that these cost estimates internally account for one of two other dominant sources of uncertainty:

Cost Contingency: The construction cost contingency is about 15 percent for field-related costs and 10 percent for power plant-related costs.

Reservoir Uncertainties: Uncertainties in measurements on reservoir properties can add on the order of 15 to 25 percent to the levelized cost of delivered electricity. The estimates provided in this TC are not quantified with respect to such uncertainties; it is believed that the present estimates represent something akin to an "industry's expected case."

These "measurement" uncertainties and the costs that are occasioned by them are subject to reduction through research and industry experience, and the scenario evaluated here estimates that such reductions will occur over time. Specifying and improving the quantification of these uncertainties is a continuing research priority.

**Factors for Estimating Cost of Electricity:** Costs of energy are not shown in this chapter. Such costs are shown and documented in Chapter 7 of this report. The reader should note that most U.S. geothermal electric systems installed in recent years have been owned by independent power producers (IPPs) rather than investor-owned utilities (IOUs). It is also the case that when IOUs have owned geothermal power plants in the U.S., they have almost always turned to a geothermal specialty company to develop and operate the field (wells and pipes). When this is the case, different tax write-offs apply to the field operation and the power plant operation.

Certain specialized factors are required for correct analysis of the economics of the field components of the system, e.g., fluid royalties, intangible drilling expenses, and depletion allowances. The values assumed for these factors are:

- Life for Federal Income Tax: Five years.
- Renewable Energy Tax Credit: This is 10 percent of capital cost of the system, up to but not including transmission equipment (Section 48 of Federal Tax Code). The basis for depreciation must be reduced by 50 percent of the credit taken.
- Expensing of Intangible Fraction of Well Costs: This study assumes the intangible fraction is 100 percent for exploration wells and 70 percent for production-related wells.

## GEOTHERMAL HYDROTHERMAL

- Percentage Depletion Allowance: 15 percent per year of field-related revenues (fraction of annual revenues attributable to field-specific investments, operating costs, and profits). In any year, percentage depletion may not exceed 50 percent of taxable income. If the field part of the project shows an annual loss, cost depletion may be taken.
- Geothermal Fluid Royalty Payments: The rates for royalties on Federal geothermal properties are a reasonable basis for estimating typical royalty costs. Federal royalties for liquid-dominated reservoirs are 10 percent annually of [project gross revenues minus power plant-related costs and returns to capital]. This is roughly equivalent to 10 percent of annual field-related costs and returns.
- Given the breadth of some of these incentives, Federal and state income tax calculations need to adhere to provisions for Alternative Minimum Tax.

**Working Model for Cost Estimation:** The estimates of project costs in Tables 2 and 3 are derived from more-fundamental estimates than shown in those tables. The primary technical estimates used are shown in Tables 5 (variables) and 6 (constants). Tables 7 and 8 document the formulas needed to derive capital and O&M costs, and system performance (levelized capacity factor and output.) Table 8 includes a column that documents the temporal pattern of expenditures. Note especially that wildcat exploration precedes other project costs by a considerable period. All costs in these tables are in 1997 dollars.

### 5.0 Land, Water, and Critical Materials Requirements

Land: The land use stated, 10 ha (10 hectare; 25 acres) for a 50 MW<sub>e</sub> plant, is that for direct occupancy for the power plant and surface disturbances due to wells and pipelines. Roads are not included in the estimate. The total well field area for the reference 50 MW<sub>e</sub> flash plant is on the order of 160 ha (400 acres). These are estimates made from general information, and apply to either flash and or binary systems.

Water: Water use for the reference dual flash plant is essentially nil because all of the cooling tower makeup comes from steam condensate, while still allowing the plant to meet typical requirements to reinject at least 80 percent of the geothermal fluids produced. Because the binary plant characterized here is air cooled, it consumes no cooling water.

## GEOTHERMAL HYDROTHERMAL

Table 5. Basic estimates of system characteristics.

ID	Item	Units	Base Year Value	
			Flash	Binary
<b>I. Capital Cost and Initial Performance:</b>				
eA	Power plant, capital cost	\$M	30.124	77.256
eB	Power plant net effectiveness	Wh/kg fluid	26.41	11.60
eC	Average cost per production well	\$M	1.639	0.492
eD	Wildcat exploration probability of success	ratio	0.20	0.20
eE	Wildcat non-drilling costs per unit	\$M	0.546	0.546
eF	Years wildcat cost carried to plant start up date	years	6	6
eG	Site confirmation, soft cost	\$M	0.874	0.874
eH	Production well probability of success *	ratio	0.80	0.85
eI	Number of injectors per producer †	ratio	0.5	0.5
eJ	Initial average flow per producer	1000 kg/hr	304.5	317.4
eK	Impact on flow of better completions ‡	ratio	1.00	1.00
eL	Impact on flow of better reservoir engineering ‡	ratio	1.00	1.00
eM	Cost, per downhole production pump #	\$M	0.0	0.154
eN	Gathering system cost, per active production well	\$M	0.212	0.080
<b>II. Operating Performance and Costs:</b>				
eQ	Power plant, general O&M cost	\$M/year	2.350	2.490
eR	Field general O&M cost	\$M/year	1.172	1.224
eS	Well general rework cost	\$M/year	0.382	0.218
eT	Field pressure decline	% per year	6	6
eU	Fraction of injectors relocated early in project	ratio	0.25	0.25
<b>III. System Output</b>				
eY	Nominal capacity factor	%	92	92
eZ	Capacity levelization factor **	%	97	97

Notes:

\* "Producer well probability of success" is the logical inverse of "producer well dry hole fraction." The latter term is more commonly used in the U.S. industry.

† Synonyms: producer -- production well; injector -- injection well.

‡ Initially 1.00, but expected to increase with improved technology.

# Downhole production pumps are used at binary systems only. Cost per pump (@ producers and spares).

\*\* Used to account for certain effects of reservoir pressure and well flow rate decline.

## GEOTHERMAL HYDROTHERMAL

Table 6. Fixed assumptions (constants, base year value).

ID Code	Item	Units	Flash	Binary
cA	System net size	MW	47.9	50.0
cB	Number of 50 MW plants over which to spread wildcat costs	integer	5	5
cC	Cost multiplier for first site test well	ratio	1.67	1.67
cD	Cost multiplier for second site test well	ratio	1.25	1.25
cE	Siting & Licenses	\$/kW	64	64
cF	Land	\$/kW	1	1

Table 7. Formulas for intermediate values.

Formula, Name	Units	Formula
FA, Wildcat exploration cost	\$M	$FA = (eC + eE) * (1/(eD)) * (1/cB)$ 'Regional cost; spread over five power plants.
FB, Confirmation well cost	\$M	$FB = (cC + cD) * eC$ 'Two wells, at decreasing cost per well.
FC, Flow per producer	kg/hr	$FC = eJ * eK * eL$ 'Improves due to better completions and reservoir engineering.
FD, No. active producers needed	number *	$FD = ((cA * 1000)/eB)/FC + 0.5 + 1.0$ 'Plant flow need divided by flow per producer, plus one spare.
FE, No. of initial dry producers	number	$FE = FD * (1/eH - 1)$ 'Accounts for dry holes in production drilling
FF, No. of initial injectors	number	$FF = FD * eJ$
FG, Producers, initial cost	\$M	$FG = FD * eC$
FH, Dry holes, initial cost	\$M	$FH = FE * eC$ 'Attempted producers that failed
FI, Injectors, initial cost	\$M	$FI = FF * eC$
FJ, Production pumps, initial cost	\$M	$FJ = eM * FD$ 'Unit cost times active producers plus spares
FK, O&M cost to capitalize and operate makeup wells	\$M/year	From detailed model and tables. 'One effect of {eT}
FL, O&M cost to relocate injector wells	\$M/year	From detailed model and tables. 'Effect of {eU}
FM, Levelized system output	kWh per year	$FL = 8760 * (eY * eZ / 1E4)$ 'Levelized system output

\* Value is not rounded (the 0.5 factor compensates) to avoid algebraic discontinuities (step functions) that are difficult to interpret in screening and policy studies. Planner of a real project would round well counts up to the nearest integer. The 1.0 factor provides for one spare producer.

## GEOTHERMAL HYDROTHERMAL

Table 8. Final values of costs, and temporal pattern of outlays.

Line, Formula or Source	Item	Base Year Value (1997\$ in 1997)		Annual Spend Pattern	Tax Aspects <sup>†</sup>
		Flash	Binary		
Capital costs (Units: \$/net kW, overnight costs)					
1, FA	Wildcat exploration cost	45.63	20.76	-6 100 <sup>‡</sup>	idc = 100
2, cE	Siting & licenses	64.00	64.00	-3 100	idc = 0 cd = 100
3, cF	Land (purchased)	1.00	1.00	-3 100	idc = 0 dep = 0
4, FB	Site confirmation, well costs	99.92	28.72	-3 100	idc = 100
5, eC	Site confirmation, soft costs	18.25	17.48	-3 100	idc = 50
6, FE	Producing wells, initial	255.15	148.30	Standard <sup>#</sup>	idc = 70
7, FD	Dry producers, initial	63.79	26.17	Standard	idc = 100
8, FG	Injection wells, initial	110.46	69.23	Standard	idc = 70
9, FF	Field piping, initial	47.29	35.29	Standard	idc = 0
10, FJ	Production pumps, initial cost	0.00	46.50	Standard	idc = 0
11, eA	Power plant	628.89	1,545.12	Standard	idc = 0
12,	Owner's costs	109.27	109.27	Standard	idc = 0
O&M Expenses (Units: \$/net kW, first year)					
13, eR	Field, general O&M	24.46	24.48	O&M	
14, eS	Wells, rework cost	7.98	4.37	O&M	
15, FK	Field, makeup producers	12.22	7.09	O&M	
16, FL	Field, relocated injectors	2.73	1.71	O&M	
17, eQ	Power plant, O&M cost	49.06	49.78	O&M	
Performance (Units: kWh per year)					
18, FM	System levelized output	7,817	7,817	NA	

Notes:

\* "6 100" means: 100 percent of the funds are spent in year 6 before startup. (The year immediately before the date of startup is counted as "year 1 before startup.")

<sup>†</sup> Tax aspects: -idc: Fraction expensed as intangible drilling cost (remaining fraction is depreciated). -cd: Depletable fraction on which cost depletion may be taken. -dep: Depreciable fraction (land is not depreciable)

<sup>‡</sup> The "6 year" delay shown here is a variable. See item eF in Table 5. This study estimates 6 years for 1997 - 2000, 5 years for 2005-2020, and 4 years for 2030 for all technologies.

<sup>#</sup> "Standard" spend pattern is 33% in year 2 and 67% in year 1 before startup.

## GEOTHERMAL HYDROTHERMAL

### 6.0 References

1. Brugman, J., M. Hattar, K. Nichols, and Y. Esaki, Next Generation Geothermal Power Plants, CE Holt Co., Pasadena, CA: February 1996. Report EPRI/RP 3657-01. Research supported in part by Office of Geothermal Technologies, U.S. Department of Energy.
2. Easwaran, E., and D. Entingh, United States Geothermal Technology - Equipment and Services for Worldwide Applications, Princeton Economic Research, Inc., for U.S. Department of Energy, Assistant Secretary for Energy Efficiency and Renewable Energy: 1995. Report DOE/EE-0044.
3. Walton, H.L., Geothermal Energy in the Western United States and Hawaii: Resources and Projected Electric Generation Supplies, DOE/EIA-0544, Energy Information Administration, Washington, D.C., September 1991 .
4. Hoyer, D., K. Kitz, and D. Gallup, "Salton Sea Unit 2 Innovations and Successes," Geothermal Resource Council Transactions, 1991, p. 355.
5. Clevinger, R.B., "Comparison of Magma Power Company's First Generation and Second Generation Dual Flash Geothermal Power Plants at the Salton Sea KGRA", Geothermal Resource Council Transactions, 1992, p. 543.
6. Forsha, M.D., and K. E. Nichols, "Geothermal Energy Rivals Fossil Fuel in Small Plants," Power Magazine , September 1991, p. 58.
7. Newell, D., et al., "Salton Sea California Geothermal Field, CA - Case History of Power Plant Cycle Selection , Design, Construction and Operation," Course on Geothermal Exploration and Power Plant Case Histories of the Western U.S., Geothermal Resources Council, September 1989.
8. Schoonmaker, J.L., "The Coso Geothermal Power Projects," Mission Power Engineering Co., Geothermal Resource Council Transactions, 1989, p. 645.
9. Schoonmaker, J.L., and M.F. Maricle, "Design and Construction of the Coso Geothermal Power Projects," Geothermal Resource Council Transactions, 1990, p. 1065.
10. Knox, L., and M.C. Moore, "GEO East Mesa Geothermal Project: Pumped Double Flash Technology," Geothermal Resource Council Transactions, 1990, p. 1029.
11. Elovic, A., "Advances in Binary Organic Rankine Cycle Technology," Geothermal Resource Council Transactions, 1994, p. 511.
12. Forsha, M., "Low Temperature Geothermal Flash Steam Plant," Geothermal Resource Council Transactions , 1994, p. 515.
13. Kalina, A.I., and H.M. Leibowitz, "Applying Kalina cycle technology to high enthalpy geothermal resources, " Geothermal Resource Council Transactions, 1994, p. 531.
14. Cooley, D., "A Report on Cycling Operations at The Geysers Power Plant," Geothermal Resources Council Transactions, September 1997, p. 729.

## GEOTHERMAL HYDROTHERMAL

15. Premuzic, E.T., M.S. Lin, and Sun Ki Kang, "Advances in Geothermal Waste Treatment Biotechnology," Geothermal Program Review X, Proceedings, Department of Energy, San Francisco, March 1991, p. 77.
16. Mason, T.R., "Improving the Competitive Position of Geothermal Energy," Proceedings of Geothermal Program Review XIV, Department of Energy Report DOE/EE-0106, April, 1996, p. 13.
17. Entingh, D.J., "Technology Evolution Rationale for Technology Characterizations of U.S. Geothermal Hydrothermal Electric Systems," BNF Technologies Inc., Alexandria, VA: March 1993. Draft Report.
18. "Research in Geothermal Reservoir Evaluation," Lawrence Berkeley National Laboratory, Research program report: 1991.
19. Duan, Z., N. Moller, J. Greenberg, and J. H. Weare, "Geothermal Brine Chemistry Modeling Program," Geothermal Program Review X, Department of Energy, Geothermal Division, San Francisco, CA, p. 117, March 1992.
20. Pierce, K.G., and B.J. Livesay, A Study of Geothermal Drilling and the Production of Electricity from Geothermal Energy, Sandia National Laboratories, Albuquerque, New Mexico: July 1992. Draft Report SAND92-1728.
21. Rauenzahn, R.M., and J.W. Tester, "Numerical simulation and field testing of flame-jet thermal spallation drilling - 2. Experimental verification," International Journal of Heat Mass Transfer, Vol. 34, No. 3., pp. 809-818 (1991).
22. Tester, J.W., and H.J. Herzog, "Economic Predictions for Heat Mining: A Review and Analysis of Hot Dry Rock (HDR) Geothermal Energy Technology," Energy Laboratory, Massachusetts Institute of Technology, Cambridge, MA: July 1990. Report MIT-EL 90-001.
23. DiPippo, R., and D.R. Vrane, "A Double-Flash Plant with Interstage Reheat: Thermodynamic Analysis and Optimization," Geothermal Resource Council Transactions, October 1991, p. 382.
24. Brugman, J., "Comments on the DOE Power Conversion Technology Program," Proceedings of Geothermal Program IX, CONF-913105, Department of Energy, San Francisco, CA, p. 213, March 1991.
25. Forsha, M.D. and K.E. Nichols, "Factors Affecting the Capital Cost of Binary Plants," Geothermal Resources Council Transactions, Vol. 15, Davis, California, October 1991, p. 99.
26. Elovic, A., "Advances in Binary Organic Rankine Cycle Technology," Geothermal Resources Council Transactions, 1994, p. 511.
27. Personal communication to D.J. Entingh, 1987.
28. Glowka, D.A., "Geothermal Drilling Research Program Overview," Proceedings of Geothermal Program Review XIV, DOE/EE-0106, Department of Energy page 217, April 1996.
29. Petersen, C.R., "National Advanced Drilling and Excavation Technologies Program and Institute," Proceedings of Geothermal Program Review XIV, DOE/EE-0106, Department of Energy, p. 239, April 1996.
30. Wright, P.M., D.L. Nielson, H.P. Ross, J.N. Moore, M.C. Adams, and S.H. Ward, "Regional Exploration for Convective-Hydrothermal Resources," Geothermal Science and Technology, Vol. 2, No. 2, pp. 69-124 (1989).

## GEOTHERMAL HYDROTHERMAL

31. Arnason, K. and O.G. Floventz, "Evaluation of Physical Methods in Geothermal Exploration of Rifted Volcanic Crust," Geothermal Resources Council Transactions, 1992, p. 207.
32. Finger, J.T., "Update on Slimhole Drilling," Proceedings of Geothermal Program Review XIV, DOE/EE-0106, Department of Energy, p. 225, April, 1996.
33. Olson, H.J., "Geothermal Reservoir Assessment Based on Slim Hole Drilling," Vol. 1 and 2, University of Hawaii, and GeothermEx, Inc., for the Electric Power Research Institute, Palo Alto, California: December 1993. Report EPRI/TR-103399,
34. Studhalter, W., D. Cerini, and L. Hays, "Demonstration of an Advanced Biphase Turbine at Coso Hot Springs," Geothermal Resources Council Transactions, October 1995, p. 475.
35. Leibowitz, H.M., and D.W. Markus, "Economic Performance of Geothermal Power Plants Using the Kalina Cycle Technology," Geothermal Resources Council Transactions, p. 1037, 1990.
36. Forte, N., "The 125 MW Upper Mahiao Geothermal Power Plant," Geothermal Resources Council Transactions, September 1996, p. 743.
37. Cooley, D., comments during presentation of "A Report on Cycling Operations at The Geysers Power Plant," Geothermal Resources Council Transactions, September 1997, p. 729.
38. "Availability of Geothermal Power Plants," Geothermal Progress Monitor No. 10, Geothermal Division, Department of Energy, p. 17, 1987.
39. Clarifications from CE Holt engineers.
40. Reference List: Geothermal Power Plants, Fuji Electric Co., Ltd., Tokyo: 1993.
41. List of Geothermal Power Plant (sic), Mitsubishi Heavy Industries, Ltd., Tokyo: 1991.
42. Bloomquist, R.G., J.D. Geyer, and B.A. Sifford III, Innovative Design of New Geothermal Generating Plants, Bonneville Power Administration Contractor: July 1989. Report DOE/BP-13609-5.
43. Sifford, A., R.G. Bloomquist, and J. Geyer, "PURPA Influence on Contemporary Geothermal Power Plants," Geothermal Resources Council Transactions, October 1987, p. 91.
44. Erskine, M.C., and E.P. Coyle, "Historical Perspective on the Time Necessary to Develop Geothermal Power in the United States," Geothermal Resources Council Bulletin, August 1988, p. 6.
45. Rannels, J.E., and L. McLarty, "Geothermal Power Generation in the United States, 1985 Through 1989," Geothermal Resources Council Transactions, August 1990, p. 292.
46. Burr, M. T., "Sharper Pencils," Independent Energy, June 1997, pp. 10 - 13.



# GEOHERMAL HOT DRY ROCK

## 1.0 System Description

The Hot Dry Rock (HDR) concept uses heat recovered from subsurface rocks to generate electricity. The system proposed for extracting heat from the rock and converting it to electricity is comprised of two distinct subsystems (see Figure 1) at very different stages of their technological evolution. The two subsystems are the power plant (on the surface) and the HDR reservoir (deep beneath the surface), which are connected by deep wells. The wells and reservoir are thought of as a single system, often referred to as the well field system or reservoir system. The power plant system is largely identical to commercial binary hydrothermal electric plants. The technology for the reservoir

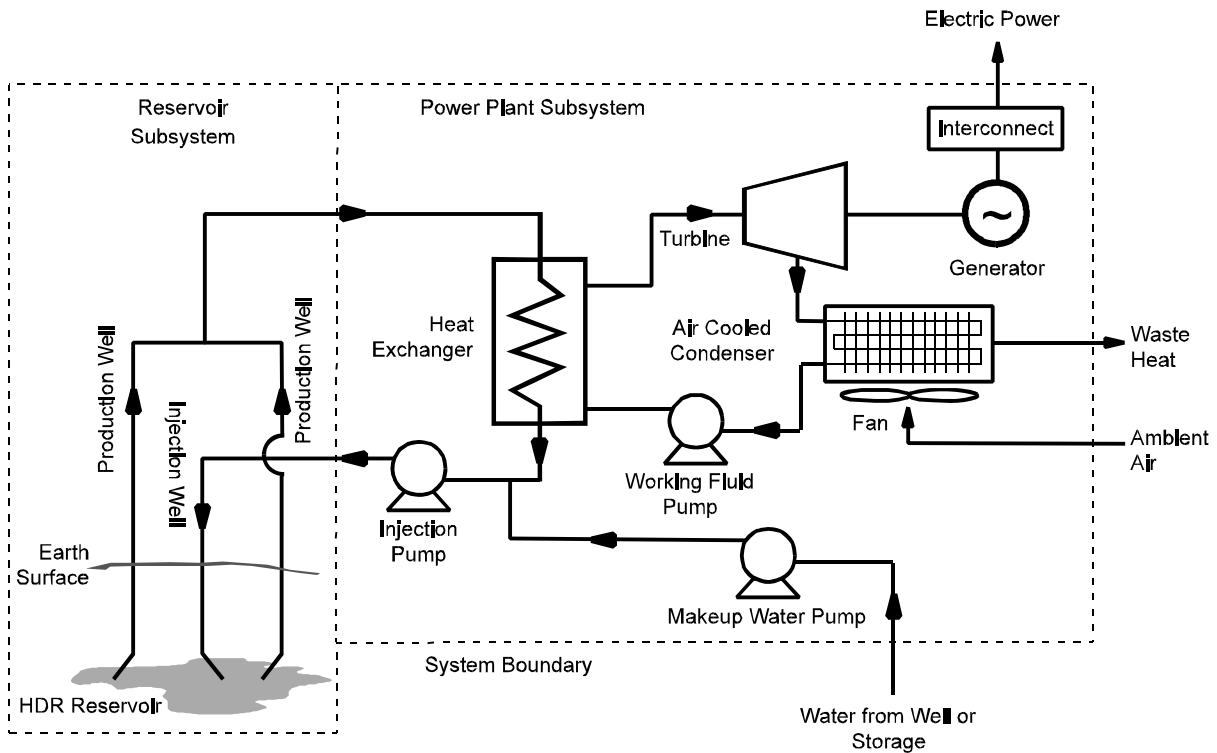

Figure 1. Hot dry rock electric power generation schematic.

system is much less mature. HDR reservoir creation and use has been demonstrated at experimental sites in the U.S., Europe, and Japan, but not on a commercial scale.

The reservoir subsystem is developed by drilling wells into hot rock about 4 kilometers deep, and connecting the wells through hydraulic fracturing. Water, from a nearby fresh water well or other source, is pumped through one or more injection wells into the reservoir, where it is heated by contact with the hot rock, and then recovered through two or more production wells.

At the surface, the power plant subsystem converts the extracted heat to electricity using commercial binary power plant technology. First, the produced hot water passes through a heat exchanger, transferring heat to a working fluid in the power plant. The working fluid is characterized by a low boiling temperature; hydrocarbons such as iso-pentane, iso-

## GEOTHERMAL HOT DRY ROCK

butane, etc. are typically used. The vaporized working fluid is expanded across a turbine to drive a generator and produce electricity. The vaporized working fluid is then condensed in a cooling system and recirculated to the heat exchanger. The hot water, upon exiting the heat exchanger, is injected back into the reservoir to collect additional heat.

The major components of a HDR system are described briefly below:

1. One, or more, hot dry rock reservoirs, created artificially by hydraulically fracturing a deep well drilled into hot, impermeable, crystalline basement rock. The hydraulic fracturing, achieved by pumping water into the well at high pressure, forces open tiny pre-existing fractures in the rock, creating a system or "cloud" of fractures that extends for tens of meters around the well. The body of rock containing the fracture system is the reservoir of heat. The fracture system provides for the heat transport medium, water, to contact a large area of the rock surface in order to absorb the heat and bring it to the surface. More than one reservoir could supply hot water to a single power plant.
2. Deep wells for production and injection of water. The wells are drilled with conventional rotary drilling technology similar to that used for drilling deep oil and gas wells. The total number of wells and the ratio of production wells to injection wells may vary. Experimental HDR systems to date have typically involved one injection well and one production well. The earliest commercial HDR systems will likely include a "triplet," two production wells for each injection well. A triplet of deep wells will support about 5 MW of power plant capacity, assuming adequate flow rates and fluid temperature. It is possible that other well configurations, such as a quadruplet (3 production wells per injection well) or a quintuplet (4 production wells per injection well) could be used. However, the cost effectiveness of using a quadruplet or quintuplet has not been established. Also, the ellipsoidal, rather than spherical, shape of the fracture pattern at Fenton Hill suggests that one production well on each side of the injection well, on the long axis of the reservoir, is the logical configuration. For these reasons, this analysis is limited to a ratio of two production wells per injection well, with earlier commercial systems limited to three wells total, and later systems using multiple triplets of wells.

The original well, from which the fracture system is created, is used for injection. Two additional nearby wells are drilled directionally to intersect the fracture system and are used as production wells. Operation of the system involves pumping water into the fracture system through the injection well, forcing it through the fracture system where it becomes heated, and recovering it through the production wells.

3. A system of microseismic instruments in shallow holes around the well that is being fractured. During the fracturing operation, this system gathers seismic data, which is used to determine the extent and the orientation of the hydraulically created fracture system. This information is then used to guide the drilling of the production wells so that they intersect the fracture system at depth. Although the HDR system, once it is completed, can operate without it, the microseismic system is included here because it is an integral part of creating the HDR reservoir and because it may be left in place to gather additional information which could be useful later in the life of the HDR system. Note that the microseismic instruments are not depicted in Figure 1.
4. A shallow water well to provide water (or other source of fresh water).
5. Surface piping, or "gathering system," to transport water between the wells and power plant.

## GEOTHERMAL HOT DRY ROCK

6. A binary power system to convert the heat in the water to electricity. This system is comprised of the following major components:
  - a. One or more turbines connected to one or more electric generators.
  - b. A heat exchange vessel to transfer heat from the hot water to a secondary working fluid with a low boiling temperature.
  - c. A heat rejection system to transfer waste heat to the atmosphere and condense the vapor exiting the turbine. A wet, or dry, cooling system can be used. The capital cost of a wet cooling system is only marginally less expensive than for a dry cooling system. However, this cost advantage is largely offset by the higher operating cost of the wet cooling system. For this reason, and since HDR sites in the U.S. are likely to be in arid areas with limited water supplies, this technology characterization is limited to a dry cooling system.
  - d. Injection pump(s) to circulate the water through the HDR reservoir.
  - e. Pumps to repressure the working fluid after it condenses and a vessel (not shown in Figure 1) for storing the working fluid.
  - f. Electrical controls and power conditioning equipment.

Additional information on binary systems can be found in the geothermal hydrothermal technology characterization and in Reference [1].

### 2.0 System Application, Benefits, and Impacts

HDR systems generate baseload electricity, but might also be used in load-following modes. An experiment conducted at Fenton Hill, New Mexico, in 1995 demonstrated that an HDR reservoir is capable of a significant, rapid increase in thermal power output on demand. In other words, an HDR electric plant could continuously generate power 24 hours a day and supply additional peak load power for a few hours each day. Los Alamos National Laboratory estimates that the thermal output could be increased by 65% for four hours each day without requiring additional wells or a larger reservoir [2]. Additional capital expense would be incurred to size the power plant and reinjection pumps to handle the increased output. However, it is possible that a price premium for the peaking power would exceed the additional costs, improving the economics of the system. An analysis of this mode of operation is not included in this study.

The Hot Dry Rock resource is important in that it is an untapped class of resource that could one day provide the nation with a significant amount of clean, reliable, economic energy. Its potential lies in its broad geographical distribution and its size. Hot dry rock is believed to exist in all geographic locations, but at different depths, depending on local geology. In the U.S., the higher grade (shallower) HDR resources exist in the western states, including Hawaii. A 1990 study conducted by the Massachusetts Institute of Technology [3] concluded the nation's high grade (gradient  $> 70^{\circ}\text{C}/\text{km}$ ) HDR resources could potentially produce 2,875 GW at an average price below 10 ¢/kWh using current technology. This is over 400 times the world's current installed geothermal electric capacity.

The HDR resource is much larger and more widespread than hydrothermal resources and is probably, therefore, the future of geothermal energy in this country. The natural progression of hydrothermal development has been to utilize the higher quality resources first. As the higher quality sites are expended and the technology matures, a minimum cost will be achieved, and the cost of developing new hydrothermal resource sites will begin increasing. The minimum cost for HDR will likely occur later than that for hydrothermal (see Figure 2), and at some point the curves will probably intersect, meaning it will become less expensive to develop HDR resources than the remaining low quality hydrothermal resources. The shape of the curves or their relationship to each other in Figure 2 are not exact. They are

## GEOTHERMAL HOT DRY ROCK

merely intended to illustrate the possibility that HDR will one day be less expensive than hydrothermal and that the historical minimum cost for hydrothermal binary will probably be less than, and occur before that, for HDR binary. It is the authors' estimate that the historical minimum cost for HDR will be approximately twice that for hydrothermal and will occur 15 to 20 years later.

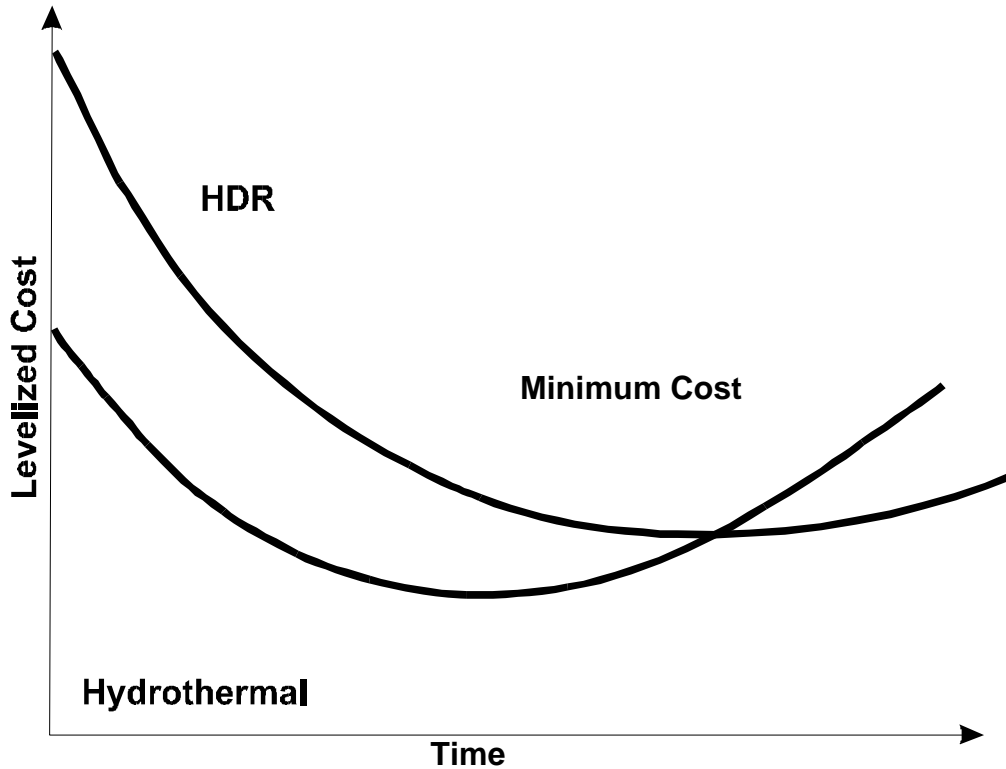

Figure 2. Hypothetical minimum cost curves for hydrothermal and HDR resources.

The environmental impacts of generating electricity from geothermal resources are benign relative to conventional power generation options. Geothermal power generation does not produce the federally regulated air contaminants commonly associated with other power generation such as sulfur dioxide, particulates, carbon monoxide, hydrocarbons, and photochemical oxidants. Some, but not all, hydrothermal fluids contain hydrogen sulfide and/or high levels of dissolved solids, such as sodium chloride. Thus, with geothermal hydrothermal power generation, the biggest environmental concerns are the possible emissions of hydrogen sulfide and contamination of fresh water supplies with geothermal brines. Hydrogen sulfide emissions are abated, when necessary, with environmental control technology, and ground water contamination is avoided through protective well completion practices. Generally, there is less possibility of adverse environmental impacts with hydrothermal binary generation than with hydrothermal flash generation because the hotter fluids used in flash plants tend to have greater concentrations of chemical contaminants than do less hot fluids typically used in binary plants. Also, in binary plants that employ dry, rather than wet, cooling systems, the geothermal fluid remains in a closed system and is never exposed to the atmosphere before it is injected back into the reservoir. See the characterization of geothermal hydrothermal technology elsewhere in this document for additional information.

## **GEOHERMAL HOT DRY ROCK**

The possible environmental impacts from a HDR binary electrical generating system are likely to be considerably less than those from a hydrothermal system employing binary technology. The water used in the HDR system is from a shallow ground water well or other source of water with low levels of dissolved solids and no hydrogen sulfide. All the water in a system with dry cooling remains in a closed loop and is never exposed to the atmosphere, limiting emissions to possible minor leaks of the working fluid around valves and pipe joints. If a wet cooling system is used, there will be some evaporation into the atmosphere with possible minor emissions, the level of which will depend on the original water quality and any chemical changes the water may experience in the reservoir. However, such emissions would be quite small compared to emissions from even the best fossil fuel electric generating technologies.

Although some water loss in the reservoir is expected with HDR systems, ground water contamination is not a concern for two reasons. First, it is probable that fresh water will be used in the system. Second, the depth and relative impermeability of the reservoir will lower the probability that the water used would migrate to shallow fresh water reservoirs.

Water consumption is a concern with HDR plants since they will likely be located in arid areas of the western U.S. Leakage around the boundaries of the reservoir may be anywhere from 5% to about 15% of the injection flow rate [4]. This would constitute water consumption of about 2 to 6 m<sup>3</sup>/MWh in a mature 30 MW system. Larger losses are possible depending on the original permeability of the reservoir rock. Larger losses could render a project uneconomic depending on the availability and cost of water.

Siting HDR plants is complicated by the need for the plant to be located at the site of the resource. This may impact the use of other resources (cultural, agricultural, mining, etc.) at the same location. It would not be unusual for HDR resources to be co-located with mining or agricultural resources.

Land use for an HDR binary plant is expected to be minimal - ranging from about 6.1 ha (15 acres) for a 5 MW plant up to 10 ha (25 acres) for a 25 MW plant. Land disruption, erosion and sedimentation, and increased levels of noise and human activity may adversely impact biological systems in the immediate vicinity of the plant and wells.

Adverse visual impacts are also possible with HDR developments and would be of concern in inhabited areas and scenic areas. However, binary geothermal power plants are compact and have a very low profile compared to other industrial facilities. A combination of the low profile, landscaping, and color camouflage was used to successfully mitigate visual impacts at the 30 MW Mammoth Lakes binary power plant in California. It is located within about three miles of one of California's major ski resorts in a county that depends heavily on tourism.

### **3.0 Technology Assumptions and Issues**

Commercially proven binary power plant technology is available for HDR application. However, critical issues remain regarding the cost and performance of the HDR reservoir. HDR reservoir creation has been successfully demonstrated, but operational experience with HDR reservoirs is insufficient to have resolved critical reservoir uncertainties regarding thermal drawdown, impedance, and water loss. High impedance to flow within experimental HDR reservoirs has resulted in much lower well production rates than in successful hydrothermal wells, as well as high parasitic power requirements for injection pumping. With less production from each well, a greater number of wells are required to supply the plant, and each well may cost 4 to 7 times that for a hydrothermal binary project because of the greater depth. Technological advances will be required to overcome this high cost of supplying hot water to the plant for HDR to become a commercially viable energy option.

## GEOTHERMAL HOT DRY ROCK

The evolution of the HDR technology is described in this document by defining three separate stages, or vintages, of technology and estimating their timing based on assumptions about R&D funding levels, government energy policy (both in the U.S. and abroad), commercial experience, and energy markets. The three vintages, Current Technology, Second Generation Technology, and Mature Technology are defined briefly below and discussed further in Section 4.1.

The Current Technology vintage is based on the best, currently available, commercial drilling and power plant technologies, and experience at Fenton Hill, New Mexico, where the technical feasibility of HDR power generation was demonstrated by Los Alamos National Laboratory and DOE in the late 1970s. It is based on a single triplet of wells (one injection and two production wells). The power plant performance and cost are based on the Next Generation Geothermal Power Plant (NGGPP) study [5] published by the Electric Power Research Institute in 1996. Drilling costs are based on actual deep geothermal wells drilled recently in the western U.S. Reservoir operational parameters, thermal drawdown, and flow impedance were estimated by HDR scientists at Los Alamos National Laboratory [6]. The first commercial application of HDR systems will probably occur in about 6 to 20 years based on current technology and research levels, depending on governmental policies and market conditions. Experience from several years of operation at several commercial sites will be necessary to achieve Second Generation Technology.

The Second Generation Technology includes about 40% of the total improvement required to go from Current to Mature Technology. It will depend on technology improvements gained through both R&D and experience with the first few commercial HDR projects. The Second Generation Technology will probably be achieved no earlier than about 2015. Beginning in 2020, confidence in Second Generation Technology and lower costs will lead to slightly larger plants with two triplets of wells.

The Mature Technology is that for which further improvements will have only minor effect on the cost of power. It will depend on further improvements in power plant and deep well technologies, as well as additional experience gained at 15 to 20 commercial HDR operations. It will incorporate larger plants supplied by 4 or more triplets of wells. Mature Technology will probably not be achieved before about 2030.

Achieving these levels of technology in this time frame assumes that improvements will result from both R&D efforts and experience with commercial HDR plants as they are developed and operated. The progress of the technology will depend on complex interactions involving the levels of funding for drilling R&D, as well as more HDR-specific R&D in several countries, supply and demand in electricity markets, supply and demand in petroleum markets (which greatly influence drilling costs and funding of drilling research), public policy (especially regarding energy and the environment), and progress in other electric supply technologies.

Assumptions concerning related research include:

- HDR research efforts in Japan and Europe will continue.
- A significant HDR research program will be renewed in the U.S. at a funding level of \$7 to \$10 million annually by the year 2000.
- The U.S. will heavily fund R&D in deep drilling and well completion, resulting in a significant reduction in the cost of deep wells over the next 30 years.

Electricity demand is assumed to grow faster than supply, creating a positive atmosphere for further development of HDR technology. Petroleum markets are assumed to encourage private industry and government agencies to support significant levels of research in well drilling and completion and that the relationship between supply and demand for drilling services does not increase drilling costs significantly.

## GEOTHERMAL HOT DRY ROCK

Energy policy assumptions are that the U.S. and other governments will encourage the earliest commercial development of HDR through various incentives similar to those used to encourage the development of hydrothermal power generation in the U.S.

As with hydrothermal power generation, HDR performance and economics depend heavily on the physical characteristics of the reservoir. This characterization assumes physical reservoir parameters believed characteristic of fairly high grade HDR resources in the Basin and Range geologic province (see Figure 3). This area is representative of a large portion of the higher grade domestic HDR resource, as measured by geothermal gradient (the increase in temperature with each unit increase of depth). Although the global average gradient is about 25°C/km, some areas have much higher gradients [3]. A higher gradient translates into improved HDR economics because the wells can be shallower. For this reason, the first few commercial HDR projects will likely be located where gradients are 80°C/km or better. A gradient of 65°C/km is assumed for this analysis in order to represent a larger portion of the HDR resource. This results in an average formation temperature of 275 °C (527°F) at a depth of 4,000 meters.

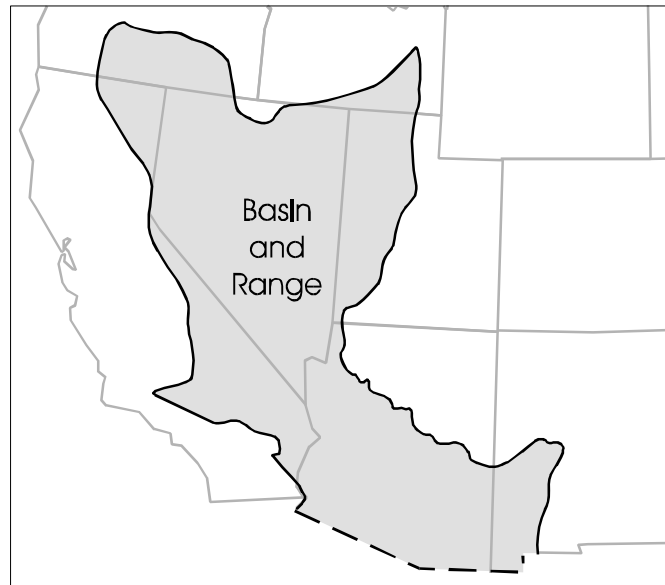

Figure 3. Basin and Range geologic province.

### 4.0 Performance and Cost

Table 1 summarizes the performance and cost indicators for the geothermal hot dry rock system being characterized in this report. These indicators, although finalized in this report, have evolved over several Technology Characterization exercises, beginning at Sandia National Laboratory in 1993 [7].

Table 1. Performance and cost indicators.

INDICATOR NAME	UNITS	Base Case		2000		2005		2010		2020		2030	
		1997	+/-%		+/-%		+/-%		+/-%		+/-%		+/-%
Plant Size	MW	6		6.40		6.51		6.75		17.91		35.81	
Injection Pump Parasitic	MW	1.20		1.20		1.20		1.20		3.12		6.24	
Net Plant Size	MW	5.06		5.20		5.31		5.55		14.78		29.57	
Performance													
Geothermal Gradient	°C/km	65		65		65		65		65		65	
Well Depth	km	4		4		4		4		4		4	
Reservoir Volume	10 <sup>6</sup> m <sup>3</sup>	99		99		99		99		198		396	
Number of Well Triplets		1		1		1		1		2		4	
Triplet Flow Rate	1000 kg/hr	223.6	+0/-20	223.6	+0/-20	223.6	+0/-20	223.6	+0/-20	290.7	+0/-38	290.7	+0/-38
Net Brine Effectiveness	Wh/kg	28		28.6		29.12		30.12		30.8		30.8	
Capacity Factor	%	80		81		82		83		85		90	
Annual Energy Production	10 <sup>3</sup> MWh	35.45		36.85		38.14		40.36		110.06		233.07	
Capital Cost													
Exploration	\$/kW	395	10	385	10	377	+12/-10	360	+12/-8	135	+15/-6	68	+20/-6
Siting and Licensing		64		64		64		64		64		64	
Land (@ \$4,942/hectare)		5.93		5.78		5.65		5.40		2.71		1.69	
Field Costs													
Wells		2,076	+10/-10	1,878	+15/-8	1,631	+20/-5	1,384	+25/-0	945	+30/-0	639	+40/-0
Fracturing		611	+10/-5	595	+10/-5	553	+10/-5	501	+12/-3	406	+15/-0	391	+20/-0
Gathering System		99		91		81		71		58		55	
Fresh Water System		172		161		146		132		110		85	
Injection Pumps		140		137		134		128		115		115	
Total Field Cost		3,098		2,861		2,545		2,216		1,634		1,286	
Plant Cost		1,847	5	1,751	+7/-5	1,656	+10/-5	1,558	+15/-5	1,330	+20/-5	1,163	+30/-5
Project Cost		109		109		109		109		109		109	
Total Capital Requirement	\$/kW	5,519	+23/-6	5,176	+25/-6	4,756	+29/-5	4,312	+34/-4	3,276	+47/-3	2,692	+51/-3

Notes:

1. The columns for +/-% refer to the uncertainty associated with a given estimate.
2. Construction period is 2 years, with 35% of capital cost incurred in year 1 and 65% incurred in year 2.
3. Totals may be slightly off due to rounding.
4. Although, no commercial HDR systems have been built as of 1997, the base case cost (1996) is an estimate of what a commercial HDR system would have cost in 1996 based on commercial binary plants at hydrothermal sites and actual deep geothermal wells recently drilled in Nevada.



Table 1. Performance and cost indicators.(cont.)

INDICATOR NAME	UNITS	Base Case 1997		2000		2005		2010		2020		2030	
			+/-%		+/-%		+/-%		+/-%		+/-%		+/-%
Plant Size	MW	6		6.40		6.51		6.75		17.91		35.81	
Operation and Maintenance Cost													
Power Plant O&M	\$/kW/yr	50		45		37		33		30		30	
Daily Field O&M	\$/kW/yr	35		34		33		32		30		28	
Well Repair	\$/kW/yr	134		128		121		114		103		94	
Total Operating Costs	\$/kW/yr	219		207		191		179		163		152	

Notes:

1. The columns for +/-% refer to the uncertainty associated with a given estimate.
2. Totals may be slightly off due to rounding.
3. Although, no commercial HDR systems have been built as of 1997, the base case cost (1996) is an estimate of what a commercial HDR system would have cost in 1996 based on commercial binary plants at hydrothermal sites and actual deep geothermal wells recently drilled in Nevada.

# GEOHERMAL HOT DRY ROCK

## 4.1 Evolution Overview

The evolution of the three HDR technology vintages is discussed below. The evolution of the technology between these stages and the uncertainty involved is evident in Table 1 and accompanying discussion in Section 4.2.

**Current Technology:** The Current Technology system is defined as the reservoir and power plant system that could have been built in the period 1996-1997. This relies heavily on the experience which the U.S. Department of Energy gained creating and testing the Phase I & II HDR reservoirs at Fenton Hill, NM. However, it is based on a triplet well configuration (two production wells and one injection well), compared to the doublet (one production well and one injection well) configuration at Fenton Hill. It also assumes that the HDR reservoir could be expanded to about six times the size of the current Fenton Hill reservoir and the heat could be swept from the reservoir by a single well triplet.

**Second Generation Technology:** The Second Generation Technology is similar to Current Technology in that it is a small plant utilizing a single triplet of wells. It assumes: (a) improvements of conversion (power plant) technology (which are expected to arise from R&D and demonstrations outside of the HDR Research Program), (b) that the HDR wells and fractures can be made considerably less expensive than currently, (c) that the reservoir volume can be expanded to about 1.3 times that assumed in the Base Case, and (d) that improved techniques for creating the reservoir result in a triplet flow rate 1.3 times that of the base case. It is estimated that the earliest such systems could be commercially available would be about 2015. This estimate is based largely on the assumption that the European HDR research program will be successful in its plan to complete a Scientific Pilot Plant by the year 2000 and an Industrial Prototype plant by the year 2002 [8]. After Second Generation Technology becomes available in 2015, it will be applied with multiple well triplets in the year 2020.

**Mature Technology:** This system is defined as that for which further improvements would have only insignificant impacts on the cost of power. It consists of a larger plant with 4 triplets of wells. It assumes: (a) improvements in well drilling and completion technology radical enough to reduce the cost of the HDR wells to 50 percent of their cost in the Base Case, (b) some additional incremental modest improvements in other aspects of the technology, (c) experiential improvements gained from 15 to 20 years of operations at 15 to 20 commercial HDR plants, and (d) a cost reduction compared to the Current Technology due to economies of scale achieved with a larger plant and 4 well triplets. It is estimated that the earliest this system could be achieved would be in about 30 to 50 years.

## 4.2 Performance and Cost Discussion

The estimated performance and cost through the year 2030 are presented in Table 1, along with uncertainty estimates of some of the key parameters. The Current and Mature Technology scenarios are represented in the columns for 1997 and 2030. Second Generation Technology is projected for 2015, such that projections in the 2010 and 2020 columns bracket the Second Generation Technology.

The cost of developing HDR geothermal resources is greater than that for hydrothermal binary plants although the technology employed is essentially the same. This is due to several factors. First, the greater unit cost of the binary power plant for HDR resources is due to scale (hydrothermal binary plant costs are based on a 50 MW plant). Second, HDR wells are much deeper than typical hydrothermal wells, making them 3 to 5 times more expensive. Finally, the estimated flow rate per HDR well is only about a third of that of a good hydrothermal well, requiring more wells for a given level of power output.

## GEOHERMAL HOT DRY ROCK

The performance and cost estimates are based on a number of technical assumptions. The analysis assumes commercial binary power plant technology with dry cooling, similar to that used at numerous hydrothermal sites in the U.S. and elsewhere. The injected water will be heated to the average formation temperature but will lose about 24°C (75°F) by conduction through the well as it travels to the surface. This results in an initial plant inlet temperature of 251°C (484°F) for the geothermal fluid. However, for design conservatism, the plant is designed for and operated at an inlet temperature of 226°C (439°F).

Based on this temperature, a flow rate of about 224,000 kg per hour is required to support a small power plant, and it is estimated that a reservoir of 98 million m<sup>3</sup> will contain sufficient heat to operate the plant for 20, or more, years. These parameters were used at Kansas State University, in GEOCRACK, to simulate the thermodynamic response of the reservoir. GEOCRACK is a discrete element hot dry rock reservoir simulator that accounts for rock deformation, heat transfer, and fluid flow [6]. The results, presented in Figure 4, indicate the timing of the thermal

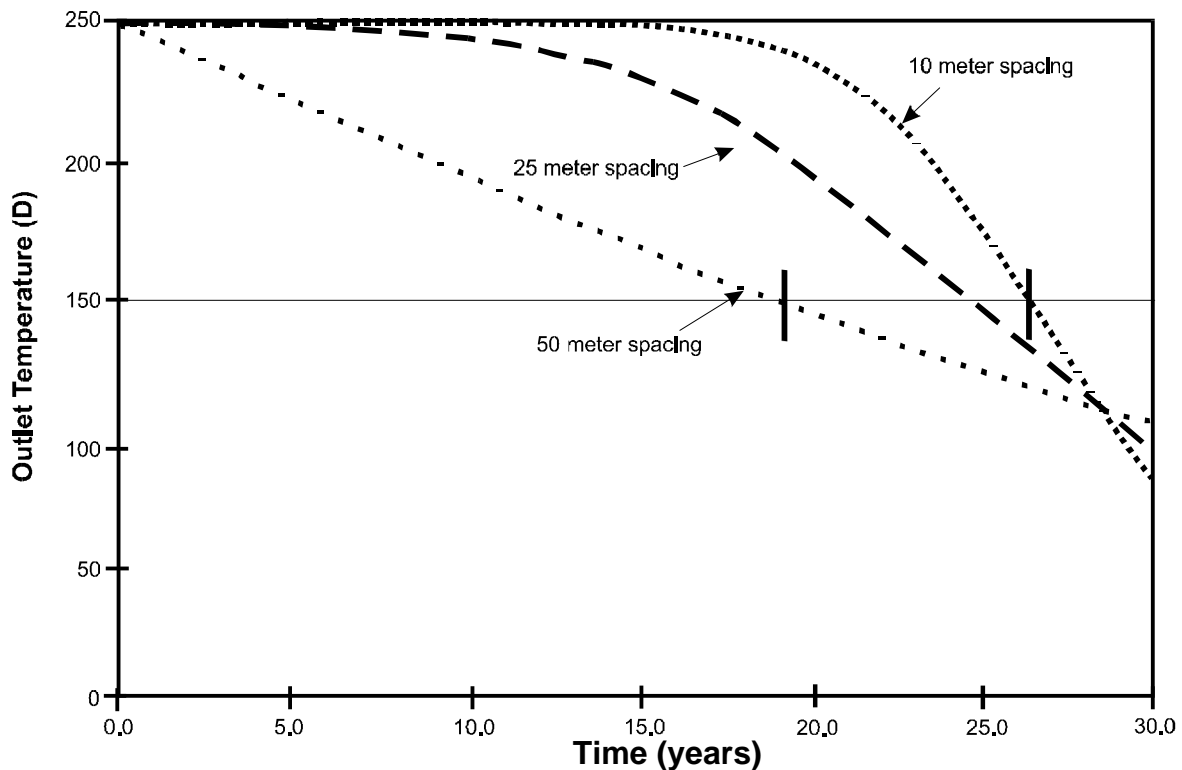

Figure 4. Results of GEOCRACK HDR reservoir simulation.

drawdown in the reservoir depends primarily on the distribution of the fracture joints through which the fluid flows. With narrow joint spacing (10 meters or less), the temperature will remain fairly flat for the first 18 to 20 years, and then drop fairly rapidly over the following 8 or 10 years. For this analysis, it is assumed the temperature will remain constant for the first twenty years and then drop by 20 0°C (392°F) over the following ten years.

Other key technical assumptions include:

## GEOTHERMAL HOT DRY ROCK

- Thermal dilation of the reservoir fractures will contribute to achieving projected flow rates
- Reservoir injection pressure is 3,000 psi (20,684 kPa) and reservoir production pressure is 1,000 psi (6,895 kPa)
- Injection pump efficiency is 80% and pump motor efficiency is 95%.
- Well depth is 4,000 meters

Current Technology through Second Generation Technology employs a single triplet of wells. The technology in the year 2020 employs two triplets, and the Mature Technology employs 4 triplets.

The discussion below describes the basis for and calculations of the numbers in Table 1. The Second Generation and Mature technologies are referred to as the 2015 and 2030 technologies, respectively.

Net Brine Effectiveness (NBE) and Power Output: The net brine effectiveness is derived from Figure 5-2 of Reference [5]. For a plant inlet temperature of 226°C (439°F), the specific output is approximately 11.5 kW/1000 lb/hr brine. The parasitic power for injection and production pumps is about 9.8% of the net power [5]. Therefore, adjusting for injection and production pumping parasitic power yields:

$$\begin{aligned} \text{specific output} &= 11.5 / (1 - 0.098) = 12.75 \text{ kW/1,000 lb/hr brine:} \\ &= 28 \text{ Wh/kg brine} \end{aligned}$$

It is estimated by the authors that R&D can improve the NBE effectiveness in this temperature range by about 10%, and that this will be achieved incrementally by 2015.

System power output is the product of the net brine effectiveness, the number of well triplets, and the brine flow rate per well triplet. The net power output is the system output less the parasitic power required for injection. Power plant costs are based on the system power output.

Injection Parasitic Power: An injection pressure of 20,684 kPa (3,000 psi) and a production backpressure of 6,895 kPa (1,000 psi) is anticipated to maintain the desired pressure differential across the reservoir [6]. The plant outlet pressure is estimated to be 6,205 kPa (900 psi). To achieve the injection pressure, the injection pump must supply 20,684 - 6,205 = 14,479 kPa (2,100 psi). The required work rate to obtain a 223,600 kg/hr (1,000-gpm) flow rate, given a pump efficiency of 0.8 and a pump motor efficiency of 0.95, is given by

$$P_p = [(1,000 \text{ gal/min})(2,100 \text{ lb/in}^2)] / 1,714 / 0.8 / 0.95 = 1,612 \text{ hp} * 0.747 \text{ kW/hp} = 1,202 \text{ kW}$$

Capacity Factor: Although capacity factors for many hydrothermal binary plants are over 90% (see the characterization of geothermal hydrothermal technology elsewhere in this document), the capacity factor for the HDR Current Technology system is limited to 80% to reflect the fact that HDR wells will be too expensive to have any spare production or injection wells as is the practice with hydrothermal binary plants. Without spare wells and only one triplet, production will drop by 50% when one of the production wells is under repair, and by 100% when the injection well is under repair. The capacity factor is increased over time to reflect improved well completion technology and reduced time required for well repairs due to operational experience. Also, the capacity factor increases with increasing numbers of well triplets because a smaller proportion of the total flow will be suspended when a single well is shut in for maintenance.

Exploration Cost: Exploration costs for the Current Technology are estimated by the authors to be \$2 million based on their knowledge of hydrothermal exploration. Factors of 0.97, 0.94, and 0.90 are applied to the 1997 exploration cost for the 2005, 2010, and 2015 technologies, respectively. Factors of 0.85 and 0.80 are applied to the 1997 cost to reflect further technology cost reductions in 2020 and 2030, respectively. These estimated

## GEOTHERMAL HOT DRY ROCK

cost reductions are based on the assumptions that both HDR R&D and HDR commercial experience will lead to improved exploration technology for HDR resources. A factor of 1.5 is applied to the 1997 cost to account for the economy of scale achieved in doubling the size of the field for the 2020 technology. A factor of 2.5 is applied to the 1997 cost to account for the economy of scale achieved in quadrupling the size of the field for the 2030 technology. These economy of scale factors are arbitrary estimates made by the authors.

Land Cost: Estimated at \$4,942/ ha (\$2,000/acre) and requirements of 6.1 ha (15 acres) for the plant and one well triplet, 8.1 ha (20 acres) for the plant and 2 well triplets (year 2020), and 10 ha (25 acres) for the plant and 4 well triplets (year 2030).

Well Cost: The 1997 costs of \$3.5 million per well are estimated by an experienced geothermal drilling engineer based on the costs of recently drilled deep (average depth of 3261 m, or 10,700 feet) geothermal wells in the Basin and Range [6]. The \$3.5 million includes all costs for drilling and completing a 4,000 m (13,124 ft) well. Well costs for the 2030 technology are estimated to be only 50% of those for the Current Technology. This is the authors' estimate of the greatest possible reduction in drilling costs that might be reasonably projected. It is premised on 4 propositions: (1) Sandia National Laboratory states that "Advanced technology development...has the potential for reducing geothermal drilling costs by at least 30% [9]; (2) New technology is capable of providing radical reductions in drilling cost as evidenced by Unocal's reference to its Thailand operations "Drillers learned to drill wells for 75% less the cost of wells in 1980" due to new technology [10]; (3) The Massachusetts Institute of Technology's National Advanced Drilling and Excavation Technology Institute has as its goal a 50% reduction in the cost of drilling [11]; and (4) In a 1994 study of future drilling technology, the National Research Council, an arm of the National Academy of Sciences, concluded "that revolutionary advances are within reach" and that "Rapid innovation in microelectronics and other fields of computer science and miniaturization technology holds the prospect for greater improvements - even revolutionary breakthroughs - in these (drilling) systems." [12]

For the 2015 well cost, a factor of 0.80 is applied to the 1997 cost of \$3.5 million per well to reflect cumulative incremental drilling and completion technology improvements. This results in a cost of \$2.8 million per well. For the 2030 cost, as stated above, a factor of 0.5 is applied to the 1997 cost of \$3.5 million per well to reflect further drilling and completion technology improvements. This results in a cost of \$1.75 million per well. Factors of 0.95 and 0.90 are applied to well costs in 2020 and 2030, respectively, to reflect economies of drilling multiple wells at the same location.

Fracturing Cost: The Current Technology fracturing costs are based on experience at Fenton Hill and are estimated to be \$3.09 million. The authors estimate that experience creating HDR reservoirs will result in improved techniques by 2015 that will intensify fracturing sufficiently to gain 30% more flow through the same size reservoir with a proportional increase in the cost. This increased cost is offset partially by technology improvements (expected from the combination of HDR R&D and experience with commercial HDR applications) accounted for by applying factors of 0.95, 0.90, and 0.85 to the 1997 costs to reflect costs in 2005, 2010, and 2015, respectively. Thus, the 2015 cost of fracturing is  $0.85 \times 1.3 \times \$3.09$  million, or 545 \$/kW. Further technology improvements (expected from the combination of HDR R&D and experience with commercial HDR applications) will reduce the base cost by 17% and 20% in 2020 and 2030, respectively. Factors of 0.95 and 0.90 are applied to the fracturing costs in 2020 and 2030, respectively, to reflect economies of scale.

Fresh Water System Cost: The Current Technology cost is based on the cost of a fresh water well [4]. The cost remains unchanged through 2015. By 2030, it is reduced by 20% to reflect improved drilling technology. Factors of 0.95 and 0.90 are applied to the water system costs in 2020 and 2030, respectively, to reflect discounts for drilling multiple fresh water wells at the same location.

## GEOTHERMAL HOT DRY ROCK

Injection Pumps Cost: Working from cost relationships adapted from Armstead and Tester [13], the installed cost of the injection pump and its electric motor drive is estimated to be \$710k. A factor of 1.2 is applied to this cost for 2015 to reflect the 30% increase in flow (the relationship between pump cost and flow rate is not linear). For 2030, a factor of 0.9 is applied to the 2015 cost to reflect improved technology. Factors of 0.97 and 0.95 are applied to the injection pump costs in 2020 and 2030, respectively, to reflect discounts for buying multiple pumps.

Power Plant Cost: The 1997 binary power plant cost is derived from cost data in Reference [5] for hydrothermal binary power plants. The plant cost is adjusted to account for the fact that downhole production pumps are not necessary with the HDR system. It is also adjusted to remove the embedded cost for injection pumps since the HDR system will require larger injection pumps (which are included in the field costs in the HDR TC).

The differences in the unit costs of the binary HDR plant and the binary hydrothermal plant (see geothermal hydrothermal technology characterization) are attributable to three factors. The cost adjustments mentioned in the previous paragraph and the higher inlet temperature for the HDR plant make it slightly less expensive than the hydrothermal binary. Also, it is assumed that there is an economy of scale inherent in the 50 MW binary hydrothermal plant cost in Reference [5]. A scaling factor of 0.9 is used to adjust the 50 MW cost to the appropriate size in each given year. For example, for the Current Technology:

$$6.26 \text{ MW unit cost} = 50 \text{ MW unit cost} * (6.26/50)^{0.9}/(6.26/50) = 50 \text{ MW unit cost} * 1.2309$$

The unit cost for the HDR binary plant is derived from Reference [5] cost data in the following manner:

Field Cost (from Table 6-3, Reference [5], Vale resource):

production wells	\$24,705,882
injection wells	\$10,500,000
gathering system	<u>\$ 1,333,187</u>
	\$36,539,069 or 731 \$/kW

Calculation of plant costs (1993 \$/kW):

Total Project Cost	2,125	Figure 5-4 of 2/96 NGGPP
Field Cost	-731	Table 6-3 of 2/96 NGGPP, Vale resource
Injection Pumps	- 3	cost estimate
Production Pumps	- 38	cost estimate
Electrical Interconnect	<u>+20</u>	cost estimate
	1,373	Power plant cost

Adjust to 1997 dollars:	1,500 \$/kW
Extract economy of scale:	1.2309*1,500 = 1,847 \$/kW

Binary power plant cost reductions due to technology improvements are estimated to total 25% over the entire period. This is allocated by applying the factors 0.95, 0.90, 0.85, 0.825, 0.80 and 0.75 in the years 2000, 2005, 2010, 2015, 2020, and 2030, respectively. This is based on reference [5], as well as the authors' combined 25 years of experience analyzing geothermal technology and R&D. The reader may refer to the characterization of hydrothermal geothermal for further discussion.

Total Capital Cost: The total project unit cost is the sum of the individual costs listed above plus a project cost of \$109/kW [5]. The project cost covers the owner's administrative costs and plant start-up costs.

## **GEOHERMAL HOT DRY ROCK**

Operation and Maintenance Costs: HDR power plant O&M costs are estimated to be equal to those of a hydrothermal binary power plant. The reader is referred to the section on hydrothermal binary for a discussion of binary power plant O&M.

Well field O&M cost components are taken from Reference [4] and adjusted to 1997 dollars. Daily operation and maintenance will cost about \$218k/yr. This cost assumes one person's labor plus maintenance and repair contracts. Additionally, hydrothermal wells require work-over and clean-out every one to two years depending primarily on brine chemistry. It should be possible to maintain a certain amount of control over the chemistry in HDR wells, thus reducing the maintenance schedule when compared to hydrothermal wells. On this basis, it is assumed that each HDR well will need a work-over every three years; thus the site average will be one well per year.

Clean-out and work-over will require a work-over rig for about 15 days at \$11k/day (\$165k). Mobilization and demobilization of the rig will cost another \$109k. Materials for work-over (wellhead, cement, casing, etc.) are estimated to cost between \$164k and \$545k. Using a mid-range value of \$350 for materials yields an estimate of \$624k for work-over. Combining work-over and daily maintenance, well field O&M is estimated to cost \$842k/yr.

Uncertainty: Considerable uncertainty is inherent in projecting future costs and technology improvements. This uncertainty is estimated subjectively with plus/minus percentage figures for key parameters in Table 1. The projections are for the very best technology that it is believed could be reasonably achieved, and so the estimates for uncertainty are weighted heavily toward lower performance, less improvement and less reduction in cost. The most uncertain estimates are the flow rate per triplet of wells and the 50% reduction in the cost of deep wells. Therefore, the uncertainty estimates for the flow rate are based on 20% less flow for the Current Technology and failure to achieve the 30% increase in flow rate for the Second Generation Technology. Also, the uncertainty estimate for the well cost is based on achieving only a 30%, rather than 50%, reduction in the cost of wells. These two major uncertainties and other less significant uncertainties combine to result in the uncertainty for the total capital requirement. The uncertainty for the total capital requirement in the year 2030 is that it may cost 3% less than or 51% more than the projected \$2,977 per installed kW of capacity.

### **5.0 Land, Water, and Critical Materials Requirements**

Land Requirement: As shown in Table 2, the land requirement is assumed to be similar to those for hydrothermal electric systems. It includes the land occupancy for the power plant and surface disturbances due to wells and pipelines. Roads to the site are not included. The unit land requirements decrease with larger plants.

Water Consumption: Water is required for drilling the deep HDR wells, and for fracturing the HDR reservoir rock. The amounts required are not quantified here. The system water "makeup" well would be drilled before the HDR deep wells are drilled; thus all water needed by the system except for that needed to drill the water well would come from that well.

The power plant is designed with dry cooling towers, so there is no major water consumption by the power plant per se. This is a conscious decision in the system design configuration based on the premise that HDR systems will most likely be developed at arid locations in the western U.S.

## GEOTHERMAL HOT DRY ROCK

Table 2. Resource requirements.

Indicator Name	Units	Current Technology		
		1997	2020	2030
Net Plant Size	MW	5.06	14.78	29.57
Land Requirement	ha/MW	1.2	.55	.34
	ha	6.1	8.1	10.1
Water				
Injection Flow Rate	m <sup>3</sup> /MWh	44.87	40.82	39.93
Estimated Water Consumption	m <sup>3</sup> /MWh	2.24-6.73	2.04-6.12	2.0-5.99

Notes:

1. Water consumption is based on the rate of 5% to 15% of the injection rate.
2. The year 2000-2010 cases are not included in Table 2 because they are all single well triplet plants similar to the 1997 case

Almost all of the water consumption during system operation will be for water that enters and remains in the HDR reservoir. Water loss during initial system operation is estimated to be 5% to 15% of the volume pumped through the fracture system [4]. However, these estimates of water loss are based on limited testing of other than commercial-size systems and are uncertain. Actual losses could be more or less depending on the original permeability of the reservoir rock. It is estimated by a HDR scientist at Los Alamos National Laboratory that in a commercial system the water loss would become negligible with time [14], on the order of one to two percent of HDR reservoir circulation flow rate.

Energy, Feedstock, and Critical Materials: Electricity is required for startup from cold shutdown. The capacity required is some major fraction of the core-plant cycle parasitic power needs (e.g., for binary fluid circulation pumps and cooling fans) plus the power needed to run the HDR-loop high-pressure injection pumps.

Organic or other working fluid is needed to charge the binary power module, and replace small leakage losses during operation. There are essentially no special materials in these systems.



## GEOTHERMAL HOT DRY ROCK

### 6.0 References

1. Elovic, A., "Advances in Binary Organic Rankine Cycle Technology," Geothermal Resources Council Transactions, p. 511, 1994.
2. Brown, D.W., "The Geothermal Analog of Pumped Storage for Electrical Demand Load Following." Proceedings of the 31st Intersociety Energy Conversion Engineering Conference, Vol. 3, August 1996.
3. Tester, J.W., and H. J. Herzog, Economic Predictions for Heat Mining: A Review and Analysis of Hot Dry Rock (HDR) Geothermal Energy Technology, Energy Laboratory, Massachusetts Institute of Technology, Cambridge, Massachusetts: July 1990. Report MIT-EL 90-001.
4. Pierce, K.G., and B.J. Livesay, "An Estimate of the Cost of Electricity Production from Hot-Dry Rock," Geothermal Resources Council Bulletin. Vol. 22, No. 8 (September 1993).
5. Brugman, J.M., M. Hattar, K. Nichols, and Y. Esaki, Next Generation Geothermal Power Plants, Electric Power Research Institute: February 1996. Report EPRI TR-106223.
6. Brown, D., and D. Duchane, Los Alamos National Laboratory, personal communication to Lynn McLarty on November 5, 1996.
7. The authors are indebted to an earlier, unpublished HDR technology characterization study conducted by Kenneth G. Pierce at Sandia National Laboratory, 1993.
8. Baumgartner, J., R. Baria, A. Gerard, and J. Garnish, "A Scientific Pilot Plant: The Next Phase of the Development of HDR Technology in Europe." Proceedings of the 3rd International HDR Forum, Santa Fe, New Mexico (May 13-16, 1996).
9. Glowka, D.A., "Geothermal Drilling Research Overview," Proceedings of the Geothermal Program Review XIV, April 1996, p. 217. U.S. Department of Energy report DOE/EE-0106.
10. Hulce, D.L., "Geothermal Energy - Business Challenge and Technology Response," Proceedings of the Geothermal Program Review XIV, p. 21 (April 1996). U.S. Department of Energy report DOE/EE-0106.
11. "National Advanced Drilling and Excavation Technologies Program and Institute," Proceedings of the Geothermal Program Review XIV, p. 243 (April 1996). U.S. Department of Energy, Report DOE/EE-0106. U.S. Department of Energy report DOE/EE-0106.
12. Drilling and Excavation Technologies for the Future, National Research Council, National Academy Press, Washington, D.C., 1994.
13. Armstead, H.C.H, and J. Tester, Heat Mining: A New Source of Energy, E. & F.N. Spon Ltd, University Press, London, 1987.
14. Duchane, D.V., Hot Dry Rock Heat Mining Geothermal Energy Development Program, Los Alamos National Laboratory: FY1991 Annual Report, January 1992. Report LA-UR-92-870.

# OVERVIEW OF PHOTOVOLTAIC TECHNOLOGIES

## Introduction

Solar photovoltaic modules, called “photovoltaics” or “PV”, are solid-state semiconductor devices with no moving parts that convert sunlight into direct-current electricity. Although based on science that began with Alexandre Edmond Becquerel’s discovery of light-induced voltage in electrolytic cells over 150 years ago, significant development really began following Bell Labs’ invention of the silicon solar cell in 1954. PV’s first major application was to power man-made earth satellites in the late 1950s, an application where simplicity and reliability were paramount and cost was nearly ignored. Enormous progress in PV performance and cost reduction, driven at first by the U.S. space program’s needs, has been made over the last 40-plus years. Since the early 1970s, private/public sector collaborative efforts in the U.S., Europe, and Japan have been the primary technology drivers. Today, annual global module production is over 100 MW, which roughly translates into a \$1 billion/year business. In addition to PV’s ongoing use in space, its present-day cost and performance also make it suitable for many grid-isolated applications in both developed and developing parts of the world, and the technology stands on the threshold of major energy-significant applications worldwide.

PV enjoys so many advantages that, as its comparatively high initial cost is brought down another order of magnitude, it is very easy to imagine its becoming nearly ubiquitous late in the 21<sup>st</sup> century. PV would then likely be employed on many scales in vastly differing environments, from microscopic cells integrated into and powering diamond-based optoelectronic devices in kilometers-deep wells to 100-MW or larger ‘central station’ generating plants covering square kilometers on the earth’s surface and in space. The technical and economic driving forces favoring PV’s use in these widely diverse applications will be equally diverse. However, common among them will be PV’s durability, high efficiency, low cost, and lack of moving parts, which combine to give an economic power source with minimum maintenance and unmatched reliability. In short, PV’s simplicity, versatility, reliability, low environmental impact, and—ultimately—low cost, should help it to become an important source of economical premium-quality power within the next 50 years.

It is easy to foresee PV’s 21<sup>st</sup>-century preeminence, but the task of this chapter is a difficult one of accurately predicting PV’s development trajectory toward that time. The three applications described here (Residential PV; Utility-Scale, Flat-Plate Thin Film PV; and Concentrating PV) illustrate highly feasible elements of that trajectory. These applications likely will blossom at different rates and may not all develop as forecasted. Furthermore, they are not the only major applications likely to emerge. Nevertheless, the three scenarios presented serve to give a sense of the time scale in which PV is likely to evolve from its present-day state, to the pervasive low-priced appliance of the latter half of the next century. During the time period covered by these characterizations, PV will evolve from a technology serving niche markets, to one entering and then playing an important and growing role in the world’s energy markets. Up to 10% of U.S. capacity could be PV by 2030, and significant PV will be used worldwide as global demand for electricity grows.

## Economic Evolution

Empirical progress in manufacturing processes is frequently displayed by means of a “learning” or “experience” curve. Conventionally, such curves are plotted using logarithmic axes, to show per-unit cost versus cumulative production volume. Most often, such a plot will produce a straight line over a very large range of actual production volumes and unit costs. The slope of that line, expressed as the percent of cost remaining after each doubling in volume, is called the “progress ratio.” (Since a progress ratio of 100% would represent no learning—i.e., zero cost reduction—it would perhaps be better called a “lack-of-progress ratio.”) Most manufactured goods are found to yield progress ratios between 70% and 90%, but there appears to be no generally applicable rule for assigning *a priori* expectations of progress ratios for a given process.

## OVERVIEW OF PHOTOVOLTAIC TECHNOLOGIES

Figure 1 shows the experience curve over the past 20-some years for PV module prices versus total sales. Price and total sales are used as proxies for cost and manufactured volume because the actual cost and production information for the entire industry is not available. Note that, although the plotted data comprise a number of technologies, the dominant technology—crystalline silicon—has set the pace for the price-volume relation. Therefore, this figure most closely represents an experience curve for crystalline silicon PV, and this curve was used within the Technology Characterization for Residential PV systems. The 82% value falls within the range typical for manufactured goods, and the projections of crystalline-silicon module sales and prices provided within that TC are further supported by a “bottom up” analysis of the industry.

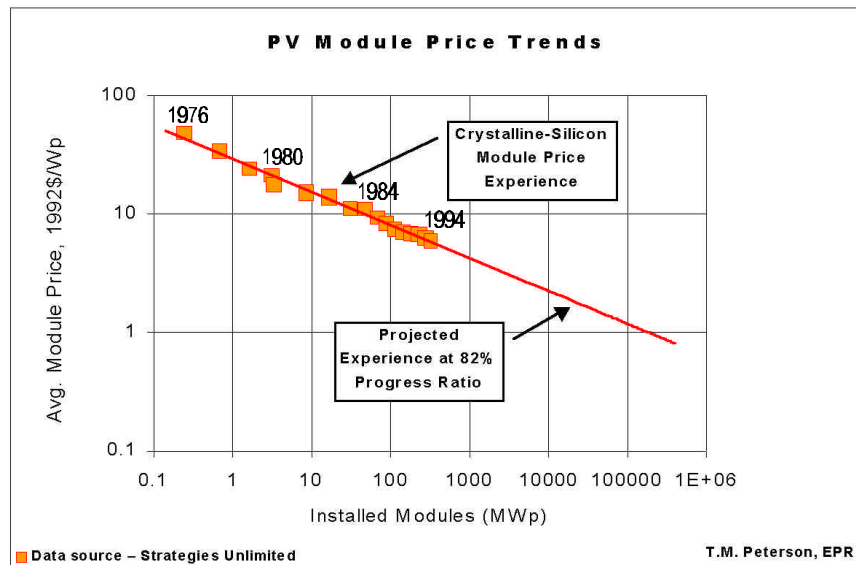

Figure 1. Learning curve for crystalline-silicon PV.

A major departure from the historical trend could be caused by emergence of a fundamentally new technology where the learning process would need to begin anew. Both thin-film and concentrator PV are likely candidates for just such a fundamental technology shift. Because historical data are not available, a great deal of uncertainty exists regarding the future costs of thin-film and concentrator PV systems which are so dependent on R&D funding and for which much industry data is proprietary.

### Technology Comparison

**Solar Resource:** One significant difference between concentrating and other PV systems pertains to the solar resource used. Concentrating PV systems use sunlight which is incident perpendicular to the active materials (direct normal insolation). Other PV systems utilize both direct and indirect (diffuse) solar radiation. Provided in Figure 2, below, are two maps; the first is a map of direct normal insolation, the second is a map depicting global insolation for the U.S.

## OVERVIEW OF PHOTOVOLTAIC TECHNOLOGIES

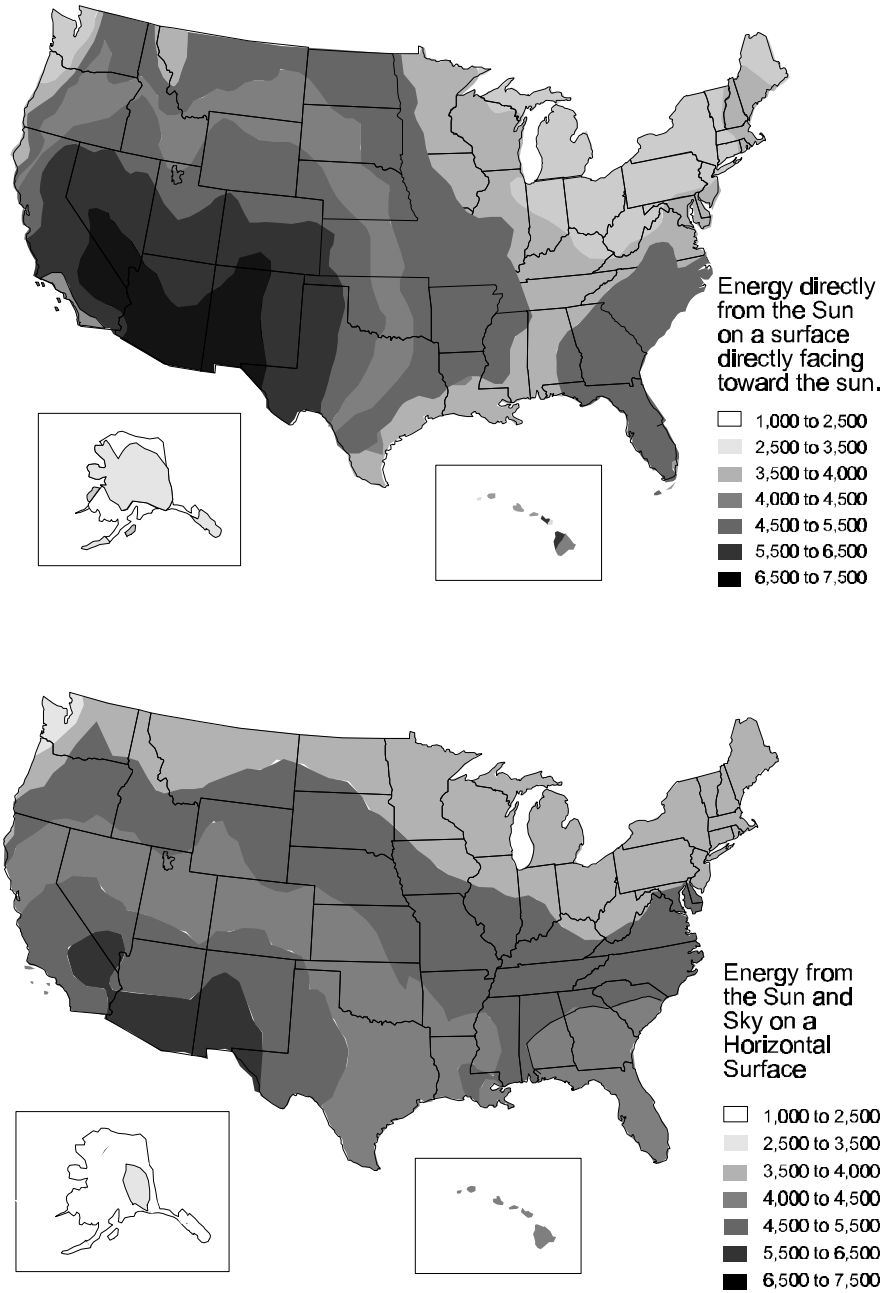

Reproduced from data provided by  
NREL Renewable Energy Resource Information & Analysis Center  
in support of the  
DOE Resource Assessment Program  
Solar Radiation Resource Assessment Project

Figure 2. Direct normal insolation resource for concentrator PV (above) and global insolation resource for crystalline-silicon and thin film PV systems (below).

## OVERVIEW OF PHOTOVOLTAIC TECHNOLOGIES

The main consequence of this difference is that concentrator systems should be deployed in regions that are predominantly cloud free. While other PV systems do not have this requirement, total solar resource quality does of course influence system performance. The PV Technology Characterizations take resource quality into consideration by providing performance estimates based on average and high solar resource assumptions.

Deployment: The deployment needs of the two utility scale applications described in this report are similar. Medium and large-scale deployments have significant land requirements. However, it is important to note that concentrator systems are less appropriate for very small-scale deployments (less than a few tens of kilowatts) due to their costs and complexity. Customer (building) sited PV have no land requirements, however several structural requirements are important (i.e. roof integrity and orientation, shading, pitch, etc.).

Application: The PV systems characterized here all provide distributed benefits. Residential PV systems either feed power into the grid and/or reduce customer demand for grid power. Medium and larger scale systems add capacity incrementally, and to the extent that they match load patterns, may reduce the need for major capital investments in central generation.

Modularity: PV generating systems are easily scaled to meet demand. PV systems can be constructed using one or more modules, producing from a few tens of watts to megawatts. For example, the residential PV systems characterized in this report are a few kW in size, while the concentrating and utility scale thin film PV systems are multi-megawatt applications.

Low-cost operation and maintenance: PV systems have few moving parts. Flat-plate types without tracking have no moving parts, and even two-axis tracking requires only a relatively small number of low-speed moving parts. This tends to keep operation and maintenance costs down. Indeed, some early kilowatt-scale first-of-a-kind plants demonstrated O&M costs around \$0.005/kWh.

### Summary

The PV applications described here are both competitive and mutually supportive at the same time. They are competitive because successful pursuit of one application will divert enthusiasm and resources from the others to some degree; but supportive, because technology and marketing advances fueled by any one of them will also somewhat aid the rest. They do compete to some extent for common markets, but they each serve sufficiently distinct needs to expect their respective niches to persist indefinitely, despite the likelihood that a single one of them may dominate the overall market.

# RESIDENTIAL PHOTOVOLTAICS

## 1.0 System Description

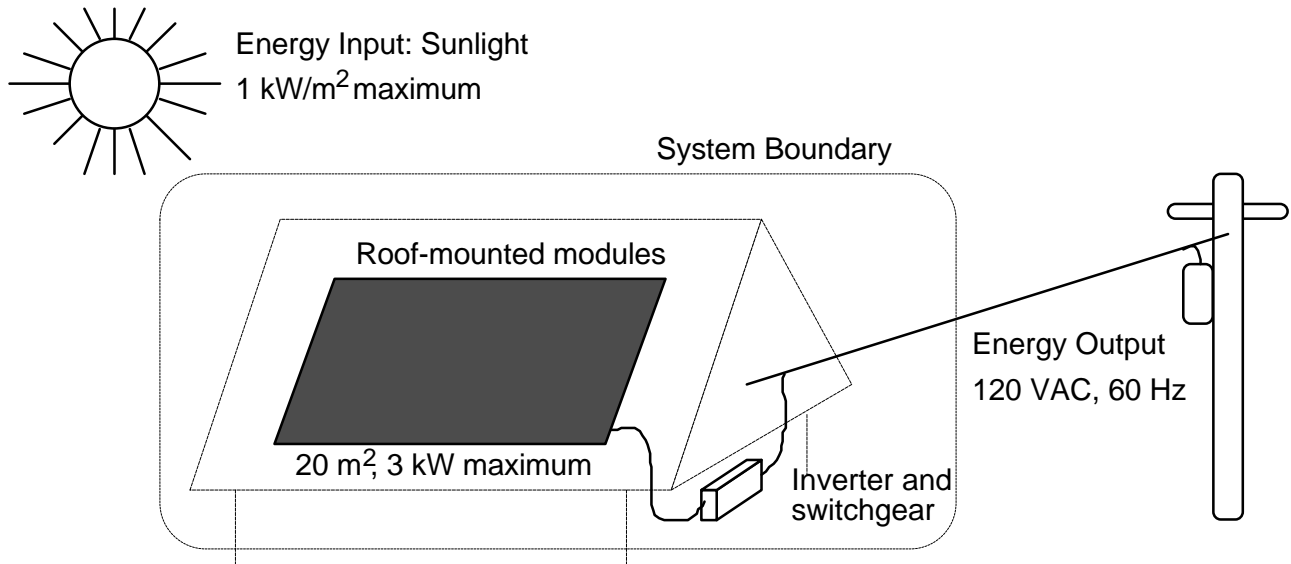

Figure 1. Residential photovoltaic energy system schematic.

Photovoltaic (PV) modules are large-area solid-state semiconductor devices that convert solar energy directly into electrical energy. Individual PV modules produce direct-current (dc) electricity, and are available in sizes from 10 W to 300 W. The actual power output depends upon the intensity ( $\text{W}/\text{m}^2$ ) of sunlight, the operating temperature of the module, and other factors. PV modules are designed and sized to produce the desired electrical output. Addition of electrical power conditioning components (electrical switches, diode protection circuits, dc-to-ac inverters, etc.) are required to interface the PV output with the electrical load. The resulting assembly of components is known as the photovoltaic system.

A residential PV system was selected for this Technology Characterization because it is a well-defined application of the technology, it can have a significant impact on energy use within the United States, and it is an application that effectively utilizes the attributes of PV systems for maximum economical benefit. Customer-sited, grid-tied PV systems are expected to be an early large-scale market for PV energy systems, because these systems take maximum economical advantage of PV technology's positive attributes. Customer siting means that the PV system is located at, or very near, the point of use, and includes applications like residential roof-top PV systems, commercial-building roof PV systems, and building-integrated PV systems. This report examines residential PV systems, but many of the comments pertain to other types of customer-sited PV systems as well.

The residential rooftop PV system (Figure 1) considered in this report has no energy storage. Some (or most) of the energy may be used on site, and a power purchase agreement allows the remaining electricity produced to be fed into the existing utility grid. These PV systems are generally between 1 and 5 kW, and the nominal system considered in this report is 3 kW. (In reality, for this characterization, the system size is held constant at 20 m<sup>2</sup> and the dc rating increases over time to 4 kW). The PV modules are mounted on the roof or, in the future, may be specifically designed as roofing elements (e.g., PV shingles, etc.). The modules characterized here use crystalline-silicon solar cells. In the future, by about 2020, advanced PV technologies – crystalline-silicon ribbon or sheet, and various thin-film (amorphous

## RESIDENTIAL PHOTOVOLTAICS

silicon, cadmium telluride, or copper indium diselenide) materials may be used. While no energy storage is included in the system presented here, energy storage may become economical in the future. The PV modules described here are wired to a single dc-to-ac inverter or, in the future, may include their own individual dc-to-ac inverter. The ac power is tied to the grid through protective switches which disconnect the PV system should the utility power be disrupted. The system costs described here do not include the roof or the building, which are assumed to already exist.

Two sets of systems are described here - that for a single homeowner, who finances and owns the system - and the neighborhood bulk system by a utility or other generating company which installs PV systems on the roofs of many clustered customers. For the latter, the utility finances and owns the systems and achieves certain economies of scale in capital cost, installation, and operations and maintenance (O&M).

### 2.0 System Application, Benefits, and Impacts

Photovoltaic energy systems are currently used wherever relatively small electrical loads (typically less than 100 kWh/month) cannot be conveniently powered by an existing utility grid. As prices for PV technology decline through technology improvements and increased manufacturing automation, PV energy systems will become a viable option for an increasing diversity of loads requiring more power than the typical off-grid small systems used today. The unique advantages of photovoltaics – modularity, good match to many diurnal load patterns, low O&M, environmentally benign, renewable energy source – are expected to be important factors in early cost-effective applications of PV energy systems.

In order for PV to make a significant contribution in the U.S., PV generation will have to interconnect with the electrical grid and compete with existing electrical-energy generation sources. The cost of meeting utility demand is not constant but varies according to the level of load. Times of peak load are associated with the highest cost electricity. This high cost is due to using generation sources with high fixed costs and low efficiency (but often with low or depreciated capital costs), losses due to increased loading of the transmission and distribution (T&D) system during peak periods, and increased size of the T&D system to handle peak loads. The net result is that the full cost for delivering electricity to a customer during summer peaks can be as high as \$0.40/kWh [1,2]. Although PV only generates electricity when the resource is available, this generation tends to correlate reasonably well with daily demand patterns, thereby delivering its output during times of highest value. In order to reduce peak loads, some utilities have employed time-of-day pricing, a strategy which provides incentives to users to implement energy conservation measures and adopt on-site generation sources that reduce peak loads to the central utility. PV energy is well suited to compete with other peak power sources because the PV energy profile roughly matches the electrical load profile in many regions of the country.

Besides meeting peak power requirements, PV is modular, i.e., size and location can be optimized to meet residential and utility requirements. Some of the potential advantages of PV include:

1. PV can capture benefits of distributed electrical energy generation where utility costs associated with transmission and distribution are reduced by locating the electrical generation source close to the point of use [1,2,3,4].
2. Customer-sited PV systems help minimize balance-of-system costs because there are minimal costs associated with site acquisition and preparation and there is generally a pre-existing utility connection to the site [5,6,7].
3. Customer-sited PV fits into the more flexible deregulated utility environment where the generation is no longer necessarily owned by the utility. For example, the residential PV system could be owned by the utility, by an independent power producer who “rents” the rooftop from the residential owner, or by the resident.

## RESIDENTIAL PHOTOVOLTAICS

In addition, PV uses a renewable energy source (sunlight) and produces no emissions during operation. Surveys indicate that many customers are willing to pay a premium for a “green” product (in this case, electricity) that has environmental benefits when compared to competitive products [8].

Because of the benefits described above, residential PV systems are expected to be one of the first grid-tied applications of PV to reach cost effectiveness with existing electrical-energy sources. Residential PV systems also represent a potentially large market. There are approximately ten million single-family homes located in regions of the United States that have above-average sunshine and suitably tilted roofs with unshaded access to direct sunlight. This market has a potential of over 30 GW [9]. For single homeowners to fully realize the potential of residential roof PV energy systems, it would be necessary for the power purchase agreement between the utility and the system owner to reflect some of the economical values described above. Utilities that own neighborhood bulk systems include New England Electric Systems (NEES) in Gardner, MA [10] and the Sacramento Municipal Utility District (SMUD) [11].

PV solar energy provides a number of other benefits besides the value of the energy. Some of these benefits include the following: no fuel or water consumption; low maintenance; improved national energy security; economically important U.S. export technology; and avoidance of CO<sub>2</sub> generation. See a companion report on Utility-Scale, Flat-Plate, Thin-Film Photovoltaic Systems for a more complete discussion on some of these ancillary benefits [12]. Because of the advantages cited above and concerns associated with global climate change, the U.S. Department of Energy announced an initiative to promote the installation of one-million roof top systems (solar thermal and PV), by the year 2010 [13]. The Million Solar Roofs Initiative is a recognition of the readiness of residential and commercial roof solar energy systems to become a significant energy source for the U.S. The technology and regulatory improvements developed under this initiative will help facilitate the more rapid introduction of residential photovoltaic energy systems in the U.S., as costs are driven down. Cost and other technology assumptions and issues are discussed below.

### 3.0 Technology Assumptions and Issues

Residential PV systems are not yet cost competitive with grid-connected electricity; and most of the systems installed to date were subsidized. Many were installed in Japan and in Europe, where there is significant public support of clean energy sources. The bulk of PV modules sold today, and of residential PV systems installed to date, use one-sun modules with crystalline-silicon solar cells. Also, most PV systems are used today in applications where there is no low-cost source of grid electricity.

The technology progress described in this report assumes an orderly expansion and development of the market for residential PV systems, and continued improvement in both cost and performance of the PV modules and balance-of-system components. As the market for these systems increases, installation costs and standardization, along with improved manufacturing processes and increased conversion efficiency, are expected to reduce various cost components significantly. Achievement of the market expansion and technology improvements, however, are not certain and will require significant further public and private investment. Identification of early cost-effective markets and marketing of “green” power will be critical for market expansion in the early years when PV system costs are still much higher than grid-tied electricity. This stage can be assisted through publicly and privately financed programs, including the Million Roofs Solar Initiative, to help identify and develop the interim high-value markets described in Section 2.

Further technology improvements to reduce the cost and improve the performance of PV modules and balance-of-system (BOS) components are required. Substantial reductions in costs and improvements in efficiency have been achieved over the past 20 years. This progress has been greatly assisted by publicly funded R&D. Continuation of this R&D will be instrumental for further progress since the profit margins in the PV industry have been insufficient



## RESIDENTIAL PHOTOVOLTAICS

to support an adequate private R&D program. The recent progress in crystalline-silicon PV technology has been greatly assisted by publicly funded R&D programs like the DOE PV Manufacturing Technology (PVMaT) program and publicly-funded, DOE laboratory and university R&D. Some of the technology improvements and product design changes that have helped reduce cost include the following: casting of larger ingots to improve the productivity of crystal-growth; replacement of inner-diameter saws with wire saws to improve the productivity of slicing ingots; improvement of the yield and throughput of cell fabrication processes, e.g., diffusion and antireflection coating; use of larger area cells to reduce the cost of operations that scale per piece, e.g., screen print and cell tab; and use of larger area modules to reduce the costs of components that scale per module, e.g., interconnection box and module testing. Compared to the present crystalline-silicon PV modules, thin-film PV technology promises further cost reductions because of its inherently lower material and energy content, and to a product design that could be more manufacturable, planar processing of large-area substrates. DOE and private (e.g., EPRI) R&D programs were instrumental in the development of this completely new technology, and the first large-scale, >5 MW/year, thin-film PV plants started operations in 1997. Finally, BOS components are a significant cost factor in PV systems. PV modules with integrated inverters or with building-integrated features may have a significant impact on grid-tied PV system costs.

### 4.0 Performance and Cost

Two sets of performance and cost indicators for the residential PV system being characterized in this report are presented. Table 1 shows figures for a single homeowner, who finances, owns and operates a roof-top system.

Table 2 shows figures for a compact neighborhood grouping of residential systems, where a utility or private developer owns, finances, and provides maintenance. Table 2 illustrates the influence that economies of scale have on system costs. Cost Of Energy figures should be prepared from Table 2, because while the homeowners realize an energy savings, they do not sell power to themselves or take depreciation or tax credits unless they are self-employed.

### 4.1 Evolution Overview

The PV module efficiency and cost projections reflect the expected evolutionary development of crystalline-silicon PV modules. The physics of high-efficiency crystalline-silicon laboratory solar cells is now very well understood, and the best laboratory cell performance today, 24%, is nearing best theoretical expectations, around 30% [14,15]. Hence, the best laboratory cell performance is expected to increase between 25% and 28% by 2030. The efficiency of commercial crystalline-silicon PV modules under standard rating conditions is, therefore, assumed to grow slowly to 20%, which corresponds to about 80% of the performance for the expected best laboratory cell performance of 25%.

Table 1. Performance and cost indicators (C-Si residential PV systems -- individual/single-home basis\*).

INDICATOR NAME	UNITS	Base Case 1997		2000		2005		2010		2020		2030	
			+/- %		+/- %		+/- %		+/- %		+/- %		+/- %
Unit Size	kW <sub>ac</sub>	2.3		2.6		2.8		3.0		3.2		3.4	
Unit Size	kWp <sub>dc</sub>	2.8		3.2		3.4		3.6		3.8		4.0	
Unit Size (module area)	m <sup>2</sup>	20		20		20		20		20		20	
PV Module Performance Parameters													
PV Module (dc) efficiency	%	14		16	10	17	15	18	20	19	20	20	25
Inverter Efficiency	%	90		91	10	92	15	93	20	94	20	95	25
ac System Efficiency	%	11.3		13.1	10	14.1	15	15.1	20	16.1	20	17.1	25
Annual System Performance in Average-Insolation Location (global sunlight, in plane, 1800 kWh/m <sup>2</sup> -yr)													
ac Capacity Factor	%	20.5		20.5		20.5		20.5		20.5		20.5	
Energy/Area	kWh/m <sup>2</sup> -yr	204		236		253		271		289		308	
Energy Produced	kWh/yr	4,082		4,717		5,067		5,424		5,787		6,156	
Annual System Performance in High-Insolation Location (global sunlight, in plane, 2300 kWh/m <sup>2</sup> -yr)													
ac Capacity Factor	%	26.3		26.3		26.3		26.3		26.3		26.3	
Energy/Area	kWh/m <sup>2</sup> -yr	261		301		324		347		370		393	
Energy Produced	kWh/yr	5,216		6,028		6,475		6,930		7,394		7,866	
Capital Cost (1997\$)													
dc Unit Costs													
PV Module Cost	\$/Wp	3.75		3.04	30	2.34	30	1.80	30	1.07	30	0.63	30
Power-Related BOS	\$/Wp	1.50		1.22	30	0.94	30	0.72	30	0.43	30	0.25	30
Area-Related BOS	\$/m <sup>2</sup>	170		138	30	106	30	82	30	48	30	29	30
Area-Related BOS	\$/Wp	1.21		0.86	30	0.62	30	0.45	30	0.25	30	0.14	30
Total BOS	\$/Wp	2.71		2.08	30	1.56	30	1.17	30	0.68	30	0.40	30
System Total	\$/Wp	6.46		5.12	30	3.90	30	2.98	30	1.75	30	1.03	30
System Total	\$	18,100		16,400	30	13,300	30	10,700	30	6,600	30	4,100	30
ac Unit Costs	\$/Wp	7.86		6.30	30	4.74	30	3.58	30	2.08	30	1.21	30
System Operations and Maintenance Cost													
Maintenance (annual)	\$/m <sup>2</sup> -yr	2.0		2.0	30	2.0	50	2.0	50	2.0	50	2.0	50
Total Annual Costs	\$/yr	40		40	30	40	50	40	50	40	50	40	50

Notes:

1. Area-related BOS costs restated to their "power-related" equivalent.
2. The columns for "+/-%" refer to the uncertainty associated with a given estimate.
3. Residential system installation (i.e. "construction") requires several hours or days.

<sup>b</sup> This table reflects an "individual system" scenario, while Table 2 displays further cost reductions possible through volume purchasing.

Table 2. Performance and cost indicators (C-Si residential PV systems -- network neighborhood)

INDICATOR NAME	UNITS	Base Case		2000		2005		2010		2020		2030	
		1997	+/- %		+/- %		+/- %		+/- %		+/- %		+/- %
Unit Size	kW ac	2.3		2.6		2.8		3.0		3.2		3.4	
Unit Size	kWp dc	2.8		3.2		3.4		3.6		3.8		4.0	
Unit Size (module area)	m <sup>2</sup>	20		20		20		20		20		20	
Number of Houses	--	130		385		357		333		313		294	
Plant Size	kW ac	299		1,001		1,000		999		1,002		1,000	
PV Module Performance Parameters													
PV Module (dc)	%	14		16	10	17	15	18	20	19	20	20	25
Inverter Efficiency	%	90		91	10	92	15	93	20	94	20	95	25
ac System Efficiency	%	11.3		13.1	10	14.1	15	15.1	20	16.1	20	17.1	25
Annual System Performance in Average-Insolation Location (global sunlight, in plane, 1800 kWh/m2-yr)													
ac Capacity Factor	%	20.5		20.5		20.5		20.5		20.5		20.5	
Energy/Area	kWh/m2-yr	204		236		253		271		289		308	
Energy Produced/Unit	kWh/yr	4,082		4,717		5,067		5,424		5,787		6,156	
Annual System Performance in High-Insolation Location (global sunlight, in plane, 2300 kWh/m2-yr)													
ac Capacity Factor	%	26.3		26.3		26.3		26.3		26.3		26.3	
Energy/Area	kWh/m2-yr	261		301		324		347		370		393	
Energy Produced/Unit	kWh/yr	5,216		6,028		6,475		6,930		7,394		7,866	
Capital Cost (1997\$)													
dc Unit Costs													
PV Module Cost	\$/Wp	3.15		2.55	30	1.97	30	1.51	30	0.90	30	0.53	30
Power-Related BOS	\$/Wp	1.30		1.05	30	0.81	30	0.62	30	0.37	30	0.22	30
Area-Related BOS	\$/m2	150		122	30	94	30	72	30	43	30	25	30
Area-Related BOS	\$/Wp	1.07		0.76	30	0.55	30	0.40	30	0.22	30	0.13	30
Total BOS	\$/Wp	2.37		1.81	30	1.36	30	1.03	30	0.59	30	0.35	30
System Total	\$/Wp	5.52		4.37	30	3.33	30	2.54	30	1.49	30	0.88	30
System Total	\$	15,500		14,000	30	11,300	30	9,100	30	5,700	30	3,500	30
ac Unit Costs	\$/Wp	6.72		5.34	30	4.04	30	3.05	30	1.77	30	1.04	30
System Operations and Maintenance Cost													
Maintenance (annual)	\$/m <sup>2</sup> -yr	2.0		2.0	30	2.0	50	2.0	50	2.0	50	2.0	50
Unit Annual Costs	\$/yr	40		40	30	40	50	40	50	40	50	40	50

Notes:

1. The columns for "+/-%" refer to the uncertainty associated with a given estimate.
2. Complete system installation (i.e. "construction") on all houses is assumed to require six months.

## RESIDENTIAL PHOTOVOLTAICS

Future years, beginning about 2020, may also see the introduction of building-integrated PV elements (e.g., PV shingles, etc.) that have much improved aesthetics and may further reduce net system costs by replacing other roofing materials [7, 11]. Future years might also see the introduction of thin-film PV technologies [12]. The building-integrated PV and thin-film PV technologies have lower performance compared to crystalline-silicon PV modules at present. The module efficiency is a very important issue for commercial and residential roof PV systems because the available space is fixed. Despite possible improvements in areal (\$/m<sup>2</sup>) or power (\$/W) costs of these advanced PV technologies, their introduction into residential and commercial roof PV systems will probably require performance levels comparable to crystalline-silicon PV. The expected evolutionary development of thin-film PV modules is reviewed in a companion report [12]. The more favorable cost reductions projected for thin-film PV technology would reduce projected system costs in Tables 1 and 2 using crystalline-silicon PV technology projections proportionately.

### 4.2 Performance and Cost Discussion

As indicated in Tables 1 and 2, the physical size of an individual residential PV system is assumed to remain fixed at 20 m<sup>2</sup>, fitting within the unobstructed space available on the south-facing slope of a typical residential rooftop. DC unit ratings increase from 2.8 kW in 1997 to 3.2 kW in 2000 to 4.0 kW in 2030. The rated dc module efficiency and rated dc power are for standard reporting conditions (1 kW/m<sup>2</sup>, 25°C/77°F). The rated ac power is the product of the dc module rating and the inverter efficiency. The system operating efficiency is the product of the module efficiency, the inverter efficiency, and an additional factor of 0.9 to account for operation away from standard rating conditions [16].

The PV output at any given time is directly proportional to the available solar energy (insolation). The cost of producing PV solar energy is therefore inversely proportional to the solar insolation. The solar insolation depends upon latitude, local climate, and PV module mounting. PV module mounting refers to positioning of the PV module with respect to the position of the sun – a tracking PV array collects the maximum available sunlight by pointing the array at the sun as the sun changes position in the sky, while, with a fixed array, the solar intensity changes continuously during the day. Residential systems generally use fixed arrays. Insolation varies between 1.6 and 2.4 MWh/m<sup>2</sup>-yr for a south-facing, fixed array. This report considers both average-insolation (1.8 MWh/m<sup>2</sup>-yr) and high-insolation (2.3 MWh/m<sup>2</sup>-yr) locations. The high insolation location is of particular interest for early cost-effective applications. The annual energy production is the product of the system efficiency and the solar insolation. The ac capacity factor is defined as the annual energy production divided by the product of the rated ac power and the number of hours in a year (8,760).

For Table 1, the PV module, power-related BOS, and area-related BOS costs for the base year were based on the first few large utility-sponsored residential PV system projects (SMUD's PV Pioneers), where houses were widely dispersed. These costs were compared to costs independently estimated using standard construction-industry project estimation procedures [17]. The independent estimate considered both low-voltage and high-voltage dc systems, and considered ac PV modules (PV modules with integrated inverters). At present, low-voltage inverters cost less per rated capacity than high voltage inverters since similar inverters are already manufactured commercially at low volumes for other applications (uninterruptible power supplies). However, low-voltage systems have higher area-related BOS costs due to increased wiring requirements. The ac PV modules have the lowest area-related BOS cost since there is no longer a separate dc system, but the inverters for ac PV modules presently have a higher cost. A large manufacturing volume and some technology improvements (e.g., integrated circuits for power supplies) will be required to reduce the cost of inverters for ac PV modules. Despite these differences, the net result is that the three types of systems had similar total BOS costs. The independent estimate yielded costs similar to the large utility-sponsored project. Most of the systems installed to date use a low-voltage system, which was considered in this report. It should also be noted that the power-

## RESIDENTIAL PHOTOVOLTAICS

related BOS costs include the utility costs for the interconnection, such as replacing a home's meter and adding the disconnect switches to allow for net metering.

For Table 2, a compact neighborhood of houses with rooftop PV systems is assumed. Beginning in 1985, NEE S installed 60 kW of PV on existing residential rooftops in Gardner, MA, plus 40 kW in commercial applications in three nearby states [10]. NEES did not sell the PV systems when it divested its generating assets [18]. A larger series of projects was undertaken by SMUD with their "Residential PV Pioneer" projects, which ranged from 87 kW on 25 homes to 400 kW on 119 homes [11]. In Table 2, for 1997, plant size is assumed to be 0.299 MW based on placing 2.3 kW<sub>ac</sub> systems on 130 homes. For 2000 and later, plant size is estimated at 1.0 MW, assuming systems installed on 385 houses in 2000 to 294 houses in 2030. Experience will lead to an optimal number of homes in the grouping. The compact neighborhood and bulk purchases translate into lower PV module, BOS, and O&M costs relative to similar values in Table 1.

Estimation of costs for highly evolving products like photovoltaic modules and systems over several decades is a very difficult task. One method is to extrapolate from historical data. A useful tool for performing extrapolations of the costs of manufactured products from historical data is the learning curve [19-21]. This method is derived from examination of cost data for many different industries, which has found that the cost of the product in constant dollars is a geometric function of the product's cumulative volume. The price reduction expected for a doubling of volume is known as the learning curve factor. The learning curve may be combined with an annual projected growth rate to estimate the annual reduction in product cost.

Data for the price of PV modules, as a function of cumulative volume, has been analyzed by several groups, and the reported learning curve factors between 0.68 and 0.82 [19-21]. The more conservative learning curve factor of 0.82 was used in this study because analyses of many other industries have found similar values [21]. This value means that a doubling of the cumulative volume of PV modules sales will reduce the cost of PV modules to 82% of its previous value. The annual growth rate in PV module sales has been between 15-20% in recent years [22,23]. Given the strong demand for PV modules and the broad interest in accelerating adoption of PV energy (e.g., Million Solar Roof Initiative), an annual growth rate of 20% can be conservatively assumed. A learning curve factor of 82% and assumed growth rate of 20% yield an estimated price reduction of 5% per year. An annual growth rate of 20% and annual cost reduction of 5% is used to generate the projections for the years 2000-2030 (Table 3). The price of \$3.15 in 1997 is based on the estimated module price of one of the lowest recent bid system prices (\$5.76/W<sub>p</sub> for SMUD PV Pioneer residential PV systems). The average wholesale price of crystalline-silicon PV modules has stayed around \$4.00/W<sub>p</sub> in recent years because of increased demand and constrained capacity. Table 3 illustrates the potential of the technology, given a more mature market.

Table 3. Projections of crystalline-silicon photovoltaic module sales and prices.

Year	Module Effic. (%)	Annual Sales (MW)	Price (\$/W <sub>p</sub> )	Sales (\$M)	Module (\$/m <sup>2</sup> )
1997	14	84	3.15	265	441
2000	16	174	2.55	444	408
2005	17	433	1.97	853	335
2010	18	1,078	1.51	1,628	272
2020	19	6,678	0.90	6,010	171
2030	20	41,347	0.53	21,914	105

The prices in Tables 1, 2, and 3 are all in constant 1997 dollars, excluding inflation. Therefore, if the average inflation rate also happened to equal our average annual cost reduction of 5%, the price of PV modules in 2030 would be \$3.15

## RESIDENTIAL PHOTOVOLTAICS

in current-year dollars. Also note that *Price* does *not* refer to the manufacturing cost and as such reflects overhead factors as marketing, distribution, and research and development.

The validity of using the learning curve to extrapolate PV module costs to the low values after year 2010 should be assessed because the nature of the industry might change at the larger sales volumes or other more fundamental (i.e., physical) limits might arise. A second type of cost extrapolation was used to check the validity of the preceding table. This cost estimate used a “bottom up” analysis of the industry; i.e., the manufacturing cost is estimated at different production volumes for a specific proposed factory and manufacturing process. A detailed study was recently completed by a European research group [24]. The study estimated the manufacturing cost of crystalline-silicon and thin-film PV modules at a production level of 500 MW per year. The European study estimated a *manufacturing cost* of \$1.30/W for both the crystalline-silicon and thin-film PV at a production level of 500 MW per year. The manufacturing cost of \$1.30/W compares well with our learning curve-based, extrapolated *price* of \$1.92/W at a production level of 433 MW per year. This comparison gives confidence in using the learning curve to extrapolate PV module costs.

There is less data available for BOS components to estimate learning curve factors. Substantial cost reductions are still possible in the small inverters used for residential systems through design changes (reduce high-cost ferromagnetic materials with silicon devices), technology improvements (e.g., integrated circuits for power supplies), and high-volume manufacturing [25]. Improvement in system design and standardization of components will reduce area-related BOS (i.e., installation and wiring) costs, and a substantial impact would be expected with the successful development of an ac PV module. Some observers suggest that there is little learning improvement available in BOS due to the maturity of the industry; for example, the costs of installation and wiring are well known from the much larger construction industry [26]. Nevertheless, a recent project achieved a 50% reduction in BOS costs for ground-mounted PV systems through improvements in integration of the system components [27]. As was the case for modules, a learning curve factor of 0.82 and a growth rate of 20% were used, and these correspond to an estimated cost reduction per annum of 5%, for both power- and area-related BOS. The uncertainties in BOS costs in later years are larger because of the difficulty in projecting the performance of a maturing industry with multiple technology options.

As pointed out earlier, PV systems have very low operation and maintenance costs. A recent study examined the performance of a residential PV energy system after ten (10) years of operation [28]. This study found that the system, with the exception of some of the power conditioner components, was highly reliable and had minimal O&M costs. The report found an average annual O&M cost of only \$52. The O&M cost represents a maintenance contract in Table 1 when the system is owned by the homeowner. In Table 2, it represents the cost of system monitoring and maintenance if the system is owned by the utility or a third party. The components and system are anticipated to have 20-year warranties, so no cost for component replacement was included.

### 5.0 Land, Water, and Critical Materials Requirements

No land or water resources are required for operation of the system (Table 4), which is installed on existing structures and uses rainwater for cleaning. The only critical material for crystalline-silicon PV modules is high-purity silicon. Silicon is one of the most abundant elements in the earth’s crust, so the issue is not availability but the cost of purification. High-purity silicon is typically produced as either pellets or chunks of fine-grained polycrystalline silicon and is commonly known as “polysilicon feedstock.”

## RESIDENTIAL PHOTOVOLTAICS

Table 4. Resource requirements.

Indicator Name	Units	Base Year					
		1997	2000	2005	2010	2020	2030
Land	ha/MW	0	0	0	0	0	0
	ha	0	0	0	0	0	0
High Purity Silicon	MT/MW	6.9	5	4	3	2	1
Water	m <sup>3</sup>	0	0	0	0	0	0

The availability of polysilicon feedstock is currently an issue for the crystalline-silicon photovoltaic industry, so its availability to meet future large markets needs to be addressed [29,30]. The crystalline-silicon photovoltaic industry used approximately 1,000 MT of polysilicon feedstock in 1995. It obtains most of this material as off-specification material from the electronic-grade polysilicon feedstock industry. The quantity of silicon consumed by the photovoltaic industry is about 10% of the total electronic-grade polysilicon feedstock production. The price and availability of this material is affected by the business cycle of the semiconductor electronics industry. For example, there was excess capacity in the electronic-grade polysilicon feedstock industry between the years 1985 and 1993 – so that the excess feedstock from the electronic-grade silicon industry was both plentiful and inexpensive. Due to the phenomenal growth rate of the semiconductor electronics industry over the past three years, demand for electronic-grade silicon now exceeds supply – which has led to the present situation of a tight polysilicon feedstock supply for the photovoltaic industry. Again illustrating the business-cycle nature of the polysilicon feedstock supply, one industry observer notes that announced capacity additions in the electronic-grade polysilicon industry, coupled with the more stringent specifications for advanced integrated-circuit production, are likely to lead to a doubling of the quantity of excess silicon available to the photovoltaic industry within the next five years [30]. The average growth rate of electronic-grade polysilicon feedstock between 1975 and 1995 was around 10%, while the average growth rate of the photovoltaic industry is projected to be around 20%. Hence, the photovoltaic industry will become too large to use excess polysilicon feedstock from the electronic-grade polysilicon feedstock industry at some point in the future using current technology.

To meet large future markets, the crystalline-silicon photovoltaics industry will need to develop its own source of polysilicon feedstock. The European study projected that using current technology, a photovoltaic-grade polysilicon feedstock could be produced for about \$20/kg [24]. There are R&D programs that are attempting to develop technologies to reduce this cost further [31]. Present wire-saw technology can slice silicon wafers on 400- $\mu$ m centers, which corresponds to about 7 g/W for 15%-efficient cells with 90% manufacturing yield. At \$20/kg, the 7 g/W corresponds to \$0.14/W. This figure will not limit the industry through the year 2010. By the year 2010, new crystalline-silicon photovoltaic technologies that use much less silicon per watt are anticipated to become widely available. For example, ribbon and sheet crystalline-silicon technologies, which can have effective silicon thicknesses between 100 and 200  $\mu$ m, are just becoming commercially available. The thin-layer crystalline-silicon film cells that are currently under development have thicknesses between 10 and 50  $\mu$ m, and might be available after the year 2010.

Using the previous assumptions of 15%-efficient modules and 90% manufacturing yield, the polysilicon usage and cost for these technologies are summarized in Table 5.

## RESIDENTIAL PHOTOVOLTAICS

Table 5. Projected silicon feedstock usage and cost for various crystalline-silicon photovoltaic technologies.

Technology	Thickness μm	Usage g/W	Cost \$/W <sub>p</sub>	Cost \$/m <sup>2</sup>
Wire Saw	400	6.9	0.138	20.70
Ribbon	200	3.5	0.069	10.35
Sheet	100	1.7	0.035	5.25
Thin-layer	50	0.9	0.017	2.55
Thin-layer	10	0.2	0.003	0.45

Note: Calculations assume a module efficiency of 15%, a manufacturing yield of 90%, and a polysilicon feedstock cost of \$20/kg.

This analysis shows that the cost impact of the polysilicon feedstock is progressively less for the advanced technologies available in the future. Based on the anticipated establishment of a polysilicon feedstock production for photovoltaics at around \$20/kg and the technology improvements available in crystalline-silicon photovoltaics, polysilicon feedstock is not considered a fundamental issue limiting continued crystalline-silicon photovoltaic industry expansion. However, as with any developing business requiring large capital expenditures, there may be periods of difficulty until a dedicated photovoltaic-grade silicon supply is established. Of course, the emergence of thin-film technologies in future years may also obviate polysilicon feedstock limits on PV module production. Critical material issues associated with thin-film PV production are reviewed in a companion report [12].

### 6.0 References

1. Annan, R.H., "Solar 2000: Office of Solar Energy Conversion Strategy," Proceedings of the 22nd IEEE PV Specialist Conf., Las Vegas, NV (1991).
2. Shugar, D.S., "Photovoltaic in the Utility Distribution System: The Evaluation of System and Distributed Benefits," Proceedings of the 21st IEEE PV Specialist Conference, Kissimmee, FL (1990).
3. Iannucci, J.J., and D.S. Shugar, "Structural Evolution of Utility Systems and Its Implications for Photovoltaic Applications," Proceedings of the 23rd IEEE PV Specialist Conference, Louisville, KY (1993).
4. Wegner, H., et al., "Niche Markets for Grid-connected Photovoltaics," Proceedings of the 25th IEEE PV Specialist Conference, Washington, D.C. (1996).
5. Shugar, D.S., M.G. Real, and P. Aschenbrenner, "Comparison of Selected Economics Factors for Large Ground-Mounted Photovoltaic Systems with Roof-Mounted Photovoltaic Systems in Switzerland and the USA," Proceedings of the 11th E.C. Photo. Solar Energy Conf. (1992).
6. Osborn, D.E., and D.E. Collier, "Utility Grid-connected Photovoltaic Distributed Power Systems," Proceedings of the National Solar Energy Conf., ASES Solar 96, Asheville, NC (April 1996).
7. Strong, S.J., "Power Windows: Building-integrated Photovoltaics," IEEE Spectrum, October 1996, pp. 49-55.
8. Lamarre, L., "Utility Customers Go for Green," EPRI Journal, March/April 1997, pp. 6-15.



## RESIDENTIAL PHOTOVOLTAICS

9. The Market for Solar Photovoltaic Technology, Arthur D. Little Inc., for the Electric Power Research Institute: March 1993. Report EPRI/TR-102290.
10. Strong, S.J. with W.G. Scheller, *The Solar Electric House*, Sustainability Press, Still River, MA; 1991.
11. Osborn, D.E., "Commercialization of Utility PV Distributed Power Systems," Proceedings of the 1997 American Solar Energy Society Annual Conference, ASES Solar 97, Washington, D.C. (April 25-30, 1997).
12. "Utility-Scale, Flat-Plate Thin Film Photovoltaic Systems," EPRI/DOE report, to be published concurrently with this report.
13. U.S. Department of Energy, "Peña Outlines Plan to Send Solar Sales Through the Roof," Press Release, June 27, 1997.
14. Zhao, J., et al., "Twenty-four Percent Efficient Silicon Solar Cells with Double Layer Antireflection Coatings and Reduced Resistance Loss," *Applied Physics Letters*, Vol. 66, pp. 3636-3638 (1995).
15. Shockley, W., and H.J. Queisser, "Detailed Balance Limit of Efficiency of p-n Junction Solar Cells," *Journal of Applied Physics*, Vol 32, pp. 510-519 (1961).
16. *The Design of Residential Photovoltaic Systems*, Sandia Photovoltaic Systems Design Assistance center : December 1988. Report SAND87-1951.
17. Crosscup, R.W., ed., *Means Electrical Cost Data, 1996*, Robert Snow Means Co., Kingston, MA, 1996.
18. "USGen's 5,000 MW of NEES Plants is first big Utility Transfer to an IPP," *Independent Power Report*, McGraw Hill, New York, August 22, 1997, pp. 20-21.
19. Cody, G., and T. Tiedje, "A Learning Curve Approach to Projecting Cost and Performance in Thin Film Photovoltaics," Proceedings of the 25th IEEE PV Specialist Conference, Washington, D.C. (1996).
20. Henderson, E.J., and J. P. Kalejs, "The Road to Commercialization in the PV Industry: A Case Study of EFG Technology," Proceedings of the 25th IEEE PV Specialist Conference, Washington, D.C. (1996).
21. Williams, R.H., and G. Terzian, *A benefit/cost analysis of accelerated development of photovoltaic technology*, Center for Energy and Environmental Studies, Princeton University: October 1993. UP/CEES Report 281.
22. Maycock, P.D., ed., "Summary of World PV Module Shipments," *PV News*, Vol. 15, No. 1-2, (January 1996).
23. Gay, C.F., and C. Eberspacher, "Worldwide Photovoltaic Market Growth 1985-2000," *Prog. in Photovoltaics* Vol. 2, pp. 249-255 (1994).
24. Bruton, T.M., et al., "Multi-Megawatt Upscaling of Silicon and Thin-film Solar Cell and Module Manufacturing – MUSIC FM," Proceedings of the Eur. Conf. on Renewable Energy Development, Venice, Italy (November 1995).
25. Bower, W., et al., "Balance-of-System Improvements for Photovoltaic Applications Resulting from the PVMA T Phase 4A1 Program," to be presented at the 26th IEEE Photovoltaic Specialists Conference, Anaheim, CA,

## RESIDENTIAL PHOTOVOLTAICS

(September 19 - October 3, 1997); and Bulawka, A., S. Krauthamer, and R. Das, "U.S. Department of Energy Directions in Photovoltaic Power Conditioner Development Using Smart Power/Power Integrated Circuit Technologies," Proceedings of the 1st World Conf. on PV Energy Conversion, Waikoloa, HI.

26. Duke, R., and D.M. Kammen, "Evaluating Demand-Side Technology Commercialization Measures: Insights from Experience Curves for Fluorescent Lighting and Photovoltaics," submitted to Energy Policy, April 1997.
27. Stern, M., et al., "Development of a Low Cost Integrated 15 kW A.C. Solar Tracking Sub-Array for Grid Connected PV Power Systems Application," ed. C.E. Witt, M. Al-Jassim, and J.M. Gee, Aip Conf. Proceedings 394, 1996, pp. 827-836.
28. Lepley, T., and P. Eckert, "Results from Ten Year's Operation of a 4 kW Grid-connected Residential PV System in Yuma, Arizona," Proceedings of the 223rd IEEE PV Specialist Conference, Louisville, KY (May 1993).
29. Brenneman, B., Silicon Feedstock for Photovoltaics: Supply, Demand, and Availability, Final Report, DynCorp I&ET, Energy Programs Group, Alexandria, VA: April 1996.
30. McCormick, J.R. "Current Status of the Polycrystalline Silicon Industry," Proceedings of the 6<sup>th</sup> Workshop on the Role of Impurities and Defects in Silicon Device Processing, Snowmass, CO (August 1996).
31. Hanazawa, K., et al., "Purification of Metallurgical Grade Silicon by Electron Beam Melting," Proceedings of the 9<sup>th</sup> Intern. Photo. Science and Engineering Conference, Miyazaki, Japan, (November 1996).

# UTILITY-SCALE FLAT-PLATE THIN FILM PHOTOVOLTAICS

## 1.0 System Description

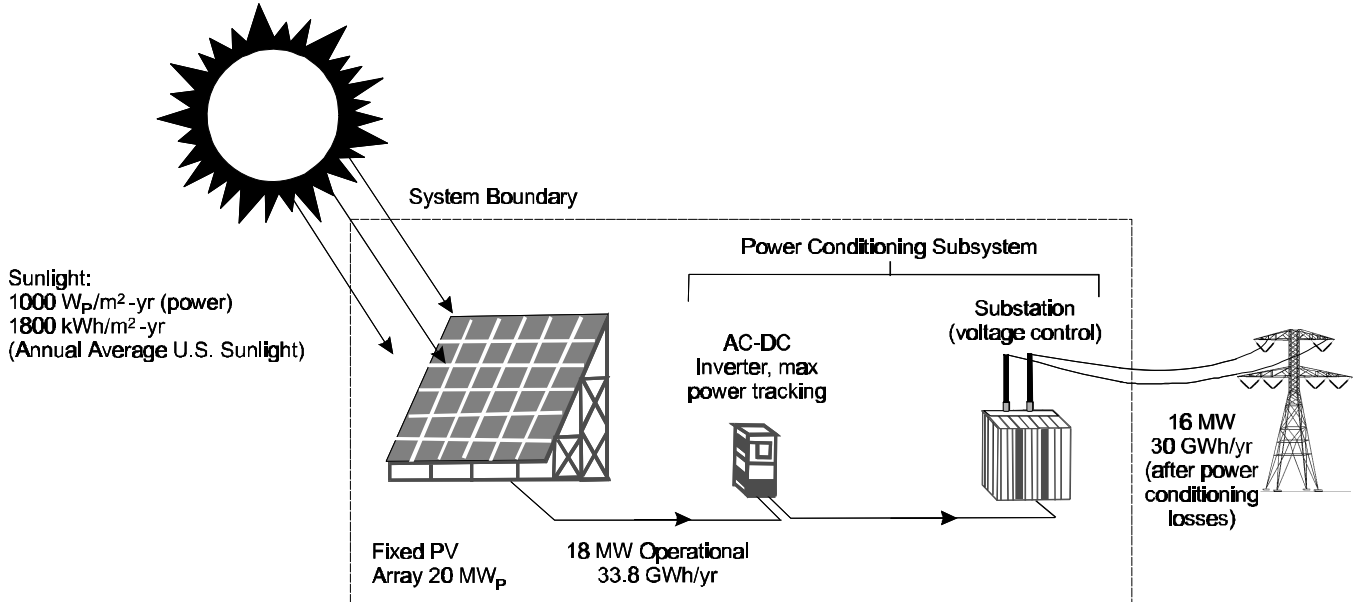

Figure 1. 20 MW<sub>p</sub> (DC)/16 MW<sub>p</sub> (AC) grid-connected PV system schematic.

Thin film photovoltaic (PV) systems convert sunlight into DC electricity using large-area, solid-state semiconductor devices called thin film PV modules. This section characterizes fixed (nontracking), grid-connected systems in the U.S. producing conditioned, AC electricity (Figure 1). The system in this document is a composite based on the three most mature thin films. In addition to thin film modules, PV systems include other components: support structures, inverters if AC electricity is desired, a solar tracker if needed (not in this study), wiring and transmission, and land. Figure 1 shows the losses between each part of the PV energy delivery system: the amount of sunlight and the power and energy produced at the module level (called the system's 'peak power' when the output of all the modules is summed); and the power-conditioning subsystem (including DC-to-AC inverter) with the losses in wiring and DC-to-AC power conversion. The 'peak power' is only the starting point. By the time the electricity gets to the busbar, losses are about 20% of the initial, peak system total. These losses are taken into account in the energy and cost calculations.

The system input is sunlight. The amount of incident sunlight depends on the latitude and local climate. U.S. average annual solar energy input is about 1800 kWh/m<sup>2</sup>-yr for a nontracking array, and varies by about 30% from this amount within the Continental U.S. [1]. For a single-axis tracking array, average output increases to about 2,200 kWh/m<sup>2</sup>-yr and to about 2,400 kWh/m<sup>2</sup>-yr for a dual-axis system [1]. Despite the higher available energy, trackers are not necessarily preferable, since they add cost, have moving parts, and require maintenance. In this characterization, we describe only fixed (nontracking) systems, and we describe *two* levels of sunlight as input to our PV arrays: a high level (2,300 kWh/m<sup>2</sup>-yr) to characterize solar installations in areas of exceptional sunlight; and 1,800 kWh/m<sup>2</sup>-yr as an average case, to indicate a more typical level for the U.S.

The use of an *average U.S. solar location* to calculate cost projections for the long-term allows us to generalize conclusions about the impact of the PV characterized here. The economics of a PV system are inversely proportional to the amount of local sunlight. Since sunlight variation in the U.S. is about 30% from an average value, meeting low-

## UTILITY-SCALE FLAT-PLATE THIN FILM PHOTOVOLTAICS

cost goals in an average location would qualify PV for consideration in almost all U.S. climates and most global locations. For example, if future PV systems were to produce electricity at 6¢/kWh in Kansas (U.S. average sunlight), the same system would produce electricity at 8¢/kWh in New York State and at 4¢/kWh in the Desert Southwest. These extremes could still provide acceptable costs, given the variation of the cost of conventional electricity (although, of course, such cost variations are unrelated to variations in sunlight). It should also be noted that the first large installations of PV are likely to be in areas of high annual sunlight (or locally high electricity prices). We will capture this by using our 'high sunlight' assumptions to describe pioneering installations by 'early adopters'. Longer-term projections are all based on systems located in areas of average sunlight.

### 2.0 System Application, Benefits, and Impacts

PV will be used for many, diverse applications, including utility grid power. The system defined here is for future, grid-connected applications. Since such systems will evolve from today's smaller systems, they have been sized at 20 kW<sub>p</sub>-10 MW<sub>p</sub> in the early years, reaching 20 MW<sub>p</sub> (as a typical size) in 2010. Actual size will depend on individual, grid-connected applications. However, since PV systems are highly modular (i.e., modules and partial arrays can be mass produced in the factory), costs are related predominantly to production volume, not to system size.

Two major markets are expected for the kind of multi-use system described in this characterization. In the U.S., distributed systems delivering electricity at peak demand periods would be the main application [2]. Some intermediate daytime loads would also be met. In developing countries, non-grid-connected systems would provide power to the hundreds of thousands of villages that have no electricity grid. Both of these markets would take advantage of significant values that PV electricity can provide. In the U.S., PV output is well-matched to the needs of many utilities for peak power during the daytime for commercial and air-conditioning loads [2]. This is the most costly electricity for utilities to generate. In addition, PV can be used in distributed locations (i.e., closer to the customer) on a utility grid, reducing the need to add capacity to transmission lines to serve growing suburban communities. Modularity provides relative ease of siting and rapid installation. In the developing nations, there are few alternatives to PV for rural use: diesel generators would be the direct competition. However, diesels require a constant supply of fuel and substantial maintenance, while PV has no need for on-site labor during operation, and has very low maintenance requirements.

PV benefits are numerous. Those described here are in terms of the value of using PV generally, as would result once competitive costs are achieved. PV requires no fuel or water, and is low-maintenance during use. It is an energy source that can be used to 'domesticate' (rather than import) energy, reducing import expenditures. Since sunlight is a local fuel that is available globally, national energy security would be enhanced. In addition, since many PV markets are international, production and export of these high-tech products would benefit the U.S. economy. For developing countries, the value of rural electrification is substantial, since it helps stabilize rural-to-urban population shifts while increasing food supplies, improving food storage, and raising the productivity and living-standard of rural economies. PV use by developing countries would help avoid greater dependence on conventional energy sources and their concomitant emissions.

The solar resource base of the Continental U.S. is over 10<sup>16</sup> kWh/year. U.S. electricity use is about 2.5 x 10<sup>12</sup> kWh/year. Thus, the U.S., an intense user of energy, has about 4,000 times more solar energy than its annual electricity use. This same number is about 10,000 worldwide. Thus PV could in principle provide all the globe's electricity. In particular, if only 1% of land area were used for PV, more than ten times the global energy could be produced (without impacting water and other important resources). The potential of PV to displace major amounts of conventional energy, ultimately depends on the technical viability of cost-competitive PV technologies, storage, and transmission. After cost

## UTILITY-SCALE FLAT-PLATE THIN FILM PHOTOVOLTAICS

reductions are achieved, the biggest barriers to the generalized use of PV beyond an estimated 10% daytime level in developed countries will be the need for electricity storage or advanced transmission schemes that would allow greater dispatchability.

The size of future PV markets will ultimately be determined by the economics of PV systems. Future, lower cost PV systems (such as those based on thin films) have the potential to be used globally on a very large scale. If cost barriers can be overcome, U.S. usage (without storage) of up to 10% of our utility electricity production (more than 200 GW<sub>p</sub> PV capacity based on projected future U.S. electric capacity) is feasible. Use in developing countries could be as large or larger.

The environmental impacts of thin film PV are minimal and in general, PV is emission-free. Some impacts may be expected during system manufacture; and issues exist for polycrystalline thin film systems in terms of ultimate disposal/recycling. These issues are very minor compared to fuel-based energy production and are adequately addressed in References 3-13. (Reference 13 is a bibliography of 94 sources on PV environment, safety, and health issues.) There are some issues specific to compound semiconductors such as those found in polycrystalline thin films. Those are also covered in the same references, where 'cradle-to-cradle' recycling schemes have been outlined for key materials (see also below). For example, U.S. cadmium telluride (CdTe) companies have announced recycling and product 'take-back' strategies [14].

In terms of energy use, a PV-based system would radically reduce total fuel-cycle emissions to approximately 5% of conventional, including full energy payback. Calculations show that thin films require much less energy to manufacture than do other PV alternatives (except perhaps concentrator PV). The amount of CO<sub>2</sub> produced during manufacture of thin films is small (about 5%-10% of the amount avoided, [15]). We expect that the mature production of thin films will result in energy paybacks of under three years for the entire system [15]. Since PV systems are expected to have useful lives exceeding thirty years, this implies that the reduction of CO<sub>2</sub> due to using PV is about 90% to 95% in comparison with conventional sources. Based on 0.3 million metric tons (MMT) of avoided CO<sub>2</sub>/GW of installed PV/yr (assumes 2,000 GWh/GW<sub>p</sub>-yr and 150 MT avoided CO<sub>2</sub>/GWh), a scenario in which 230 GW of PV would be installed by 2030 would avoid 70 MMT of CO<sub>2</sub>/yr (and would have avoided about 800 MMT CO<sub>2</sub> over the entire 1995-2030 timeframe). Since we expect PV to keep expanding in use beyond 2030, these avoided emissions would be only the beginning of a longer term reduction in CO<sub>2</sub>.

### 3.0 Technology Assumptions and Issues

Thin film PV devices are very different from today's common PV devices made from crystalline silicon. Thin films use 1/20 to 1/100 of the material needed for crystalline silicon PV, and appear to be amenable to more automated, less-expensive production. For a review of thin film PV see References 16-32. There are three thin films that have demonstrated good potential for large-scale PV: amorphous silicon (a-Si), copper indium diselenide (CIS), and cadmium telluride (CdTe). Others are at somewhat earlier levels of maturity (film silicon and dye-sensitized cells). The system in this document is a composite based on the three most mature thin films. It is generally believed that all thin films share similar characteristics: the potential for very low module cost (under \$50/m<sup>2</sup> of module area) and reasonable module efficiencies (13%-15% or more), implying potential module costs *well under* \$0.5/W<sub>p</sub>. See References 22-32 and a cost analysis below for an in-depth discussion of thin film module manufacturing costs. Thus, this assessment is a projection of a 'best, future' grid-connected thin-film PV system such as might be used in the U.S. to produce daytime electricity, after the turn of the 21st century.

## UTILITY-SCALE FLAT-PLATE THIN FILM PHOTOVOLTAICS

Thin film PV modules currently in production are based on amorphous silicon. Others, based on polycrystalline thin films, are in pilot production. Substantial commercial interest exists in scaling-up production of thin films. As thin films are produced in larger quantity, and as they achieve expected performance gains, they will become more economical for large-scale electrical utility uses and for large-scale non-utility off-grid uses in developing countries. Even though some thin film modules are now commercially available, their real commercial impact is only expected to be significant during the next three to ten years. Beyond that, their general use should occur in the 2005-2015 time frame, depending on investment levels for technology development and manufacture. The 'best future' grid-connected PV system described here requires that thin films continue to make the high-risk transition from lab-scale success to commercial success throughout this same period. As such, the technical and financial risks remain substantial. These affect the uncertainty of the projections.

Although some thin film modules are commercially available, developmental work is ongoing and remains key to their success. Indeed, to meet the economic goals needed for large-scale use, *much more technical development is needed*. Near term (3 to 10 years) commercial products will not be inexpensive enough to compete with conventional systems for volume U.S. utility-connected applications. Important technology development must be carried out to (1) transfer very high thin film PV cell-level efficiencies (up to 18%) to larger-area modules, (2) optimize processes and manufacturing to achieve high yields, high rates, and excellent materials use, and (3) to assure long-term outdoor reliability. Today's technology base suggests that (with adequate resources) all of these important goals can be achieved [16-32], but each will be challenging.

Funding by the government for technology development has been critical to the thin film technologies described here. Current Federal PV R&D funding is about \$40M annually. Federal funding for *thin films* is about half this total (\$20M/year). Without it, most people believe that thin film PV would not exist in the U.S. Since almost every PV company is presently losing money, they would not be likely to pursue advanced R&D without public investment. The U.S. Federal investment in thin film R&D is more than half of the total U.S. corporate investment in thin films. Continued government funding of thin film technology development is crucial, and were it to dissipate, none of the projections in this characterization would likely be realized. Secondly, worldwide government spending is now expanding in 'markets', and to some extent we assume that this trend will continue. However, we are not assuming that market subsidies will drive the future of PV, as research funding does. (At current system prices of \$5-\$10/W<sub>p</sub> installed, \$10 million per year of Federal spending would only buy 1-2 MW of PV. This kind of spending cannot drive down prices.) Instead, the current State and Federal market support is aimed at facilitating PV market entry, not pulling PV costs down a 'learning curve' at an accelerated rate. Future funding is uncertain, and major changes could occur in either direction: critically enhanced or critically reduced PV budgets for technology development or market development. Either would change our picture about the future, *but reductions in R&D investment would invalidate many of the conclusions of this assessment*.

At some point (as PV costs drop), new forms of financing for U.S. and international markets must be developed for PV to become of global significance. We see hints of this future in the World Bank's Global Environment Facility (to fund CO<sub>2</sub> reductions in developing nations). However, as PV becomes a more relevant participant in global markets, developing new financial tools will be critical. Without some stimulus, U.S. utilities (and those in developed countries) are unlikely to press for large-scale use of PV. This is true in the near term (due to high prices) and may even be true in the longer term, especially if commodity energy prices stay low. This utility inertia may occur because even at lower costs (under 6¢/kWh), PV will remain marginally attractive on a purely avoided energy cost' basis. (This is not to discount large-scale use for peak shaving and other specialty markets.)

# UTILITY-SCALE FLAT-PLATE THIN FILM PHOTOVOLTAICS

## 4.0 Performance and Cost

Table 1 summarizes the performance and cost indicators for the flat-plate, thin film photovoltaic system being characterized in this report.

### 4.1 Evolution Overview

In the initial years (prior to 2005), we expect that the only commercial thin film, amorphous silicon, will compete directly with crystalline silicon (the existing PV market leader). Costs should drop steadily. Cost drops will be driven by increased manufacturing volumes, access to more standardized markets, and improvements in process technology (materials use, rates, yields). During the same period (before 2005), at least one other thin film (most likely CdTe) will enter the marketplace in a significant fashion, further adding to competitive pressures for cost reduction. Because CdTe technology appears to have greater near-term potential for higher efficiency and lower cost than amorphous silicon, cost reduction should accelerate. Thus we see fully loaded module manufacturing costs dropping from today's about  $\$4/W_p$  to about  $\$2.2/W_p$  in 2000 and  $\$1.0/W_p$  in 2005. It should be noted, however, that these cost reductions depend strongly on the timing of (1) increases in production volume, (2) the introduction of the CdTe technology to large-scale manufacturing (over 20 MW), and (3) ongoing market growth. If these do not occur, the attainment of  $\$1/W_p$  will be delayed up to five years. Module costs are likely to fall by another factor of three by 2030 as (1) the efficiency of commercial modules rises from 10% to 15% and (2) direct manufacturing costs drop from about  $\$90/m^2$  to about  $\$45/m^2$ . Details concerning this progress are in the following sections. They are mostly dependent on technical progress such as improvements in device designs, process rates, process yields, and materials utilization rates. The cost and performance projections made in this section depend on continued steady progress in thin film PV. Although good progress has been made in recent times, ongoing progress can not be assured.

### 4.2 Performance and Cost Discussion

The AC, grid-connected systems characterized here range in size from 20 kW to 20 MW. All systems are fixed, flat-plate for simplicity of design and use. Actual systems will vary, without major impact on costs. The systems use the best available thin film in any given year (unknown at this time). See References 17-19, 22-33 for details on projected efficiencies and costs. Since 'capacity factor' depends only on tracking and system loss assumptions, capacity factor is assumed constant (21% for average sunlight, 26% for high sunlight) throughout the period. It may improve slightly during the period covered.

The expected economic life of the system is 30 years, although this is somewhat arbitrary. Solid-state devices such as PV modules may eventually last fifty years or more, although other mechanical and electrical aspects of systems may never be as robust. An ongoing outdoor thin film module test at NREL, and parallel accelerated tests [34], form the basis for reliability projections for thin films (see Figure 2). The system construction period is assumed to be less than one year, based on the fact that many such systems are already being built in similar construction times.

Table 1. Performance and cost indicators.

INDICATOR NAME	UNITS	Base Case		2000		2005		2010		2020		2030	
		1997	+/-%		+/-%		+/-%		+/-%		+/-%		+/-%
Plant Size (DC Rating)	MW <sub>p</sub>	0.02		3		10		20		20		20	
Plant Size (AC Rating)	MW	0.016		2.4		8		16		16		16	
Plant Size (module area)	m <sup>2</sup>	333		33,500		91,000		143,000		125,000		118,500	
PV Module Performance Parameters													
Efficiency													
- Laboratory Cell (best)	%	18		19	5	20	5	21	6	22	7	23	8
- Submodule (best)	%	13		15	5	17	5	18	6	19	7	20	8
- Power Module (best)	%	10		12	6	15	10	17	10	18	10	19	10
- Commercial Module	%	6		9	10	11	15	14	25	16	25	17	25
- Commercial Module Output	W <sub>p</sub> /m <sup>2</sup>	60		90	10	110	15	140	20	160	20	170	25
- System Efficiency	%	4.8		7.2		8.8		11.2		12.8		13.6	
System Performance in Average-Insolation Location (global sunlight, in plane, 1800 kWh/m <sup>2</sup> -yr)													
AC Capacity Factor	%	20.7		20.7	5	20.7	5	20.7	5	20.7	5	20.7	5
Energy/Area	kWh/m <sup>2</sup> -yr	86		130	10	158	15	202	25	230	25	245	25
Energy Produced	GWh/yr	0.029		4.4	15	15	20	29	25	29	25	29	30
System Performance in High-Insolation Location (global sunlight, in plane, 2300 kWh/m <sup>2</sup> -yr)													
AC Capacity Factor	%	26.4		26.4	5	26.4	5	26.4	5	26.4	5	26.4	5
Energy/Area	kWh/m <sup>2</sup> -yr	110		166	10	202	15	258	20	294	20	313	25
Energy Produced	GWh/yr	0.037		5.6	15	18.6	20	37	25	37	25	37	30

Notes:

- For each of the six time frames, estimates of uncertainty (+/- %) are provided.
- Output energy (kWh/m<sup>2</sup>-yr) is reduced by 20% to include operational losses as compared with module and system peak watt (W<sub>p</sub>) DC ratings. Output energy is used to calculate the busbar energy cost. The system's AC Rating already includes this 20% reduction. The 20% reduction from the peak power of the modules is as follows: 8% for module performance at higher operating temperatures (about 50 °C instead of 25 °C); 2% for dust accumulation; 5% for wiring and matching modules in array; 5% for DC-to-AC conversion and power conditioning to utility needs. Note that the operating temperature loss is lower than today's array losses because high-band gap materials such as CdTe and amorphous silicon have inherently lower temperature dependencies than crystalline silicon and have half or less losses due to operating at high temperatures.
- Substantial uncertainties exist in both the magnitude and timing of the projections, since progress in PV depends critically on continued research advances. Long-term projections (2030) are based on reaching cost and performance that look practical, based on today's technologies and understanding. It is likely that actual 2030 achievements will be better than those assumed here because of innovations that are beyond what we can envision today.
- Energy delivery equals AC Capacity Factor, times plant size (AC Rating), times 8,760 h/yr; it also equals system efficiency, times system area, times available sunlight per unit area, because, for this kind of simple, nontracking system, downtime is negligible.



Table 1. Performance and cost indicators. (cont.)

INDICATOR NAME	UNITS	Base Case 1997		2000		2005		2010		2020		2030	
			+/-%		+/-%		+/-%		+/-%		+/-%		+/-%
<b>Capital Cost (1997\$)</b>													
Direct Module Production Cost	\$/m <sup>2</sup>	150-200	25	135-185	30	85-105	30	50-80	30	48-62	30	40-50	30
Power-Related BOS (converted from \$W <sub>p</sub> to \$/m <sup>2</sup> )	\$/m <sup>2</sup>	60	25	54	30	44	30	35	30	32	30	25	30
Area-Related BOS without Land	\$/m <sup>2</sup>	109	25	100	30	78	30	48	30	42	30	39	30
Land Costs (total system area basis)	\$/m <sup>2</sup>	0.4		0.6		0.8		0.8		1.2		1.2	
Indirect Cost Factor (on modules and systems)	multiple	1.3	50	1.21	50	1.16	50	1.1	50	1.1	50	1.11	50
Indirect Costs (on modules and systems)	\$/m <sup>2</sup>	100	50	66	50	35	50	15	50	13	50	11	50
System Total	\$/m <sup>2</sup>	445	30	380	35	252	35	163	35	142	35	120	35
<b>DC Unit Costs</b>													
Module Cost (w/overhead)	\$/W <sub>p</sub>	3.8	30	2.2	35	1.0	35	0.5	35	0.38	35	0.29	35
BOS Cost (w/overhead & land at \$0.02/W <sub>p</sub> )	\$/W <sub>p</sub>	3.7	30	2.1	35	1.3	35	0.7	35	0.53	35	0.43	35
System Total	\$/W <sub>p</sub>	7.5	30	4.3	35	2.3	35	1.2	35	0.91	35	0.72	35
System Total	\$/M	0.148	30	12.7	35	23	35	23	35	18	35	14	35
<b>AC Unit Costs</b>													
System Total Capital Cost	\$/W <sub>p</sub>	9.3	30	5.3	35	2.9	35	1.5	35	1.11	35	0.88	35
<b>Operations and Maintenance Cost</b>													
Maintenance (annual)	\$/m <sup>2</sup> -yr	2	30	1	30	0.5	50	0.4	50	0.3	50	0.3	50
O&M (AC unit costs)	¢/kWh	2.30	30	0.77	30	0.31	50	0.20	50	0.13	50	0.12	50
Total Annual Costs	\$/yr	666	30	33,000	30	46,000	50	57,000	50	38,000	50	36,000	50
Total Operating Costs	\$/yr	666	30	33,000	30	46,000	50	57,000	50	38,000	50	36,000	50

## Notes:

1. For each of the six time frames, estimates of uncertainty (+/- %) are provided.
2. Plant construction is assumed to require less than 1 year.
3. Module manufacturing and BOS costs, when given in units of \$/m<sup>2</sup>, do not include overhead. However, final costs are fully loaded when given in \$/W<sub>p</sub> units. The difference is the 'indirect costs' given as a separate line. This overhead is used to indicate the fully loaded BOS, module, and installed system costs.
4. Most direct costs are given as \$/m<sup>2</sup> because most costs are area-related (e.g., module manufacturing costs). Giving costs in terms of areas is a strong indicator of technical issues and evolutions. For example, critical parameters such as yield, materials use, and process rate are all proportional to module area produced.
5. Substantial uncertainties exist in both the magnitude and timing of the projections, since progress in PV depends critically on continued research advances. Long-term projections (2030) are based on reaching cost and performance that look practical, based on today's technologies and understanding. It is likely that actual 2030 achievements will be better than those assumed here because of innovations that are beyond what we can envision today.

## UTILITY-SCALE FLAT-PLATE THIN FILM PHOTOVOLTAICS

A key indicator is the projected efficiency of commercial modules. The output of a PV system is nearly proportional to the incident sunlight, and that proportionality is called the 'efficiency' of the system. Efficiency is defined for both energy and power. Power can be used as a measure of the instantaneous amount of sunlight on an array, or the amount of electric power the array produces (units of watts); energy is the power over a period of time (units of kWh). For example, if a PV system produces 180 kWh/m<sup>2</sup>-yr in an average U.S. location (with 1,800 kWh/m<sup>2</sup>-yr of sunlight), it is said to have an efficiency of 10% (since 180/1,800 is 10%). Similarly, if the instantaneous amount of sunlight is 1,000 W/m<sup>2</sup> (about the solar power at noon on a clear day; part of the definition of standard peak power conditions) and the PV system produces 100 W/m<sup>2</sup> of power, its efficiency is also 10%. Efficiency is the most critical figure of merit for PV, since both output and cost are strongly coupled to efficiency. Cost is inversely proportional to efficiency. A system installed for \$1,000 that produces 100 watts has a price of \$10/W (\$1,000/100 W). One that is twice as efficient in converting sunlight to electricity produces double the power (200 W) for the same \$1,000, and thus has half the price (per unit of power), or \$5/W.

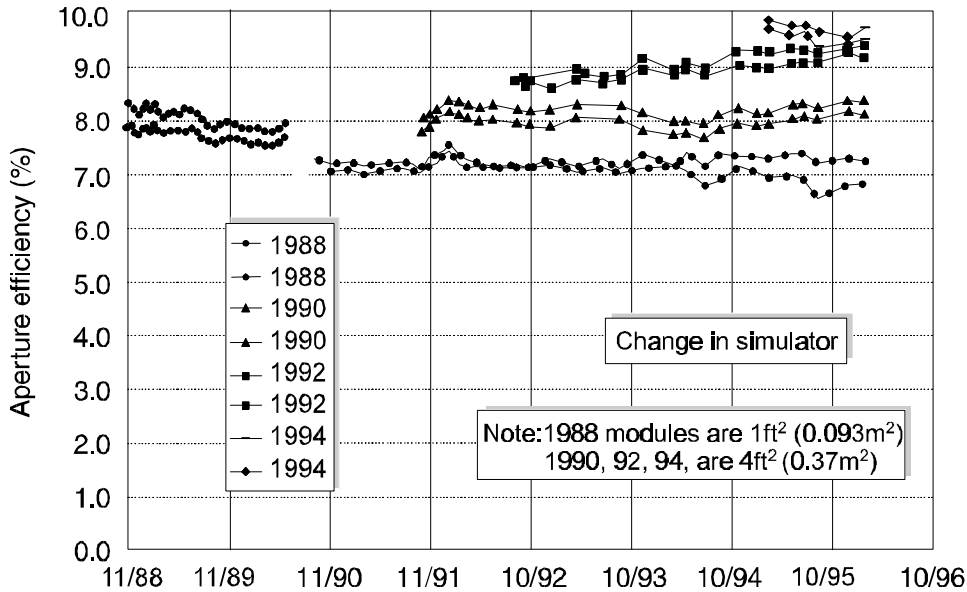

Figure 2. Results from eight years of outdoor thin film module tests.

More than a decade of technology development focused on thin films is beginning to pay off in the form of excellent performance. Table 2 shows the best 'one-of-a-kind', pre-commercial, thin film prototype modules [35,36]. These modules are the basis for our confidence in our cost and performance projections.

The base year (1997) status [18-20, 35-36] of thin films supports these projected levels. For example, cell-level efficiencies have reached 16-18% in two different polycrystalline thin films (copper indium diselenide and cadmium telluride; see Figure 3). Submodule and module efficiencies are closely related to cell efficiencies, with minor losses (about 10%) due to some loss of active area and some electrical resistance losses. Today's best laboratory-level modules are about 8-10% efficient (see Table 2). When the product-level technology (which includes all the process development needed for manufacture) has adopted all the technical capabilities now observed in laboratory experiments, the best lab modules will be about 90% of the efficiency of the best cells. Off-the-shelf commercial modules will be about 90% as efficient as the best prototype modules. The timing of how these R&D advances actually

## UTILITY-SCALE FLAT-PLATE THIN FILM PHOTOVOLTAICS

become available in the marketplace is far less certain; projected ranges are used to capture this uncertainty without completely begging the question.

Table 2. The best thin film modules (1997).

Thin Film Material	Size (cm <sup>2</sup> )	Efficiency (%)	Power (Watts)	Company & Comments
CdTe	6,728	9.1	61.3	Solar Cells Inc.
a-Si	7,417	7.6	56.0	Solarex (Amoco Enron Solar)
CIS	3,859	10.2	39.3	Siemens Solar Industries
CdTe	3,366	9.2	31.0	Golden Photon Inc.
a-Si	3,906	7.8	30.6	Energy Conversion Devices
a-Si	3,432	7.8	26.9	United Solar Systems (USSC)
a-Si	1,200	8.9	10.7	Fuji (Japan)
CIS	938	11.1	10.4	ARCO Solar (now Siemens Solar)
CdTe	1,200	8.7	10.0	Matsushita (Japan)
a-Si	902	10.2	9.2	USSC

Note: Efficiencies verified independently at NREL.

Submodules not shown in Table 2 have reached 13-14% at about 100 cm<sup>2</sup> in area [36]. Efficiencies are 10% to 11% on square-foot (0.093 m<sup>2</sup>) sizes, and 7% to 10% on larger power modules ranging in size from 4 to 8 square feet (0.37-0.74 m<sup>2</sup>) in area. A few years ago (1990), no thin film modules larger than four square feet (0.37 m<sup>2</sup>) were being made. The transition from laboratory-level cell prototypes to pre-commercial modules is underway. These same modules now form the basis for design and construction of larger-capacity manufacturing facilities, which are in-progress at many U.S. thin film companies. Meanwhile, additional technical progress is in the pipeline [36]. Figure 3 shows the recent progress in polycrystalline thin film laboratory cells. The changes implicit in the best 16-18% efficient cells have not yet been incorporated in the modules of Table 2. When they are, efficiencies will rise commensurately. The progress in thin film cells provides a strong basis for our belief that the ambitious performance goal of 15% for commercial modules will be met, since a reasonable translation of existing cell efficiencies to future module efficiencies would be nearly sufficient to meet the goal. Figure 2 shows outdoor tests of six CIS-based thin film modules at NREL. These modules have been outside for almost eight (8) years. They show no apparent change in performance. Two-year stability data is available for CdTe modules.

Module and system costs are frequently given in \$/m<sup>2</sup> as an indication that most PV costs are proportional to module area. (Some costs, such as those for inverters, are proportional to power, but can be converted to \$/m<sup>2</sup> using area and a known output per unit area). A module might have a fully loaded cost of \$400/m<sup>2</sup> to manufacture. If it produces 100 W/m<sup>2</sup> under 'standard conditions', it is said to have a cost of \$4/W<sub>p</sub> (W<sub>p</sub> stands for the watts produced under peak sunlight). Today's PV modules sell at about \$3.5 to \$5/W<sub>p</sub>; and PV systems sell at about \$7 to \$15/W<sub>p</sub>. Peak power

## UTILITY-SCALE FLAT-PLATE THIN FILM PHOTOVOLTAICS

for a system is found by adding up the power of the individual modules, rated at their peak power. System economics are then calculated based on kWh output during real or average conditions at a specific solar location.

The base year (1997) system is modeled after two recent thin film systems: an APS a-Si 400 kW system at PVUS A (\$5/W<sub>p</sub>) and a Solar Cells Inc./ 25 kW CdTe system at Edwards Air Force Base (\$6.3/W<sub>p</sub>, [37]). Although both of these systems are below the indicated \$7.4/W<sub>p</sub> that we assumed (see Table 1), it is probably proper to estimate that the companies installed them for somewhat below true cost.

Today, PV module costs are about half the total system costs for most PV systems and are the primary opportunity for cost reductions. The technology option considered here (thin films) was originally investigated because its potential cost per unit area is significantly lower than existing PV based on wafer silicon [16-20]. In addition to module cost, the module performance defines system output. This combined influence on capital cost and system unit output cost is why modules are the critical cost driver in PV. Structural costs are highly dependent on economies of volume production. They are expected to fall as production increases. But they, too, require some focused developmental work to reach optimal levels. However, module efficiencies and module manufacturing costs are the key areas of focus determining PV system costs. Work on improving PV modules (both in terms of efficiency and cost optimization) is most likely to pay off in reductions in PV prices.

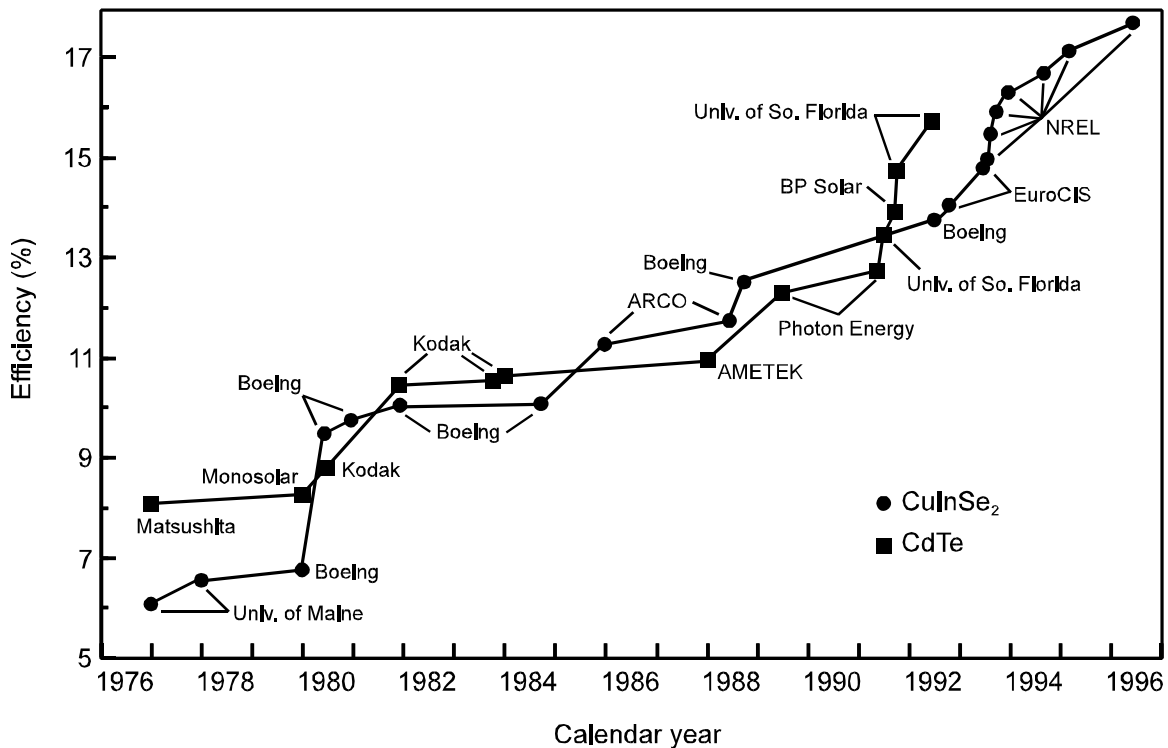

Figure 3. Recent progress in polycrystalline thin film laboratory cell efficiencies.

In terms of module production costs, various studies [22-32, 33] of materials costs, combined with energy inputs, labor, and capital costs, support the cost projections. Data on specific amorphous silicon and polycrystalline thin film

## UTILITY-SCALE FLAT-PLATE THIN FILM PHOTOVOLTAICS

technologies were provided by U.S. manufacturers to the DOE/NREL PV Manufacturing Initiative as part of their final reports [27-32]. These provide the most up-to-date information on module cost projections. General analysis of PV system costs can be found in References 38-40. Nearly all of these cost studies agree that ultimate thin-film module manufacturing costs for a future, optimized manufacturing scenario can be as low as \$40-\$50/m<sup>2</sup>. Since the issue of achieving very low module manufacturing costs, \$50/m<sup>2</sup> or less, is perhaps the most important of any aspect of these projections, it deserves some special focus. In-depth review of References 22-32 supports this assertion and reveals a few important aspects of cost that are summarized in Table 3.

Table 3. Summary of thin film direct manufacturing costs: projections for practical long-term reductions.

Summary of Thin Film Direct Manufacturing Costs	Cost (\$/m <sup>2</sup> )
Materials	
Glass (2 sheets @ \$5/m <sup>2</sup> )	10
Binder (between glass and module)	5
Active Materials (for PV thin film)	5
Subtotal: Materials	20
Capital equipment (manufacturing plant)	10
Energy used in manufacturing	2
Facilities	1
Labor	10
<b>TOTAL</b>	<b>43</b>

**Materials:** Most thin films use one or two pieces of inexpensive soda lime glass, which is sold in quantity at about \$5/m<sup>2</sup>. A sheet of binder (between the glass and the module) is about another \$5/m<sup>2</sup>. The amount of material in a micron thickness across a square meter of area is 1 cm<sup>3</sup>. There are about 3-10 g/cm<sup>3</sup> of material in the various films. Film thickness is about 1-10 μm, depending on the design, so a typical amount of material would be about 25 g/m<sup>2</sup>. Considering feedstock losses, if only 50% of the feedstock material actually ends up on the module, then 50 g/m<sup>2</sup> of feedstock are needed. Typical materials costs for the various materials used in thin films (at high purity) can vary from \$20 to \$200/kg, or \$0.02-\$0.20/g. Fifty grams would cost about \$5/m<sup>2</sup>. This is the total cost of the active materials in a thin-film module and is a fairly typical number from References 22-32 for all the materials costs outside the glass and encapsulants. The total materials costs are about \$20/m<sup>2</sup> (adding the active materials, binder, and two pieces of glass).

**Manufacturing Plant:** Thin film manufacturing plants are now being built or being planned. Their capital costs tend to fall into the range of \$10M to \$30M for 10 MW of annual production capacity (about 150,000 m<sup>2</sup> of modules at 6.5% efficiency). That is \$1-\$3/W<sub>p</sub> for first-year module production. If this cost is amortized over 5 years, this becomes \$0.3-0.8/W<sub>p</sub> for production costs (assuming a discount rate to take into account the time value of money). These costs must be translated into \$/m<sup>2</sup> to provide an insight into trends. Since today's module efficiencies are only 5%-8%, these plant costs are about \$18 to \$52/m<sup>2</sup> (assuming 65 W/m<sup>2</sup> multiplied by \$0.3/W or \$0.8/W). Today's first-ever manufacturing plants are quite rudimentary, from a technical standpoint. Capital costs can only get lower as processes are optimized for faster throughput and other economies of scale. A 'best' future capital cost of about half of today's lower costs, \$10/m<sup>2</sup>, seems quite conservative. (For example, tripling the throughput rate would cut the

## UTILITY-SCALE FLAT-PLATE THIN FILM PHOTOVOLTAICS

module unit cost attributable to plant capital ( $\$10/\text{m}^2$ ) by a factor of three. This kind of improvement is already being investigated at the lab level.)

**Energy, Labor and Facilities:** The remaining direct manufacturing cost components are energy, labor, and facilities. Various analyses of module energy input costs suggest that modules will pay back their energy output within one year of outdoor operation [41-42]. References 41 and 42 quantify the electrical energy in a thin film module as about 20 kWh/m<sup>2</sup>. At a price of  $\$0.1/\text{kWh}$ , this is another  $\$2/\text{m}^2$ .

Adding all of the costs so far, yields  $\$32/\text{m}^2$ . Facilities costs are about  $\$200,000/\text{year}$  for a 10 MW plant, or  $\$0.02/W_p$ , which is  $\$1.3/\text{m}^2$  (nearly negligible). Labor costs are the last item of significance. We estimate that an operational plant with reasonable automation would require about 10 operators/shift; 30 full time staff. These are technician and operations-level positions. (Management and marketing, as well as other indirect costs, are included in overhead costs.) At direct costs of  $\$50,000/\text{yr}$ , they would cost about  $\$1,500,000/\text{yr}$ , or  $\$0.15/W_p$ , or  $\$10/\text{m}^2$ . Adding together these estimates yields ( $\$20/\text{m}^2$  for materials;  $\$10/\text{m}^2$  for capital equipment;  $\$2/\text{m}^2$  for energy;  $\$1/\text{m}^2$  for facilities; and  $\$10/\text{m}^2$  for labor)  $\$43/\text{m}^2$ . This number is both close to estimates of 'best future' manufacturing costs (about  $\$40/\text{m}^2$ ) and also without the full value of the following optimizations: thinner semiconductors, improved materials use during deposition, higher-rate deposition processes, better yields, larger-sized or continuous substrates, reduced input energy and substrate costs by either eliminating one sheet of glass or attaching PV production on the end of a glass line, and complete automation of these rather straightforward in-line processing steps. All of these steps are obvious technological improvements that are already underway in various forms, but their potential for improvement is far from being exhausted.

The  $\$/W_p$  costs in Table 2 are simple restatements of these costs from a  $\$/\text{m}^2$  basis ( $\$/\text{m}^2$  divided by  $W_p/\text{m}^2$  yields  $\$/W_p$ ). Total system output is about 20% less than peak power rating due to operational de-rating (operating temperature, resistance and power-conditioning losses) [39,43]. Installed system costs are assumed to be about twice as high as module costs (assuming that increased volume production of systems will result in balance-of-system (BOS) cost reductions that parallel module cost reductions). BOS, or balance of system, costs are the costs associated with everything but the modules and overhead; i.e., land, support structures, module wiring, power conditioning and DC-to-AC inverter, installation, and transportation. Total system cost is the module cost, the BOS cost, plus overheads. Overheads occur at all levels, from overheads on manufacturing the modules and BOS components, to system design and installation overheads.

The overhead and BOS costs are expected to decline because the cost of today's systems is the sum of rather low material costs, fairly high DC-AC inverter costs, and very substantial design, engineering, and installation costs for doing different, small systems one at a time. Improvements in inverters have already been observed in other renewables (e.g., wind) when inverter sizes are large. Inverter costs in-line with those needed for low-cost PV have been achieved in these cases. Similarly, the other aspects of systems costs (design, engineering, installation, overhead) are all likely to fall substantially as volumes and repetition increase. Many PV industry representatives believe that the material costs in real PV BOS will be compatible with very low ultimate costs like those quoted here.

## UTILITY-SCALE FLAT-PLATE THIN FILM PHOTOVOLTAICS

### 5.0 Land, Water, and Critical Materials Requirements

Table 4. Resource requirements.

Indicator Name	Units	Base Year					
		1997	2000	2005	2010	2020	2030
Land	ha/MW	5	4	3	2.5	2.5	2.5
	ha	0.08	9.6	24	40	40	40
Critical elements (e.g., In, Se, Ga, Te)	MT/GW <sub>p</sub>	NA	50	30	20	10	3
Water	m <sup>3</sup>	nil	nil	nil	nil	nil	nil

Land area needs are based on calculating the array area required to produce the desired output, amount of energy per square meter of array and then multiplying this area by a factor of about 2.5 to account for packing the arrays without shadowing. At 10% system efficiency, a PV system produces about 100 W/m<sup>2</sup> of array. Including the packing factor, this is 40 W/m<sup>2</sup> of land area. A MW would thus require 25,000 m<sup>2</sup> of land, or about 0.025 km<sup>2</sup>. In the early years, we expect system efficiency to be below 10% (accounting for the larger land requirements), but by 2010, system efficiency of over 10% is assumed (accounting for the lower land-use numbers). In some cases, PV will be used on rooftops or other dual-use applications, thus reducing land use below these estimates.

Certain PV technologies require important elements such as tellurium, indium, selenium, and gallium. The availability of these materials is, in principle, limited by economics and geologic factors. However, thin film PV uses very small amounts. Typical elemental concentrations in PV are about 3 g/m<sup>2</sup> for each micron of layer thickness. Layer thicknesses vary from about 1-3 μm. In early years, little effort will be put into reducing thicknesses, because even at these thicknesses materials costs are not a driver. But as performance increases and other costs are overcome, materials costs will become important, and layers will be thinner. The theoretical limit on how thin layers can be (from today's understanding) is about 0.1-0.3 μm, depending on device subtleties such as light trapping to cause multiple reflections. This evolution of materials needs is captured in Table 4 (above) based on reduced layer thickness (coming down from about 2 μm to about 0.2 μm) and efficiency (output per g of feedstock) rising from 8% to 15%. In no case would the very large-scale use of PV put pressure on the availability of these elements. Indeed, this also means that other materials that are used in compound semiconductors (e.g., cadmium in CdTe) would not be used excessively, obviating most global-level environmental impacts of these materials. For example, cadmium is used today at about 20,000 MT/yr for current uses (rechargeable batteries for entertainment). Using 100 MT/yr for PV (to add over 30 GW<sub>p</sub>/yr of PV capacity) would change this usage by less than 0.5%.

Ultimately, as PV reaches a steady-state, recycling of outdated thin film modules would allow for another reduction by half in the amounts of new material needed to make a GW<sub>p</sub> per year of PV. In fact, the use of materials is so controlled in PV systems (semiconductors are sealed from the environment for 30 years or more and can then be recycled), that PV may ultimately play a role as a safe and productive 'sink' for numerous materials that are today without any long-term sequestering strategy.

PV systems do not use water during operation.

## UTILITY-SCALE FLAT-PLATE THIN FILM PHOTOVOLTAICS

### 6.0 References

1. Solar Radiation Data Manual for Flat Plate and Concentrating Collectors, National Renewable Energy Laboratory, Golden, CO: April 1994. Report TP-463-5607.
2. Shugar, D., "PV in the Utility Distribution System: The Evaluation of System and Distributed Benefits, " Proceedings of the 21st IEEE PV Specialists Conference, Kissimmee, FL (May 1991).
3. Alsema, E.A., and B.C.W. van Engelenburg, "Environmental Risks of CdTe and CIS Solar Cell Modules, " Proceedings of the 11th European Solar Energy Conference, Montreux (October 12-16, 1992).
4. "Energy System Emissions and Material Requirements," Meridien Research Inc., Needham, MA: 1989.
5. Proceedings of the 25th IEEE PV Specialist Conf., Washington, D.C. (1996). Moskowitz, P.D., and V.M. Fthenakis, "Toxic Materials Released from PV Modules during Fires: Health Risks," Solar Cells, 1990.
6. Moskowitz, P.D., V.M. Fthenakis, L.D. Hamilton, and J.C. Lee, "Public Health Issues in PV Energy Systems : An Overview of Concerns," Solar Cells, 1990, pp. 287-299.
7. Moskowitz, P.D., W.M. Fthenakis, and K. Zweibel, "Health and Safety Issues Related to the Production, Use , and Disposal of Cd-Based PV Modules," Proceedings of the 21st IEEE PV Specialist Conference, Kissimmee , FL (May 1990)
8. Moskowitz, P.D., L.D. Hamilton, S.C. Morris, K.M. Novak, and M.D. Rowe, Photovoltaic Energy Technologies: Health and Environmental Effects Document, Brookhaven National Laboratory, Upton, NY: 1990. Report BNL-51284.
9. Moskowitz, P.D., and K. Zweibel, eds., Recycling of Cadmium and Selenium from PC Modules and Manufacturing Wastes: A Workshop Report, Brookhaven National Laboratory, Golden, CO: March 11-12 1992. Report BNL 47787.
10. Moskowitz, P.D., K. Zweibel, and V.M. Fthenakis, Health, Safety, and Environmental Issues Relating to Cadmium Usage in PV Energy Systems, Solar Energy Research Inc., Golden, CO: 1990. Report SERI/TR-211-3621.
11. San Martin, R.L., Environmental Emissions from Energy Technology Systems: Total Fuel Cycle, U.S. Department of Energy, April 1989.
12. Tolley, W.K., and G.R. Palmer, "Recovering Cadmium and Tellurium from CdTe Manufacturing Scrap, " Proceedings of the 1991 AIME Annual Meeting, New Orleans, LA (February 1991).
13. Moskowitz, P.D., National PV Environmental, Health and Safety Information Center: Bibliography, Brookhaven National Lab, Upton, NY: 1993. Report 11973.
14. Golden Photon Inc., and Solar Cells Inc., Proceedings of the 12th NREL PV Program Review Meeting, Golden , CO (October 1993).



## UTILITY-SCALE FLAT-PLATE THIN FILM PHOTOVOLTAICS

15. Stone, J.L., E. Witt, R. McConnell, and T. Flaim, Proceedings of 17th IEEE PV Specialists Conference, Kissimmee, FL (May 1984).
16. Johansson, T.B., H. Kelly, A.K.N. Reddy, and R.L. Williams, eds., Renewable Energy Sources for Fuels and Electricity, Island Press, Washington, D.C., 1993, pp. 1160.
17. Luft, W., and Y.S. Tsuo, Hydrogenated Amorphous Silicon Alloy Deposition Processes, Marcell Dekker Inc., New York, NY, 1995.
18. Witt, C.E., M. Al-Jassim, and J. Gee (eds.) "NREL/SNL PV Program Review," Proceedings of the 14<sup>th</sup> Conference, Lakewood, CO, AIP Conference Proceedings 394, American Institute of Physics, Wookbury, NY, 1997, pp. 3-171, 445-463, 537-709, 881-892.
19. Ullal, H.S., K. Zweibel, and B.Von Roedern, "Current Status of Polycrystalline Thin Film PV Technologies," 26<sup>th</sup> IEEE PV Specialists Conference, Anaheim, CA, October 1997 (also, NREL/CP-520-22922, NREL, Golden, CO, 1997).
20. Zweibel, K., "The Progress of Polycrystalline Thin Film PV," American Scientist, April 1993.
21. Zweibel, K., Harnessing Solar Energy, Plenum Publishing, New York, NY, 1990, pp. 319.
22. Russell, T.W.F., B.N. Baron, and R.E. Rocheleau, "Economics of Processing Thin Film Solar Cells," J. Vac. Sci. Technology. Vol. B2, No. 4, pp. 840-844 (October-December 1984).
23. Jackson, B., CdZnS/CuInSe<sub>2</sub> Module Design and Cost Assessment, Solar Energy Research Institute, Golden, Co: September 1985. Report SERI/TP-216-2633.
24. Meyers, P.V., Polycrystalline Cadmium Telluride n-i-p Solar Cells, Solar Energy Research Institute, Golden, Co: March 1990. Report SERI/ZL-7-06031-2.
25. Kapur, V.K., and B. Basol, "Key Issues and Cost Estimates for the Fabrication of CIS PV Modules by the Two-Stage Process," Proceedings of at the 21st IEEE PV Specialists Conference, Kissimmee, FL (May 1990).
26. Zweibel, K., and R. Mitchell, CuInSe<sub>2</sub> and CdTe Scale-up for Manufacturing, Solar Energy Research Inc., Golden, CO: December 1989. Report SERI/TR-211-3571.
27. Wohlgemuth, J.H., D. Whitehouse, S. Wiedeman, A.W. Catalano, and R. Oswald, Final Report for P V Manufacturing Technology Phase I (Jan.-April 1991), Solarex Corporation: December 1991. Report NREL/TP-214-4483.
28. Izu, M., Final Report for PV Manufacturing Technology Phase I (Jan.-April 1991), Photon Energy Inc.: March 1992. Report NREL/TP-214-4579.
29. Albright, S., Final Report for PV Manufacturing Technology Phase I (Jan.-April 1991), Photon Energy Inc.: November 1991. Report NREL/TP-214-4569.

## UTILITY-SCALE FLAT-PLATE THIN FILM PHOTOVOLTAICS

30. Stanbery, B.J., Final Report for PV Manufacturing Technology Phase I (Jan.-April 1991), Boeing Aerospace & Electronics: November 1991. Report NREL/TP-214-4606.
31. Jester, T., Final Report for PV Manufacturing Technology Phase I (Jan.-April 1991), Siemens Solar Industries : November 1991. Report NREL/TP-214-4481.
32. Brown, J., Final Report for PV Manufacturing Technology Phase I (Jan.-April 1991), Solar Cells Inc.: November 1991. Report NREL/TP-214-4478.
33. Wagner, S., and D.E. Carlson, "Amorphous Silicon Solar Cells", Proceedings of the 10th E.C. Photovoltaic Solar Energy Conference, pp. 1179-1183 (1991).
34. DeBlasio, R., L. Mrig, and D. Waddington, "Interim Qualification Tests and Procedures for Terrestrial PV Thin Film Flat Plate Modules," Proceedings of the 22nd IEEE PV Specialist Conference, Las Vegas, NV (October 1991).
35. Zweibel, K., "Thin Films: Past, Present, and Future," Progress in PV, The Future of thin Film Solar Cells. Vol . 3, No. 5, pp. 279-294 (Sept. 1995).
36. Zweibel, K., H.S. Ullal, and B. von Roedern, "Progress and Issues in Polycrystalline Thin Film PV Technologies," Proceedings of the 25th IEEE PV Specialists Conference, Washington, DC (May 1996).
37. Edwards, H.S., G.D. Smith, G. Voecks, N. Rohatgi, P. Prokopius, and K. Zweibel, "CdTe Terrestrial Modules as a Power Source for a Regenerative Fuel Cell Power Plant for Space Applications," Proceedings of the 25th IEEE PV Specialists Conference, Washington, DC (May 1996).
38. U.S. Department of Energy, National PV Program, Five Year Research Plan 1987-1991, PV: USA's Energy Opportunity, DOE/CH10093-7, May 1987.
39. Taylor, R.W., PV Systems Assessment: An Integrated Perspective, Electric Power Research Institute, Palo Alto , CA: 1985. Report EPRI/AP-3176-SR.
40. Awerbach, S., "Measuring the Costs of PV in an IRP Framework," Proceedings of the DOE-NARUC 4th National Conference on Integrated Resource Planning, Burlington, VT (September 1992).
41. Hay, K., J.D.L. Harrison, R. Hill, and T. Riaz, "A Comparison of Solar Cell Production Technologies Through their Economic Impact on Society," Proceedings of the 15th IEEE PV Specialist Conference, Kissimmee, FL (May 1981).
42. Haynes, K.M., A.E. Baumann, and R. Hill, "Life Cycle Analysis of PV Modules Based on CdTe," Proceedings of the 12th EC PV Solar Energy Conference, Amsterdam (1994).
43. PV System Assessments: An Integrated Perspective, Electric Power Research Institute, Palo Alto, Ca: 1983. Report EPRI/AP-3176-SR.

# UTILITY-SCALE PHOTOVOLTAIC CONCENTRATORS

## 1.0 System Description

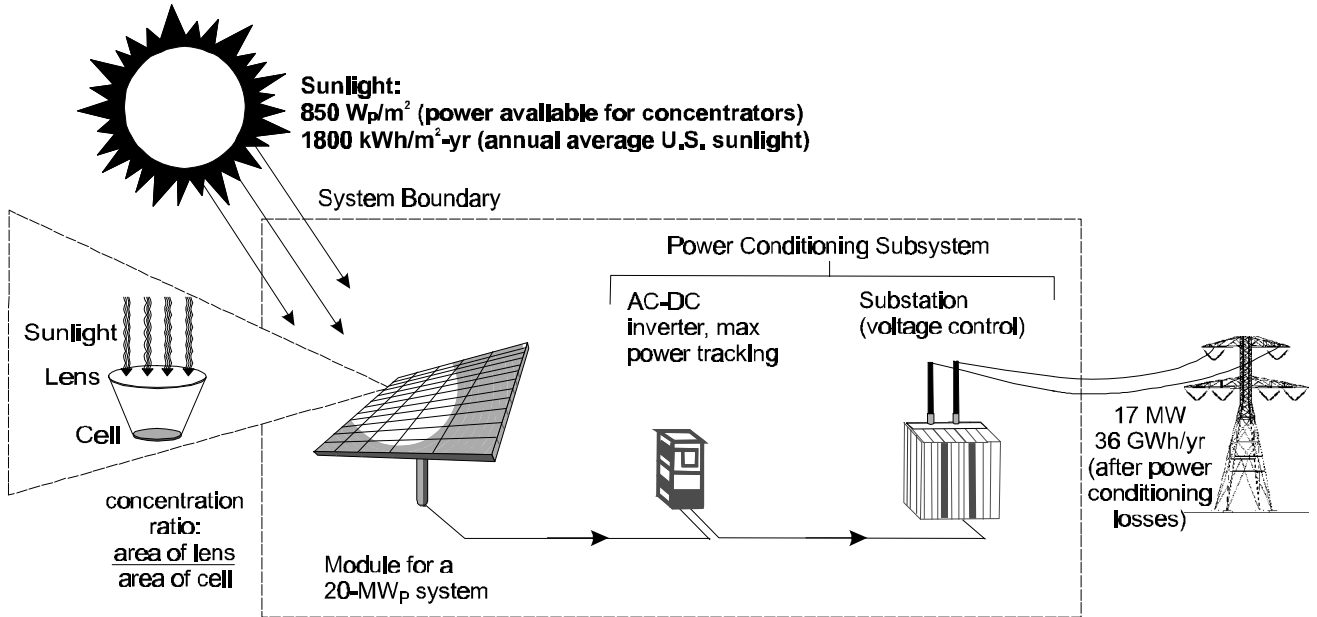

Figure 1. Grid-connected photovoltaic concentrator system schematic.

Photovoltaic concentrator systems use optical concentrators to focus direct sunlight onto solar cells for conversion to electricity. Figure 1 shows a PV concentrator system connected to a utility grid that eventually provides power to customers. The complete system includes concentrator modules, support and tracking structures, a power processing center, and land. PV concentrator module components include solar cells, an electrically isolating and thermally conducting housing for mounting and interconnecting the cells, and optical concentrators. The solar cells in today's concentrators are predominantly silicon, although gallium arsenide (GaAs) solar cells may be used in the future because of their high-conversion efficiencies. The housing places the solar cells at the focus of the optical concentrator elements and provides means for dissipating excess heat generated in the solar cells. The optical concentrators are generally Fresnel lenses but can also be reflectors. Except for low concentrations, below about 10 suns, optical concentrators can use only the direct normal, non-diffuse, portion of the incident solar radiation. The modules are mounted on a support structure and, during daylight hours, are oriented to face (or "track") the sun using motors, gears, and a controller. Tracking the sun is necessary for high concentration (above approximately 10 "suns" or 10x) and increases the amount of energy captured daily, more than compensating for the losses due to inability to convert diffuse radiation. The concentrator module output flows to a power-processing center that includes hardware to convert power from direct current (DC) to alternating current (AC), safety devices, and controls to interface properly with the utility grid or other load.

By using optical concentrators to focus direct sunlight onto solar cells, the cell area, and consequently cell cost, can be reduced by a factor of up to one thousand (a 1,000x concentration factor). The solar-cell cost constitutes between 5% and 10% of total concentrator system cost. More expensive cells, costing even hundreds or thousands of dollars more per unit area than 1-sun cells used in flat plate systems, can still be cost effective in concentrators. Moreover,

## UTILITY-SCALE PHOTOVOLTAIC CONCENTRATORS

because properly designed concentrator cells are already significantly more efficient than 1-sun cells, concentrator s have always been a promising high-efficiency photovoltaic option.

### 2.0 System Application, Benefits, and Impacts

An important characteristic of concentrator technology is the potential for rapid scaleup. Except for the solar cells, the remaining concentrator components are readily available from metal, plastic, glass, and electrical fabricators and suppliers. Concentrators also offer the benefit of having no effluents or emissions during operation. The effluent s resulting from cell manufacture are lower, by the concentration factor, than those of flat-plate (one-sun) solar cells . Further, if the availability of polysilicon feedstock becomes an issue for the crystalline-silicon photovoltaic industry , the fact that concentrators use one hundred to one thousand times less silicon than flat-plate systems may become important [1].

Sales of concentrating systems are less than 1 percent of all photovoltaic system sales. Concentrators are not well suited to small applications where most of these PV sales have been made, and the very large application of concentrators as utility power plants requires low cost from the beginning. Concentrators have additional burdens compared to flat-plate systems. Concerns over tracking-system reliability are added to concerns over their obtrusive appearance and more restrictive mounting options. They are difficult to integrate into residential roofs, for example.

Knowing that concentrators cannot compete in certain markets amenable to small flat-plate PV systems does not mean they cannot compete in other markets. High-efficiency concentrators will be stiff competition for other PV technologies in medium-scale power applications in good solar-resource regions [2]. However, even though some applications favor PV concentrator over flat-plate systems, or vice versa, the most significant competition in the U.S. for either is natural gas.

### 3.0 Technology Assumptions and Issues

This characterization is based on the current state of worldwide concentrator development. There are at least 10 companies developing or manufacturing concentrator systems [3]. Three of the U.S. concentrator companies are actively marketing their systems. The variety of technologies is extensive, as shown in Table 1.

Given the variety of technologies shown in Table 1, the selection of a base-case concentrator for this characterization is somewhat arbitrary. A recent assessment included near-term estimates for a variety of concentrator technologies [2]. These include:

- 1-axis-tracking parabolic trough at 50x A polar-axis tracking reflective trough with 50x concentration on a silicon photovoltaic receiver.
- Static (non-tracking) concentrator A static concentrator with concentration of 4x is assumed. It is mounted south-facing with latitude slope. This concept, although not part of this technology characterization, was found to be a low-cost option comparable with either flat-plate thin film or high concentration PV modules. The Japanese PV program recently started a new research effort into static concentrators.

## UTILITY-SCALE PHOTOVOLTAIC CONCENTRATORS

Table 1. Current concentrator technology development efforts.

Concentrator Type	Concentration Factor	Cell Type	Comments
Linear Fresnel lens	20x	Silicon	Mature 4th generation design
Linear Fresnel lens	15x	1-sun Si	Collects some diffuse light and uses simple tracker
Point-focus Fresnel lens	250x	High efficiency Si	Uses reflective secondaries, projects less than \$2/W in high volume
Point-focus Fresnel lens	250x	High efficiency Si	Glass lens and advertises \$3/W for field larger than 500 kW
Point-focus Fresnel lens	300x	Si	Developed small 230 W module competitive with flat plate modules
Dish	2400x	Si or GaAs	Cogeneration approach produces thermal energy and electricity, 1 kW system completed
Dish	500x	Si	Cogeneration, demonstrated proof of concept
Reflecting Parabolic Trough	25x and 32x	Si	Two different manufacturers
Innovative Optics	10x	Si or Other	Spectrally selects light, non-tracking
Linear Focus	2-10x	CuInSe <sub>2</sub>	Innovative solar cell filaments, tracking and nontracking

- Point-focus or dish concentrator at 400x using Si A reflective dish or a Fresnel lens using high-efficiency silicon concentrator cells operating at a concentration of 400x. The analysis is not accurate enough to distinguish between these two optical concentrators.
- A point-focus or dish concentrator at 1,000x using GaAs This is a system similar to the above, but the silicon cell is replaced with a very high-efficiency multijunction cell based on III-V (gallium arsenide-related) materials.

Of these approaches, the 1-axis-tracking parabolic trough at 50x is assumed for the baseline because it is the most similar to concentrators available in today's market. Today's cost for this generic base system, estimated at \$7.55 per DC watt (see Table 2), is clearly justifiable since some companies expect their systems would sell for considerably less under certain conditions (see Table 1). The point focus optical concentrator was chosen for future cost estimates because it shows some cost advantage over other concentrator technologies and it is under development by several of today's manufacturers (see Table 1). Projections for concentrator technologies beyond 2010 are highly uncertain, in part because both DOE and EPRI terminated concentrator development in the early 1990s. Some government funding opportunities are still available under such programs as Photovoltaic Manufacturing Technology (PVMaT) and Technology Experience to Accelerate Markets in Utility Photovoltaics (TEAM-UP) [3]. Nevertheless, an industry

## UTILITY-SCALE PHOTOVOLTAIC CONCENTRATORS

group (the PV Concentrator Alliance) pursuing the commercialization of concentrator components and systems, states that a role for the government in the development of their industry is necessary. The Alliance believes the government should provide technical support for improving system performance, system reliability, and standards. Furthermore, the Alliance believes the federal government should provide long-term support for R&D into higher-efficiency cells, better optics, more-robust modules, reliable sun-tracking arrays, novel concentrator applications, and new ideas for next-generation concentrators [4]. The Alliance also supports and encourages various government programs that promote renewable energy through tax incentives, market development, pollution credits, and green marketing.

In summary, this is a “best future” assessment of PV concentrator technologies, especially for the years following 2010. The performance (and costs) for these later years are subject to considerable uncertainty, especially in light of almost nonexistent government funding. Nevertheless, the existence of U.S. PV concentrator companies is evidence of their belief (and that of their investors) in the potential of this technology.

### 4.0 Performance and Cost

Table 2 summarizes the performance and cost indicators for the photovoltaic concentrator system being characterized in this report.

#### 4.1 Evolution Overview

The concentrator systems characterized here evolve from a 1-axis trough using silicon cells and 50x concentration, to a two-axis tracking point focus system using silicon cells at 400x, and finally to using very-high-efficiency GaAs solar cells in a point focus optical concentrator at 1,000x. The base system is similar to products on the market, although it does not represent the design of a particular manufacturer.

#### 4.2 Performance and Cost Discussion

The AC, grid-connected systems characterized here range in size from 20 kW to 80 MW. The systems and cells vary, just as they presently vary from company to company. The annual solar energy is that used in Reference 2 originally taken from the NREL Solar Radiation Data Manual for Flat-Plate and Concentrating Collectors [5]. This manual provides annual solar energy available for various tracking and non-tracking modules in different U.S. locations. The high-sunlight case uses Albuquerque, New Mexico insolation data where the total horizontal (0° tilt) value is 2,044 kWh/m<sup>2</sup>-yr. The average sunlight case corresponds to a central U.S. location (e.g. Wichita, Kansas) where the total horizontal value is 1,680 kWh/m<sup>2</sup>-yr. Table 2 shows the slight difference in annual solar energy available for 1-axis-tracking and 2-axis-tracking systems. The standard direct-normal incidence is 850 W/m<sup>2</sup> for concentrators and is the key factor in determining the module area in plant size. The AC capacity factors are therefore a direct result of system efficiency and annual solar energy for the particular concentrator technology. These capacity factors are consistent with those used in recent EPRI and DOE technology evaluations [6]. Note that the capacity factors depend on the site. Reference 2 used high-sunlight (Albuquerque) and low-sunlight (Boston ~ 1,300 kWh/m<sup>2</sup>-yr), with the low-sunlight case resulting in AC capacity factors of 17% to 18%. Note also that the temperature-derating factor is important for concentrators because cells may be operating at temperatures as high as 65 °C (149°F), whereas cell efficiencies are referenced to 25 °C (77°F). The temperature-derating factors are from Reference 2.

Table 2. Performance and cost indicators.

INDICATOR NAME	UNITS	Base Case		2000		2005		2010		2020		2030	
		1997	+/- %		+/- %		+/- %		+/- %		+/- %		+/- %
PV Concentrator		Si 1-axis Trough		Si Point Focus		Si Point Focus		GaAs Point Focus		GaAs Point Focus		GaAs Point Focus	
Concentration	x suns	50		400		400		1,000		1,000		1,000	
Plant Size (DC Rating)	MW <sub>p</sub>	0.02		3		10		20		40		80	
Plant Size (AC Rating)	MW	0.017		2.55		8.5		17		34		68	
Plant Size (Module Area)	1000 m <sup>2</sup>	0.145		20		58.5		92.2		164.6		304.2	
Performance													
Cell Efficiency	%	20		23		26		33		37	5	40	5
BOS Efficiency	%	85		85		85		85		85		85	
Optical Efficiency	%	90		85		85		85		85		85	
Temperature Derating	%	90		91		91		91		91		91	
System Efficiency	%	13.8		15.1		17.1		21.7		24.3	5	26.3	5
Average Solar Energy Site (direct normal insolation)													
Annual Solar Energy	kWh/m <sup>2</sup> -yr	1,674		1,800		1,800		1,800		1,800		1,800	
AC Capacity Factor	%	22.5		24.2		24.2		24.2		24.2		24.2	
System Annual Energy/Area	kWh/m <sup>2</sup> -yr	231		272		308		391		437		473	
Total Annual Energy Delivery	GWh/yr	0.033		5.4		18		36		72		144	
High Solar Energy Site (direct normal insolation)													
Annual Solar Energy	kWh/m <sup>2</sup> -yr	2,219		2,397		2,397		2,397		2,397		2,397	
AC Capacity Factor	%	29.5		32.2		32.2		32.2		32.2		32.2	
System Annual Energy/Area	kWh/m <sup>2</sup> -yr	306		360		410		520		582		630	
Total Annual Energy Delivery	GWh/yr	0.044		7.2		24		47.9		95.8		191.6	

Table 2. Performance and cost indicators (cont.)

INDICATOR NAME	UNITS	Base Case		2000		2005		2010		2020		2030	
		1997	+/- %		+/- %		+/- %		+/- %		+/- %		+/- %
PV Concentrator		Si 1-axis Trough		Si Point Focus		Si Point Focus		GaAs Point Focus		GaAs Point Focus		GaAs Point Focus	
Capital Cost													
PV Module Cost	\$/m <sup>2</sup>	160		160		90		90		80		80	
Tracking Cost	\$/m <sup>2</sup>	40		67		35		35		25		25	
Power-Related BOS	\$/W <sub>p</sub>	.7		.6		.3		.3		.2		.15	
Area-Related BOS w/o Land Costs	\$/m <sup>2</sup>	200		140		70		70		50		50	
Cell Cost per Cell Area	(\$1000)/m <sup>2</sup>	15		20		15		30		20		15	
Indirect Cost on modules and systems (% added to above costs, not including land)	%	30		20		20		15		15		10	
Land Cost	\$/m <sup>2</sup>	0.5		0.5		0.5		0.5		0.5		0.5	
Total Capital Cost	\$M	.151	10	12.2	10	20.1	20	31	30	44	40	71	50
Total Capital Cost per Peak Rated DC Power	\$/W <sub>p</sub>	7.55	10	4.01	10	2.01	20	1.55	30	1.1	40	.89	50
Total Capital Cost per Peak Rated AC Power	\$/W <sub>p</sub>	8.88		4.78		2.36		1.82		1.3		1.04	
Operation and Maintenance Cost													
Annual O&M	\$/kWh	.047		.02		.01		.008		.006		.004	
Annual O&M	\$/m <sup>2</sup> -yr	14		7		4		4		3.5		2.5	
Annual O&M	(\$1000)/yr	2.03		140		234		369		576		761	
Unit Annual O&M (AC rating)	\$/kW-yr (AC)	119		56		28		23		17		11	

Notes:

1. The columns for “+/-%” refer to the uncertainty associated with a given estimate.
2. Plant construction is assumed to require less than 1 year.



## UTILITY-SCALE PHOTOVOLTAIC CONCENTRATORS

One factor supporting the potential rapid evolution of concentrators is the existence of high-efficiency silicon solar cells, recently-developed very-high-efficiency gallium arsenide solar cells, and the prospect for continued increases in solar cell efficiency. Silicon-cell efficiencies of more than 26% have already been demonstrated by one U.S. concentrator manufacturer. DOE and EPRI concentrator programs have demonstrated stable, outdoor, module efficiencies of 18% from commercial production lines for high-concentration silicon cells [7, 8]. In 1994, NREL demonstrated a GaInP/GaAs monolithic two-terminal tandem cell with an efficiency greater than 30% at 140-180 suns, and greater than 29% at 400 suns [3]. The development of this device was the result of ten years' effort starting from an early 10% efficiency in 1985 to the 30% value in 1994 [9]. DOE's Five Year Research Plan has a milestone in 1999 for a 32% monolithic device, and a four-terminal tandem cell has been measured at 34% under 100x [10,11]. Because theoretical upper limits are much higher, and there are several approaches for achieving efficiencies as high as 40% by 2030 or earlier [11], there is considerable expectation that higher efficiencies will be achieved. The primary ongoing obstacle for concentrators is a slowly developing market that impedes progress toward lower-cost systems. The uncertainties shown in Table 2 are 10 times larger for cost estimates in 2030 than they are for performance (efficiency). Nevertheless, all uncertainties in Table 2 are simply estimates since these technologies are not mature enough for more formalized engineering cost calculations.

Another factor that may affect the future evolution of concentrator cells and systems is the intense interest and investment of the space PV community. Space cell companies have recently installed large production facilities for GaInP/GaAs cells to be used in worldwide satellite telecommunications projects. The space PV community is looking at using PV concentrators, which show increased resistance to high-energy radiation damage because their cells are sheltered inside other components.

U.S. PV concentrator companies are pursuing a wide variety of technological approaches. Concentrating optics vary from static concentrators, to low concentration systems with one-axis or two-axis tracking, to high concentration systems that concentrate more than a thousand-fold [4]. Both reflective and refractive optics are used, and new approaches such as holographic and graded-index optics are under development. The potential of static concentrators has recently been identified, suggesting exploration is warranted to find a cost-effective, practical design [2]. Cell materials range from the industry standard—silicon—to new materials such as gallium arsenide or copper indium selenide. These facts indicate that the technology is still evolving.

Another aspect of the future evolution of concentrators is that less capital is required for commercial scaleup because most of the system comprises readily available construction materials such as metal, glass, and plastic. PV concentrator technology could respond quickly to a drastic increase in demand for PV power plants—similar to the dramatic growth in the wind-energy industry in the 1980s. The cells are currently available at acceptable cost, and many system approaches are under development or in the marketplace, such as one producing both heat and electricity as well as a small concentrator system (230 W) beginning to compete in markets where certain flat-plate PV would previously have been the likely choice. These system developments may facilitate rapid commercialization into intermediate-sized applications, such as water pumping, island power, utility grid support, and remote housing.

Reference 2 assessed the various concentrator technologies over a time period ranging from a few years to a little over 10 years further out. Costs to 2010 are therefore based on the technology assessment in Reference 2. EPRI has conducted economic analyses for 2000–2005 that are consistent with the cost estimates in Table 2 [12]. Because of tremendous uncertainty in market projections for concentrators, no learning curve factors are used for the 2020 and 2030 estimates. The reductions that are shown are reasonably small decreases in module, tracking, BOS, and cell costs consistent with cost limits for materials.

## UTILITY-SCALE PHOTOVOLTAIC CONCENTRATORS

Operation and maintenance costs begin with recent costs for early startup systems [13] and progress to those expected for future mature technologies [6]. The recent (base-case) O&M cost is adjusted slightly for the capacity factor difference between the test site and the high solar energy site used in this study.

### 5.0 Land, Water, and Critical Materials Requirements

Table 3. Resource requirements.

Indicator Name	Units	Base Year					
		1997	2000	2005	2010	2020	2030
Land	ha/MW	4.3	3.9	3.4	2.7	2.4	2.2
	ha	0.07	10	29.3	46.1	82.3	152.1
Silicon	kg/MW	245	28	25	-	-	-
GaAs	kg/MW	-	-	-	18	16	15
Water	m <sup>3</sup>	0	0	0	0	0	0

The land requirement calculations shown in Table 3 assume the module area under plant size in Table 2 is 20% of land area, which corresponds to a 20% packing factor [14]. The module area is calculated using the AC rating under plant size, system efficiency, and the direct-normal insolation standard of 850 W/m<sup>2</sup>. Silicon requirements are based on information in Reference 15, leading to 1.44 kg/m<sup>2</sup> of silicon feedstock needed per wafer area or 3.29 kg/m<sup>2</sup> of GaAs needed per wafer area. The difference between module area and cell-wafer area is, of course, the concentration that greatly reduces the amounts of expensive semiconductor material needed.

### 6.0 References

1. Mauk, M.G., P.E. Sims, and R.B. Hall, "Feedstock for Crystalline Silicon Solar Cells," Proceedings of the First Conference on Future Generation Photovoltaic Technologies (March 1997).
2. Swanson, R.M., "Straight Talk about Concentrators," Proceedings of the First Conference on Future Generation Photovoltaic Technologies (March 1997).
3. Kurtz, S.R., and D. Friedman, "Recent Developments in Terrestrial Concentrator Photovoltaics," Proceedings of the 14th NREL Photovoltaics Program Review, (November 1996).
4. "The PV Concentrator Alliance Founding Position Paper," PV Concentrator Alliance, for the U.S. Department of Energy: April 1997.
5. Solar Radiation Data Manual for Flat-Plate and Concentrating Collectors, National Renewable Energy Laboratory: April 1994. Report TP-463-5607.
6. Recent Advances in the EPRI High-Concentration Photovoltaic Program, Volume 2, Electric Power Research Institute: February 1992. Report EPRI/TR-100393.

## UTILITY-SCALE PHOTOVOLTAIC CONCENTRATORS

7. Garboushian, V., D. Roubideaux, and S. Yoon, "An Evaluation of Integrated High-Concentration Photovoltaics for Large-Scale Grid-Connected Applications," Proceedings of the Twenty-Fifth IEEE PV Specialist s Conference, Washington, D.C. (May 1996).
8. Ruby, D., "Manufacturing of Silicon Concentrator Solar Cells," Proceedings of the First European Union International Workshop on Crystalline-Silicon Solar Cells (April 1994).
9. Deb, S.K., "Novel Material Architectures for Photovoltaics," Proceedings of the First Conference on Futur e Generation Photovoltaic Technologies (March 1997).
10. U.S. Department of Energy, Photovoltaics, the Power of Choice: DOE National Photovoltaics Program Five-Year Research Plan for 1996-2000, DOE/GO-10096-017, March 1997.
11. Kazmerski, L.L., "Photovoltaics: A Review of Cell and Module Technologies," Renewable and Sustainabl e Energy Review, to be published.
12. Gunn, J.A., and F.J. Dostalek, "EPRI 25-kW High-Concentration Photovoltaic Integrated Array Concept and Associated Economics," Proceedings of the Twenty-Third IEEE PV Specialists Conference, Louisville, KY (May 1993).
13. Jennings, C., A. Reyes, and K. O'Brien, "PVUSA Utility-Scale System Capital and Maintenance Costs, " Proceedings of the First World Conference on Photovoltaic Energy Conversion (December 1994).
14. Maish, A.B., "PV Concentrator Array Installed Costs," Proceedings of the ASME Solar Energy Division Conference (April 1983).
15. Mitchell, K.W., "The Renaissance of Cz Si Photovoltaics," Progress in Photovoltaics, April 1994.

## OVERVIEW OF SOLAR THERMAL TECHNOLOGIES

### Introduction

There are three solar thermal power systems currently being developed by U.S. industry: parabolic troughs, power towers, and dish/engine systems. Because these technologies involve a thermal intermediary, they can be readily hybridized with fossil fuel and in some cases adapted to utilize thermal storage. The primary advantage of hybridization and thermal storage is that the technologies can provide dispatchable power and operate during periods when solar energy is not available. Hybridization and thermal storage can enhance the economic value of the electricity produced and reduce its average cost. This chapter provides an introduction to the more detailed chapters on each of the three technologies, an overview of the technologies, their current status, and a map identifying the U.S. regions with best solar resource.

**Parabolic Trough** systems use parabolic trough-shaped mirrors to focus sunlight on thermally efficient receiver tubes that contain a heat transfer fluid (Figure 1). This fluid is heated to 390 °C (734°F) and pumped through a series of heat exchangers to produce superheated steam which powers a conventional turbine generator to produce electricity. Nine trough systems, built in the mid to late 1980's, are currently generating 354 MW in Southern California. These systems, sized between 14 and 80 MW, are hybridized with up to 25% natural gas in order to provide dispatchable power when solar energy is not available.

Cost projections for trough technology are higher than those for power towers and dish/engine systems due in large part to the lower solar concentration and hence lower temperatures and efficiency. However, with 10 years of operating experience, continued technology improvements, and O&M cost reductions, troughs are the least expensive, most reliable solar technology for near-term applications.

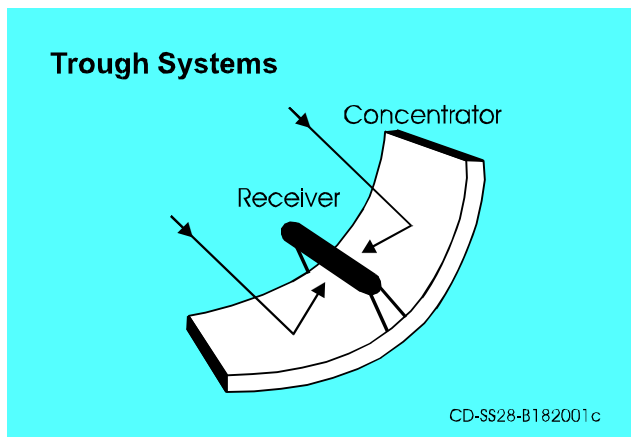

Figure 1. Solar parabolic trough.

**Power Tower** systems use a circular field array of heliostats (large individually-tracking mirrors) to focus sunlight onto a central receiver mounted on top of a tower (Figure 2). The first power tower, Solar One, which was built in Southern California and operated in the mid-1980's, used a water/steam system to generate 10 MW of power. In 1992, a consortium of U.S. utilities banded together to retrofit Solar One to demonstrate a molten-salt receiver and thermal storage system.

The addition of this thermal storage capability makes power towers unique among solar technologies by promising dispatchable power at load factors of up to 65%. In this system, molten-salt is pumped from a "cold" tank at 288°C

## OVERVIEW OF SOLAR THERMAL TECHNOLOGIES

(550°F) and cycled through the receiver where it is heated to 565°C (1,049°F) and returned to a “hot” tank. The hot salt can then be used to generate electricity when needed. Current designs allow storage ranging from 3 to 13 hours.

“Solar Two” first generated power in April 1996, and is scheduled to run for a 3-year test, evaluation, and power production phase to prove the molten-salt technology. The successful completion of Solar Two should facilitate the early commercial deployment of power towers in the 30 to 200 MW range.

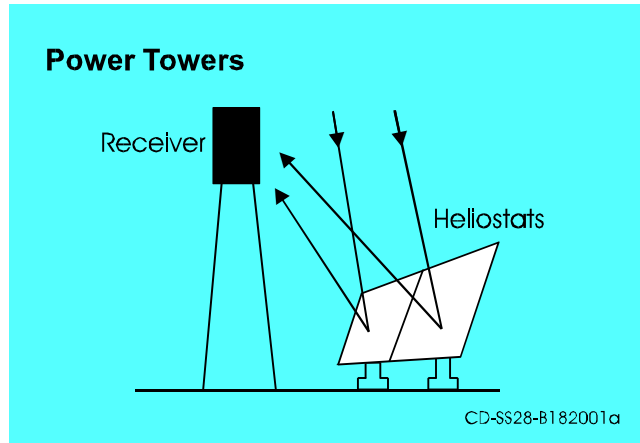

Figure 2. Solar power tower.

**Dish/Engine** systems use an array of parabolic dish-shaped mirrors (stretched membrane or flat glass facets) to focus solar energy onto a receiver located at the focal point of the dish (Figure 3). Fluid in the receiver is heated to 750 °C (1,382°F) and used to generate electricity in a small engine attached to the receiver. Engines currently under consideration include Stirling and Brayton cycle engines. Several prototype dish/engine systems, ranging in size from 7 to 25 kW<sub>e</sub>, have been deployed in various locations in the U.S. and abroad.

High optical efficiency and low startup losses make dish/engine systems the most efficient (29.4% record solar to electricity conversion) of all solar technologies. In addition, the modular design of dish/engine systems make them a good match for both remote power needs in the kilowatt range as well as hybrid end-of-the-line grid-connected utility applications in the megawatt range. If field validation of these systems is successful in 1998 and 1999, commercial sales could commence as early as 2000.

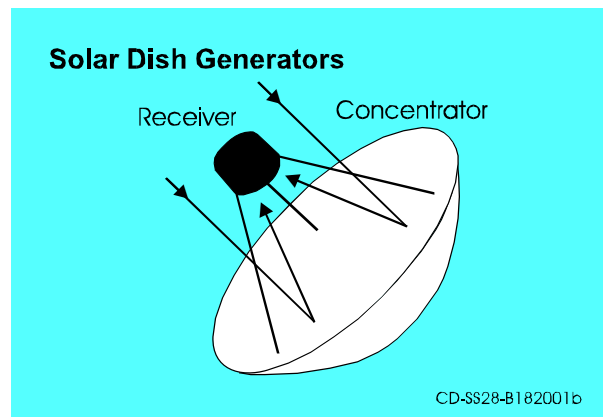

Figure 3. Solar dish/engine system.

## OVERVIEW OF SOLAR THERMAL TECHNOLOGIES

### Technology Comparison

Table 1 below highlights the key features of the three solar technologies. Towers and troughs are best suited for large, grid-connected power projects in the 30-200 MW size, whereas, dish/engine systems are modular and can be used in single dish applications or grouped in dish farms to create larger multi-megawatt projects. Parabolic trough plants are the most mature solar power technology available today and the technology most likely to be used for near-term deployments. Power towers, with low cost and efficient thermal storage, promise to offer dispatchable, high capacity factor, solar-only power plants in the near future. The modular nature of dishes will allow them to be used in smaller, high-value applications.

Towers and dishes offer the opportunity to achieve higher solar-to-electric efficiencies and lower cost than parabolic trough plants, but uncertainty remains as to whether these technologies can achieve the necessary capital cost reductions and availability improvements. Parabolic troughs are currently a proven technology primarily waiting for an opportunity to be developed. Power towers require the operability and maintainability of the molten-salt technology to be demonstrated and the development of low cost heliostats. Dish/engine systems require the development of at least one commercial engine and the development of a low cost concentrator.

Table 1. Characteristics of solar thermal electric power systems.

	Parabolic Trough	Power Tower	Dish/Engine
Size	30-320 MW*	10-200 MW*	5-25 kW*
Operating Temperature (°C/°F)	390/734	565/1,049	750/1,382
Annual Capacity Factor	23-50%*	20-77%*	25%
Peak Efficiency	20%(d)	23%(p)	29.4%(d)
Net Annual Efficiency	11(d')-16%*	7(d')-20%*	12-25%*(p)
Commercial Status	Commercially Available	Scale-up Demonstration	Prototype Demonstration
Technology Development Risk	Low	Medium	High
Storage Available	Limited	Yes	Battery
Hybrid Designs	Yes	Yes	Yes
Cost			
\$/m <sup>2</sup>	630-275*	475-200*	3,100-320*
\$/W	4.0-2.7*	4.4-2.5*	12.6-1.3*
\$/W <sub>p</sub> <sup>†</sup>	4.0-1.3*	2.4-0.9*	12.6-1.1*

\* Values indicate changes over the 1997-2030 time frame.

†  $\$/W_p$  removes the effect of thermal storage (or hybridization for dish/engine). See discussion of thermal storage in the power tower TC and footnotes in Table 4.

(p) = predicted; (d) = demonstrated; (d') = has been demonstrated, out years are predicted values

### Cost Versus Value

Through the use of thermal storage and hybridization, solar thermal electric technologies can provide a firm and dispatchable source of power. Firm implies that the power source has a high reliability and will be able to produce power when the utility needs it. Dispatchability implies that power production can be shifted to the period when it is needed. As a result, firm dispatchable power is of value to a utility because it offsets the utility's need to build and operate new power plants. This means that even though a solar thermal plant might cost more, it can have a higher value.

# OVERVIEW OF SOLAR THERMAL TECHNOLOGIES

## Solar Thermal Power Cost and Development Issues

The cost of electricity from solar thermal power systems will depend on a multitude of factors. These factors, discussed in detail in the specific technology sections, include capital and O&M cost, and system performance. However, it is important to note that the technology cost and the eventual cost of electricity generated will be significantly influenced by factors “external” to the technology itself. As an example, for troughs and power towers, small stand-alone projects will be very expensive. In order to reduce the technology costs to compete with current fossil technologies, it will be necessary to scale-up projects to larger plant sizes and to develop solar power parks where multiple projects are built at the same site in a time phased succession. In addition, since these technologies in essence replace conventional fuel with capital equipment, the cost of capital and taxation issues related to capital intensive technologies will have a strong effect on their competitiveness.

## Solar Resources

Solar resource is one of the most important factors in determining performance of solar thermal systems. The Southwestern United States potentially offers the best development opportunity for solar thermal electric technologies in the world. There is a strong correlation between electric power demand and the solar resource due largely to the air conditioning loads in the region. Figure 4 shows the direct normal insolation for the United States.

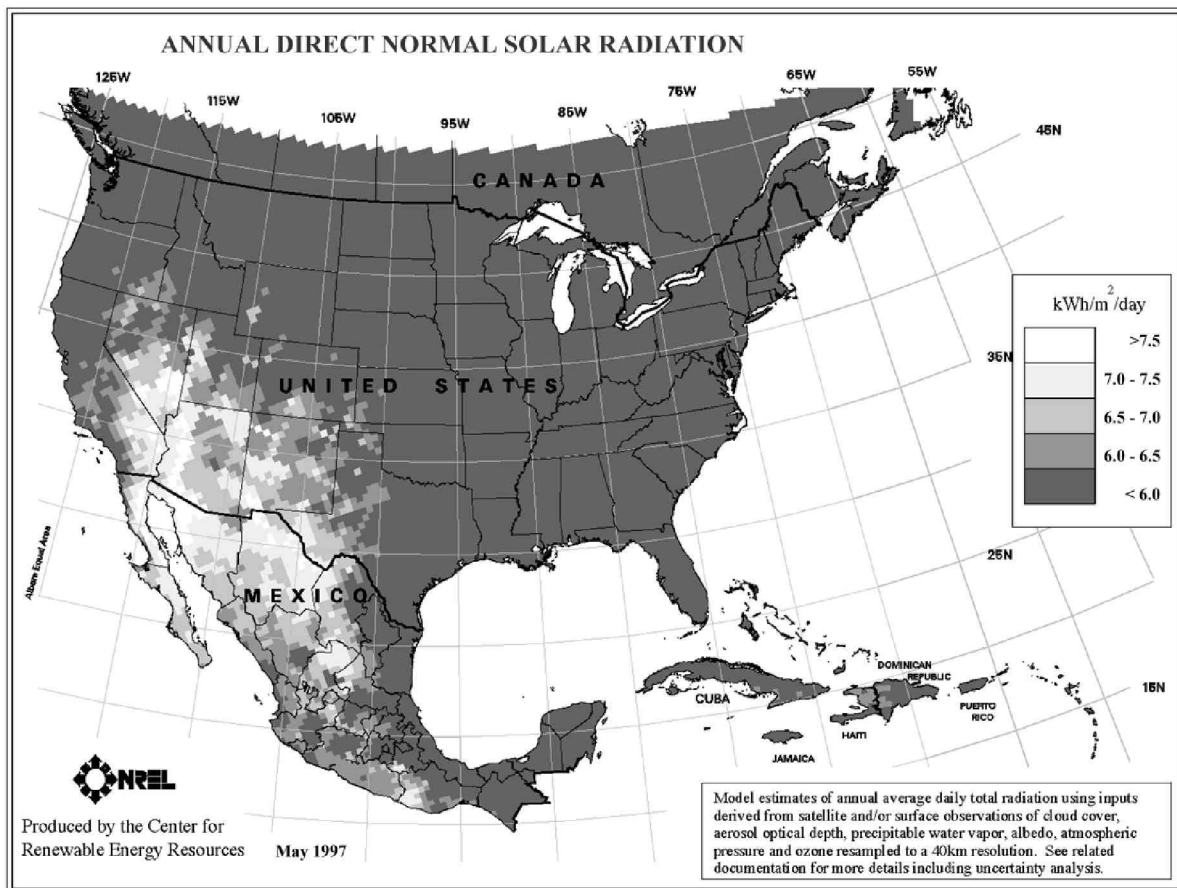

Figure 4. Direct normal insolation resource.

## OVERVIEW OF SOLAR THERMAL TECHNOLOGIES

### Summary

Solar thermal power technologies are in different stages of development. Trough technology is commercially available today, with 354 MW currently operating in the Mojave Desert in California. Power towers are in the demonstration phase, with the 10 MW Solar Two pilot plant located in Barstow, CA., currently undergoing at least two years of testing and power production. Dish/engine technology has been demonstrated. Several system designs are under engineering development, a 25 kW prototype unit is on display in Golden, CO, and five to eight second-generation systems are scheduled for field validation in 1998. Solar thermal power technologies have distinct features that make them attractive energy options in the expanding renewable energy market worldwide. Comprehensive reviews of the solar thermal electric technologies are offered in References 1 and 2.

### References

1. Status Report on Solar Thermal Power Plants, Pilkington Solar International: 1996. Report ISBN 3-9804901-0-6.
2. Holl, R.J., Status of Solar-Thermal Electric Technology, Electric Power Research Institute: December 1989. Report GS- 6573.
3. Mancini, T., G.J. Kolb, and M. Prairie, "Solar Thermal Power", Advances in Solar Energy: An Annual Review of Research and Development, Vol. 11, edited by Karl W. Boer, American Solar Energy Society, Boulder, CO , 1997, ISBN 0-89553-254-9.



# SOLAR POWER TOWER

## 1.0 System Description

Solar power towers generate electric power from sunlight by focusing concentrated solar radiation on a tower-mounted heat exchanger (receiver). The system uses hundreds to thousands of sun-tracking mirrors called heliostats to reflect the incident sunlight onto the receiver. These plants are best suited for utility-scale applications in the 30 to 400 MW<sub>e</sub> range.

In a molten-salt solar power tower, liquid salt at 290°C (554°F) is pumped from a ‘cold’ storage tank through the receiver where it is heated to 565°C (1,049°F) and then on to a ‘hot’ tank for storage. When power is needed from the plant, hot salt is pumped to a steam generating system that produces superheated steam for a conventional Rankine - cycle turbine/generator system. From the steam generator, the salt is returned to the cold tank where it is stored and eventually reheated in the receiver. Figure 1 is a schematic diagram of the primary flow paths in a molten-salt solar power plant. Determining the optimum storage size to meet power-dispatch requirements is an important part of the system design process. Storage tanks can be designed with sufficient capacity to power a turbine at full output for up to 13 hours.

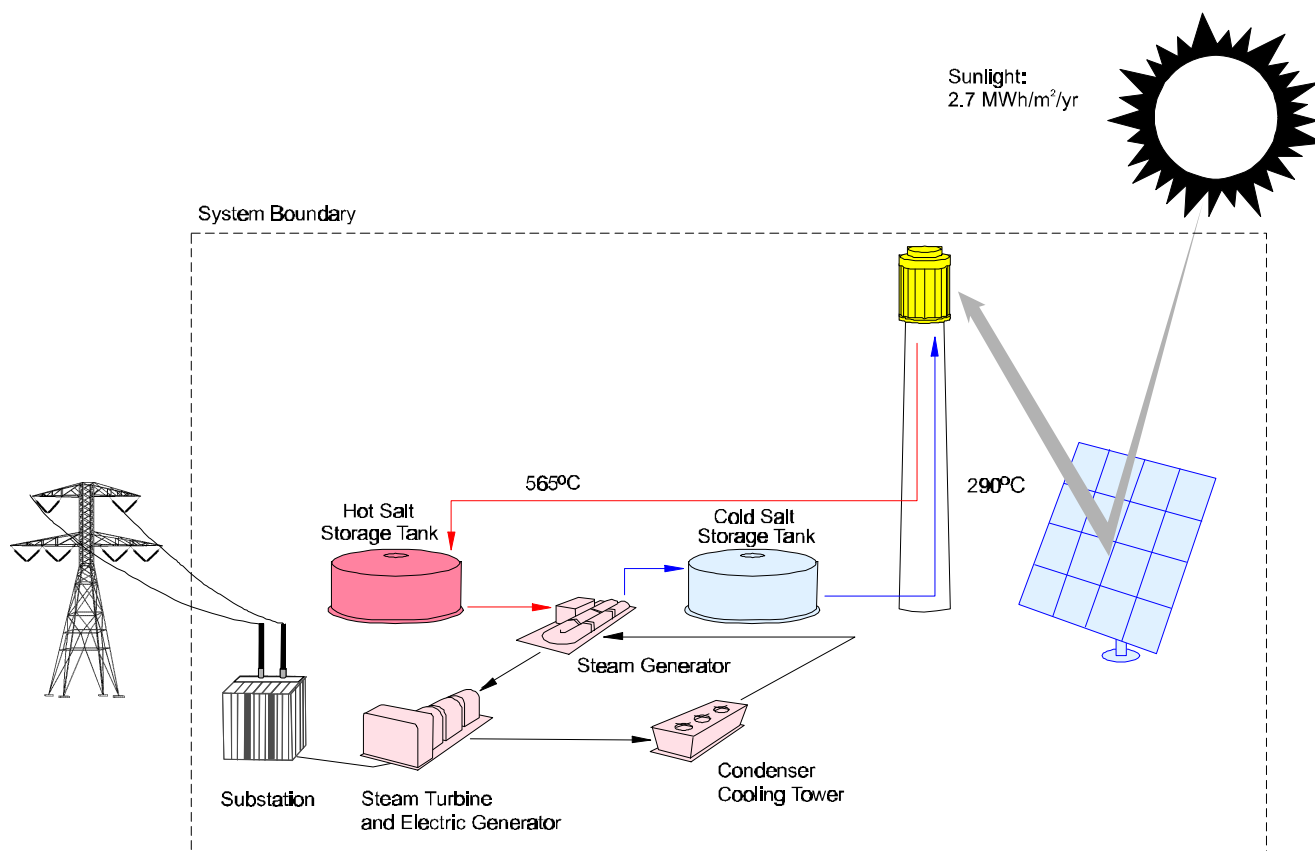

Figure 1. Molten-salt power tower system schematic (Solar Two, baseline configuration).

The heliostat field that surrounds the tower is laid out to optimize the annual performance of the plant. The field and the receiver are also sized depending on the needs of the utility. In a typical installation, solar energy collection occurs at a rate that exceeds the maximum required to provide steam to the turbine. Consequently, the thermal storage system can be *charged* at the same time that the plant is producing power at full capacity. The ratio of the thermal power

## SOLAR POWER TOWER

provided by the collector system (the heliostat field and receiver) to the peak thermal power required by the turbine generator is called the solar multiple. With a solar multiple of approximately 2.7, a molten-salt power tower located in the California Mojave desert can be designed for an annual capacity factor of about 65%. (Based on simulations at Sandia National Laboratories with the SOLERGY [1] computer code.) Consequently, a power tower could potentially operate for 65% of the year without the need for a back-up fuel source. Without energy storage, solar technologies are limited to annual capacity factors near 25%.

The dispatchability of electricity from a molten-salt power tower is illustrated in Figure 2, which shows the load-dispatching capability for a typical day in Southern California. The figure shows solar intensity, energy stored in the hot tank, and electric power output as functions of time of day. In this example, the solar plant begins collecting thermal energy soon after sunrise and stores it in the hot tank, accumulating energy in the tank throughout the day. In response to a peak-load demand on the grid, the turbine is brought on line at 1:00 PM and continues to generate power until 11 PM. Because of the storage, power output from the turbine generator remains constant through fluctuations in solar intensity and until all of the energy stored in the hot tank is depleted. Energy storage and dispatchability are very important for the success of solar power tower technology, and molten salt is believed to be the key to cost-effective energy storage.

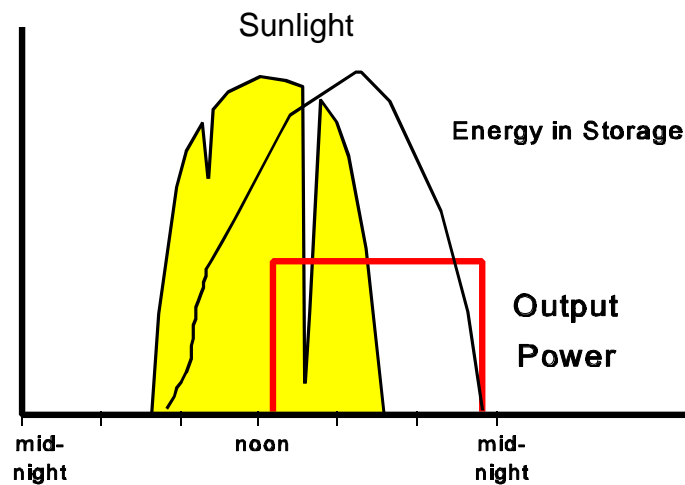

Figure 2. Dispatchability of molten-salt power towers.

Power towers must be large to be economical. Power tower plants are not modular and can not be built in the smaller sizes of dish/Stirling or trough-electric plants and be economically competitive, but they do use a conventional power block and can easily dispatch power when storage is available. In the United States, the Southwest is ideal for power towers because of its abundant high levels of insolation and relatively low land costs. Similar locations in northern Africa, Mexico, South America, the Middle East, and India are also well-suited for power towers.

### History

Although power towers are commercially less mature than parabolic trough systems, a number of component and experimental systems have been field tested around the world in the last 15 years, demonstrating the engineering feasibility and economic potential of the technology. Since the early 1980s, power towers have been fielded in Russia,

## SOLAR POWER TOWER

Italy, Spain, Japan, France, and the United States [2]. In Table 1, these experiments are listed along with some of their more important characteristics. These experimental facilities were built to prove that solar power towers can produce electricity and to prove and improve on the individual system components. Solar Two, which is currently going through its startup phase, will generate (in addition to electric power) information on the design, performance, operation and maintenance of molten-salt power towers. The objective of Solar Two is to mitigate the perceived technological and financial risks associated with the first commercial plants and to prove the molten-salt thermal storage technology.

Table 1. Experimental power towers.

Project	Country	Power Output (MWe)	Heat Transfer Fluid	Storage Medium	Operation Began
SSPS	Spain	0.5	Liquid Sodium	Sodium	1981
EURELIOS	Italy	1	Steam	Nitrate Salt/Water	1981
SUNSHINE	Japan	1	Steam	Nitrate Salt/Water	1981
Solar One	USA	10	Steam	Oil/Rock	1982
CESA-1	Spain	1	Steam	Nitrate Salt	1983
MSEE/Cat B	USA	1	Molten Nitrate	Nitrate Salt	1984
THEMIS	France	2.5	Hi-Tec Salt	Hi-Tec Salt	1984
SPP-5	Russia	5	Steam	Water/ Steam	1986
TSA	Spain	1	Air	Ceramic	1993
Solar Two	USA	10	Molten Nitrate Salt	Nitrate Salt	1996

In early power towers, the thermal energy collected at the receiver was used to generate steam directly to drive a turbine generator. Although these systems were simple, they had a number of disadvantages that will be described in the discussions that follow.

### Solar One

Solar One, which operated from 1982 to 1988, was the world's largest power tower plant. It proved that large-scale power production with power towers was feasible. In that plant, water was converted to steam in the receiver and used directly to power a conventional Rankine-cycle steam turbine. The heliostat field consisted of 1818 heliostats of 39.3 m<sup>2</sup> reflective area each. The project met most of its technical objectives by demonstrating (1) the feasibility of generating power with a power tower, (2) the ability to generate 10 MWe for eight hours a day at summer solstice and four hours a day near winter solstice. During its final year of operation, Solar One's availability during hours of sunshine was 96% and its annual efficiency was about 7%. (Annual efficiency was relatively low because of the plant's small size and the inclusion of non-optimized subsystems.)

The Solar One thermal storage system stored heat from solar-produced steam in a tank filled with rocks and sand using oil as the heat-transfer fluid. The system extended the plant's power-generation capability into the night and provided heat for generating low-grade steam for keeping parts of the plant warm during off-hours and for morning startup. Unfortunately, the storage system was complex and thermodynamically inefficient. While Solar One successfully demonstrated power tower technology, it also revealed the disadvantages of a water/steam system, such as the intermittent operation of the turbine due to cloud transience and lack of effective thermal storage.

During the operation of Solar One, research began on the more advanced molten-salt power tower design described previously. This development culminated in the Solar Two project.

## SOLAR POWER TOWER

### Solar Two

To encourage the development of molten-salt power towers, a consortium of utilities led by Southern California Edison joined with the U.S. Department of Energy to redesign the Solar One plant to include a molten-salt heat-transfer system. The goals of the redesigned plant, called Solar Two, are to validate nitrate salt technology, to reduce the technical and economic risk of power towers, and to stimulate the commercialization of power tower technology. Solar Two has produced 10 MW of electricity with enough thermal storage to continue to operate the turbine at full capacity for three hours after the sun has set. Long-term reliability is next to be proven.

The conversion of Solar One to Solar Two required a new molten-salt heat transfer system (including the receiver, thermal storage, piping, and a steam generator) and a new control system. The Solar One heliostat field, the tower, and the turbine/generator required only minimal modifications. Solar Two was first attached to a utility grid in early 1996 and is scheduled to complete its startup phase in late 1997.

The Solar Two receiver was designed and built by Boeing's Rocketdyne division. It comprises a series of panels (each made of 32 thin-walled, stainless steel tubes) through which the molten salt flows in a serpentine path. The panels form a cylindrical shell surrounding piping, structural supports, and control equipment. The external surfaces of the tubes are coated with a black Pyromark™ paint that is robust, resistant to high temperatures and thermal cycling, and absorbs 95% of the incident sunlight. The receiver design has been optimized to absorb a maximum amount of solar energy while reducing the heat losses due to convection and radiation. The design, which includes laser-welding, sophisticated tube-nozzle-header connections, a tube clip design that facilitates tube expansion and contraction, and non-contact flux measurement devices, allows the receiver to rapidly change temperature without being damaged. For example, during a cloud passage, the receiver can safely change from 290 to 570°C (554 to 1,058°F) in less than one minute.

The salt storage medium is a mixture of 60 percent sodium nitrate and 40 percent potassium nitrate. It melts at 220°C (428°F) and is maintained in a molten state (290°C/554°F) in the 'cold' storage tank. Molten salt can be difficult to handle because it has a low viscosity (similar to water) and it wets metal surfaces extremely well. Consequently, it can be difficult to contain and transport. An important consideration in successfully implementing this technology is the identification of pumps, valves, valve packing, and gasket materials that will work with molten salt. Accordingly, Solar Two is designed with a minimum number of gasketed flanges and most instrument transducers, valves, and fittings are welded in place.

The energy storage system for Solar Two consists of two 875,000 liter storage tanks which were fabricated on-site by Pitt-Des Moines. The tanks are externally insulated and constructed of stainless steel and carbon steel for the hot and cold tanks, respectively. Thermal capacity of the system is 110 MWh. A natural convection cooling system is used in the foundation of each tank to minimize overheating and excessive dehydration of the underlying soil.

All pipes, valves, and vessels for hot salt were constructed from stainless steel because of its corrosion resistance in the molten-salt environment. The cold-salt system is made from mild carbon steel. The steam generator system (SGS) heat exchangers, which were constructed by ABB Lummus, consist of a shell-and-tube superheater, a kettle boiler, and a shell-and-tube preheater. Stainless steel cantilever pumps transport salt from the hot-tank-pump sump through the SGS to the cold tank. Salt in the cold tank is pumped with multi-stage centrifugal pumps up the tower to the receiver.

Solar Two is expected to begin routine daily power production in late 1997. Initial data collected at the plant show that the molten-salt receiver and thermal storage tanks should perform as predicted during design. For example, data collected on March 26, 1997, revealed that the receiver absorbed 39.8 MW<sub>e</sub>, which is 93% of the design value. Considering the fact that the heliostat field had significant alignment problems at the time of the measurement, the receiver is expected to reach 100% of the design after realignment. This was reaffirmed by efficiency tests conducted

## SOLAR POWER TOWER

in October 1997 which indicated an 87% value; this is nearly identical to the design prediction. The hot tank within the thermal storage system has also exhibited excellent thermal characteristics. Figure 3 depicts a month-long cool down of the hot storage tank when it was filled with molten salt. It can be seen that the tank cools very slowly (about 75°C/167°F over one month) and the measured thermal losses are within about 10% of the design prediction.

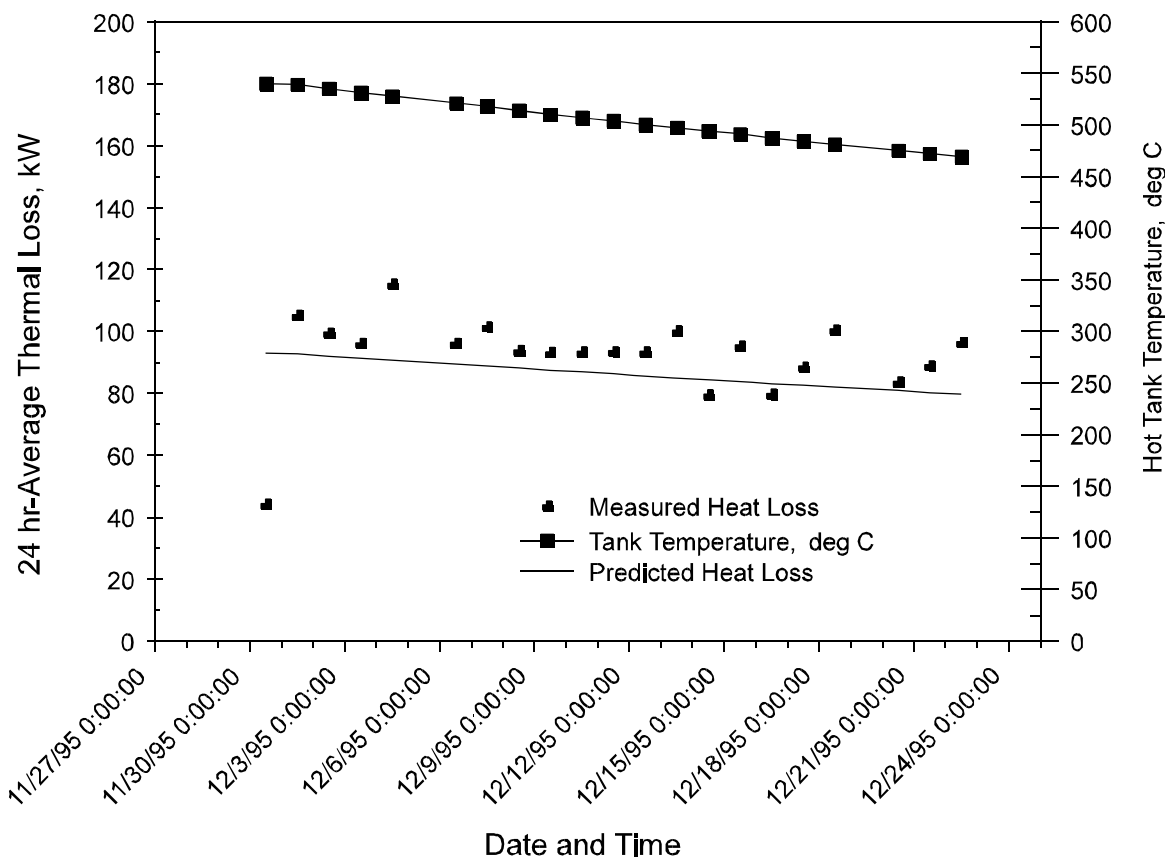

Figure 3. Cool down of hot storage tank at Solar Two.

It is important to note that at 10 MW, Solar Two is too small to be economically viable. Operation and maintenance (O&M) costs for a small solar only power tower are too high. This can be demonstrated by examining Table 3 (to be presented later). O&M costs become reasonable at 30 MW or greater system sizes. This has also been observed at the operating SEGS trough plants.

# SOLAR POWER TOWER

## 2.0 System Application, Benefits, and Impacts

### Overview

To date, the largest power towers ever built are the 10 MW Solar One and Solar Two plants. Assuming success of the Solar Two project, the next plants could be scaled-up to between 30 and 100 MW in size for utility grid connected applications in the Southwestern United States and/or international power markets. New peaking and intermediate power sources are needed today in many areas of the developing world. India, Egypt, and South Africa are locations that appear to be ideally suited for power tower development. As the technology matures, plants with up to a 400 MW rating appear feasible. As non-polluting energy sources become more favored, molten-salt power towers will have a high value because the thermal energy storage allows the plant to be dispatchable. Consequently, the value of power is worth more because a power tower plant can deliver energy during peak load times when it is more valuable. Energy storage also allows power tower plants to be designed and built with a range of annual capacity factors (20 to 65%). Combining high capacity factors and the fact that energy storage will allow power to be brought onto the grid in a controlled manner (i.e., by reducing electrical transients thus increasing the stability of the overall utility grid), total market penetration should be much higher than an intermittent solar technology without storage.

One possible concern with the technology is the relatively high amount of land and water usage. This may become an important issue from a practical and environmental viewpoint since these plants are typically deployed within desert areas that often lack water and have fragile landscapes. Water usage at power towers is comparable to other Rankine cycle power technologies of similar size and annual performance. Land usage, although significant, is typically much less than that required for hydro [3] and is generally less than that required for fossil (e.g., oil, coal, natural gas), when the mining and exploration of land are included.

### Initial System Application - Hybrid Plants

To reduce the financial risk associated with the deployment of a new power plant technology and to lower the cost of delivering solar power, initial commercial-scale (>30 MW<sub>e</sub>) power towers will likely be hybridized with conventional fossil-fired plants. Many hybridization options are possible with natural gas combined-cycle and coal-fired or oil-fired Rankine plants. One opportunity for hybrid integration with a combined cycle is depicted in Figure 4.

In a hybrid plant, the solar energy can be used to reduce fossil fuel usage and/or boost the power output to the steam turbine. Typical daily power output from the hypothetical “power boost” hybrid power plant is depicted in Figure 5. From the figure it can be seen that in a power boost hybrid plant we have, in effect, “piggybacked” a solar-only plant on top of a base-loaded fossil-fueled plant.

In the power boost hybrid plant, additional electricity is produced by oversizing the steam turbine, contained within a coal-fired Rankine plant or the bottoming portion of a combined-cycle plant (Figure 4), so that it can operate on both full fossil and solar energy when solar is available. Studies of this concept have typically oversized the steam turbine from 25% to 50% beyond what the turbine can produce in the fossil-only mode. Oversizing beyond this range is not recommended because the thermal-to-electric conversion efficiency will degrade at the part loads associated with operating in the fuel-only mode.

## SOLAR POWER TOWER

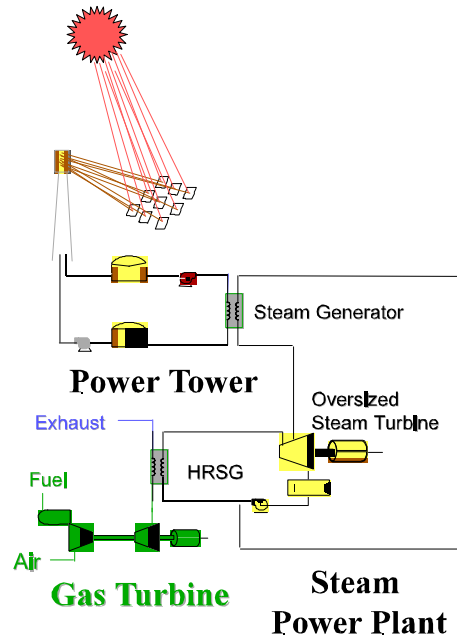

Figure 4. Power tower hybridized with combined cycle plant [4]. Power is produced in the gas turbine (fossil only) and from the steam turbine (fossil and solar). Steam from the solar steam generator is blended with fossil steam from the heat recovery steam generator (HRSG) before entering a steam turbine.

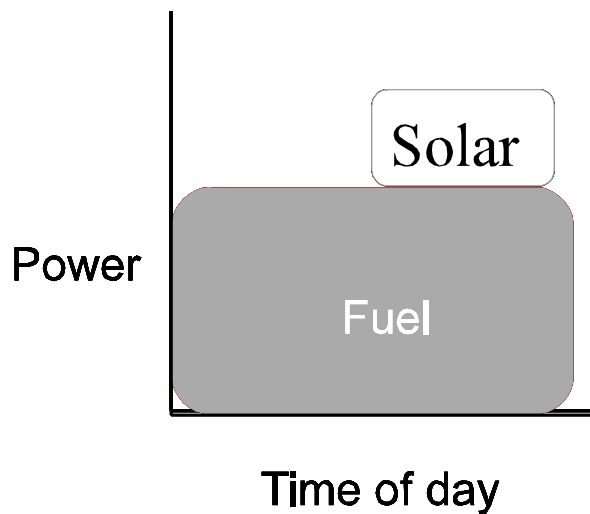

Figure 5. A hypothetical power profile from a hybrid plant. In this case, thermal storage is used to dispatch the solar electricity late in the day to meet an evening peak that lasts well into the night ( a pattern that is common in the U.S. Southwest and in many developing nations).

## SOLAR POWER TOWER

When hybridizing a solar power tower with a base-load fossil-fired plant, solar contributes about 25% of the peak power output from the plant and between 10 and 25% of the annual electricity. (The higher annual solar fraction can be achieved with 13 hours of thermal storage and the lower solar fraction with just a few hours of storage.) Designing plants with a relatively modest solar fraction reduces financial risk because the majority of the electricity is derived from proven fossil technology and steady payment for power sales is assured.

### System Benefits -Energy Storage

The availability of an inexpensive and efficient energy storage system may give power towers a competitive advantage. Table 2 provides a comparison of the predicted cost, performance, and lifetime of solar-energy storage technologies for hypothetical 200 MW plants [5,6].

Table 2. Comparison of solar-energy storage systems.

	Installed cost of energy storage for a 200 MW plant (\$/kWhr.)	Lifetime of storage system (years)	Round-trip storage efficiency (%)	Maximum operating temperature (°C/°F)
Molten-Salt Power Tower	30	30	99	567/1,053
Synthetic-Oil Parabolic Trough	200	30	95	390/734
Battery Storage Grid Connected	500 to 800	5 to 10	76	N/A

Thermal-energy storage in the power tower allows electricity to be dispatched to the grid when demand for power is the highest, thus increasing the monetary value of the electricity. Much like hydro plants, power towers with salt storage are considered to be a dispatchable rather than an intermittent renewable energy power plant. For example, Southern California Edison company gives a power plant a capacity payment if it is able to meet their dispatchability requirement: an 80% capacity factor from noon to 6 PM, Monday through Friday, from June through September. Detailed studies [7] have indicated that a solar-only plant with 4 hours of thermal storage can meet this dispatchability requirement and thus qualify for a full capacity payment. While the future deregulated market place may recognize this value differently, energy delivered during peak periods will certainly be more valuable.

Besides making the power dispatchable, thermal storage also gives the power-plant designer freedom to develop power plants with a wide range of capacity factors to meet the needs of the utility grid. By varying the size of the solar field, solar receiver, and size of the thermal storage, plants can be designed with annual capacity factors ranging between 20 and 65% (see Figure 6).

Economic studies have shown that levelized energy costs are reduced by adding more storage up to a limit of about 13 hours (~65% capacity factor) [8]. While it is true that storage increases the cost of the plant, it is also true that plants with higher capacity factors have better economic utilization of the turbine, and other balance of plant equipment. Since salt storage is inexpensive, reductions in LEC due to increased utilization of the turbine more than compensate for the increased cost due to the addition of storage.



## SOLAR POWER TOWER

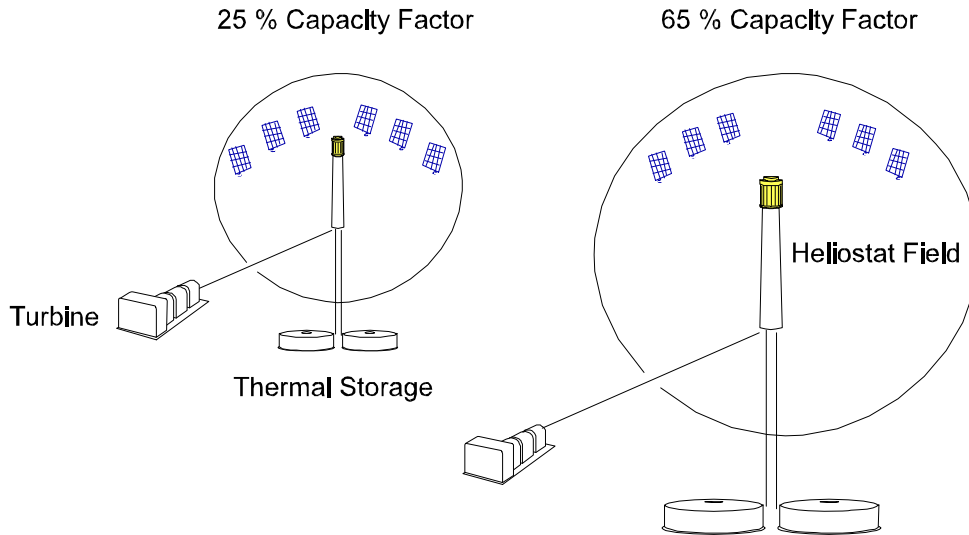

Figure 6. In a solar power tower, plant design can be altered to achieve different capacity factors. To increase capacity factor for a given turbine size, the designer would (1) increase the number of heliostats, (2) enlarge the thermal storage tanks, (3) raise the tower, and (4) increase the receiver dimensions.

### Environmental Impacts

No hazardous gaseous or liquid emissions are released during operation of the solar power tower plant. If a salt spill occurs, the salt will freeze before significant contamination of the soil occurs. Salt is picked up with a shovel and can be recycled if necessary. If the power tower is hybridized with a conventional fossil plant, emissions will be released from the non-solar portion of the plant.

### 3.0 Technology Assumptions and Issues

Assuming success at Solar Two, power tower technology will be on the verge of technology readiness for commercial applications. However, progress related to scale-up and R&D for specific subsystems is still needed to reduce costs and to increase reliability to the point where the technology becomes an attractive financial investment. Promising work is ongoing in the following areas:

#### First Commercial System

Ideally, to be economically competitive with conventional fossil technology, a power tower should be at least 10 times larger than Solar Two [4]. It may be possible to construct this plant directly following Solar Two, but the risk perceived by the technical and financial communities may require that a plant of intermediate size (30-50 MW) be constructed first. The World Bank will consider requests for funding power tower projects following a successful two-year operation of Solar Two. However, countries interested in the technology have indicated they may need to see a utility-scale plant operating in the U.S. before they will include power towers in their energy portfolio. Since the electricity cost of a stand-alone 30 MW solar-only plant will be significantly higher than the fossil competition, innovative

## SOLAR POWER TOWER

financing options or subsidies need to be developed to support this mid-size project. Fossil hybridization designs are also being explored as another possible way of aiding market entry (see hybrid discussion in Section 2). The benefits of the reduced size plant include reduced scale-up risk and reduced capital investment.

### Heliostats

Relatively few heliostats have been manufactured to date, and their cost is high ( $> \$250/\text{m}^2$ ). As the demand for solar power increases, heliostat mass production methods will be developed that will significantly reduce their cost (actual evidence of this has been seen in the parabolic trough industry). Research is currently being conducted under the Solar Manufacturing Technology (SolMaT) Initiative to develop low-cost manufacturing techniques for early commercial low volume builds. Prices are a strong function of annual production rate, as shown in Figure 7. They were estimated by U.S. heliostat manufacturers for rates  $\leq 2,500/\text{yr}$  [9-11]. The price for high annual production (50,000/yr) is a rough estimate. It was obtained by assuming that the price of the entire heliostat scaled with the price of the drive system. Prices for heliostat drives at production levels from 1 to 50,000 units per year were provided by a U.S. drive manufacturer [12,13]. (50,000 units corresponds to 1 GW of additional capacity per year.)

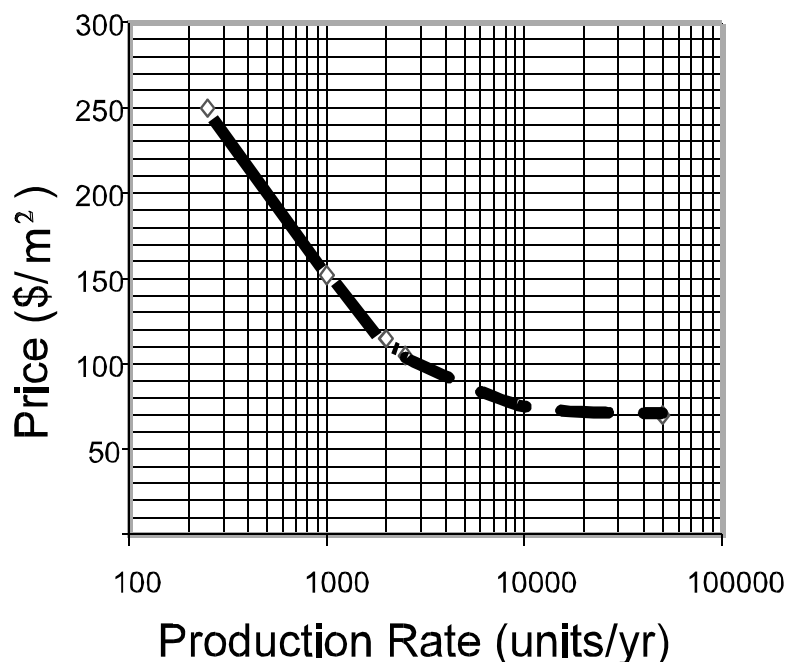

Figure 7. Heliostat price as a function of annual production volume. These prices apply to a heliostat with a surface area of  $150 \text{ m}^2$  and similar in design to those tested at Sandia National Laboratories.

Since the heliostat field represents the largest single capital investment in a power tower plant, advancements in technology are needed to improve the ability to manufacture, reduce costs, and increase the service life of heliostats. In particular, a lower cost azimuth drive system is needed (i.e., to rotate the heliostat around an axis that is perpendicular to the ground).

## SOLAR POWER TOWER

### Receiver

Smaller, simpler receivers are needed to improve efficiency and reduce maintenance. Advanced receiver development is currently underway, under the SolMaT Initiative, includes consideration of new steel alloys for the receiver tubes and ease of manufacture for the entire receiver subsystem. Panels of these new receiver designs are being tested at Solar Two.

### Molten Salt

Molten nitrate salt, though an excellent thermal storage medium, can be a troublesome fluid to deal with because of its relatively high freezing point (220°C/428°F). To keep the salt molten, a fairly complex heat trace system must be employed. (Heat tracing is composed of electric wires attached to the outside surface of pipes. Pipes are kept warm by way of resistance heating.) Problems were experienced during the startup of Solar Two due to the improper installation of the heat trace. Though this problem has been addressed and corrected, research is needed to reduce the reliance on heat tracing in the plant. This could be accomplished by one or more of the following options: (1) develop a salt “anti-freeze” to lower the freezing point, (2) identify and/or develop components that can be “cold started” without preapplication of the heat trace, or (3) develop thermal management practices that are less reliant on heat trace. Within the Solar Two project, the third option will be explored. If it is unsuccessful, the other two options should be pursued. Also, valves can be troublesome in molten-salt service. Special packings must be used, oftentimes with extended bonnets, and leaks are not uncommon. Furthermore, freezing in the valve or packing can prevent it from operating correctly. While today’s valve technology is adequate for molten-salt power towers, design improvements and standardization would reduce risk and ultimately reduce O&M costs.

### Steam Generator

The steam generator design selected for the Solar Two project is completely different than the prototype tested at Sandia Laboratories during the technology development activity of the 1980’s. The recirculating-drum-type system tested at Sandia performed well. However, at Solar Two, a kettle-boiler design was selected in an attempt to reduce cost. Significant problems have been encountered with this new system during the startup phase at Solar Two, requiring a redesign in many areas. Depending on the success of implementing the design changes, it may be appropriate to re-evaluate the optimum steam generator design before proceeding to the first commercial plant.

## 4.0 Performance and Cost

Table 3 summarizes the performance and cost indicators for the solar power tower system being characterized in this report.

### 4.1 Evolution Overview

1997 Technology: The 1997 baseline technology is the Solar Two project with a 43 MW<sub>t</sub> molten nitrate salt central receiver with three hours of thermal storage and 81,000 m<sup>2</sup> of heliostats. The solar input is converted in the existing 10 MW net Rankine steam cycle power plant. The plant is described in detail in Section 1.0 and is expected to have a 20% annual capacity factor following its start-up period.

Table 3. Performance and cost indicators.

INDICATOR NAME	UNITS	Solar Two Prototype 1997		Small Hybrid Booster 2000		Large Hybrid Booster 2005		Solar Only 2010		Advanced Solar Only 2020		Advanced Solar Only 2030	
			+/-%		+/-%		+/-%		+/-%		+/-%		+/-%
Plant Size	MW	10		30		100		200		200		200	
Receiver Thermal Rating	MW <sub>t</sub>	43		145		470		1,400		1,400		1,400	
Heliostat Size	m <sup>2</sup>	40		95		150		150		150		150	
Solar Field Area	m <sup>2</sup>	81,000		275,000		883,000		2,477,000		2,477,000		2,477,000	
Thermal Storage	Hours	3		7		6		13		13		13	
	MWh <sub>t</sub>	114		550		1,600		6,760		6,760		6,760	
<b>Performance</b>													
Capacity Factor	%	20		43		44		65		77		77	
Solar Fraction		1.00		0.22		0.22		1.00		1.00		1.00	
Direct Normal Insolation	kWh/m <sup>2</sup> /yr	2,700		2,700		2,700		2,700		2,700		2,700	
Annual Solar to Elec. Eff.	%	8.5	+5/-20*	15.0	+5/-20	16.2	+5/-20	17.0	+5/-20	20.0	+5/-20	20.0	+5/-20
Annual Energy Production	GWh/yr	17.5		113.0		385.4		1,138.8		1,349.0		1,349.0	
<b>Capital Cost</b>													
Structures & Improvements	\$/kW <sub>nameplate</sub>	†		116	15	60	15	50	15	50	15	50	15
Heliostat System		†		1,666	25	870	25	930	25	865	25	865	25
Tower/Receiver System				600	25	260	25	250	25	250	25	250	25
Thermal Storage System				370	15	240	15	300	15	300	15	300	15
Steam Gen System				276	15	177	15	85	15	85	15	85	15
EPGS/Balance of Plant				417	15	270	15	400	15	400	15	400	15
Master Control System				33	15	10	15	15	15	15	15	15	15
Directs SubTotal (A)				3,429		1,820		2,030		1,965		1,965	
Indirect Engineering/Other	A * 0.1			343		182		203		197		197	
SubTotal (B)				3,772		2,002		2,233		2,162		2,162	
Project/Process Contingency	B * 0.15			566		300		335		325		325	
Total Plant Cost <sup>‡</sup>				4,338		2,302		2,568		2,487		2,487	
Land (@ \$4,942/hectare)				27		27		37		37		37	
Total Capital Requirements	\$/kW <sub>nameplate</sub> \$/kW <sub>peak</sub> <sup>#</sup> \$/m <sup>2</sup>			4,365 2,425 476		2,329 1,294 264		2,605 965 210		2,523 934 204		2,523 934 204	
<b>Operation and Maintenance Cost</b>													
Fixed Labor & Materials	\$/kW-yr												
Total O&M Costs		300		67	25	23	25	30	25	25	25	25	25

Notes:

1. The columns for "+/-%" refer to the uncertainty associated with a given estimate.

2. The construction period is assumed to be 2 years.

\* Design specification for Solar Two. This efficiency is predicted for a mature operating year.

† Cost of these items at Solar Two are not characteristic of a commercial plant and have, therefore, not been listed.

‡ Total plant cost for Solar Two are the actuals incurred to convert the plant from Solar One to Solar Two. The indirect factors listed do not apply to Solar Two.

# To convert to peak values, the effect of thermal storage must be removed. A first-order estimate can be obtained by dividing installed costs by the solar multiple (i.e.,  $SM = \{\text{peak collected solar thermal power}\} \div \{\text{power block thermal power}\}$ ). For example, as discussed in the text, in 2010 the peak receiver absorbed power is 1400 MW<sub>t</sub>. If this is attached to a 220 MW<sub>e</sub> turbine (gross) with a gross efficiency of 42%, thermal demand of the turbine is 520 MW<sub>t</sub>. Thus, SM is 2.7 (i.e., 1400/520) and peak installed cost is  $2605/2.7 = \$965/\text{kW}_{\text{peak}}$ . Solar multiples for years 1997, 2000, and 2005 are 1.2, 1.8, and 1.8, respectively.

## SOLAR POWER TOWER

2000 Technology: The first commercial scale power tower project following the Solar Two project is assumed to be a 145 MW<sub>t</sub> molten nitrate salt central receiver with seven hours of thermal storage and 275,000 m<sup>2</sup> of heliostats. The solar plant may be integrated with either a 30 MW<sub>e</sub> solar-only Rankine cycle plant or with a combined cycle hybrid system like the power booster system described in Section 2.0. A hybrid plant with a 30 MW<sub>e</sub> solar-power-boost, and a 43% annual capacity factor from solar input, is assumed in the case study presented here.

2005 Technology: The system is scaled-up to the original Utility Study [14] size: a 470 MW<sub>t</sub> receiver and 883,000 m<sup>2</sup> heliostat field. Again, the solar plant could be integrated into a 100 MW<sub>e</sub> solar-only Rankine power plant or a hybrid combined cycle power-boost system. A hybrid plant with a 100 MW<sub>e</sub> solar-power-boost, and a 44% annual capacity factor from solar input, is assumed in the case study presented here.

2010 Technology: In 2010, solar-only nitrate-salt power tower plants are assumed to be competitive. The receiver is scaled up to 1,400 MW<sub>t</sub> with thirteen hours of thermal storage and 2,477,000 m<sup>2</sup> of heliostats. The solar plant is attached to a 200 MW Rankine cycle steam turbine and would achieve an annual capacity factor of about 65%.

2020 Technology: The 2020 technology continues to be a 200 MW Rankine solar-only nitrate-salt power plant. Technology development, manufacturing advances, and increased production volumes are assumed to reduce solar plant cost to mature cost targets. Minor technology advances are assumed to continue to fine-tune overall plant performance.

### 4.2 Performance and Cost Discussion

All annual energy estimates presented in Table 3 are based on simulations with the SOLERGY computer code [1]. The inputs to the SOLERGY computer code (mirror reflectance, receiver efficiency, startup times, parasitic power, plant availability, etc.) are based on measured data taken from the 10 MW<sub>e</sub> Solar One and the small (~1 MW<sub>e</sub>) molten-salt receiver system test conducted in the late 1980's [15,16]. The SOLERGY code itself has been validated with a full year of operation at Solar One [17]. However, no overall annual energy data is available from an operating molten-salt power tower. Collection of this data is one of the main goals of the Solar Two demonstration project.

The costs presented in Table 3 for Solar Two are the actuals incurred for the project as reported by Southern California Edison. Capital and operation and maintenance (O&M) cost estimates for 2000 and beyond are consistent with estimates contained in the U.S. Utility Study [14] and the International Energy Agency studies [16]. These studies have been used as a basis to estimate costs for hybrid options and plants with different capacity factors [4]. In addition, O&M costs for power-tower plants with sizes  $\leq 100$  MW<sub>e</sub> have been compared with actuals incurred at the operating 10 to 80 MW<sub>e</sub> solar-trough plants in California with similar sizes to insure consistency. Because of the many similarities between trough and tower technology, a first-order assumption that O&M costs at trough and tower plants are similar has been made.

1997 Technology: During 1997, the plant was completing its startup phase. Solar Two is a sub-commercial-scale plant that is designed to demonstrate the essential elements of the technology. To save capital costs, the plant was sized to have a 20% capacity factor and three hours of thermal storage.

## SOLAR POWER TOWER

The solar-to-electric annual efficiency at Solar Two will be significantly lower than initial commercial-scale plants (8.5% vs. 15% in Table 3) because:

- Unlike the commercial plant, Solar Two does not use a reheat turbine cycle. Consequently, gross Rankine-cycle efficiency will be revised from 42% to 33%;
- Some of the Rankine-cycle equipment is old and other sections of the plant do not employ the equipment redundancy that is expected in the commercial plant. Plant availability is thus expected to be lowered from 91% to 88%;
- The Solar Two heliostat field is not state-of-the-art. The heliostats being used employ an old control strategy and the mirrors have experienced degradation due to corrosion. Also, the reflectance of these older mirrors is below today's standard (89% vs. 94%). Reflectance, corrosion, and controls are not problems with current heliostat technology. In addition, the 108 new heliostats added to the field, though inexpensive, are too large for the receiver that is installed. Consequently, the reflected beams from these heliostats are too large and a portion of the beams do not intercept the receiver target. Combining all these effects, a field performance degradation factor of about 0.9 relative to the commercial plant is expected; and
- Since Solar Two is only 10 MW with a 20% capacity factor, parasitic electricity use will be a much greater fraction of the total gross generation than for a commercial plant with a much higher capacity factor (e.g. parasitics consumed when the plant is offline will be a much greater fraction of the total when the plant has a 20% rather than a 60% capacity factor.) Parasitic energy use at Solar Two is expected to be about 25% of the total gross generation; for a commercial plant, parasitics are predicted to be about 10%.

Combining the factors discussed above, the simple equation below shows how the 15% annual efficiency for the commercial plant is equivalent to about 8.5% at Solar Two.

$$8.5\% = 15\% * (0.33/0.42) * (0.88/0.91) * (0.9) * (0.75/0.9)$$

The 8.5% efficiency is expected to be achieved at Solar Two during its last year of operation after startup problems with the new technology have been solved.

2000 Technology: Following successful operation of Solar Two, the first commercial scale power tower is assumed to be built in the Southwestern U.S. or within a developing nation. At the present time, the Solar Two business consortium is comfortable with scaling up the Solar Two receiver to 145 MW<sub>t</sub> (3.3 times larger than Solar Two [18]). This larger receiver will be combined with a state-of-the-art glass heliostat field ( $\geq 95$  m<sup>2</sup> each) [19], a next-generation molten-salt steam generator design (based on lessons learned at Solar Two), a high-efficiency steam turbine cycle, and will employ modern balance of plant equipment that will improve plant availability. As pointed out in the previous paragraph, these improvements are expected to increase annual efficiency from 8.5 to 15%.

To reduce the financial risk associated with the deployment of this first commercial-scale plant and to lower the cost of delivering solar power, the plant will likely be hybridized with a base-loaded fossil-fired plant. If the solar plant is interfaced with a combined cycle plant, the system layout could be similar to that depicted in Figure 4. Hybridization significantly reduces the cost of producing solar power relative to a solar-only design for the following reasons:

## SOLAR POWER TOWER

- Capital costs for the solar turbine are reduced because only an increment to the base-load fossil turbine must be purchased;
- O&M costs are reduced because only an increment beyond the base-load O&M staff and material s must be used to maintain the solar-specific part of the plant; and,
- The solar plant produces more electricity because the turbine is hot all the time and daily startup losses incurred in a solar-only plant are avoided.

A 145 MW<sub>t</sub> receiver that is interfaced with a 30 MW<sub>e</sub> turbine-generator increment to a 105 MW<sub>e</sub> base-loaded fossil plant would yield approximately a 43% annual solar capacity factor, based on SOLERGY simulations. This plant would have about 7 hours of storage (550 MWh<sub>t</sub>, or 5 times larger than Solar Two) and would be capable of dispatching power to meet a late afternoon or early evening peak power demand that is typically seen on utility-power grids (see Figure 5).

2005 Technology: The receiver in this plant is scaled-up another factor of 3.3 to 470 MW<sub>t</sub>. The receiver materials will likely be improved relative to the 316 stainless steel tubes currently used at Solar Two. Stainless is limited to a peak incident flux of about 800 suns. SunLab and Rocketdyne are currently testing advanced receiver materials that appear capable of withstanding greater than 1100 suns. This higher-concentration receiver will be able to absorb a given amount of solar energy with a smaller surface area. Reducing surface area improves efficiency because thermal losses are lowered. In addition, advanced manufacturing techniques currently being developed in a Sandia/Boeing research h project (e.g. pulled tube-to-header connections) will be employed to reduce the cost of the receiver and improve reliability.

Large-area heliostats (150 m<sup>2</sup>), similar to those successfully tested at Sandia National Laboratories [19], are expected to be used. The improved economy of scale will significantly reduce the cost of the heliostats on a \$/m<sup>2</sup> basis. In addition, increases in annual production are expected to lower heliostat costs.

A hybrid plant is again proposed to help mitigate the scale-up risk and to reduce the cost of producing solar power. System configuration could be similar to Figure 4.

A 470 MW<sub>t</sub> receiver that is interfaced with a 100 MW<sub>e</sub> turbine-generator increment to a 350 MW<sub>e</sub> base-loaded fossil plant would yield approximately a 44% annual solar capacity factor, based on SOLERGY simulations. This plant would have about 6 hours of storage (1,600 MWh<sub>t</sub>) and would be capable of dispatching power to meet a late afternoon or early evening peak power demand.

2010 Technology: In 2010, the first commercial-scale solar-only plants are assumed to be built. Scoping calculations at Sandia National Laboratories suggest that it is feasible to scale-up the receiver another factor of three to a rating of about 1,400 MW<sub>t</sub>. If this receiver is attached to a 200 MW steam generation/turbine system, 13 hours of thermal storage (6,760 MWh<sub>t</sub>) would be necessary to avoid overflow of the storage and a significant discard of solar energy. The annual capacity factor of this plant would be approximately 65%, and it would run at full turbine output nearly 24 hours/day during the summer months when the daylight hours are longer. During the winter, when days are shorter, the plant would shut down during several hours per night. Alternatively, the turbine could run at part load to maintain the turbine on line. This plant is approaching base-load operation. The same 1,400 MW<sub>t</sub> receiver/6,760 MWh<sub>t</sub> storage system could also be attached to a 400 MW steam turbine. In this case, the annual capacity factor would be about 33% and the electricity would be dispatched to meet the peaking demands of the grid. However, in this technical characterization, the power tower plant is assumed to be attached to a 200 MW<sub>e</sub> turbine.

## SOLAR POWER TOWER

2020 Technology: Power plant size is assumed to remain at 200 MW<sub>e</sub>. Power towers built between the years 2010 and 2020 should have a receiver that has a significantly higher efficiency than is currently possible with today's technology. Receivers within current power towers are coated with a highly absorptive black paint. However, the emissivity of the paint is also high which leads to a relatively large radiation loss. Future power tower receivers will be coated with a selective surface with a very low emissivity that will significantly reduce radiation losses. Selective surfaces similar to what is needed are currently used in solar parabolic trough receivers. Additional research is needed to produce a surface that won't degrade at the higher operating temperature of the tower (i.e., 650°C/1,202°F vs. 400°C/752°F). Given this improvement, scoping calculations at Sandia indicate that annual receiver efficiency should be improved to about 90%.

By 2020, further improvements in heliostat manufacturing techniques, along with significant increases in annual production, are expected to lower heliostat costs to their final mature value (~\$70/m<sup>2</sup>, see Figure 7). The reflectance of the mirrors is also expected to be improved from the current value of 94% to a value of at least 97%. Advanced reflective materials are currently being investigated in the laboratory.

As the technology reaches maturity, plant parasitics will be fully optimized and plant availability will also improve. Combining all the effects described above, annual plant efficiency is expected to be raised to 20% and annual capacity factor should be raised above 75%.

2030 Technology: No significant improvements in molten nitrate salt power tower technology are assumed beyond 2020. In order for significant improvements to continue, a radical change in power tower technology must take place. Ideas under consideration are an advanced receiver that is capable of efficiently heating air to gas-turbine temperatures (>1,400°C/2,552°F) and pressures (>1,500 kPa) in conjunction with a high-temperature phase-change thermal storage system. If this can be achieved, large solar-only plants with a combined-cycle power block efficiency of 60% or more might be achieved. In addition, as receiver temperatures exceed 1000 °C (1,832°F), thermal-chemical approaches to hydrogen generation could be exploited using solar power towers. Since these ideas are in such an early stage, no defendable cost and performance projections can be made at this time.

### 5.0 Land, Water, and Critical Materials Requirements

The land and water use values provided in Table 4 apply to the solar portion of the power plant. Land use in 1997 is taken from Solar Two design documents. Land use for years 2000 and beyond is based on systems studies [14,16]. The proper way to express land use for systems with storage is ha/MWhr/yr. Expressing land use in units of ha/MW is meaningless to a solar plant with energy storage because the effect of plant capacity factor is lost.

Water use measured at the SEGS VI and VII [20] trough plants form the basis of these estimates. Wet cooling towers are assumed. Water usage at Solar Two should be somewhat higher than at SEGS VI and VII due to a lower power block efficiency at Solar Two (33% gross). However, starting in the year 2000, water usage in a commercial power tower plant, with a high efficiency power block (42% gross), should be about 20% less than SEGS VI and VII. If adequate water is not available at the power plant site, a dry condenser-cooling system could possibly be used. Dry cooling can reduce water needs by as much as 90%. However, if dry cooling is employed, cost and performance penalties are expected to raise levelized-energy costs by at least 10%.



## SOLAR POWER TOWER

Table 4. Resource requirements.

Indicator Name	Units	Base Year 1997	2000	2005	2010	2020	2030
Land	ha/MWh/yr	$2.7 \times 10^{-3}$	$1.5 \times 10^{-3}$	$1.4 \times 10^{-3}$	$1.3 \times 10^{-3}$	$1.1 \times 10^{-3}$	$1.1 \times 10^{-3}$
Water	m <sup>3</sup> /MWh	3.2	2.4	2.4	2.4	2.4	2.4

### 6.0 References

1. Stoddard, M.C., et. al., SOLERGY - A Computer Code for Calculating the Annual Energy from Central Receiver Power Plants, Sandia National Laboratories, Livermore, CA: May 1987. Report SAND86-8060.
2. Meinecke, W., and M. Bohn, Solar Energy Concentrating Systems: Applications and Technologies, edited by M. Becker, and B. Gupta, Muller Verlag, Heidelberg, Germany, 1995.
3. Anderson, D. And K. Ahmed, The Case for the Solar Energy Investments, World Bank Technical Paper Number 279 - Energy Series, World Bank, Washington D.C.: February 1995. ISBN 0-8213-3196-5
4. Kolb, G.J., "Economic Evaluation of Solar-Only and Hybrid Power Towers Using Molten Salt Technology", Proceedings of the 8th International Symposium on Solar Thermal Concentrating Technologies, Cologne, Germany (October 6-11, 1996). Accepted for publication in the journal Solar Energy.
5. Karl W. Boer, ed., Advances in Solar Energy - An Annual Review of Research and Development, Volume 11, Chapter 1, article by Mancini, T.R., M.R. Prairie, and G.J. Kolb, American Solar Energy Society, Inc., Boulder, CO, 1997. ISBN 0-89553-254-9.
6. Akhil, A.A., S.K. Swaminathan, and R.K. Sen, Cost Analysis of Energy Storage for Electric Utility Applications, Sandia National Laboratories: February 1997. Report SAND97-0443.
7. Chiang, C. J., SUNBURN: A Computer Code for Evaluating the Economic Viability of Hybrid Solar Central Receiver Electric Power Plants, Sandia National Laboratories, Albuquerque, NM: June 1987. Report SAND86-2165.
8. Falcone, P.K., A Handbook for Solar Central Receiver Design, Sandia National Laboratories, Livermore, CA : December, 1986. Report SAND86-8009.
9. "Heliostat Cost Study for SOLMAT Program," Science Applications International Corporation, for National Renewable Energy Laboratory, Golden, CO: 1996.
10. "Heliostat Cost Study for SOLMAT Program," Solar Kinetics and Advanced Thermal Systems, for National Renewable Energy Laboratory, Golden, CO: 1996.
11. Gorman, D., Heliostat Costs at Reduced Production Volumes - Report to Sandia National Laboratories, Advanced Thermal Systems: 1993.
12. Development of a Low-Cost Drive Tracking Mechanism for Solar Heliostats or PV Arrays - Final Report, Peerless Winsmith, Inc, for Sandia National Laboratories: February 1989. Report 90-5753.

## SOLAR POWER TOWER

13. Sutton, W.F., Prices of Drives at Different Production Volumes - Report to Sandia National Labs, Peerless - Winsmith, Inc.: April 4, 1989.
14. Solar Central Receiver Technology Advancement for Electric Utility Application, Phase 1 Topical Report, Pacific Gas & Electric Company, San Francisco, CA: September 1988. Report 007.2-88.2.
15. Smith, D.C., and J.M. Chavez, A Final Report on the Phase 1 Testing of a Molten-Salt Cavity Receiver, Sandia National Laboratories, Albuquerque, NM: 1988. Report SAND87-2290.
16. Kolb, G., J. Chavez, and W. Meinecke, Second Generation Central Receiver Technologies: A Status Report, M. Becker, and P. Klimas, eds., Verlag C.F. Muller Karlsruhe, DLR, and Sandia National Laboratories: 1993. Report ISBN 3-7880-7482-5.
17. Alpert, D.J., and G.J. Kolb, Performance of the Solar One Power Plant as Simulated by the SOLERGY Computer Code, Sandia National Laboratories, Albuquerque, NM: 1988. Report SAND88-0321.
18. Central Receiver Commercialization Plan, Bechtel National Inc., for the California Energy Commission: June 1995. Report 01-0444-35-3027-2777.
19. Strachan, J.W., and R.M. Houser, Testing and Evaluation of Large-Area Heliostats for Solar Thermal Applications, Sandia National Laboratories, Albuquerque, NM: February 1993. Report SAND92-1381.
20. O&M Cost Reduction in Solar Thermal Electric Plants - 2nd Interim Report on Project Status, KJC Operating Company, for Sandia National Laboratories: July 1, 1996.

# SOLAR PARABOLIC TROUGH

## 1.0 System Description

Parabolic trough technology is currently the most proven solar thermal electric technology. This is primarily due to nine large commercial-scale solar power plants, the first of which has been operating in the California Mojave Desert since 1984. These plants, which continue to operate on a daily basis, range in size from 14 to 80 MW and represent a total of 354 MW of installed electric generating capacity. Large fields of parabolic trough collectors supply the thermal energy used to produce steam for a Rankine steam turbine/generator cycle.

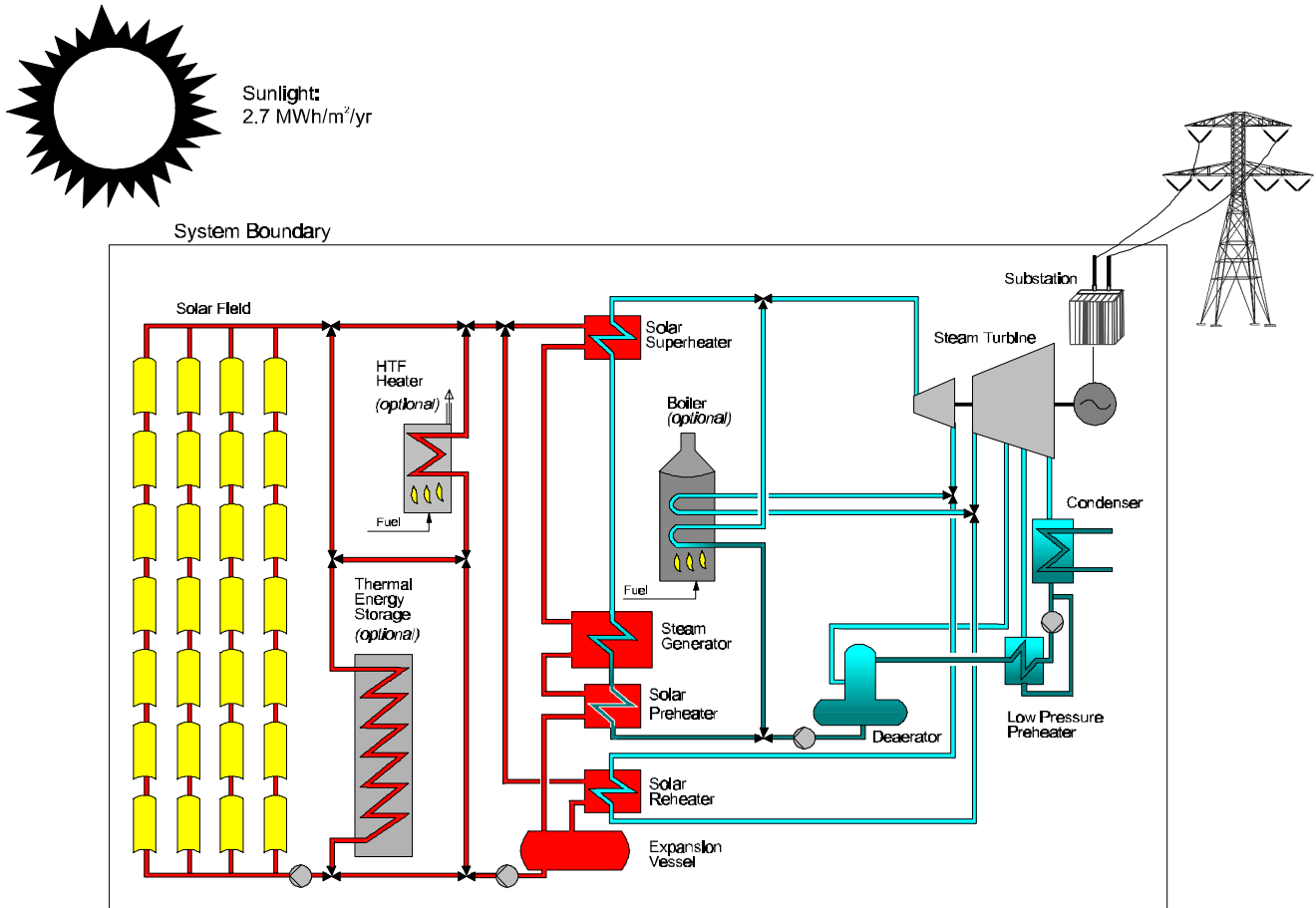

Figure 1. Solar/Rankine parabolic trough system schematic [1].

## Plant Overview

Figure 1 shows a process flow diagram that is representative of the majority of parabolic trough solar power plants in operation today. The collector field consists of a large field of single-axis tracking parabolic trough solar collectors. The solar field is modular in nature and is composed of many parallel rows of solar collectors aligned on a north-south horizontal axis. Each solar collector has a linear parabolic-shaped reflector that focuses the sun's direct beam radiation on a linear receiver located at the focus of the parabola. The collectors track the sun from east to west during the day to ensure that the sun is continuously focused on the linear receiver. A heat transfer fluid (HTF) is heated as it circulates through the receiver and returns to a series of heat exchangers in the power block where the fluid is used to

## SOLAR PARABOLIC TROUGH

generate high-pressure superheated steam. The superheated steam is then fed to a conventional reheat steam turbine/generator to produce electricity. The spent steam from the turbine is condensed in a standard condenser and returned to the heat exchangers via condensate and feedwater pumps to be transformed back into steam. Condensate cooling is provided by mechanical draft wet cooling towers. After passing through the HTF side of the solar heat exchangers, the cooled HTF is recirculated through the solar field.

Historically, parabolic trough plants have been designed to use solar energy as the primary energy source to produce electricity. The plants can operate at full rated power using solar energy alone given sufficient solar input. During summer months, the plants typically operate for 10 to 12 hours a day at full-rated electric output. However, to date, all plants have been hybrid solar/fossil plants; this means they have a backup fossil-fired capability that can be used to supplement the solar output during periods of low solar radiation. In the system shown in Figure 1, the optional natural-gas-fired HTF heater situated in parallel with the solar field, or the optional gas steam boiler/reheater located in parallel with the solar heat exchangers, provide this capability. The fossil backup can be used to produce rated electric output during overcast or nighttime periods. Figure 1 also shows that thermal storage is a potential option that can be added to provide dispatchability.

### Integrated Solar Combined Cycle System (ISCCS)

The ISCCS is a new design concept that integrates a parabolic trough plant with a gas turbine combined-cycle plant [2,3]. The ISCCS has generated much interest because it offers an innovative way to reduce cost and improve the overall solar-to-electric efficiency. A process flow diagram for an ISCCS is shown in Figure 2. The ISCCS uses solar heat to supplement the waste heat from the gas turbine in order to augment power generation in the steam Rankine bottoming cycle. In this design, solar energy is generally used to generate additional steam and the gas turbine waste heat is used for preheat and steam superheating. Most designs have looked at increasing the steam turbine size by as much as 100%. The ISCCS design will likely be preferred over the solar Rankine plant in regions where combined cycle plants are already being built.

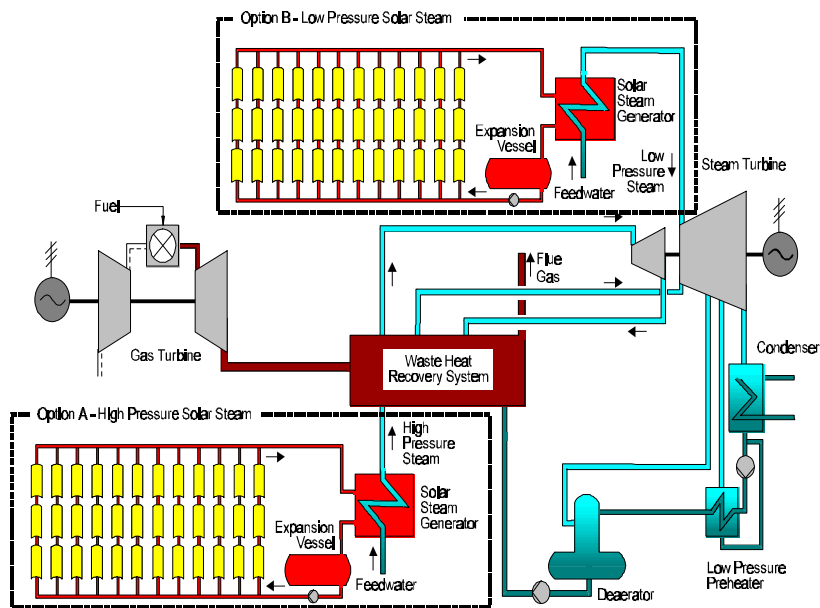

Figure 2. Integrated Solar Combined Cycle System [1].

## SOLAR PARABOLIC TROUGH

### Coal Hybrids

In regions with good solar resources where coal plants are currently used, parabolic trough plants can be integrated into the coal plant to either reduce coal consumption or add solar peaking, much like the ISCCS configuration. Due to the higher temperature and pressure steam conditions used in modern coal plants, the solar steam may need to be admitted in the intermediate or low-pressure turbine.

### History

Organized, large-scale development of solar collectors began in the U.S. in the mid-1970s under the Energy Research and Development Administration (ERDA) and continued with the establishment of the U.S. Department of Energy (DOE) in 1978. Parabolic trough collectors capable of generating temperatures greater than 500°C (932°F) were initially developed for industrial process heat (IPH) applications. Much of the early development was conducted by or sponsored through Sandia National Laboratories in Albuquerque, New Mexico. Numerous process heat applications, ranging in size from a few hundred to about 5000 m<sup>2</sup> of collector area, were put into service. Acurex, SunTec, and Solar Kinetics were the key parabolic trough manufacturers in the United States during this period.

Parabolic trough development was also taking place in Europe and culminated with the construction of the IEA Small Solar Power Systems Project/Distributed Collector System (SSPS/DCS) in Tabernas, Spain, in 1981. This facility consisted of two parabolic trough solar fields with a total mirror aperture area of 7602 m<sup>2</sup>. The fields used the single-axis tracking Acurex collectors and the double-axis tracking parabolic trough collectors developed by M.A.N. of Munich, Germany. In 1982, Luz International Limited (Luz) developed a parabolic trough collector for IPH applications that was based largely on the experience that had been gained by DOE/Sandia and the SSPS projects.

Although several parabolic trough developers sold IPH systems in the 1970s and 1980's, they generally found two barriers to successful marketing of their technologies. First, there was a relatively high marketing and engineering effort required for even small projects. Second, most potential industrial customers had cumbersome decision-making processes which often resulted in a negative decision after considerable effort had already been expended.

In 1983, Southern California Edison (SCE) signed an agreement with Acurex Corporation to purchase power from a solar electric parabolic trough power plant. Acurex was unable to raise financing for the project. Consequently, Luz negotiated similar power purchase agreements with SCE for the Solar Electric Generating System (SEGS) I and II plants. Later, with the advent of the California Standard Offer (SO) power purchase contracts for qualifying facilities under the Public Utility Regulatory Policies Act (PURPA), Luz was able to sign a number of SO contracts with SCE that led to the development of the SEGS III through SEGS IX projects. Initially, the plants were limited by PURPA to 30 MW in size; later this limit was raised to 80 MW. Table 1 shows the characteristics of the nine SEGS plants built by Luz.

In 1991, Luz filed for bankruptcy when it was unable to secure construction financing for its tenth plant (SEGS X). Though many factors contributed to the demise of Luz, the basic problem was that the cost of the technology was too high to compete in the power market. Lotker [5] describes the events that enabled Luz to successfully compete in the power market between 1984 and 1990 and many of the institutional barriers that contributed to their eventual downfall. It is important to note that all of the SEGS plants were sold to investor groups as independent power projects and continue to operate today.

## SOLAR PARABOLIC TROUGH

Table 1. Characteristics of SEGS I through IX [4].

SEGS Plant	1st Year of Operation	Net Output (MW <sub>e</sub> )	Solar Field Outlet Temp. (°C/°F)	Solar Field Area (m <sup>2</sup> )	Solar Turbine Eff. (%)	Fossil Turbine Eff. (%)	Annual Output (MWh)
I	1985	13.8	307/585	82,960	31.5	-	30,100
II	1986	30	316/601	190,338	29.4	37.3	80,500
III & IV	1987	30	349/660	230,300	30.6	37.4	92,780
V	1988	30	349/660	250,500	30.6	37.4	91,820
VI	1989	30	390/734	188,000	37.5	39.5	90,850
VII	1989	30	390/734	194,280	37.5	39.5	92,646
VIII	1990	80	390/734	464,340	37.6	37.6	252,750
IX	1991	80	390/734	483,960	37.6	37.6	256,125

### Collector Technology

The basic component of the solar field is the solar collector assembly (SCA). Each SCA is an independently tracking parabolic trough solar collector made up of parabolic reflectors (mirrors), the metal support structure, the receiver tubes, and the tracking system that includes the drive, sensors, and controls. Table 2 shows the design characteristics of the Acurex, single axis tracking M.A.N., and three generations of Luz SCAs. The general trend was to build larger collectors with higher concentration ratios (collector aperture divided by receiver diameter) to maintain collector thermal efficiency at higher fluid outlet temperatures.

Table 2. Solar collector characteristics [4,6].

Collector	Acurex 3001	M.A.N. M480	Luz LS-1	Luz LS-2		Luz LS-3
Year	1981	1984	1984	1985	1988	1989
Area (m <sup>2</sup> )	34	80	128	235		545
Aperture (m)	1.8	2.4	2.5	5		5.7
Length (m)	20	38	50	48		99
Receiver Diameter (m)	0.051	0.058	0.042	0.07		0.07
Concentration Ratio	36:1	41:1	61:1	71:1		82:1
Optical Efficiency	0.77	0.77	0.734	0.737	0.764	0.8
Receiver Absorptivity	0.96	0.96	0.94	0.94	0.99	0.96
Mirror Reflectivity	0.93	0.93	0.94	0.94	0.94	0.94
Receiver Emittance	0.27	0.17	0.3	0.24	0.19	0.19
@ Temperature (°C/°F)			300/572	300/572	350/662	350/662
Operating Temp. (°C/°F)	295/563	307/585	307/585	349/660	390/734	390/734

**Luz System Three (LS-3) SCA:** The LS-3 collector was the last collector design produced by Luz and was used primarily at the larger 80 MW plants. The LS-3 collector represents the current state-of-the-art in parabolic trough collector design and is the collector that would likely be used in the next parabolic trough plant built. A more detailed description of the LS-3 collector and its components follows.

## SOLAR PARABOLIC TROUGH

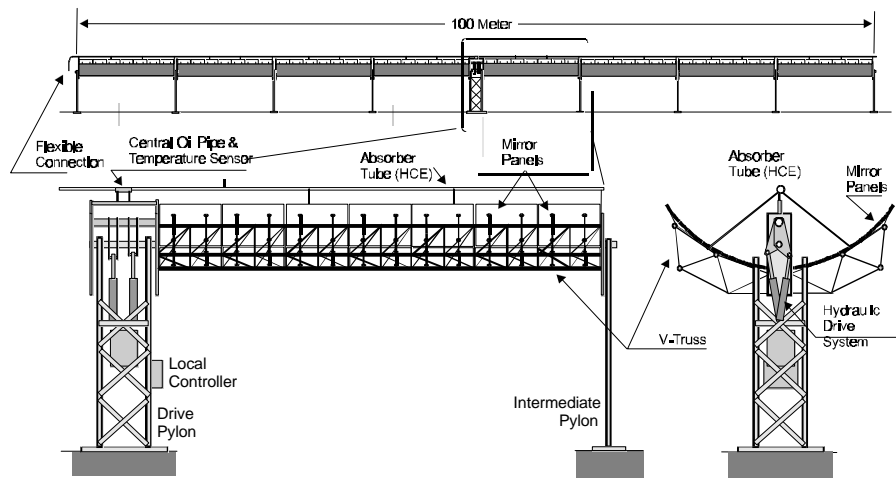

Figure 3. Luz System Three Solar Collector Assembly (LS-3 SCA) [1].

Figure 3 shows a diagram of the LS-3 collector. The LS-3 reflectors are made from hot-formed mirrored glass panels, supported by the truss system that gives the SCA its structural integrity. The aperture or width of the parabolic reflectors is 5.76 m and the overall SCA length is 95.2 m (net glass). The mirrors are made from a low iron float glass with a transmissivity of 98% that is silvered on the back and then covered with several protective coatings. The mirrors are heated on accurate parabolic molds in special ovens to obtain the parabolic shape. Ceramic pads used for mounting the mirrors to the collector structure are attached with a special adhesive. The high mirror quality allows 97% of the reflected rays to be incident on the linear receiver.

The linear receiver, also referred to as a heat collection element (HCE), is one of the primary reasons for the high efficiency of the Luz parabolic trough collector design. The HCE consists of a 70 mm steel tube with a cermet selective surface, surrounded by an evacuated glass tube. The HCE incorporates glass-to-metal seals and metal bellows to achieve the vacuum-tight enclosure. The vacuum enclosure serves primarily to protect the selective surface and to reduce heat losses at the high operating temperatures. The vacuum in the HCE is maintained at about 0.0001 mm Hg (0.013 Pa). The cermet coating is sputtered onto the steel tube to give it excellent selective heat transfer properties with an absorptivity of 0.96 for direct beam solar radiation, and a design emissivity of 0.19 at 350°C (662 °F). The outer glass cylinder has anti-reflective coating on both surfaces to reduce reflective losses off the glass tube. Getters, metallic substances that are designed to absorb gas molecules, are installed in the vacuum space to absorb hydrogen and other gases that permeate into the vacuum annulus over time.

The SCAs rotate around the horizontal north/south axis to track the sun as it moves through the sky during the day. The axis of rotation is located at the collector center of mass to minimize the required tracking power. The drive system uses hydraulic rams to position the collector. A closed loop tracking system relies on a sun sensor for the precise alignment required to focus the sun on the HCE during operation to within +/- 0.1 degrees. The tracking is controlled by a local controller on each SCA. The local controller also monitors the HTF temperature and reports operational status, alarms, and diagnostics to the main solar field control computer in the control room. The SCA is designed for normal operation in winds up to 25 mph (40 km/h) and somewhat reduced accuracy in winds up to 35 mph (56 km/h). The SCAs are designed to withstand a maximum of 70 mph (113 km/h) winds in their stowed position (the collector aimed 30° below eastern horizon).

## SOLAR PARABOLIC TROUGH

The SCA structure on earlier generations of Luz collectors was designed to high tolerances and erected in place in order to obtain the required optical performance. The LS-3 structure is a central truss that is built up in a jig and aligned precisely before being lifted into place for final assembly. The result is a structure that is both stronger and lighter. The truss is a pair of V-trusses connected by an endplate. Mirror support arms are attached to the V-trusses.

Availability of Luz Collector Technology: Although no new parabolic trough plants have been built since 1991, spare parts for the existing plants are being supplied by the original suppliers or new vendors. The two most critical and unique parts are the parabolic mirrors and the HCEs. The mirrors are being provided by Pilkington Solar International (PilkSolar) and are manufactured on the original SEGS mirror production line. The Luz HCE receiver tube manufacturing facility and technology rights were sold to SOLEL Solar Systems Ltd. of Jerusalem, Israel. SOLEL currently supplies HCEs as spare parts for the existing SEGS plants. Should a commercial opportunity arise, it is likely that a consortium of participants would form to supply Luz parabolic trough collector technology.

### SEGS Plant Operating Experience

The nine operating SEGS plants have demonstrated the commercial nature of the Luz parabolic trough collector technology and have validated many of the SEGS plant design concepts. Additionally, many important lessons have been learned related to the design, manufacture, construction, operation, and maintenance of large-scale parabolic trough plants [7,8,9].

Solar Field Components: A simple problem with a single component, such as an HCE, can affect many thousands of components in a large solar field. Thus it is essential that each of the SCA components is designed for the 30-year life of the plant and that a sufficient QA/QC program is in place to ensure that manufacture and installation adhere to design specifications. Luz used three generations of collector during the development of the nine SEGS plants. Each time a new generation of collector was used, some form of component failure was experienced. However, one of the major achievements of Luz was the speed with which they were able to respond to new problems as they were identified. Problems with components were due to design or installation flaws. An important lesson from the plants has been the recognition that O&M requirements need to be fully integrated into the design. Three components in particular are worthy of discussion because they have represented the largest problems experienced: HCEs, mirrors, and flexhoses.

Heat Collection Elements (HCEs): A number of HCE failure mechanisms have been identified at the SEGS plants, with all of these issues resolved through the development of improved installation practices and operation procedures, or through a design modification. Loss of vacuum, breakage of the glass envelope, deterioration of the selective surface, and bowing of the stainless steel tube (which eventually can lead to glass breakage) have been the primary HCE failures, all of which affect thermal efficiency. Several of the existing SEGS plants have experienced unacceptably high HCE glass envelope breakage rates. The subsequent exposure to air accelerates degradation of the selective surface. Design improvements have been identified to improve durability and performance, and these have been introduced into replacement parts manufactured for the existing plants. In addition, better installation and operational procedures have significantly reduced HCE failures. Future HCE designs should: (1) use new tube materials to minimize bowing problems; (2) allow broken glass to be replaced in-situ in the field; and (3) continue to improve the selective coating absorptance, emittance, and long-term stability in air.

Mirrors: The current low iron glass mirrors are one of the most reliable components in the Luz collectors. Separation of the mirror mounting pads from the mirrors was an early problem caused by differential thermal expansion between the mirror and the pad. This problem was resolved by using ceramic pads, a more pliable adhesive, and thermal shielding. In addition, methods have been developed that allow the O&M crew to retrofit the older mirror pad design and strengthen them to greatly reduce failures. Mirror breakage due to high winds has been observed near the edges



## SOLAR PARABOLIC TROUGH

of the solar field where wind forces can be high. Strengthened glass mirrors or thin plastic silvered film reflectors have been designed to circumvent this problem. In general, there has been no long-term degradation in the reflective quality of the mirrors; ten year old mirrors can be cleaned and brought back to like-new reflectivity. However, the glass mirrors are expensive and for the cost of the collector to be reduced, alternative mirrors are necessary. Any new mirror must be able to be washed without damaging the optical quality of the mirror. Front surface mirrors hold potential to have higher reflectivity, if the long-term performance and washability can be demonstrated.

Flexhoses: The flexhoses that connect the SCAs to the headers and SCAs to each other have experienced high failure rates at the early SEGS plants. Later plants used an improved design with a substantially increased life that significantly reduced failures. In addition, a new design that replaces the flexhoses with a hard piped assembly with ball joints is being used at the SEGS III-VII plants located at Kramer Junction. The new ball joint assembly has a number of advantages over flexhoses including lower cost, a significant reduction in pressure drop, and reduced heat losses. If ball joint assemblies can be proven to have a life comparable to the new longer-life flexhoses, then they will be included in all future trough designs.

Mirror Washing & Reflectivity Monitoring: Development of an efficient and cost-effective program for monitoring mirror reflectivity and washing mirrors is critical. Differing seasonal soiling rates require flexible procedures. For example, high soiling rates of 0.5%/day have been experienced during summer periods. After considerable experience, O&M procedures have settled on several methods, including deluge washing, and direct and pulsating high-pressure sprays. All methods use demineralized water for good effectiveness. The periodic monitoring of mirror reflectivity can provide a valuable quality control tool for mirror washing and help optimize wash labor. As a general rule, the reflectivity of glass mirrors can be returned to design levels with good washing.

Maintenance Tracking: In recent years, computerized maintenance management software (CMMS) has found wide acceptance for use in conventional fossil power plant facilities. CMMS systems can greatly enhance the planning and efficiency with which maintenance activities are carried out, reduce maintenance costs, and often result in improved availability of the power plant. CMMS programs have been implemented at trough power plants as well, but the software is not ideally suited for the solar field portion of the plant. CMMS systems excel in applications that have a thousand unique pieces of equipment, but are not really suited to handle systems with a thousand of the same kind of equipment, like SCAs in a solar field. For this reason, custom database programs have been developed to track problems and schedule maintenance in the solar plant. These programs have proven to be an essential tool for tracking and planning solar field maintenance activities and should be considered to be essential for any new project.

Collector Alignment: Operational experience has shown that it is important to be able to periodically check collector alignment and to be able to correct alignment problems when necessary. Collector designs should allow field alignment checks and easy alignment corrections.

Project Start-up Support: Operation of a solar power plant differs from conventional fossil-fuel power plant operation in several ways, primarily due to the solar field equipment and operations requirements, integration of the solar field with the power block, and the effects of cyclic operation. Much knowledge has been gained from the existing SEGS plants that is applicable to the development of procedures, training of personnel, and the establishment of an effective O&M organization.

Thermal Cycling and Daily Startup: Typically, parabolic trough plants are operated whenever sufficient solar radiation exists, and the backup fossil is only used to fill in during the highest value non-solar periods. As a result, the plants are typically shut down during the night and restarted each morning. The plants must be designed to not only be started on a daily basis, but also to start up as quickly as possible. Since the current SEGS plant design does not include thermal storage, the solar field and power block are directly coupled. The use of thermal storage can significantly

## SOLAR PARABOLIC TROUGH

mitigate these problems. In general, equipment/system design specifications and operating procedures must be developed with these requirements in mind. Both normal engineering considerations and the experience from the SEGS plants provide important inputs into these needs. Mundane design features such as valves, gaskets, and seals and bolt selection can be an expensive problem unless properly specified.

### 2.0 System Application, Benefits, and Impacts

**Large-scale Grid Connected Power:** The primary application for parabolic trough power plants is large-scale grid connected power applications in the 30 to 300 MW range. Because the technology can be easily hybridized with fossil fuels, the plants can be designed to provide firm peaking to intermediate load power. The plants are typically a good match for applications in the U.S. southwest where the solar radiation resource correlates closely with peak electric power demands in the region. The existing SEGS plants have been operated very successfully in this fashion to meet SCE's summer on-peak time-of-use rate period. Figure 4 shows the on-peak performance of the SEGS III through SEGS VII plants that are operated by KJC Operating Company. The chart shows that all 5 plants have produced greater than 100% of their rated capacity during the critical on-peak period between 1200 and 1800 PDT on weekdays during June through September. This demonstrates the continuous high availability these plants have been able to achieve. Note that 1989 was the first year of operation for SEGS VI and SEGS VII.

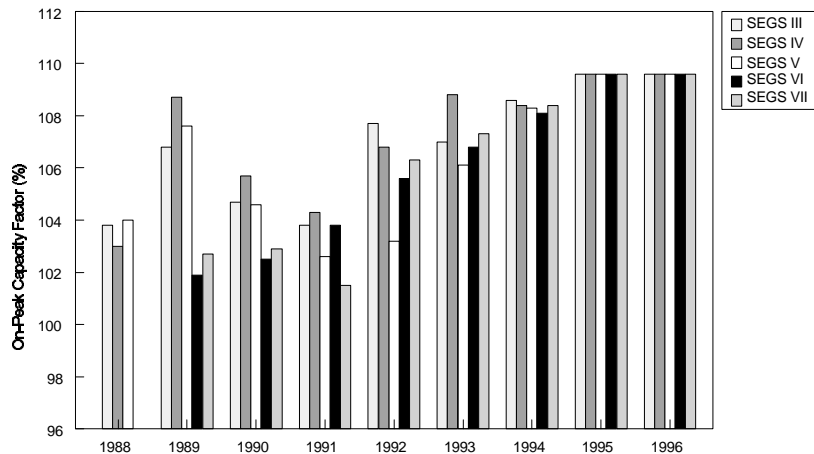

Figure 4. On-peak capacity factors for five 30 MW SEGS plants during 1988 to 1996 [10].

**Domestic Market:** The primary domestic market opportunity for parabolic trough plants is in the Southwestern deserts where the best direct normal solar resources exist. These regions also have peak power demands that could benefit from parabolic trough technologies. In particular, California, Arizona, and Nevada appear to offer some of the best opportunities for new parabolic trough plant development. However, other nearby states may provide excellent opportunities as well. The current excess of electric generating capacity in this region and the availability of low cost natural gas make future sustained deployment of parabolic trough technology in this region unlikely unless other factors come into play. However, with utility restructuring, and an increased focus on global warming and other environmental issues, many new opportunities such as renewable portfolio standards and the development of solar enterprise zones may encourage the development of new trough plants. All of the existing Luz-developed SEGS projects were developed as independent power projects and were enabled through special tax incentives and power purchase agreements such as the California SO-2 and SO-4 contracts.

## SOLAR PARABOLIC TROUGH

International Markets: With the high demand for new power generation in many developing countries, the next deployment of parabolic troughs could be abroad. Many arid regions in developing countries are ideally suited for parabolic trough technologies. India, Egypt, Morocco, Mexico, Brazil, Crete (Greece), and Tibet (China) have expressed interest in trough technology power plants. Many of these countries are already planning installations of combined cycle projects. For these countries, the trough ISCCS design may provide a cheap and low risk opportunity to begin developing parabolic trough power plants. In regions such as Brazil and Tibet that have good direct normal solar resources and existing large hydroelectric and/or pumped storage generation resources, parabolic trough technologies can round out their renewable power portfolio by providing additional generation during the dry season.

### Benefits

Least Cost Solar Generated Electricity: Trough plants currently provide the lowest cost source of solar generated electricity available. They are backed by considerable valuable operating experience. Troughs will likely continue to be the least-cost solar option for another 5-10 years depending on the rate of development and acceptance of other solar technologies.

Daytime Peaking Power: Parabolic trough power plants have a proven track record for providing firm renewable daytime peaking generation. Trough plants generate their peak output during sunny periods when air conditioning loads are at their peak. Integrated natural gas hybridization and thermal storage have allowed the plants to provide firm power even during non-solar and cloudy periods.

Environmental: Trough plants reduce operation of higher-cost, cycling fossil generation that would be needed to meet peak power demands during sunny afternoons at times when the most photochemical smog, which is aggravated by NO<sub>x</sub> emissions from power plants, is produced.

Economic: The construction and operation of trough plants typically have a positive impact on the local economy. A large portion of material during construction can generally be supplied locally. Also trough plants tend to be fairly labor-intensive during both construction and operation, and much of this labor can generally be drawn from local labor markets.

### Impacts

HTF Spills/Leaks: The current heat transfer fluid (Monsanto Therminol VP-1) is an aromatic hydrocarbon, biphenyl-diphenyl oxide. The oil is classified as non-hazardous by U.S. standards but is a hazardous material in the state of California. When spills occur, contaminated soil is removed to an on-site bio-remediation facility that utilizes indigenous bacteria in the soil to decompose the oil until the HTF concentrations have been reduced to acceptable levels. In addition to liquid spills, there is some level of HTF vapor emissions from valve packing and pump seals during normal operation [11]. Although the scent of these vapor emissions is often evident, the emissions are well within permissible levels.

Water: Water availability can be a significant issue in the arid regions best suited for trough plants. The majority of water consumption at the SEGS plants (approximately 90%) is used by the cooling towers. Water consumption is nominally the same as it would be for any Rankine cycle power plant with wet cooling towers that produced the same level of electric generation. Dry cooling towers can be used to significantly reduce plant water consumption; however, this can result in up to a 10% reduction in power plant efficiency. Waste water discharge from the plant is also an issue. Blowdown from the steam cycle, demineralizer, and cooling towers must typically be sent to an evaporation pond due to the high mineral content or due to chemicals that have been added to the water. Water requirements are shown in Section 5.

## SOLAR PARABOLIC TROUGH

Land: Parabolic trough plants require a significant amount of land that typically cannot be used concurrently for other uses. Parabolic troughs require the land to be graded level. One opportunity to minimize the development of undisturbed lands is to use parcels of marginal and fallow agricultural land instead. A study sponsored by the California Energy Commission determined that 27,000 MW<sub>e</sub> of STE plants could be built on marginal and fallow agricultural land in Southern California [12]. A study for the state of Texas showed that land use requirements for parabolic trough plants are less than those of most other renewable technologies (wind, biomass, hydro) and also less than those of fossil when mining and drilling requirements are included [13]. Current trough technology produces about 100 kWh/yr/m<sup>2</sup> of land.

Hybrid Operation: Solar/fossil hybrid plant designs will operate with fossil fuels during some periods. During these times, the plant will generate emissions consistent with the fuel.

### 3.0 Technology Assumptions and Issues

Trough Technology: The experience from the nine SEGS plants demonstrates the commercial nature of parabolic trough solar collector and power plant technologies. Given this experience, it is assumed that future parabolic trough plant designs will continue to focus on the Luz parabolic trough collector technology and Rankine cycle steam power plants. The next plants built are assumed to copy the 80 MW SEGS plant design and use the third generation Luz System Three parabolic trough collector.

Cost and Performance Data: The information presented is based on existing SEGS plant designs and operational experience. In addition, much of the cost data comes from PilkSolar [1] who has been actively pursuing opportunities for parabolic trough developments in many international locations. Performance projections assume a solar resource that would be typical for plants located in the California Mojave Desert. PilkSolar developed a detailed hour-by-hour simulation code to calculate the expected annual performance of parabolic trough plants. This model has been validated by baselining it against an operating SEGS plant. The model was found to reproduce real plant performance within 5% on an annual basis. The model can be used to perform design trade-off studies with a reasonable level of confidence.

Power Plant Size: Increasing plant size is one of the easiest ways to reduce the cost of solar electricity from parabolic trough power plants. Studies have shown that doubling the size reduces the capital cost by approximately 12-14% [1]. Figure 5 shows an example of how the levelized energy cost for solar electricity decreases by over 60% by only increasing the plant size. Cost reduction typically comes from three areas. First, the increased manufacturing volume of collectors for larger plants drives the cost per square meter down. Second, a power plant that is twice the size will not cost twice as much to build. Third, the O&M costs for larger plants will typically be less on a per kilowatt basis. For example, it takes about the same number of operators to operate a 10 MW plant as it does a 400 MW plant [2]. Power plant maintenance costs will be reduced with larger plants but solar field maintenance costs will scale more linearly with solar field size.

## SOLAR PARABOLIC TROUGH

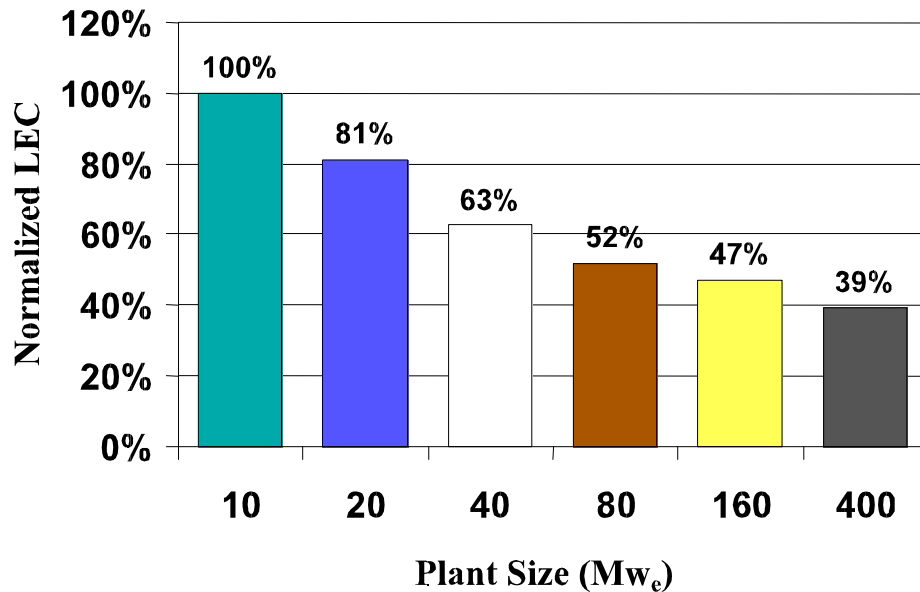

Figure 5. Effect of power plant size on normalized levelized COE.

The latest parabolic trough plants built were 80 MW in size. This size was a result of limitations imposed by the Federal government. Luz had investigated sizes up to 160 MW. The main concern with larger plants is the increased size of the solar field which impacts HTF pumping parasitics. In future plants, pumping parasitics will be reduced by replacing the flexible hoses with the new ball joint assemblies [8], allowing for plants in excess of the 160 MW size to be built.

Hybridization: Hybridization with a fossil fuel offers a number of potential benefits to solar plants including: reduced risk to investors, improved solar-to-electric conversion efficiency, and reduced levelized cost of energy from the plant [14]. Furthermore, it allows the plant to provide firm, dispatchable power.

Since fossil fuel is currently cheap, hybridization of a parabolic trough plant is assumed to provide a good opportunity to reduce the average cost of electricity from the plant. Hybridizing parabolic trough plants has been accomplished in a number of ways. All of the existing SEGS plants are hybrid solar/fossil designs that are allowed to take up to 25% of their annual energy input to the plant from fossil fuel. Fossil energy can be used to superheat solar generated steam (SEGS I), fossil energy can be used in a separate fossil-fired boiler to generate steam when insufficient solar energy is available (SEGS II-VII), or fossil energy can be used in an oil heater in parallel with the solar field when insufficient solar energy is available (SEGS VIII-IX). The decision on type of hybridization has been primarily an economic decision. However, it is clear from the SEGS experience that hybridization of the plants has been essential to the operational success of the projects.

The alternative ISCCS design offers a number of potential advantages to both the solar plant and the combined cycle plant. The solar plant benefits because the incremental cost of increasing the size of the steam turbine in the combined cycle is significantly less than building a complete stand-alone power plant. O&M costs are reduced because the cost of operation and maintenance on the conventional portion of the plant is covered by the combined cycle costs. Also, the net annual solar-to-electric efficiency is improved because solar input is not lost waiting for the turbine plant to start up, and because the average turbine efficiency will be higher since the turbine will always be running at 50% load or above. The combined cycle benefits because the fossil conversion efficiency is increased during solar operation since

## SOLAR PARABOLIC TROUGH

the gas turbine waste heat can be used more efficiently. Solar output will also help to offset the normal reduction in performance experienced by combined cycle plants during hot periods. Figure 6 shows how the LEC for an 80 M W solar increment ISCCS plant compares to those of a solar only SEGS and a conventional hybrid SEGS plant.

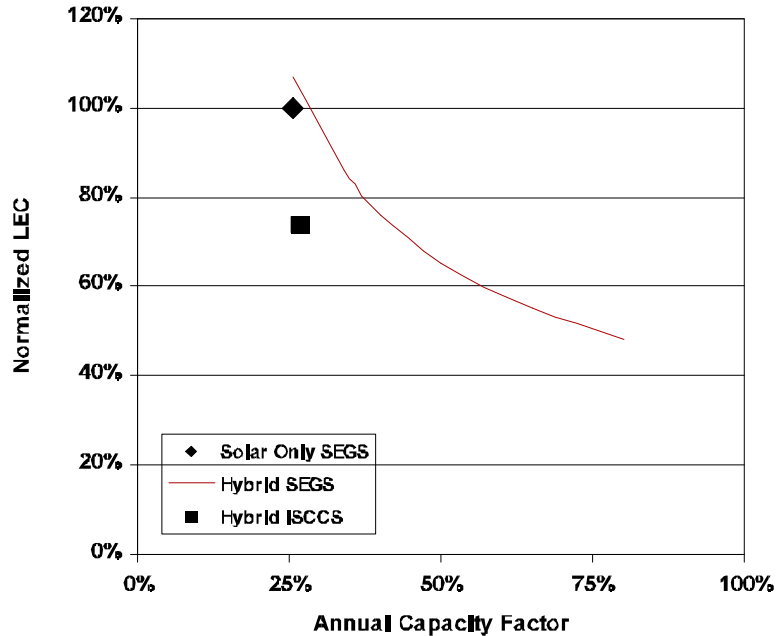

Figure 6. Effect of hybridization on LEC.

**Thermal Storage:** The availability of efficient and low-cost thermal storage is important for the long-term cost reduction of trough technology and significantly increases potential market opportunities. A parabolic trough plant with no fossil backup or thermal storage, located in the Mojave Desert, should be capable of producing electricity up to about a 25% annual capacity factor. The addition of thermal storage could allow the plant to dispatch power to non-solar times of the day and could allow the solar field to be oversized to increase the plant's annual capacity factor to about 50%. Attempting to increase the annual capacity factor much above 50% would result in significant dumping of solar energy during summer months. An efficient 2-tank HTF thermal storage system has been demonstrated at the SEGS I plant. However, it operates at a relatively low solar field HTF outlet temperature (307°C/585 °F), and no cost effective thermal storage system has yet been developed for the later plants that operate at higher HTF temperatures (390°C/734°F) and require a more stable (and expensive) HTF. A study of applicable thermal storage concepts for parabolic trough plants has recommended a concrete and steel configuration, though other methods are possible [6].

**Advanced Trough Collector:** One of the main performance improvements possible for single axis tracking parabolic trough collectors is to tilt the axis of rotation above horizontal. Luz looked at tilting their LS-4 design 8° above horizontal and estimated a 9% increase in annual solar field performance.

**Direct Steam Generation (DSG):** In the DSG concept, steam is generated directly in the parabolic trough collectors. This saves cost by eliminating the need for the HTF system and reduces the efficiency loss of having to use a heat exchanger to generate steam. The solar field operating efficiency should improve due to lower average operating temperatures and improved heat transfer in the collector. The trough collectors require some modification due to the higher operating pressure and lower fluid flow rates. Control of a DSG solar field will likely be more complicated than the HTF systems and may require a more complex design layout and a tilted collector. DSG offers a number of

## SOLAR PARABOLIC TROUGH

advantages over current HTF systems, but controllability and O&M risks have yet to be resolved. A pilot demonstration of DSG technology is in progress at the Plataforma Solar de Almería in Spain [15].

Project Development Issues: The environment in which a trough project is developed will have a significant impact on the eventual cost of the technology. As mentioned in the Overview of Solar Thermal Technologies, building multiple plants in a solar power park environment, the type of project financing, and access to incentives which levelize the tax burden between renewables and conventional power technologies can dramatically improve the economics of STE technologies. Although project financing and tax equity issues are not addressed in this document, the technology cases presented in Section 4 assume that multiple projects are built at the same site in a solar power park environment. This assumption seems reasonable since a stand-alone plant would be significantly more expensive and less likely to be built.

Performance Adjustment Factor for Solar Radiation at Different Sites: Direct normal insolation (DNI) resources vary widely by location. The performance projections presented in the following sections assume a solar resource equivalent to Barstow, California. Table 3 shows the DNI resources for other locations [2,16] and the approximate change in performance that might be expected due to the different solar radiation resources. From Table 3 it can be seen that a 1% change in DNI results in a greater than 1% change in electric output. It is important to note that the table does not correct for latitude which can have a significant impact on solar performance. In general, solar field size can be increased to offset reduced performance resulting from lower clear sky radiation levels, but increased size cannot help reductions resulting from increased cloud cover, unless the plant also includes thermal storage.

### 4.0 Performance and Cost

Table 4 summarizes the performance and cost indicators for the parabolic trough system characterized in this report.

#### 4.1 Evolution Overview

The parabolic trough plant technology discussion presented focuses on the development of Luz parabolic trough collector designs and the continued use of Rankine cycle steam power plants. Although the ISCCS concept is likely to be used for initial reintroduction of parabolic trough plants and could continue to be a popular design alternative for some time into the future, the approach used here is to look at how parabolic trough plants will need to develop if they are going to be able to compete with conventional power technologies and provide a significant contribution to the world's energy mix in the future. To achieve these long-term objectives, trough plants will need to continue to move towards larger solar only Rankine cycle plants and develop efficient and cost effective thermal storage to increase annual capacity factors.

## SOLAR PARABOLIC TROUGH

Table 3. Solar radiation performance adjustment .

Location	Site Latitude	Annual DNI (kWh/m <sup>2</sup> )	Relative Solar Resource	Relative Solar Electric Output
<b>United States</b>				
Barstow, California	35°N	2,725	1.00	1.00
Las Vegas, Nevada	36°N	2,573	0.94	0.93
Tucson, Arizona	32°N	2,562	0.94	0.92
Alamosa, Colorado	37°N	2,491	0.91	0.89
Albuquerque, New Mexico	35°N	2,443	0.90	0.87
El Paso, Texas	32°N	2,443	0.90	0.87
<b>International</b>				
Northern Mexico	26-30°N	2,835	1.04	1.05
Wadi Rum, Jordan	30°N	2,500	0.92	0.89
Ouarzazate, Morocco	31°N	2,364	0.87	0.83
Crete	35°N	2,293	0.84	0.79
Jodhpur, India	26°N	2,200	0.81	0.75

**1997 Technology:** The 1997 baseline technology is assumed to be the 30 MW SEGS VI plant [17]. The SEGS VI plant is a hybrid solar/fossil plant that uses 25% fossil input to the plant on an annual basis in a natural gas-fired steam boiler. The plant uses the second generation Luz LS-2 parabolic trough collector technology. The solar field is composed of 800 LS-2 SCAs (188,000 m<sup>2</sup> of mirror aperture) arranged in 50 parallel flow loops with 16 SCAs per loop. Similar to the 80 MW plants, the power block uses a reheat steam turbine and the solar field operates at the same HTF outlet temperature of 390°C (734°F). Solar steam is generated at 10 MPa and 371°C (700°F). The plant is hybridized with a natural gas fired steam boiler which generates high pressure steam at 10 MPa and 510°C (950 °F).

**2000 Technology:** The year 2000 plant is assumed to be the next parabolic trough plant built which is assumed to be the 80 MW SEGS X design [4]. The primary changes from the 1997 baseline technology is that this plant size increases to 80 MW, the LS-3 collector is used in place of the LS-2, the HCE uses an improved selective coating, and flex hoses have been replaced with ball joint assemblies. The solar field is composed of 888 LS-3 SCAs (510,120 m<sup>2</sup> of mirror aperture) arranged in 148 parallel flow loops with 6 SCAs per loop. The plant is hybridized with a natural gas fired HTF heater.

**2005 Technology:** The power plant is scaled up to 160 MW. Six hours of thermal storage is added to the plant to allow the plant to operate at up to a 40% annual capacity factor from solar input alone. No backup fossil operating capability is included. The LS-3 parabolic trough collector continues to be used, but the solar field size is scaled up to allow the plant to achieve higher annual capacity factor using 2,736 SCAs (1,491,120 m<sup>2</sup> of mirror aperture) arranged in 456 parallel flow loops with 6 SCAs per loop.

**2010 Technology:** The power plant is scaled up to 320 MW and operates to an annual capacity factor of 50% from solar input. Again no fossil backup operation is included. This design incorporated the next generation of trough h



Table 4. Performance and cost indicators.

INDICATOR NAME	UNITS	1997 SEGS VI* Base Case		2000 SEGS LS-3 25% Fossil †		2005 SEGS LS-3 w/Storage		2010 SEGS LS-4 w/Storage		2020 SEGS DSG w/Storage		2030 SEGS DSG w/Storage	
			+/-%		+/-%		+/-%		+/-%		+/-%		+/-%
Plant Design													
Plant Size	MW	30		80		161		320		320		320	
Collector Type		LS-2		LS-3		LS-3		LS-4		LS-4		LS-4	
Solar Field Area	m <sup>2</sup>	188,000		510,120		1,491,120		3,531,600		3,374,640		3,204,600	
Thermal Storage	Hours	0		0		6		10		10		10	
	MWh <sub>t</sub>	0		0		3,000		10,042		9,678		9,678	
Performance													
Capacity Factor	%	34		34		40		50		50		50	
Solar Fraction (Net Elec.)	%	66		75		100		100		100		100	
Direct Normal Insolation	kWh/m <sup>2</sup> -yr	2,891		2,725		2,725		2,725		2,725		2,725	
Annual Solar to Elec. Eff.	%	10.7		12.9		13.8		14.6		15.3		16.1	
Natural Gas (HHV)	GJ	350,000		785,000		0		0		0		0	
Annual Energy Production	GWh/yr	89.4		238.3		564.1		1,401.6		1,401.6		1,401.6	
Development Assumptions													
Plants Built Per Year		2		2		2		3		3		3	
Plants at a Single Site		5		5		5		5		5		5	
Competitive Bidding Adj.		1.0		1.0		0.9		0.9		0.9		0.9	
O&M Cost Adjustment		1.0		0.9		0.85		0.7		0.6		0.6	
Operations and Maintenance Cost													
Labor	\$/kW-yr			32	25	21	25	14	25	11	25	11	25
Materials				31	25	31	25	29	25	23	25	23	25
Total O&M Costs		107		63		52		43		34		34	

Notes:

1. The columns for "+/- %" refer to the uncertainty associated with a given estimate.

2. The construction period is assumed to be 1 year.

3. Totals may be slightly off due to rounding.

\* SEGS VI Capital cost of \$99.3M in 1989\$ is adjusted to \$119.2M in 1997\$. Limited breakdown of costs by subsystem is available. Performance and O&M costs based on actual data.

† By comparison, an ISCCS plant built in 2000 with an 80 MW solar increment would have a solar capital cost of \$2,400/kW, annual O&M cost of \$48/kW, and an annual net solar-to-electric efficiency of 13.5%[1].

‡ To convert to peak values, the effect of thermal storage must be removed. A first-order estimate can be obtained by dividing installed costs by the solar multiple (i.e.,  $SM = \frac{\text{peak collected solar thermal power}}{\text{power block thermal power}}$ ).

Table 4. Performance and cost indicators.(cont.)

INDICATOR NAME	UNITS	1997		2000		2005		2010		2020		2030	
		SEGS VI* Base Case	+/-%	SEGS LS-3 25% Fossil †	+/-%	SEGS LS-3 w/Storage	+/-%	SEGS LS-4 w/Storage	+/-%	SEGS DSG w/Storage	+/-%	SEGS DSG w/Storage	+/-%
<b>Capital Cost</b>													
Structures/Improvements	\$/kW	54		79	15	66	15	62	15	60	15	58	15
Collector System		3,048		1,138	25	1,293	25	1,327	25	1,275	25	1,158	25
Thermal Storage System		0		0		392	+50/-25	528	+50/-25	508	+50/-25	508	+50/-25
Steam Gen or HX System				109	15	90	15	81	15	80	15	79	15
Aux Heater/Boiler		120		164	15	0	15	0	15	0	15	0	15
Electric Power Generation				476	15	347	15	282	15	282	15	282	15
Balance of Plant		750		202	15	147	15	120	15	120	15	120	15
Subtotal (A)		3,972		2,168		2,336		2,400		2,326		2,205	
Engr, Proj./Const. Manag.	A * 0.08			174		187		192		186		176	
Subtotal (B)		3,972		2,342		2,523		2,592		2,512		2,382	
Project/Process Conting	B * 0.15			351		378		389		377		357	
Total Plant Cost		3,972		2,693		2,901		2,981		2,889		2,739	
Land @ \$4,942/ha				11		15		18		17		17	
Total Capital Requirements	\$/kW	3,972		2,704		2,916		2,999		2,907		2,756	
	\$/kW <sub>peak</sub> ‡	3,972		2,704		1,700		1,400		1,350		1,300	
	\$/m <sup>2</sup>	634		424		315		272		276		275	
<b>Operations and Maintenance Cost</b>													
Labor	\$/kW-yr			32	25	21	25	14	25	11	25	11	25
Materials				31	25	31	25	29	25	23	25	23	25
Total O&M Costs		107		63		52		43		34		34	

Notes:

1. The columns for "+/- %" refer to the uncertainty associated with a given estimate.
2. The construction period is assumed to be 1 year.
3. Totals may be slightly off due to rounding.

\* SEGS VI Capital cost of \$99.3M in 1989\$ is adjusted to \$119.2M in 1997\$. Limited breakdown of costs by subsystem is available. Performance and O&M costs based on actual data.

† By comparison, an ISCCS plant built in 2000 with an 80 MW solar increment would have a solar capital cost of \$2,400/kW, annual O&M cost of \$48/kW, and an annual net solar-to-electric efficiency of 13.5%[1].

‡ To convert to peak values, the effect of thermal storage must be removed. A first-order estimate can be obtained by dividing installed costs by the solar multiple (i.e.,  $SM = \{\text{peak collected solar thermal power}\} \div \{\text{power block thermal power}\}$ ).

## SOLAR PARABOLIC TROUGH

collector, possibly something like the Luz LS-4 advanced trough collector (over 3,500,000 m<sup>2</sup> of mirror aperture). The solar field continues to use a heat transfer fluid but the collector is assumed to have a fixed tilt of 8°.

2020 - 2030 Technology: Power plant size is assumed to remain at 320 MW with 50% annual capacity factor. This design assumes the technology will incorporate direct steam generation (DSG) into the collector in the solar field (over 3,200,000 m<sup>2</sup> of mirror aperture).

### 4.2 Performance and Cost Discussion

#### Plant Performance

Increasing the performance of the solar collectors and power plant are one of the primary opportunities for reducing the cost of trough technology. Collector performance improvements can come from developing new more efficient collector technologies and components but often also by improving the reliability and lifetime of existing components. Table 4 shows the annual performance and net solar-to-electric efficiency of each of the technology cases described above.

The 1997 baseline case performance represents the actual 1996 performance of the 30 MW SEGS VI plant (its 8th year of operation). During 1996, the SEGS VI plant had an annual net solar-to-electric efficiency of 10.7% [10,18]. This performance was somewhat reduced by the high level of HCE breakage at the plant (5% with broken glass and 1% with lost vacuum). Since the HCE problems at SEGS VI are due to a design error that was later corrected, we assume that HCE breakage at future plants should remain below 1%, a number consistent with the experience at the SEGS V plant. The SEGS VI plant was selected as the baseline system because substantially more cost and performance data is available and more analysis of plant performance has been completed than at either of the existing 80 MW SEGS plants. Note, even though only 25% of the annual energy input to the plant comes from natural gas, since this energy is converted only at the highest turbine cycle efficiency, 34% of the annual electric output from the plant comes from gas energy.

The year 2000 technology shows a 20% improvement in net solar to electric efficiency over the 1997 baseline system performance. This is achieved by using current technologies and designs, by reducing HCE heat losses and electric parasitics. New HCEs have an improved selective surface with a higher absorptance and a 50% lower emittance. This helps reduce trough receiver heat losses by one third. The ball joint assemblies and the reduced number of SCAs per collector loop (6 for LS-3 versus 16 for LS-2 collectors) will reduce HTF pumping parasitics. Adjusting for reduced parasitics, improved HCE selective surface, and lower HCE breakage, a new 80 MW plant would be expected to have a net solar-to-electric efficiency of 12.9%.

The 2005 technology shows a 7% increase in efficiency primarily as a result of adding thermal storage. Thermal storage eliminates dumping of solar energy during power plant start-up and during peak solar conditions when solar field thermal delivery is greater than power plant capacity. Thermal storage also allows the power plant to operate independently of the solar field. This allows the power plant to operate near full load efficiency more often, improving the annual average power block efficiency. The thermal storage system is assumed to have an 85% round-trip efficiency. Minor performance improvements also result from scaling the plant up to 160 MW from 80 MW. Annual net solar-to-electric efficiency increases to 13.8% [1].

The 2010 technology shows a 6% increase in net solar-to-electric efficiency primarily due to the use of the tilted collector. Power plant efficiency improves slightly due to larger size of the 320 MW power plant. Thermal storage has been increased to 10 hours and the solar field size increased to allow the plant to operate up to a 50% annual

## SOLAR PARABOLIC TROUGH

capacity factor. As a result, more solar energy must be stored before it can be used to generate electricity, thus the 85% round-trip efficiency of the thermal storage system tends to have a larger impact on annual plant performance. The resulting annual net solar-to-electric efficiency increases to 14.6%.

The 2020 and 2030 technologies show 5% and 10% improvements in performance over the 2010 trough technology. This is due to the introduction of the direct steam generation trough collector technology. DSG improves the efficiency in the solar field and reduces equipment costs by eliminating the HTF system. Power cycle efficiency is assumed to improve due to higher solar steam temperatures. Solar parasitics are reduced through elimination of HTF pumps. Although feedwater must still be pumped through the solar field, it is pumped at a much lower mass flow rate. This design also assumes that a low cost thermal storage system with an 85% round-trip efficiency is developed for use with the DSG solar field. Conversion to the DSG collector system could allow the net solar-to-electric efficiency to increase to over 16% by 2030. The changes between 2020 and 2030 are assumed to be evolutionary improvements and fine tuning of the DSG technology.

### Cost Reductions

Table 4 shows the total plant capital cost for each technology case on a \$/kW/m<sup>2</sup> basis. The technology shows a 30% cost reduction on a \$/kW basis and a 55% reduction on a \$/m<sup>2</sup> basis. These cost reductions are due to: larger plants being built, increased collector production volumes, building projects in solar power park developments, and savings through competitive bidding. In general, the per kW capital cost of power plants decreases as the size of the plant increases. For trough plants, a 49% reduction in the power block equipment cost results by increasing the power plant size from 30 to 320 MW. The increased production volume of trough solar collectors, as a result of larger solar fields and multiple plants being built in the same year, reduces trough collector costs by 44%. Power parks allow for efficiencies in construction and cost reduction through competitive bidding of multiple projects. A 10% cost reduction is assumed for competitive bidding in later projects.

The annual operation and maintenance (O&M) costs for each technology are shown in Table 4. O&M costs show a reduction of almost 80%. This large cost reduction is achieved through increasing size of the power plant, increasing the annual solar capacity factor, operating plants in a solar power park environment, and continued improvements in O&M efficiencies. Larger plants reduce operator labor costs because approximately the same number of people are required to operate a 320 MW plant as are required for a 30 MW plant. The solar power park assumes that five plants are co-located and operated by the same company resulting in a 25% O&M savings through reduced overhead and improved labor and material efficiencies. In addition, about one third of the cost reduction is assumed to occur because of improved O&M efficiency resulting from improved plant design and O&M practices based on the results of the KJC O&M Cost Reduction Study [8].

### Summary

The technology cases presented above show that a significant increase in performance and reduction in cost is possible for parabolic trough solar thermal electric technologies as compared with the 1997 baseline technology case. Figure 7 shows the relative impacts of the various cost reduction opportunities or performance improvements on the baseline system's levelized cost of energy. It is significant to note that the majority of the cost reduction opportunities do not require any significant technology development. Conversely, significant progress must be made in these non-technology areas if parabolic troughs are to be competitive with conventional power technologies and make an significant market penetration.

## SOLAR PARABOLIC TROUGH

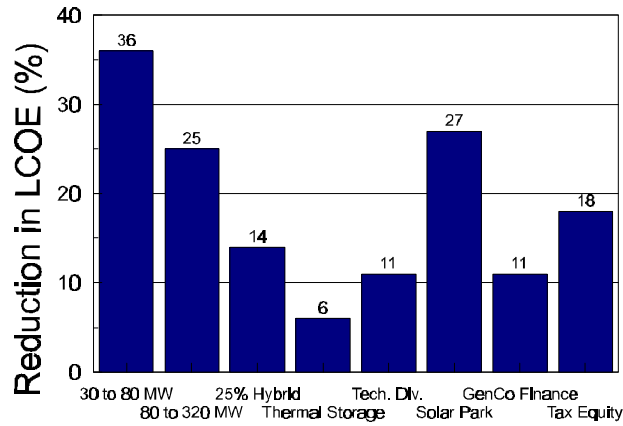

Figure 7. Cost reduction opportunities for parabolic trough plants.

### 5.0 Land, Water, and Critical Materials Requirements

Land and water requirements are shown in the table below for each of the technology cases. The land and water requirements initially increase as a result of increasing plant annual operating capacity factors. The land requirements begin to decrease as a result of improving solar-to-electric efficiencies. Note, the plant capacity factor increases over time because future plants are assumed to include thermal storage and proportionally larger solar fields.

Table 4. Resource requirements [2].

Indicator Name	Units	Base Year					
		1997	2000	2005	2010	2020	2030
Plant Size	MW	30	80	161	320	320	320
Land	ha/MW	2.2	2.2	3.1	3.7	3.6	3.4
	ha	66	176	500	1,190	1,150	1,090
Water	m <sup>3</sup> /MW-yr	18,500	14,900	17,500	21,900	21,900	21,900

### 6.0 References

1. Status Report on Solar Thermal Power Plants, Pilkington Solar International: 1996. Report ISBN 3-9804901-0-6.
2. Assessment of Solar Thermal Trough Power Plant Technology and Its Transferability to the Mediterranean Region - Final Report, Flachglas Solartechnik GMBH, for European Commission Directorate General I External Economic Relations, and Centre de Developpement des Energies Renouvelables and Grupo Endesa, Cologne, Germany: June 1994.

## SOLAR PARABOLIC TROUGH

3. Integrated Solar Combined Cycle Systems (ISCCS) Using Parabolic Trough Technology, Phase 1B Technical and Financial Review, Spencer Management Associates, Diablo, CA: March 1996, draft.
4. "Solar Electric Generating System IX Technical Description", LUZ International Limited: 1990.
5. Lotker, M., Barriers to Commercialization of Large-Scale Solar Electricity: Lessons Learned from the LUZ Experience, Sandia National Laboratories, Albuquerque, New Mexico: 1991. Report SAND91-7014.
6. Winter, C.-J., R. Sizmann, and L. Vant-Hull, eds., Solar Power Plants - Fundamentals, Technology, Systems, Economics. Springer-Verlag, Berlin, 1990, ISBN 3-540-18897-5.
7. O&M Cost Reduction in Solar Thermal Electric Power Plants - Interim Report on Project Status, KJC Operating Company, for Sandia National Laboratories: September 1, 1994.
8. O&M Cost Reduction in Solar Thermal Electric Power Plants - 2nd Interim Report on Project Status, KJC Operating Company, for Sandia National Laboratories: July 1, 1996.
9. Dudley, V., G. Kolb, A. R. Mahoney, T. Mancini, C. Matthews, M. Sloan, and D. Kearney, Test Results: SEGS LS-2 Solar Collector, Sandia National Laboratories, Albuquerque, New Mexico: December 1994. Report SAND94-1884.
10. Cohen, G., and S. Frier, "Ten Years of Solar Power Plant Operation in the Mojave Desert", Proceedings of Solar 97, the 1997 ASES Annual Conference, Washington, D.C. (April, 1997).
11. Fugitive Emissions Testing - Final Report, AeroVironment, Inc., for KJC Operating Company, Monrovia, CA: January 1995.
12. Technical Potential of Alternative Technologies - Final Report, Regional Economic Research, Inc., for California Energy Commission, Contract No. 500-89-001, San Diego, CA: December 2, 1991.
13. Texas Renewable Energy Resource Assessment: Survey, Overview & Recommendations, Virtus Energy Research Associates, for the Texas Sustainable Energy Development Council, July, 1995, ISBN 0-9645526-0-4.
14. Williams, T., M. Bohn, and H. Price, "Solar Thermal Electric Hybridization Issues", Proceedings of the ASME/JSME/JSES International Solar Energy Conference, Maui, HI (March 19-24, 1995).
15. Muller, M., Direct Solar Steam in Parabolic Trough Collectors (DISS), Plataforma Solar de Almeria (PSA), CIEMAT and DLR, May, 1994, ISBN 84-605-1479-X.
16. Marion, W., and S. Wilcox, Solar Radiation Data Manual for Flat-Plate and Concentrating Collectors, National Renewable Energy Laboratory, Golden, Colorado: April 1994. Report NREL/TP-463-5607.
17. Kearney, D., and C. Miller, Solar Electric Generating System VI - Technical Evaluation of Project Feasibility, LUZ Partnership Management, Inc.: January 15, 1988.

## **SOLAR PARABOLIC TROUGH**

18. Kolb, G. J., "Evaluation of Power Production from the Solar Electric Generating Systems at Kramer Junction: 1988 to 1993", Solar Engineering - 1995, Proceedings of the ASME Solar Energy Conference, Maui, HI (March 19-24, 1995).

# SOLAR DISH ENGINE

## 1.0 System Description

Dish/engine systems convert the thermal energy in solar radiation to mechanical energy and then to electrical energy in much the same way that conventional power plants convert thermal energy from combustion of a fossil fuel to electricity. As indicated in Figure 1, dish/engine systems use a mirror array to reflect and concentrate incoming direct normal insolation to a receiver, in order to achieve the temperatures required to efficiently convert heat to work. This requires that the dish track the sun in two axes. The concentrated solar radiation is absorbed by the receiver and transferred to an engine.

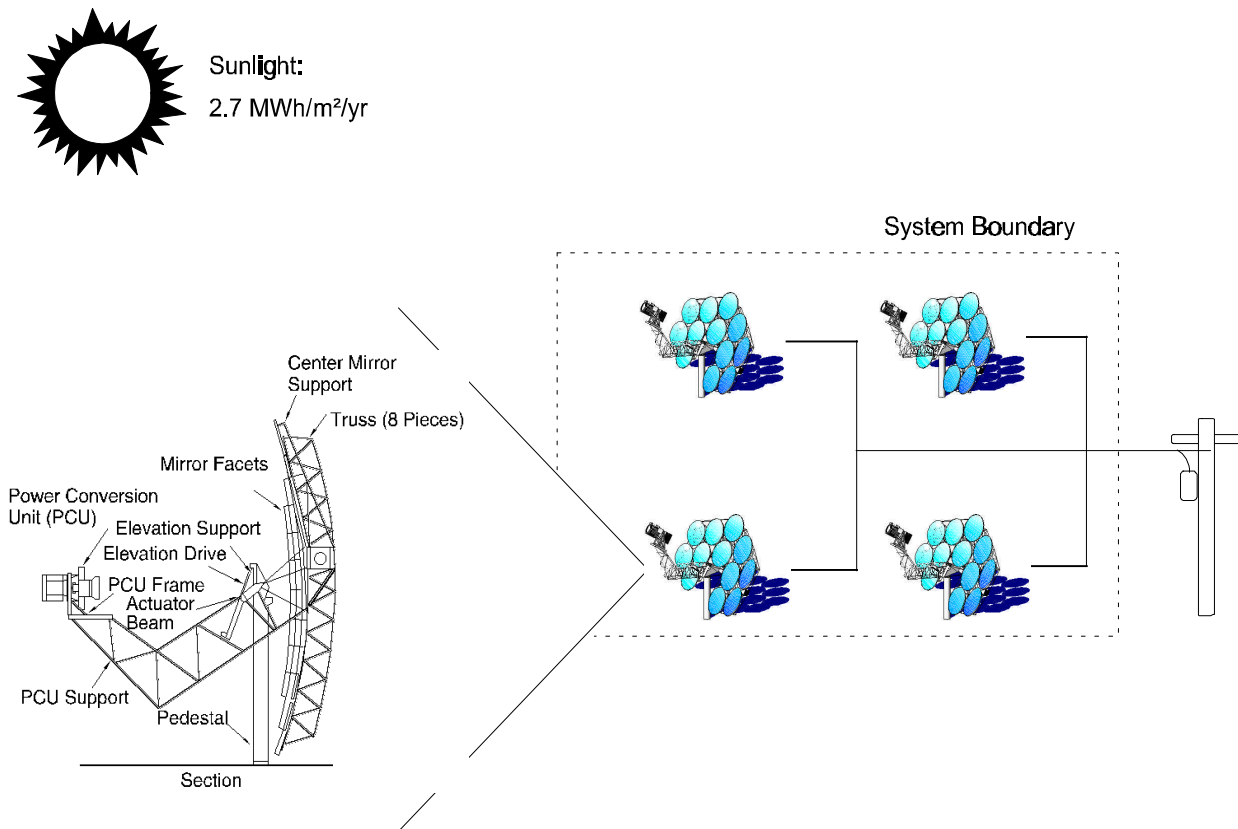

Figure 1. Dish/engine system schematic. The combination of four 25 kW<sub>e</sub> units shown here is representative of a village power application

Dish/engine systems are characterized by high efficiency, modularity, autonomous operation, and an inherent hybrid capability (the ability to operate on either solar energy or a fossil fuel, or both). Of all solar technologies, dish/engine systems have demonstrated the highest solar-to-electric conversion efficiency (29.4%)[1], and therefore have the potential to become one of the least expensive sources of renewable energy. The modularity of dish/engine systems allows them to be deployed individually for remote applications, or grouped together for small-grid (village power) or end-of-line utility applications. Dish/engine systems can also be hybridized with a fossil fuel to provide dispatchable power. This technology is in the engineering development stage and technical challenges remain concerning the solar components and the commercial availability of a solarizable engine. The following describes the components of dish/engine systems, history, and current activities.



## SOLAR DISH ENGINE

### Concentrators

Dish/engine systems utilize concentrating solar collectors that track the sun in two axes. A reflective surface, metalized glass or plastic, reflects incident solar radiation to a small region called the focus. The size of the solar concentrator for dish/engine systems is determined by the engine. At a nominal maximum direct normal solar insolation of  $1000 \text{ W/m}^2$ , a 25-kW<sub>e</sub> dish/Stirling system's concentrator has a diameter of approximately 10 meters.

Concentrators use a reflective surface of aluminum or silver, deposited on glass or plastic. The most durable reflective surfaces have been silver/glass mirrors, similar to decorative mirrors used in the home. Attempts to develop low-cost reflective polymer films have had limited success. Because dish concentrators have short focal lengths, relatively thin-glass mirrors (thickness of approximately 1 mm) are required to accommodate the required curvatures. In addition, glass with a low-iron content is desirable to improve reflectance. Depending on the thickness and iron content, silvered solar mirrors have solar reflectance values in the range of 90 to 94%.

The ideal concentrator shape is a paraboloid of revolution. Some solar concentrators approximate this shape with multiple, spherically-shaped mirrors supported with a truss structure (Figure 1). An innovation in solar concentrator design is the use of stretched-membranes in which a thin reflective membrane is stretched across a rim or hoop. A second membrane is used to close off the space behind. A partial vacuum is drawn in this space, bringing the reflective membrane into an approximately spherical shape. Figure 2 is a schematic of a dish/Stirling system that utilizes this concept. The concentrator's optical design and accuracy determine the concentration ratio. Concentration ratio, defined as the average solar flux through the receiver aperture divided by the ambient direct normal solar insolation, is typically over 2000. Intercept fractions, defined as the fraction of the reflected solar flux that passes through the receiver aperture, are usually over 95%.

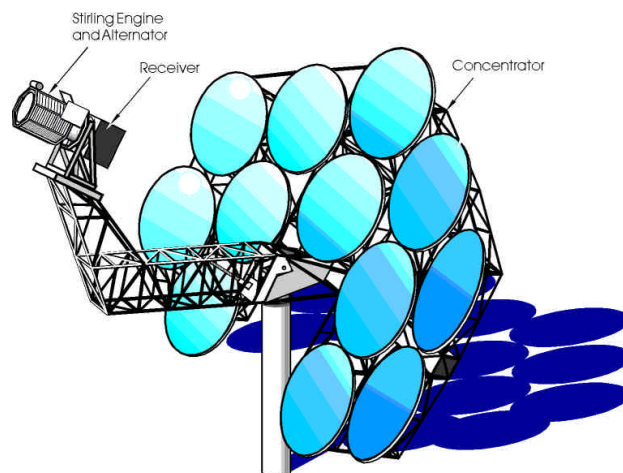

Figure 2. Schematic of a dish/engine system with stretched-membrane mirrors.

Tracking in two axes is accomplished in one of two ways, (1) azimuth-elevation tracking and (2) polar tracking. In azimuth-elevation tracking, the dish rotates in a plane parallel to the earth (azimuth) and in another plane perpendicular to it (elevation). This gives the collector left/right and up/down rotations. Rotational rates vary throughout the day but

## SOLAR DISH ENGINE

can be easily calculated. Most of the larger dish/engine systems use this method of tracking. In the polar tracking method, the collector rotates about an axis parallel to the earth's axis of rotation. The collector rotates at a constant rate of  $15^\circ/\text{hr}$  to match the rotational speed of the earth. The other axis of rotation, the declination axis, is perpendicular to the polar axis. Movement about this axis occurs slowly and varies by  $\pm 23\frac{1}{2}^\circ$  over a year. Most of the smaller dish/engine systems have used this method of tracking.

### Receivers

The receiver absorbs energy reflected by the concentrator and transfers it to the engine's working fluid. The absorbing surface is usually placed behind the focus of the concentrator to reduce the flux intensity incident on it. An aperture is placed at the focus to reduce radiation and convection heat losses. Each engine has its own interface issues. Stirling engine receivers must efficiently transfer concentrated solar energy to a high-pressure oscillating gas, usually helium or hydrogen. In Brayton receivers the flow is steady, but at relatively low pressures.

There are two general types of Stirling receivers, direct-illumination receivers (DIR) and indirect receivers which use an intermediate heat-transfer fluid. Directly-illuminated Stirling receivers adapt the heater tubes of the Stirling engine to absorb the concentrated solar flux. Because of the high heat transfer capability of high-velocity, high-pressure helium or hydrogen, direct-illumination receivers are capable of absorbing high levels of solar flux (approximately  $7.5 \text{ W}/\text{cm}^2$ ). However, balancing the temperatures and heat addition between the cylinders of a multiple cylinder Stirling engine is an integration issue.

Liquid-metal, heat-pipe solar receivers help solve this issue. In a heat-pipe receiver, liquid sodium metal is vaporized on the absorber surface of the receiver and condensed on the Stirling engine's heater tubes (Figure 3). This results in a uniform temperature on the heater tubes, thereby enabling a higher engine working temperature for a given material, and therefore higher engine efficiency. Longer-life receivers and engine heater heads are also theoretically possible by the use of a heat-pipe. The heat-pipe receiver isothermally transfers heat by evaporation of sodium on the receiver/absorber and condensing it on the heater tubes of the engine. The sodium is passively returned to the absorber by gravity and distributed over the absorber by capillary forces in a wick. Receiver technology for Stirling engines is discussed in Diver et al. [2]. Heat-pipe receiver technology has demonstrated significant performance enhancements to an already efficient dish/Stirling power conversion module [3]. Stirling receivers are typically about 90% efficient in transferring energy delivered by the concentrator to the engine.

Solar receivers for dish/Brayton systems are less developed. In addition, the heat transfer coefficients of relatively low-pressure air along with the need to minimize pressure drops in the receiver make receiver design a challenge. The most successful Brayton receivers have used "volumetric absorption" in which the concentrated solar radiation passes through a fused silica "quartz" window and is absorbed by a porous matrix. This approach provides significantly greater heat transfer area than conventional heat exchangers that utilize conduction through a wall. Volumetric Brayton receivers using honeycombs and reticulated open-cell ceramic foam structures that have been successfully demonstrated, but for only short term operation (tens of hours) [4,5]. Test time has been limited by the availability of a Brayton engine. Other designs involving conduction through a wall and the use of fins have also been considered. Brayton receiver efficiency is typically over 80% [4,5].

## SOLAR DISH ENGINE

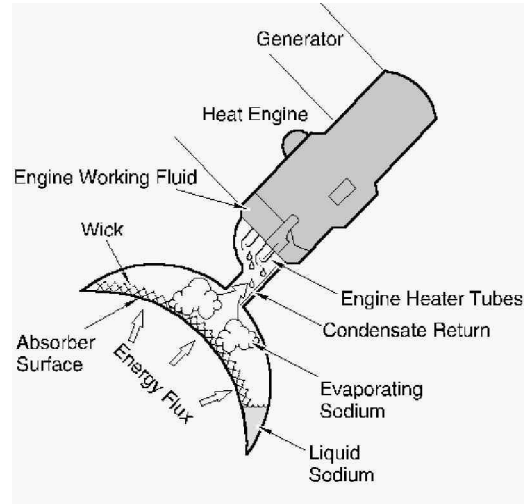

Figure 3. Schematic which shows the operation of a heat-pipe solar receiver.

### Engines

The engine in a dish/engine system converts heat to mechanical power in a manner similar to conventional engines, that is by compressing a working fluid when it is cold, heating the compressed working fluid, and then expanding it through a turbine or with a piston to produce work. The mechanical power is converted to electrical power by an electric generator or alternator. A number of thermodynamic cycles and working fluids have been considered for dish/engine systems. These include Rankine cycles, using water or an organic working fluid; Brayton, both open and closed cycles; and Stirling cycles. Other, more exotic thermodynamic cycles and variations on the above cycles have also been considered. The heat engines that are generally favored use the Stirling and open Brayton (gas turbine) cycles. The use of conventional automotive Otto and Diesel engine cycles is not feasible because of the difficulties in integrating them with concentrated solar energy. Heat can also be supplied by a supplemental gas burner to allow operation during cloudy weather and at night. Electrical output in the current dish/engine prototypes is about 25 kW<sub>e</sub> for dish/Stirling systems and about 30 kW<sub>e</sub> for the Brayton systems under consideration. Smaller 5 to 10 kW<sub>e</sub> dish/Stirling systems have also been demonstrated.

**Stirling Cycle:** Stirling cycle engines used in solar dish/Stirling systems are high-temperature, high-pressure externally heated engines that use a hydrogen or helium working gas. Working gas temperatures of over 700 °C (1292°F) and as high as 20 MPa are used in modern high-performance Stirling engines. In the Stirling cycle, the working gas is alternately heated and cooled by constant-temperature and constant-volume processes. Stirling engines usually incorporate an efficiency-enhancing regenerator that captures heat during constant-volume cooling and replaces it when the gas is heated at constant volume. Figure 4 shows the four basic processes of a Stirling cycle engine. There are a number of mechanical configurations that implement these constant-temperature and constant-volume processes. Most involve the use of pistons and cylinders. Some use a displacer (a piston that displaces the working gas without changing its volume) to shuttle the working gas back and forth from the hot region to the cold region of the engine. For most engine designs, power is extracted kinematically by a rotating crankshaft. An exception is the free-piston configuration, where the pistons are not constrained by crankshafts or other mechanisms. They bounce back and forth on springs and the power is extracted from the power piston by a linear alternator or pump. A number of excellent references are available that describe the principles of Stirling machines. The best of the Stirling engines achieve

## SOLAR DISH ENGINE

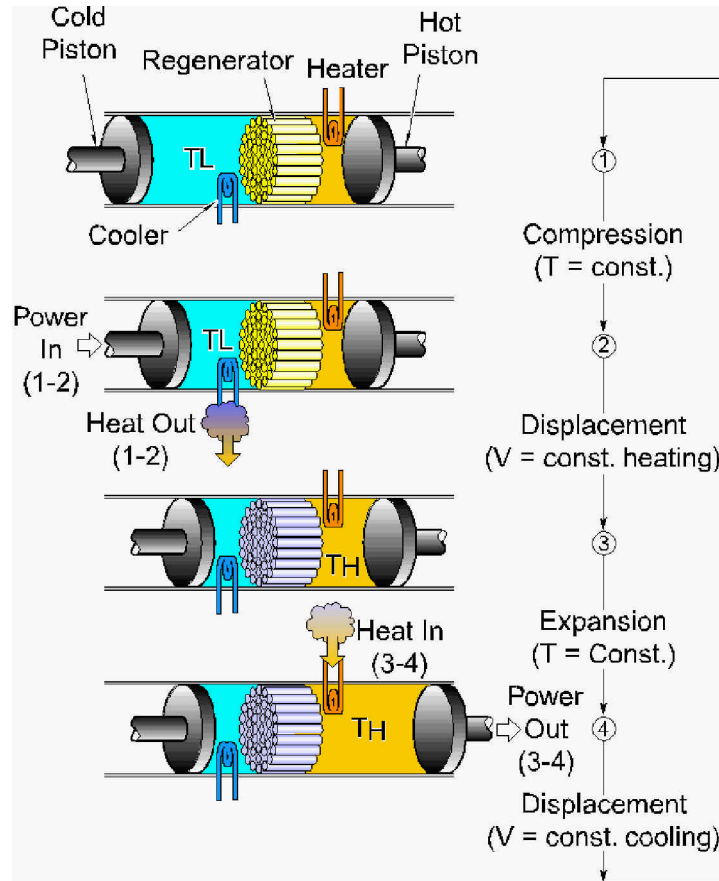

Figure 4. Schematic showing the principle of operation of a Stirling engine.

thermal-to-electric conversion efficiencies of about 40% [6-8]. Stirling engines are a leading candidate for dish/engine systems because their external heating makes them adaptable to concentrated solar flux and because of their high efficiency.

Currently, the contending Stirling engines for dish/engine systems include the SOLO 161 11-kW<sub>e</sub> kinematic Stirling engine, the Kockums (previously United Stirling) 4-95 25-kW<sub>e</sub> kinematic Stirling engine, and the Stirling Thermal Motors STM 4-120 25-kW<sub>e</sub> kinematic Stirling engine. (At present, no free-piston Stirling engines are being developed for dish/engine applications.) All of the kinematic Stirling engines under consideration for solar applications are being built for other applications. Successful commercialization of any of these engines will eliminate a major barrier to the introduction of dish/engine technology. The primary application of the SOLO 161 is for cogeneration in Germany; Kockums is developing a larger version of the 4-95 for submarine propulsion for the Swedish navy; and the STM4-120 is being developed with General Motors for the DOE Partnership for the Next Generation (Hybrid) Vehicle Program.

**Brayton Cycle:** The Brayton engine, also called the jet engine, combustion turbine, or gas turbine, is an internal combustion engine which produces power by the controlled burning of fuel. In the Brayton engine, like in Otto and Diesel cycle engines, air is compressed, fuel is added, and the mixture is burned. In a dish/Brayton system, solar heat is used to replace (or supplement) the fuel. The resulting hot gas expands rapidly and is used to produce power. In the gas turbine, the burning is continuous and the expanding gas is used to turn a turbine and alternator. As in the

## SOLAR DISH ENGINE

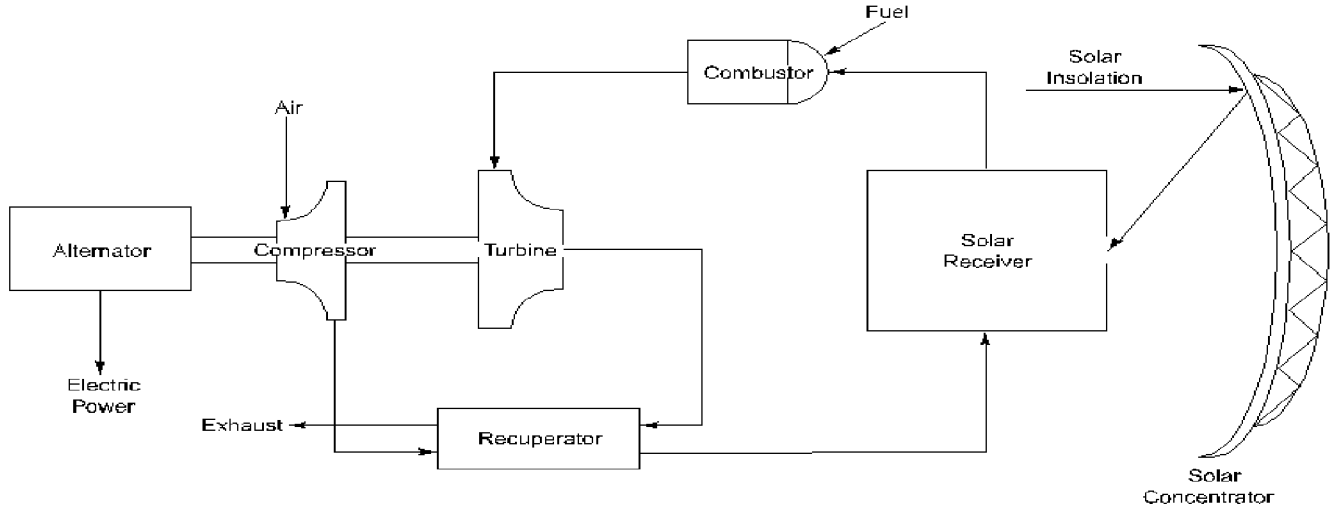

Figure 5. Schematic of a Dish/Brayton system.

Stirling engine, recuperation of waste heat is a key to achieving high efficiency. Therefore, waste heat exhausted from the turbine is used to preheat air from the compressor. A schematic of a single-shaft, solarized, recuperated Brayton engine is shown in Figure 5. The recuperated gas turbine engines that are candidates for solarization have pressure ratios of approximately 2.5, and turbine inlet temperatures of about 850 °C (1,562°F). Predicted thermal-to-electric efficiencies of Brayton engines for dish/Brayton applications are over 30% [9,10].

The commercialization of similar turbo-machinery for various applications by Allied Signal, Williams International, Capstone Turbines Corp., Northern Research and Engineering Company (NREC), and others may create an opportunity for dish/Brayton system developers.

### Ancillary Equipment

**Alternator:** The mechanical-to-electrical conversion device used in dish/engine systems depends on the engine and application. Induction generators are used on kinematic Stirling engines tied to an electric-utility grid. Induction generators synchronize with the grid and can provide single or three-phase power of either 230 or 460 volts. Induction generators are off-the-shelf items and convert mechanical power to electricity with an efficiency of about 94%. Alternators in which the output is conditioned by rectification (conversion to DC) and then inverted to produce AC power are sometimes employed to handle mismatches in speed between the engine output and the electrical grid. The high-speed output of a gas turbine, for example, is converted to very high frequency AC in a high-speed alternator, converted to DC by a rectifier, and then converted to 60 hertz single or three-phase power by an inverter. This approach can also have performance advantages for operation of the engine.

**Cooling System:** Heat engines need to transfer waste heat to the environment. Stirling engines use a radiator to exchange waste heat from the engine to the atmosphere. In open-cycle Brayton engines, most of the waste heat is rejected in the exhaust. Parasitic power required for operation of a Stirling cooling system fan and pump, concentrator drives, and controls is typically about 1 kW<sub>e</sub>.

## SOLAR DISH ENGINE

**Controls:** Autonomous operation is achieved by the use of microcomputer-based controls located on the dish to control dish tracking and engine operation. Some systems use a separate engine controller. For large installations, a central System Control and Data Acquisition (SCADA) computer is used to provide supervisory control, monitoring, and data acquisition.

### History

Dish/engine technology is the oldest of the solar technologies, dating back to the 1800s when a number of companies demonstrated solar powered steam-Rankine and Stirling-based systems. Modern technology was developed in the late 1970s and early 1980s by United Stirling AB, Advanco Corporation, McDonnell Douglas Aerospace Corporation (MDA), NASA's Jet Propulsion Laboratory, and DOE. This technology used directly-illuminated, tubular solar receivers, the United Stirling 4-95 kinematic Stirling engine developed for automotive applications, and silver/glass mirror dishes. A sketch of the United Stirling Power Conversion Unit (PCU), including the directly illuminated receiver, is shown in Figure 6. The Advanco Vanguard system, a 25 kW<sub>e</sub> nominal output module, recorded a record solar-to-electric conversion efficiency of 29.4% (net) using the United Stirling PCU [1,11]. This efficiency is defined as the net electrical power delivered to the grid, taking into account the electrical power needed for parasitics, divided by the direct normal insolation incident on the mirrors. MDA subsequently attempted to commercialize a system using the United Stirling PCU and a dish of their own design. Eight prototype systems were produced by MDA before the program was canceled in 1986 and the rights to the hardware and technology sold to Southern California Edison (SCE). The cancellation of the dish/Stirling program was part of MDA's decision to cancel all of their energy related activities, despite the excellent technical success of their dish/Stirling system. The MDA systems routinely converted sunlight incident on the concentrator's mirrors to electricity with net efficiencies of about 30%. Southern California Edison Company continued to test the MDA system on a daily basis from 1986 through 1988. During its last year of operation,

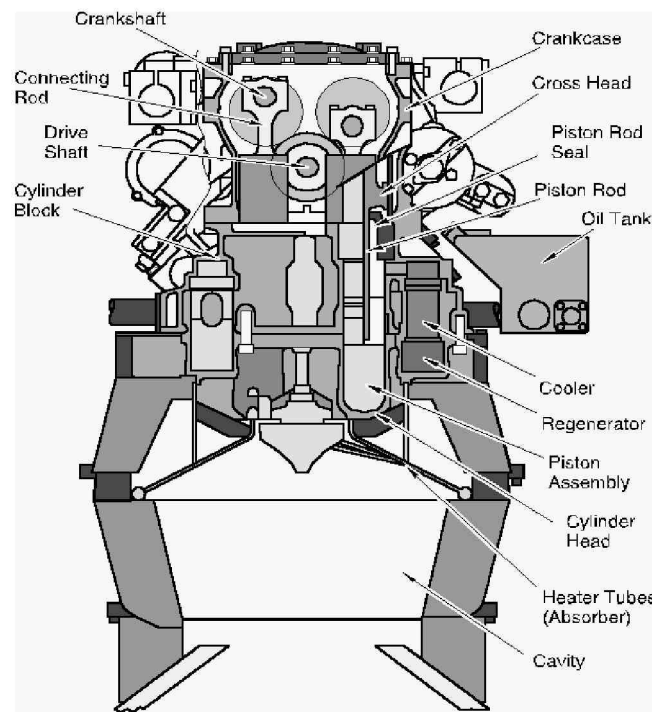

Figure 6. Schematic of the United Stirling 4-95 Kinematic Stirling engine.

## SOLAR DISH ENGINE

it achieved an annual efficiency of about 12%, including system outages and all other effects such as mirror soiling . This is also a record for solar energy systems. Without outages, an annual efficiency of over 23% was determined to be achievable [12-15].

In the early 1990s, Cummins Engine Company attempted to commercialize dish/Stirling systems based on free-piston Stirling engine technology. The Cummins development efforts were supported by SunLab through two 50/50 cost shared contracts. (SunLab is a “virtual” laboratory composed of the solar thermal programs at Sandia National Laboratories and the National Renewable Energy Laboratory.) The Dish/Stirling Joint Venture Program (DSJVP) was started in 1991 and was intended to develop a 5 to 10 kW<sub>e</sub> dish/Stirling system for remote power applications [16]. The Utility Scale Joint Venture Program (USJVP) was started in late 1993 with the goal of developing a 25 kW<sub>e</sub> dish/engine system for utility applications [17]. However, largely because of a corporate decision to focus on its core diesel-engine business, Cummins canceled their solar development in 1996. Technical difficulties with Cummins’ free-piston Stirling engines were never resolved [18].

### Current Activities

In 1993, another USJVP contract was initiated with Science Applications International Corporation (SAIC) and Stirling Thermal Motors (STM) to develop a dish/Stirling system for utility-scale applications. The SAIC/STM team successfully demonstrated a 20-kW<sub>e</sub> unit in Golden, Colorado, in Phase 1. In December 1996, Arizona Public Service Company (APS) partnered with SAIC and STM to build and demonstrate the next five prototype dish/engine systems in the 1997-1998 time frame. SAIC and Stirling Thermal Motors, Inc. (STM) are working on next-generation hardware including a third-generation version of the STM 4-120, a faceted stretched-membrane dish with a face-down-storage capability, and a directly-illuminated hybrid receiver. The overall objective is to reduce costs while maintaining demonstrated performance levels. Phase 3 of the USJVP calls for the deployment of one megawatt of dish/engine systems in a utility environment, which APS could then use to assist in meeting the requirements of Arizona’s renewable portfolio standard.

The economic potential of dish/engine systems continues to interest developers and investors. For example, Stirling Energy Systems (SES) has purchased the rights of the MDA technology, including the rights to manufacture the Kockums 4-95 Stirling engine. SES is working with MDA to revive and improve upon the 1980s vintage system. There is also interest by Allied Signal Aerospace in applying one of their industrial Brayton engine designs to solar power generation. In response to this interest, DOE issued a request for proposal in the spring of 1997 under the Dish Engine Critical Components (DECC) initiative. The DECC initiative is intended to encourage “solarization” of industrial engines and involves major industrial partners.

Next-generation hybrid receiver technology based on sodium heat pipes is being developed by SunLab in collaboration with industrial partners. Although, heat-pipe receiver technology is promising and significant progress has been made, cost-effective designs capable of demonstrating the durability required of a commercial system still need to be proven. SunLab is also developing other solar specific technology in conjunction with industry.

### 2.0 System Application, Benefits, and Impacts

Dish/engine systems have the attributes of high efficiency, versatility, and hybrid operation. High efficiency contributes to high power densities and low cost, compared to other solar technologies. Depending on the system and the site, dish/engine systems require approximately 1.2 to 1.6 ha of land per MW<sub>e</sub>. System installed costs, although currently over \$12,000/kW<sub>e</sub> for solar-only prototypes could approach \$1,400/kW<sub>e</sub> for hybrid systems in mass production (see

## SOLAR DISH ENGINE

Section 4.0). This relatively low-cost potential is, to a large extent, a result of dish/engine system's inherent high efficiency.

### Utility Application

Because of their versatility and hybrid capability, dish/engine systems have a wide range of potential applications. In principle, dish/engine systems are capable of providing power ranging from kilowatts to gigawatts. However, it is expected that dish/engine systems will have their greatest impact in grid-connected applications in the 1 to 50 MW<sub>e</sub> power range. The largest potential market for dish/engine systems is large-scale power plants connected to the utility grid. Their ability to be quickly installed, their inherent modularity, and their minimal environmental impact make them a good candidate for new peaking power installations. The output from many modules can be ganged together to form a dish/engine farm and produce a collective output of virtually any desired amount. In addition, systems can be added as needed to respond to demand increases. Hours of peak output are often coincident with peak demand. Although dish/engine systems do not currently have a cost-effective energy storage system, their ability to operate with fossil or bio-derived fuels makes them, in principal, fully dispatchable. This capability in conjunction with their modularity and relatively benign environmental impacts suggests that grid support benefits could be a major advantage of these systems.

### Remote Application

Dish/engine systems can also be used individually as stand-alone systems for applications such as water pumping. While the power rating and modularity of dish/engine systems seem ideal for stand-alone applications, there are challenges related to installation and maintenance of these systems in a remote environment. Dish/engine systems need to stow when wind speeds exceed a specific condition, usually at about 16 m/s. Reliable sun and wind sensors are therefore required to determine if conditions warrant operation. In addition, to enable operation until the system can become self sustaining, energy storage (e.g., a battery like those used in a diesel generator set) with its associated cost and reliability issues is needed. Therefore, it is likely that significant entry in stand-alone markets will occur after the technology has had an opportunity to mature in utility and village-power markets.

Intermediate-scale applications such as small grids (village power) appear to be well suited to dish/engine systems. The economies of scale of utilizing multiple units to support a small utility, the ability to add modules as needed, and a hybrid capability make the dish/engine systems ideal for small grids.

### Hybridization

Because dish/engine systems use heat engines, they have an inherent ability to operate on fossil fuels. The use of the same power conversion equipment, including the engine, generator, wiring, switch gear, etc., means that only the addition of a fossil fuel combustor is required to enable a hybrid capability. For dish/Brayton systems, addition of a hybrid capability is straightforward. A fossil-fuel combustor capable of providing continuous full-power operation can be provided with minimal expense or complication. The hybrid combustor is downstream of the solar receiver, Figure 5, and has virtually no adverse impact on performance. In fact, because the gas turbine engine can operate continuously at its design point, where efficiency is optimum, overall system efficiency is enhanced. System efficiency, based on the higher heating value, is expected to be about 30% for a dish/Brayton system operating in the hybrid mode.

For dish/Stirling systems, on the other hand, addition of a hybrid capability is a challenge. The external, high-temperature, isothermal heat addition required for Stirling engines is in many ways easier to integrate with solar heat than it is with the heat of combustion. Geometrical constraints makes simultaneous integration even more difficult. As a result, costs for Stirling hybrid capability are expected to be on the order of an additional \$250/kW<sub>e</sub> in large scale



## SOLAR DISH ENGINE

production. These costs are less than the addition of a separate diesel generator set, for a small village application, or a gas turbine for a large utility application. To simplify the integration of the two heat input sources, the first SAIC/STM hybrid dish/Stirling systems will operate on solar or gas, but not both at the same time. Although, the cost of these systems is expected to be much less than a continuously variable hybrid receiver, their operational flexibility will be substantially reduced. System efficiency, based on higher heating value, is expected to be about 33% for a dish/Stirling system operating in the hybrid mode.

### Environmental Impacts

The environmental impacts of dish/engine systems are minimal. Stirling engines are known for being quiet, relative to internal combustion gasoline and diesel engines, and even the highly recuperated Brayton engines are reported to be relatively quiet. The biggest source of noise from a dish/Stirling system is the cooling fan for the radiator. There has not been enough deployment of dish/engine systems to realistically assess visual impact. The systems can be high profile, extending as much as 15 meters above the ground. However, aesthetically speaking they should not be considered detrimental. Dish/engine systems resemble satellite dishes which are generally accepted by the public. Emissions from dish/engine systems are also quite low. Other than the potential for spilling small amounts of engine oil or coolant or gearbox grease, these systems produce no effluent when operating with solar energy. Even when operating with a fossil fuel, the steady flow combustion systems used in both Stirling and Brayton systems result in extremely low emission levels. This is, in fact, a requirement for the hybrid vehicle and cogeneration applications for which these engines are primarily being developed.

### 3.0 Technology Assumptions and Issues

Dish/engine systems are not now commercially available, except as engineering prototypes. The base year (1997) technology is represented by the 25 kW<sub>e</sub> dish-Stirling system developed by McDonnell Douglas Aerospace (MDA) in the mid 1980's using either an upgraded Kockums 4-95 or a STM 4-120 kinematic Stirling engine. The MDA system is similar in projected cost to the Science Applications International Corporation/Stirling Thermal Motors (SAIC/STM) dish/Stirling system, but has been better characterized. The SAIC/STM system is expected to have a peak net system efficiency of 21.9%. The SAIC/STM system uses stretched-membrane mirror modules that result in a lower intercept fraction and a higher receiver loss than the MDA system. However, the lower-cost stretched-membrane design and its improved operational flexibility are projected by SAIC to produce comparably priced systems [19].

Solar thermal dish/engine technologies are still considered to be in the engineering development stage. Assuming the success of current dish/engine joint ventures, these systems could become commercially available in the next 2 to 4 years. The base-year system consists of a dish concentrator that employs silver/glass mirror panels. The receiver is a directly-illuminated tubular receiver. As a result of extensive engineering development on the STM 4-120 and the Kockums engines, near-term technologies (year 2000 and 2005) are expected to achieve significant availability improvements for the engine, thus nearly doubling annual efficiency over the base year technology (from 12 to 23 %). For the years 2010 and on, systems are anticipated to benefit from evolutionary advances in dish concentrator and engine technology. For this analysis, a 10% improvement, compared to the base-year system, is assumed based on the introduction of heat-pipe receiver technology. The introduction of advanced materials and/or the incorporation of ceramics or volumetric absorption concepts could provide significant advances in performance compared to the baseline. Favorable development of advanced concepts could result in improvements of more than an additional 10%. However, because there are no significant activities in these areas, they are not included in this analysis.

## SOLAR DISH ENGINE

The system characterized is located in a region of high direct normal insolation ( $2.7 \text{ MWh/m}^2/\text{yr}$ ), which is typified by the Mojave Desert of Southern California. Insolation is consistent with desert regions throughout the Southwest United States.

### Research and Development Needs

The introduction of a commercial solar engine is the primary research and development (R&D) need for dish/engine technology. Secondary R&D needs include a commercially viable heat-pipe solar receiver for dish/Stirling, a hybrid receiver design for dish/Stirling, and a proven receiver for dish/Brayton. All three of these issues are currently being addressed by SunLab and its partners, as part of the DOE Solar Thermal Electric Program. In addition, improvement in dish concentrator components, specifically drives, optical elements, and structures, are still needed and are also being addressed, albeit at a low level of effort. The solar components are the high cost elements of a dish engine system, and improved designs, materials, characterization, and manufacturing techniques are key to improving competitiveness.

Systems integration and product development are issues for any new product. For example, even though MDA successfully resolved many issues for their system, their methods may not apply or may not be available to other designs. Issues such as installation logistics, control algorithms, facet manufacturing, mirror characterization, and alignment methods, although relatively pedestrian, still need resolution for any design. Furthermore, if not addressed correctly, they can adversely affect cost. An important function of the Joint Ventures between SunLab and industry is to address these issues.

### Advanced Development Opportunities

Beyond the R&D required to facilitate commercialization of the industrial derivative engines discussed above, there are high-payoff opportunities for engines designed exclusively for solar applications. The Advanced Stirling Conversion System (ASCS) program administered by the National Aeronautics and Space Administration (NASA) Lewis Research Center for DOE between 1986 and 1992, with the purpose of developing a high-performance free-piston Stirling engine/linear alternator, is an example of a high-risk high-payoff development [20]. An objective of the ASCS was to exploit the long life and reliability potential of free-piston Stirling engines.

Thermodynamically, solar thermal energy is an ideal match to Stirling engines because it can efficiently provide energy isothermally at high temperatures. In addition, the use of high-temperature ceramics or the development of "volumetric" Stirling receiver designs, in which a unique characteristic of concentrated solar flux is exploited, are other high-payoff R&D opportunities. Volumetric receivers exploit a characteristic of solar energy by avoiding the inherent heat transfer problems associated with conduction of high-temperature heat through a pressure vessel. Volumetric receivers avoid this by transmitting solar flux through a fused silica "quartz" window as light and can potentially work at significantly higher temperatures, with vastly extended heat transfer areas, and reduced engine dead volumes, while utilizing a small fraction of the expensive high-temperature alloys required in current Stirling engines. Scoping studies suggest that annual solar-to-electric conversion efficiencies in excess of 30% could be practically achieved with potentially lower cost "volumetric Stirling" designs. Similar performance enhancements can also be obtained by the use of high-temperature ceramic components.

## SOLAR DISH ENGINE

### 4.0 Performance and Cost

Table 1 summarizes the performance and cost indicators for the solar dish/engine system being characterized here.

#### 4.1 Evolution Overview

Over the next 5 to 10 years, only evolutionary advances are expected. The economic viability of dish/engine technology will be greatly enhanced if an engine capable of being “solarized” (i.e., integrated with solar energy) is introduced for another application. The best candidates are the STM 4-120 and the Kockums 4-95 kinematic Stirling engines for hybrid vehicles and industrial generators, and the industrial gas turbine/generators. Assuming one of these engines becomes commercial, then commercialization of dish/engine systems at some level becomes likely. With the costs and risks of the critical power conversion unit significantly reduced, only the concentrator, receiver, and controls would remain as issues. Given the operational experience and demonstrated durability and reliability of the remaining solar components, as well as the cost and performance capabilities of dish/engine technology, commercialization may appear attractive to some developers and investors. The modularity of dish/engine systems will help facilitate their introduction. Developers can evaluate prototype systems without the risks associated with multi-megawatt installations.

The commercialization of power towers and, therefore, heliostats (constructed of shared solar components), along with the introduction of a solarizable engine, would essentially guarantee a sizable and robust dish/engine industry. The added manufacturing volumes provided by such a scenario for the related concentrator drives, mirror, structural, and control components would significantly reduce costs and provide an attractive low-cost solar product that will compete in the 25 kW<sub>e</sub> to 50 MW<sub>e</sub> power market.

#### 4.2 Performance and Cost Discussion

From the above discussion, one of three basic scenarios will happen: (1) no solarizable engine will be commercialized and, therefore, significant commercialization is unlikely, (2) a solarizable engine will be introduced, therefore spawning a fledgling dish/engine business or industry, and (3) a solarizable engine will be introduced and power tower projects will be initiated. Under this scenario, a large and robust solar dish/engine industry will transpire. Of course, numerous variations on the above scenarios are possible but are impossible to predict, much less consider. For the purpose of this analysis, the second scenario is assumed. The cost and performance data in the table reflect this scenario. As discussed in Section 3.0, a STM 4-120 or Kockums 4-95 is assumed to become commercial by 2000, with a dish/engine industry benefiting from mass production. This scenario is consistent with the commercialization plans of General Motors and STM for the STM 4-120.

Although a Brayton engine for industrial generator sets is also a potential positive development, the table considers a dish/Stirling system. A hybrid capability has been included in the table for the year 2000 and beyond. A capacity factor of 50% is assumed. This corresponds to a solar fraction of 50%.

The following paragraphs provide the basis for the cost and performance numbers in the table. System and component costs are from industry sources and independent SunLab analyses. Costs for the MDA system are from [15]. The installed costs include the cost of manufacturing the concentrator and power conversion unit (PCU), shipment to the site, site preparation, installation of the concentrator and PCU, balance of plant (connection to utility grid). The component costs include a 30% profit. These costs are similar to those projected by SAIC at the same

Table 1. Performance and cost indicators.

INDICATOR NAME	UNITS	1980's Prototype		Hybrid System		Commercial Engine		Heat Pipe Receiver		Higher Production		Higher Production	
		1997	+/-%	2000	+/-%	2005	+/-%	2010	+/-%	2020	+/-%	2030	+/-%
Typical Plant Size, MW	MW	0.025		1	50	30	50	30	50	30	50	30	50
Performance													
Capacity Factor	%	12.4		50.0		50.0		50.0		50.0		50.0	
Solar Fraction	%	100		50		50		50		50		50	
Dish module rating	kW	25.0		25.0		25.0		27.5		27.5		27.5	
Per Dish Power Production	MWh/yr/dish	27.4		109.6		109.6		120.6		120.6		120.6	
Capital Cost													
Concentrator	\$/kW	4,200	15	2,800	15	1,550	15	500	15	400	15	300	15
Receiver		200	15	120	15	80	15	90	15	80	15	70	15
Hybrid		----		500	30	400	30	325	30	270	30	250	30
Engine		5,500	15	800	20	260	25	100	25	90	25	90	25
Generator		60	15	50	15	45	15	40	15	40	15	40	15
Cooling System		70	15	65	15	40	15	30	15	30	15	30	15
Electrical		50	15	45	15	35	15	25	15	25	15	25	15
Balance of Plant		500	15	425	15	300	15	250	15	240	15	240	15
Subtotal (A)		10,580		4,805		2,710		1,360		1,175		1,045	
General Plant Facilities (B)		220	15	190	15	150	15	125	15	110	15	110	15
Engineering Fee, 0.1*(A+B)		1,080		500		286		149		128		115	
Project /Process Contingency		0		0		0		0		0		0	
Total Plant Cost		11,880		5,495		3,146		1,634		1,413		1,270	
Prepaid Royalties		0		0		0		0		0		0	
Init Cat & Chem. Inventory		120	15	60	15	12	15	6	15	6	15	6	15
Startup Costs		350	15	70	15	35	15	20	15	18	15	18	15
Other		0		0		0		0		0		0	
Inventory Capital		200	15	40	15	12	15	4	15	4	15	4	15
Land, @\$16,250/ha		26		26		26		26		26		26	
Subtotal		696		196		85		56		54		54	
Total Capital Requirement		12,576		5,691		3,231		1,690		1,467		1,324	
Total Capital Req. w/o Hybrid		12,576		5,191		2,831		1,365		1,197		1,074	
Operation and Maintenance Cost													
Labor	¢/kWh	12.00	15	2.10	25	1.20	25	0.60	25	0.55	25	0.55	25
Material	¢/kWh	9.00	15	1.60	25	1.10	25	0.50	25	0.50	25	0.50	25
Total	¢/kWh	21.00		3.70		2.30		1.10		1.05		1.05	

Notes:

1. The columns for "+/-%" refer to the uncertainty associated with a given estimate.
2. The construction period is assumed to be <1year for a MW scale system.

## SOLAR DISH ENGINE

production rates [19]. These projections are also consistent with similar estimates by Cummins and with projections by SunLab engineers. Because of the proprietary nature of cost information, detailed breakdowns of cost estimates are not available in the public domain. Costs are also extremely sensitive to production rates. The installed costs are, therefore, extremely dependent on the market penetration actually achieved. Operation and Maintenance (O&M) costs are also based on [15]. They take into account realistic reliability estimates for the individual components. They are also reasonably consistent with O&M for the Luz trough plants and large wind farms. Component costs are a strong function of production rates. Production rate assumptions are also provided. The economic life of a dish/engine power plant is 30 years. The construction period is much less than one year.

### 1997 Technology

The base-year technology (1997) is represented by the 25 kW<sub>e</sub> dish-Stirling system developed by McDonnell Douglas (MDA) in the mid 1980s. Similar cost estimates have been predicted for the Science Applications International Corporation (SAIC) system with the STM 4-120 Stirling engine [19]. Southern California Edison Company operated a MDA system on a daily basis from 1986 through 1988. During its last year of operation, it achieved an annual efficiency of 12% despite significant unavailability caused by spare part delivery delays. This annual efficiency is better than what has been achieved by all other solar electric systems, including photovoltaics, solar thermal troughs, and power towers, operating anywhere in the world [13,21]. The base-year peak and daily performance of near-term technology are assumed to be that of the MDA systems. System costs assume construction of eight units. Operation and maintenance (O&M) costs are of the prototype demonstration and accordingly reflect the problems experienced.

### 2000 Technology

Near-term systems (2000) are expected to achieve significant availability improvements resulting in an annual efficiency of 23%. The MDA system consistently achieved daily solar efficiencies in excess of 23% when it was operational. The low availability achieved with the base-year technology was primarily caused by delays in receiving spare parts and by the lack of a dedicated O&M staff. A 23% annual efficiency is, therefore, a reasonable expectation, assuming Stirling engines are commercialized for other applications, and spare parts and a dedicated staff are available. In addition, near term technologies should see a modest reduction in the cost of the dish concentrator simply as a result of the benefits of an additional design iteration. Prototypes for these near-term technologies were first demonstrated in 1985 by McDonnell Douglas and United Stirling. Similar operational behavior was demonstrated in 1995 by SAIC and STM, although for a shorter test period and a lower system efficiency. O&M costs reflect improvements in reliability expected with the introduction of a commercial engine. Production of 100 modules is assumed. At this production rate, component costs are high, resulting in installed costs of nearly \$5,700/kW<sub>e</sub>.

### 2005 Technology

Performance for 2005 is largely based on one of the solarizable engines being commercialized for a non-solar application (e.g., GM's introduction of the STM 4-120 Stirling engine for use in hybrid vehicles). Use of a production-level engine will have a significant impact on engine cost as well as overall system cost. This milestone will help trigger a fledgling dish/engine industry. A production rate of 2,000 modules per year is assumed. Achieving a high production rate is key to reducing component costs, especially for the solar concentrator.

## SOLAR DISH ENGINE

### 2010 Technology

Performance for years 2010 and beyond is based on the introduction of the heat-pipe solar receiver. Heat-pipe solar receiver development is currently being supported by SunLab in collaboration with industrial partners. The use of a heat-pipe receiver has already demonstrated performance improvements of well over 10% for the STM 4-120 compared to a direct-illumination receiver [1]. While additional improvements in mirror, receiver, and/or engine technology are not unreasonable expectations, they have not been included. This is, therefore, a conservative scenario. A production rate of 30,000 modules per year is assumed.

By 2010 dish/engine technology is assumed to be approaching maturity. A typical plant may include several hundred to over a thousand systems. It is envisioned that a city located in the U.S. Southwest would have several 1 to 50 MW<sub>e</sub> installations located primarily in its suburbs. A central distribution and support facility could service many installations. In the table, a typical plant is assumed to be 30 MW<sub>e</sub>.

### 2020-2030 Technology

Production levels for 2020 and 2030 are 50,000 and 60,000 modules per year, respectively. No major advances beyond the introduction of heat pipes in the 2010 time frame are assumed for 2020-2030. However, evolutionary improvements in mirror, receiver, and/or engine designs have been assumed. This is a reasonable assumption for a \$2 billion/year, dish/engine industry, especially one leveraged by a larger automotive industry. The system costs are therefore 20 to 25% less than projected by MDA and SAIC at the assumed production levels. The MDA and SAIC estimates are for their current designs and do not include the benefits of a heat-pipe receiver. In addition, the MDA engine costs are for an engine that is being manufactured primarily for solar applications. Advanced concepts (e.g., volumetric Stirling receivers) and/or materials, which could improve annual efficiency by an additional 10%, have not been included in the cost projections. With these improvements installed costs of less than \$1,000/kW<sub>e</sub> are not unrealistic.

## 5.0 Land, Water and Critical Materials Requirements

Land requirements for dish/engine systems are approximately 1.2-1.6 ha/MW<sub>e</sub>. No water is required for engine cooling. In some locations, a minimal amount of water is required for mirror washing. There are no key materials that are unique to dish/engine technology.

## 6.0 References

1. Washom, B., "Parabolic Dish Stirling Module Development and Test Results," Paper No. 849516, Proceedings of the IECEC, San Francisco, CA (1984).
2. Diver, R.B., C.E. Andraka, J.B. Moreno, D.R. Adkins, and T.A. Moss, "Trends in Dish-Stirling Solar Receiver Design," Proceedings of the IECEC, Reno, NV (1990).
3. Andraka, C.E., et. al., "Solar Heat Pipe Testing of the Stirling Thermal Motors 4-120 Stirling Engine," Paper No. 96306, Proceedings of the IECEC, Washington, D.C. (1996).
4. Sanders Associates, Parabolic Dish Module Experiment, Final Report, Sandia National Laboratories, Albuquerque, NM: 1986. Report SAND85-7007.

## SOLAR DISH ENGINE

5. Buck, R., P. Heller, and H. Koch, "Receiver Development for a Dish-Brayton System," Proceedings of the 1996 ASME International Solar Energy Conference, San Antonio, TX (1996).
6. Stine, W.B. and R.P. Diver, *A Compendium of Solar Dish/Stirling Technology*, Sandia National Laboratories, Albuquerque, NM: 1994. Report SAND93-7026 UC-236
7. West, C.D., *Principles and Applications of Stirling Engines*, Van Nostrand Reinhold Company, New York, NY, 1986.
8. Walker, G., *Stirling Engines*, Clarendon Press, Oxford, England, 1980.
9. Weinstein, C.H., "Allied Signal Turbogenerators," Allied Signal Aerospace Equipment Systems Brochure, Torrance CA.
10. Gallup, D.R. and Kesseli, J.B., "A Solarized Brayton Engine Based on Turbo-Charger Technology and the DLR Receiver," Proceedings of the IECEC, AIAA-94-3945-CP, Monterey, CA. (1994).
11. Droher, J.J., and Squier, Performance of the Vanguard Solar Dish-Stirling Engine Module, Electric Power Research Institute, Palo Alto, CA: 1986. Report AP-4608.
12. Lopez, C.W., and K.W. Stone, "Design and Performance of the Southern California Edison Stirling Dish," Proceedings of the 1992 ASME-JSES-KSES International Solar Energy Conference, Maui, HI (1992).
13. Lopez, C.W., and K.W. Stone, Performance of the Southern California Edison Company Stirling Dish, Sandia National Laboratories, Albuquerque, NM: 1993. Report SAND93-7098.
14. Stone, K.W., and R.E. Drubka, "Impact of Stirling Engine Operational Requirements on Dish-Stirling System Life Cycle Costs," Proceedings of the 1994 ASME Solar Energy Conference, San Francisco, CA (1994).
15. Stone, K.W., C.W. Lopez, and R. McAlister, "Economic Performance of the SCE Stirling Dish, Proceedings of the IECEC, Atlanta, Georgia (1993).
16. Bean, J.R., and R.B. Diver, "The CPG 5-kWe Dish/Stirling Development Program," Paper No. 929181, Proceedings of the IECEC, San Diego, CA (1992).
17. Gallup, D.R., T.R. Mancini, J. Christensen, and K. Beninga, "The Utility Scale Joint-Venture Program," Proceedings of the IECEC, AIAA-94-3945-CP, Monterey, CA (1994).
18. Bean, J.R., and R.B. Diver, "Technical Status of the Dish/Stirling Joint Venture Program," Paper No. 95-202, Proceedings of the IECEC, Orlando, FL (1995).
19. Beninga, K, et. al., "Performance Results for the SAIC/STM Prototype Dish/Stirling System," Proceedings of the 1997 ASME International Solar Energy Conference, Washington, D.C. (1997).
20. Shaltens, R.K., and J.G. Schreiber, "Comparison of Conceptual Designs for 25 kWe Advanced Stirling Conversions Systems for Dish Electric Applications," Paper No. 899547, Proceedings of the IECEC, Washington, D.C. (1989).

## **SOLAR DISH ENGINE**

21. Kolb, G.J., "Evaluation of Power Production from the Solar Electric Generating Systems at Kramer Junction: 1988 to 1993," Solar Engineering 1995, Proceedings of the ASME Solar Energy Conference, Maui, HI (1995).



# OVERVIEW OF WIND TECHNOLOGIES

## Introduction

The objective of this Technology Characterization (TC) is to summarize the likely cost and performance improvements in wind technology used for a domestic large windfarm application. Major improvements in cost and performance of wind turbines are likely in the future. Considerable operating experience has been gained over the last 15 years from domestic windfarms, primarily in California but also in Minnesota, Hawaii, Texas, and Vermont. Advances have been made in the ability to design, site, install, operate, and maintain turbines, both on a single-unit level as well as part of an entire windfarm. These improvements are the result of work in manufacturing facilities, windfarms, and research laboratories, and are due to improved manufacturing methods, operating experience, and government and industry research and development. The performance and cost improvements achieved by the industry are the prime reasons for current market acceptance on a limited basis. Still, uncertainty exists in the minds of many would-be investors and utilities, and private developers have indicated that their projects include a cost premium that reflects a perceived higher risk compared to more mature generation technologies.

## Technology Assumptions

The turbines characterized in this document are a composite of several different designs, each of which represents a technology likely to be purchased by users at the present time or in the future. For example, the 1997 technology description is most highly influenced by the 3-bladed, rigid hub, relatively heavy designs of European origin which have been typical in the 1990s. These include the Zond 550 series, and several commercial European turbines. The 1997 description also incorporates the lightweight, more flexible U.S. designs, which have been under development by manufacturers, some in conjunction with the DOE Near-Term Product Improvement Project. Such technology is best represented by three machines: the AWT-26/27, the North Wind 250, and the Cannon Wind Eagle 300. The year 2000 description is a composite drawing heavily from the current DOE Innovative Subsystem Project, and from conceptual design studies and preliminary prototype design plans developed under DOE's Next Generation Turbine Development (NGTD) Project. It assumes a variable speed generator, larger rotor and advanced airfoils, higher hub heights and advanced control systems. The 2005 technology is a projection of trends as envisioned by R&D investigations of advanced components and by analyses conducted under the DOE Wind Energy Program.

From a technology development perspective, the specific technology characteristics for each time period in this document are less important than the trend. The marketplace determines preferred technologies and designs as well as pricing strategies. European designers are as aware as U.S. designers of the design tradeoffs and opportunities for cost and performance improvement. Major government-sponsored advanced turbine development programs are underway in Europe. Often, European designs are larger (in the MW range) than corresponding U.S. designs. This appears to be due to the choice of the designer and the scarcity of European sites with good wind resources. Private sector-developed turbines in Europe are often in the 500 to 750 kW range described for 1997 and 2000 in this Technology Characterization. This TC does not project that all new wind turbines in 2005 will suddenly be a size of one megawatt. Some will be larger; some smaller. Rather, the TC projects a trend toward larger rotors, and higher hub heights and rated power. The choice of these parameters is up to the designer and the marketplace. Economies of scale, manufacturing volume and maintenance all interact. The trend in the United States has been to make design changes in increments and to gather experience with one size before scaling up. That trend is expected to continue.

Finally, this TC will describe cost and performance for relatively large 25 to 50 MW<sub>e</sub> wind farms. An alternative is "clusters," which are typically sized at less than 10 MW<sub>e</sub>. Several such installations have been built recently or are being developed in the U.S. under DOE's Turbine Verification Program in Iowa, Nebraska, New York, Oklahoma, Texas, and Vermont. Cluster plants may have somewhat higher installation costs and O&M expenses than shown here. Another option is small-sized (10 to 150 kW) turbines, which can be sited either individually or grouped, for rural or

## OVERVIEW OF WIND TECHNOLOGIES

village power applications. Such plants also show different construction and O&M expense than described here. TCs for these two other wind plant types may be developed in the next few years.

### Utility Integration Issues

In the near-future, it is likely that wind energy's primary market will be niches that recognize values in addition to cost. Nonetheless, the primary economic product from wind energy is electricity, and as such, a primary market is the electric power generation industry. Barring large policy changes, such as a carbon tax, the principal value of wind energy as an electric generator, without storage facilities, is as a fuel saver. That is, wind energy generation must be used when it is available, thereby displacing energy (and variable operating expenses) that would have otherwise been provided by conventional generation. Because of its intermittent nature, any additional value of wind-generated electricity beyond fuel savings and variable operating expenses will vary depending on (1) site-specific characteristics of the wind resource, and (2) utility load and other characteristics of the electric distribution system. For instance, the ability to site windpower closer to the end user (a "distributed" application) may increase its value to the utility.

Statistically, a windfarm can displace a fraction of the capital cost of some new conventional plant. The critical question, which depends on the correlation of the wind resource with utility demand, is: "How much capacity does a windfarm displace and how much is it worth?" This analytical issue is often termed the capacity credit issue, and can be characterized as firm, dispatchable capacity vs. any as-delevered capacity. Although capacity credit for wind energy is often not accepted by electric utilities, research by NREL [1], Grubb and Halberg in Europe, [2,3], and Henry Kelley at the Office of Technology Assessment suggests that virtually any wind installation merits a capacity credit. As an alternative, hybrid wind/gas or wind/storage systems could earn full capacity credit.

The annual energy generated from the wind can be estimated with some certainty, on a long-term basis. In addition, some locations can have a degree of predictability on a daily or hourly basis. These include islands with trade winds or sites such as the California passes, where winds are caused by the predictable inrush of cooler coastal air as the mountain desert air is warmed and rises. Thus, it is possible for windfarms to get some capacity credit in these locations. Based on these examples, utility operation and wind valuation are affected by wind forecasting ability. Researchers in wind prediction are now beginning to explore techniques which would allow the utility dispatcher to gauge the availability of his wind power plant over the next 6 to 36 hours. In the future, the ability to predict winds on relatively longer time scales will improve, potentially allowing windfarms to be operated with greater certainty, thereby increasing their value. Due to the regional variations in the amount and levels of the wind power resource, and to the other regional variations determining the competitive market for power generation, wind technology will achieve different levels of regional market penetration.

Analysts often quote penetration limits for wind capacity of 5 to 20 percent of installed conventional capacity [4]. This is based on a combination of longer-term system integration limits, such as those discussed above, and system operational limits on the second-to-hour time scale, such as generation control, load following, unit commitment, reserve requirement, and system voltage regulation. A recent study by NREL indicates that hardware and system design advances can address most of the technical concerns resulting from interfacing intermittent renewable generation technologies with the electric system [5]. U.S. studies have shown that a 5 percent penetration level has virtually no effect on system operations, while estimates of the impact of larger numbers appear to be largely speculative. Other work by Grubb and Halberg [2,3] in Europe confirmed that no absolute physical limit exists to the fraction of wind penetration on a large power system. Rather, with increasing penetration, the fuel and capacity savings begin to decrease, so that the system limits are economic rather than physical. Regardless, as Grubb points out, the penetration of wind energy in the U.S. must be much larger before its value begins to degrade in the electric system.

## OVERVIEW OF WIND TECHNOLOGIES

### Resource/Land Use

Wind energy resources are widespread in the continental U.S., Hawaii, and Alaska. The wind resource is very large with an accessible resource base of nearly 88 Quadrillion BTU, from sites with average wind speeds above 5.6 m/s (12.5 mph) at a 10 meter height [6]. Table 1 shows how energy production varies by wind class, and illustrates the critical relationship of the wind speed to electricity production (Power in the wind increases as the cube of the wind speed. Because of operational constraints, electricity production increases approximately as the square of the average wind speed). As Figure 1 shows, good wind resources are available in most regions of the country, with only the Southeast and East Central regions without significant resources [7]. A broad area in the U.S., including the region known as the "Great Plains" contains a large amount of wind in the lower-to-moderate power-class ranges (classes 4 and 5, corresponding to 5.6-6.4 m/s average annual wind speeds at 10 meter height). This area reaches from Montana east to western Minnesota and south to Texas. In any region, however, specific locations can benefit from local terrain features that enhance air flow by channeling it through smaller areas, thus increasing its velocity and resulting power density.

Table 1. Comparison of wind resource classes.

	Avg. Wind Speed Range (m/s @ 10 m)	Wind Power Density Range (W/m <sup>2</sup> at 10 m)	Avg. Wind Speed Range (m/s at 30 m)	Wind Power Density Range (W/m <sup>2</sup> at 30 m)	Electricity Production (Gwh/yr)*
Class 4	5.6-6.0	200-250	6.5-7.0	320-400	1.14
Class 5	6.0-6.4	250-300	7.0-7.4	400-480	1.37
Class 6	6.4-7.0	300-400	7.4-8.2	480-640	1.56

\* Based on 1997 technology, 98% availability, 17.5% losses for class 4, 12.5% losses for class 5 and 6, and calculated at the median wind speed. Section 4 discusses loss assumptions in detail.

The wind resource generally becomes stronger as one moves higher above the ground. Thus, the same resource class has a higher potential for producing energy at 30 meters above ground (typical of today's turbines) than at 10 meters. This effect is called vertical shear. The influence of wind shear is illustrated in Table 1 by comparing the wind power density at 10 m and 30 m. While the higher power classes potentially produce more electricity, a turbine must be designed to withstand the higher turbulence and gusts. Turbine designers tailor turbines for conditions such as a specific wind resource class, hub height, turbulence level, and maximum gust level. A successful turbine design for a high wind power class also must be rugged enough to withstand the environment. For example, in California, the Altamont Pass wind regime is relatively benign, while areas of the Tehachapi Pass are known to experience 45 m/s winds during storms which can damage even a parked turbine if it is not designed for these extreme wind conditions. Obviously, design requirements and tradeoffs affect both the lifetime of a turbine and its costs.

Another key tradeoff for the windfarm developer or operator is transmission access, cost and availability. Developers in the Altamont Pass and San Geronio Pass are fortunate that large substations are located nearby. They have ready access to the high voltage transmission system which has capacity for power export. On the other hand, the expense of installing dedicated lines to a single windfarm can be very high and can substantially increase the effective installed cost of the plants -- by up to 50%.

## OVERVIEW OF WIND TECHNOLOGIES

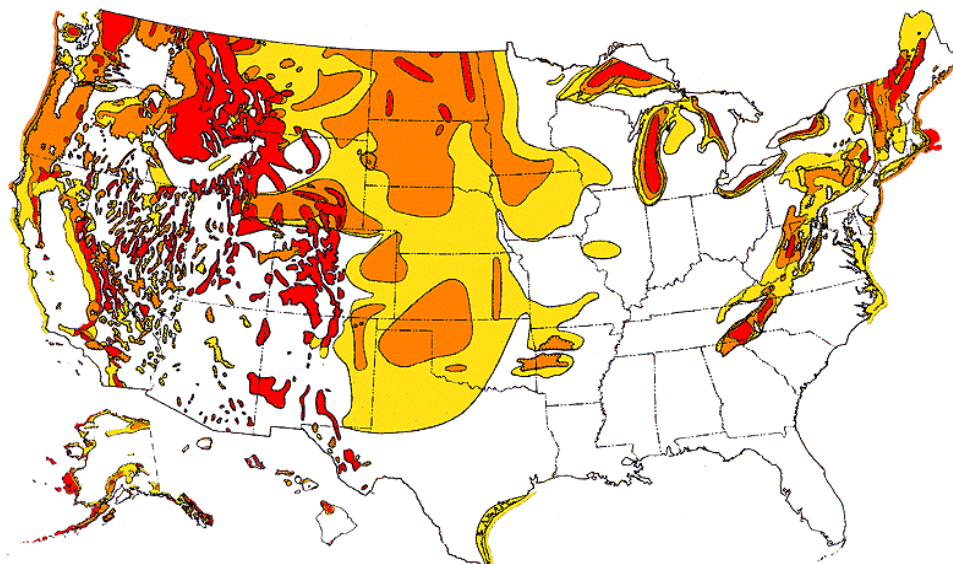

Wind Power Class	Wind Energy Resource Potential	Wind Power Density at 30 m [W/m <sup>2</sup> ]	Wind Speed at 10 m [mph]	Wind Speed at 30 m [mph]
3	Moderate	240-320	11.5-12.5	13.4-14.6
4	Good	320-400	12.5-13.4	14.6-15.7
5-7	Excellent	400+	13.4+	15.7+

Figure 1. U.S. wind energy resources.

The cost of transmission access is often not included in levelized cost of energy (COE) estimates from wind and other renewable sources. This factor is often excluded from analyses because such costs are site-specific and hard to estimate. In any specific region or for any particular project, a tradeoff between better wind resources and transmission cost and access will often exist. While the better wind resources produce more energy, they may be more remote and have higher associated site development and transmission costs. Therefore, wind resources in any area are unlikely to be developed cost-effectively exclusively from best sites to marginal sites. Rather, good resources with good transmission access and/or other favorable market factors may be developed before better resource sites with more expensive access or less favorable market factors.

Analysis by PNL has indicated that the amount of land exhibiting power class 4 or higher (land with no restrictions on wind energy development such as urban areas, park land, and bodies of water) is more than 9 percent of the contiguous U.S., or about 700,000 square kilometers [6]. This area is reduced to more than 450,000 km<sup>2</sup> under a PNL-defined "moderate" scenario of land exclusions. The moderate resource scenario excludes environmentally protected lands, urban areas, wetlands, 50% of forest lands, 30% of agricultural lands, and 10% of range and barren lands. The total amount of available land with power class 5 or higher is just over 1% of total land area, or about 90,000 km<sup>2</sup>. Using assumptions from the Technology Characterization and the PNL-defined moderate scenario of land exclusions, the resulting land areas equate to approximately 3,500 GW of installed (rated) wind capacity. This is far more than any market penetration estimates. Therefore, market penetration should not be constrained nationally by resource

## OVERVIEW OF WIND TECHNOLOGIES

availability. These assumptions for resource use equate to nearly 8 MW of installed (rated) capacity per square kilometer.

Since the amount of electricity generated by wind turbines increases quickly as the resource improves, it makes sense that -- for cases where all other costs are equal -- windfarm projects will tend to use the best resource sites in any region first. Using data from a recent NREL study on the proximity of wind resources to existing transmission capacity [8], Figure 2 shows the amount of available land, assuming the PNL "moderate" scenario, with wind resource classes 4, 5, and 6 within 10 miles (16.1 km) of available transmission lines. This analysis indicates that approximately 14% of current U.S. electric generation could be met by wind energy installed in class 5 or above resources within 10 miles of available transmission lines. Capacity additions beyond that level would have to utilize class 4 resources. The majority of the country's usable wind resource is in class 4. There is more than 25 times the resource available in class 4 than in class 6. For wind to maximize its geographic applicability, class 4 sites will eventually have to become cost effective. Additionally, it is important to remember that resource classes represent continuous ranges of resource quality. Thus, as the better developable sites are depleted, even within a given class, it will be important to keep improving the technology so that the lower wind speed sites will continue to become competitive.

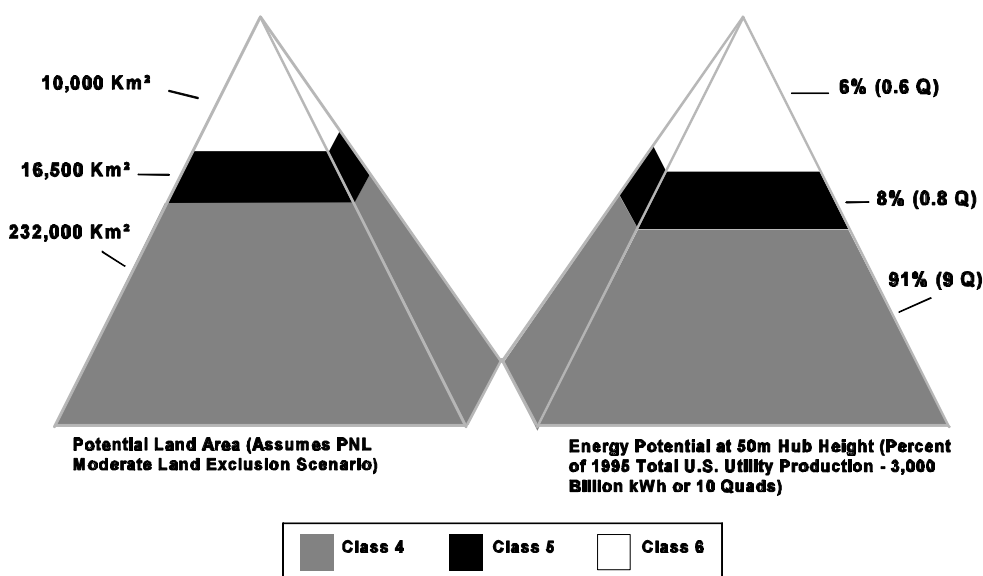

Figure 2. Potential wind energy within ten miles of transmission facilities.

### Tools For Conducting Analyses Using Data In This Document

Models are available to calculate cost of energy (COE) or rate of return for various project ownership and financing assumptions [9,10]. The FATE-2P model, developed by Princeton Economic Research, Inc. [10] is used to calculate COEs in a separate chapter of this TC compendium. Commercial tools to assist utilities in customizing analyses of windpower projects for site-specific conditions and turbine-specific design features do not currently exist. A recently developed wind energy curriculum entitled "Harvesting The Wind" is available from the Sustainable Resources Council, Minneapolis, Minnesota [11]. It includes a project feasibility assessment spreadsheet tool suitable for evaluating privately-owned wind energy projects in the Midwest. This tool, available on diskette, allows use of default

## **OVERVIEW OF WIND TECHNOLOGIES**

settings or customized input data for wind resource and turbine characteristics, and financial assumptions. In addition, EPRI recently published a primer for utilities on planning windpower projects [12].

1.0 System Description

The system described here is a 50 turbine windfarm consisting of horizontal axis wind turbines for supplying bulk power to the grid. The turbine size changes over time, as described in section 4, causing the windfarm to increase from 25 MW in year 2000 to 50 MW in year 2005 and beyond. There are many different system designs for current commercial wind turbines. Figure 1 shows a generic horizontal axis wind turbine system. Although there is no standard system for classifying wind turbine subsystems, this document breaks the components shown in the figure into 4 basic subsystems: (1) a rotor, usually consisting of two or three blades, a hub through which the blades attach to the low speed drive shaft, and sometimes hydraulic or mechanically-driven linkage systems to pitch all or part of the blades; (2) a drive train, generally including a gearbox and generator, shafts and couplings, a nacelle cover for the entire drive train, and often a mechanical disk brake and/or yaw system including a motor and gears; (3) a tower and foundation that supports the rotor and drive train; and (4) electrical controls and cabling, and instrumentation for monitoring and control.

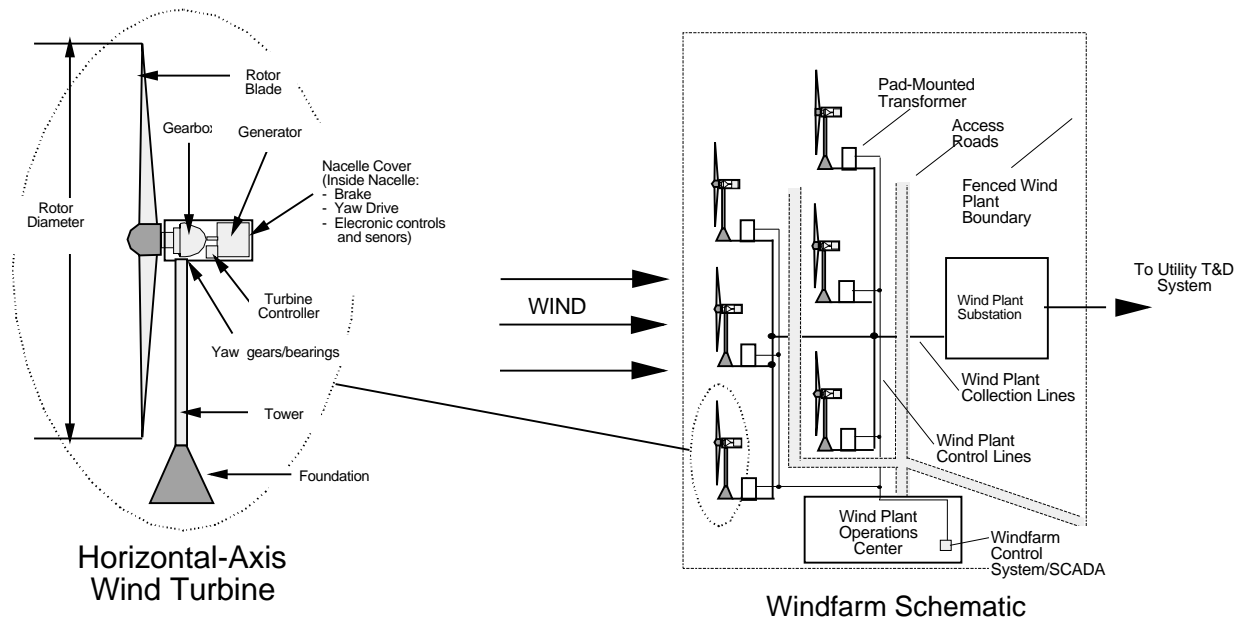

Figure 1. Horizontal axis wind turbine and windfarm system schematic.

The turbines characterized in this TC are composites that represent multiple, evolving design configurations for each 5-year time period. The generic turbine portrayed in Figure 1 can include any of these design features. For instance, one of several mechanisms may be employed to keep the rotor oriented properly in the wind stream. Some machines employ a non-motorized, or "passive" approach to control the turning, or yawing, motion while others have active motor-drive systems controlled by microprocessors. On most of the recently installed horizontal-axis machines, the blades are located on the upwind side of the tower; while a smaller number have been downwind. Some machines, called fixed-pitch turbines, have blades that are fixed to the hub in a single, stationary position, thereby reducing design complexity. Another design, called variable pitch, uses blades that can rotate (pitch) around their own axis in order to aid in starting, stopping, and regulating power output by changing the angle at which blades go through the air. Specific assumptions are made for each 5-year time period regarding the key design trends that are expected to drive cost and performance improvements. These are discussed in section 4.

## ADVANCED HORIZONTAL AXIS WIND TURBINES IN WINDFARMS

As shown in Figure 1, a windfarm is comprised of multiple turbines and various supporting balance of station (BOS) components exclusive of the turbines. These typically include roads, fences, ground support equipment for maintenance, operation and maintenance buildings, supplies and equipment, equipment for control of power flow and quality (e.g., switches, filters, and capacitors). Also included in BOS are electronics to control and monitor turbines in the windfarm (a microprocessor-based "Supervisory Control and Data Acquisition System," or SCADA), electrical wiring for power collection, and utility interconnection equipment such as transformers.

### 2.0 System Application, Benefits, and Impacts

**Major Application:** The major application for wind energy, in terms of potential for installed capacity, is the bulk power market. However, because of the changes underway due to utility restructuring, continuing low natural gas prices, and improving gas generation technology, the domestic market for wind energy is uncertain, especially in the near-term. The era of a single type of utility power project -- the utility-owned and operated facility -- is over. Traditionally, the primary markets for windfarms were thought to be conventional utility and Independent Power Producer-owned projects. These markets may continue to provide opportunities. In the future, however, as utility restructuring accelerates, additional types of market opportunities may emerge, providing more near-term targets for wind energy.

Municipally or publicly owned utilities may be one such market. Other potential opportunities include ownership by cooperatives, power marketers, or aggregators, who package generation from several technologies, including renewables and (possibly) natural gas or hydroelectric, to add capacity value, and direct access customers. Smaller clusters of turbines owned by private land owners may be another near-term niche. High wind resources and favorable financing mechanisms will be typical for near-term projects. In addition, wind energy will be most competitive in applications where value beyond short-term avoided cost is recognized. Such applications could include distributed generation, or "green" power markets, whereby the energy is valued for its environmental benefits, or reduction of other impacts from fossil or nuclear power.

**System Benefits:** As the utility market shifts away from its recent structure, it will be increasingly important for sellers of wind energy to distinguish their product from other generation sources by emphasizing value that customers will recognize in the marketplace. The introductory chapter of the TC compendium details benefits common to all renewable energy technologies. Specific sources of added value from wind energy include:

Economic: Wind turbines located in agricultural areas can enhance land values by boosting rents and prices, while leaving the majority of the land for continued agricultural use. Windfarms, because of their modularity, have the potential for distributed and/or strategic siting, which can help power providers optimize the use of existing transmission and distribution facilities or defer the need for equipment upgrades or line extensions. Such values are highly dependent on specific utility systems and wind sites.

Risk Management: Wind energy shares many of the positive risk management attributes as other renewables, as detailed in the TC compendium introduction chapter. Wind energy may be uniquely positioned to add value in some instances, e.g., where coincidence of resource and load is high, or where the combination of economics and environmental impacts is the most favorable compared with the alternatives.

Environmental: Once installed, wind energy enjoys the advantages of zero air, water and solid waste emissions. In addition, total fuel-cycle emissions, including emissions experienced during construction, fuel extraction (zero for wind) and operating cycles, are very low compared with all fossil fuels and many other types of generating technologies. These



## ADVANCED HORIZONTAL AXIS WIND TURBINES IN WINDFARMS

environmental advantages can help power companies meet environmental regulations and satisfy their customers' desire for clean power sources.

**System Impacts:** Several potential localized impacts that windfarm designers and developers pay close attention to include avian interactions, visual or aesthetic impacts, land erosion around turbine pads or roads, and acoustic impacts. Wind power plants can affect local habitat and wildlife as well as people. The degree of impacts from these issues can vary from non-existent to critical, depending on site-specific characteristics of each project, e.g., proximity to human and avian population, type and use of surrounding land, and local preferences for land use. Developers must carefully consider these characteristics when siting windfarms in order to mitigate potential impacts to acceptable levels.

Of the approximately 5 billion annual bird deaths reported in the United States, 200 million are a result of collisions with man-made objects [14]. Experience over the past decade has shown that the level of bird mortality from interaction with windfarms can vary from none in some areas to levels of concern in others, such as where windfarms are sited in migratory pathways or in dense avian population centers, such as Altamont Pass, California. Bird collisions with wind energy structures are the leading cause of mortality reported. Electrocutions are the second leading cause, but solutions have been developed to mitigate this problem [15]. Other factors that influence the potential for avian collisions with wind energy facilities include land use, turbine design, turbine location, turbine orientation, operation methods, bird species, habitat use, and avian perching and flying behavior. Researchers performing studies at wind energy facilities in the United States and Europe report that mortalities are not considered biologically significant to overall populations [15], indicating that these impacts may be less than from many other man-made objects. However, regardless of the relative size of the impact from wind projects, minimizing the cumulative impacts on avian populations is still a critical requirement for wind energy growth domestically and abroad.

Windfarm developers and operators currently have the ability to mitigate a large portion of avian impacts by proper design, siting, and operation of wind turbines and windfarms. The ability to mitigate avian impacts is site-specific. In addition to employing design techniques such as using tubular towers to reduce perching or burying wires or covering connections to reduce electrocutions, developers may also have to avoid using all or parts of certain high risk areas. Research is ongoing to develop methods to minimize impacts from current installations and develop the ability to further mitigate impacts from developments yet to be installed.

The visual impact of wind turbines can be quite noticeable. Wind turbines are tall structures, often located on the tops of ridges and hills, and can be visible from relatively long distances. Experience shows that the layout of a wind power plant, type of tower, and color of the turbine and tower affect some people's aesthetic sensitivity. Finally, noise is caused by the air moving over the turbine blades (aerodynamic noise) and by the turbine's mechanical components. Engineers have reduced aerodynamic noise by design changes such as decreasing the thickness of the trailing edge of the blades and by orienting blades upwind of the tower. Since turbines still emit some noise, it is prudent for windfarm developers to consider proximity to residential areas when selecting development sites.

### 3.0 Technology Assumptions and Issues

Wind technology is currently commercially available, but limited production volume tends to push current prices higher. The performance and cost indicators in this TC are composite numbers representing this commercially available technology. A high/low range is placed on this data to portray an envelope of cost/performance projections. A composite represents a combination of different design characteristics -- that is, it reflects different designs and design paths that may achieve similar results in terms of leveled cost of energy or other measures that combine cost, performance, and reliability. Because this characterization presents composite data, the specific cost and performance characteristics of any

## ADVANCED HORIZONTAL AXIS WIND TURBINES IN WINDFARMS

commercial system will be different from those presented here. The envelope of technology represented in this document includes worldwide technology. Estimates for current and future technology are based on U.S. applications and market conditions. The projected technology path assumes robust R&D funding from public and private sources will continue.

The wind resource assumed in this TC analysis is characteristic of broad areas of land available in the U.S. As wind energy technology improves, abundant lower wind resource areas will become cost effective. Evaluated here are Class 4 winds, with average annual speeds of 5.8 m/sec (13 mph) at 10 meters above ground, and Class 6 winds, with average annual speeds of 6.7 m/sec (15 mph) at 10 meters above ground. A Rayleigh distribution is assumed for these annual average windspeeds and the 1/7 power law is used to account for wind shear effects when scaling wind speed to hub heights. More detailed information on wind energy resources may be found in [7]. Also, a handbook for conducting wind resource assessment, recently completed for the National Renewable Energy Laboratory [16], is a good reference for siting windfarms and turbines.

**R&D Needs:** Manufacturers are developing the next generation of wind turbines in the U.S. and Europe. Government support of markets in Europe, India, and other developing countries, has been largely responsible for burgeoning sales, providing manufacturers with cashflow to conduct private development efforts. European manufacturers currently supply most of the world market for utility-scale wind turbines and therefore provide the majority of the private investment in R&D. Government-sponsored R&D, through national laboratories, also plays an essential role in developing new wind energy technology. The wind industry, as a whole, is still small enough, in terms of financial resources, to require shared research and testing in certain areas. Continuing applied R&D to develop the technical knowledge base necessary to design more cost effective and reliable turbines is critical to any company hoping to compete successfully in the marketplace five or more years from now: competition will not only be within the wind industry, but against improved fossil generating technologies. Research and testing of current advanced components and subsystems is also critical for manufacturers to compete in near-term markets.

This technology characterization does not detail the specific and significant R&D advances that are implicit in the technology trajectory presented. However, this R&D will be essential to develop simpler, more efficient, lighter systems with larger rotors and taller towers, while maintaining high reliability and equipment lifetimes. Although it may appear simple in concept, achieving substantially improved cost effectiveness through larger rotor size and tower height is technically challenging. Research will be needed to enable industry to first understand damaging loads that increase with larger systems, and then to employ methods to reduce or control the impact of those loads in the context of improved overall system economics.

Research in other areas is essential to achieve the projected improvements. This includes developing a better understanding of (1) the characteristics of the wind "seen" by the turbine; (2) how turbines interact with the wind ("aerodynamics"); (3) how turbine structures and materials respond to such interactions and how manufacturers can use this knowledge to design stronger, less expensive components; (4) individual component advances and how they may be combined with other components into more cost effective systems; and (5) other ways of increasing the value of wind energy, such as improving the ability to forecast wind resource levels at longer time intervals into the future. The U.S. DOE Wind Energy Program regularly publishes detailed descriptions of its current and planned R&D activities aimed at these and other R&D opportunities.

### 4.0 Performance and Cost

Table 1 summarizes the performance and cost indicators for advanced horizontal wind turbines in windfarms being characterized in this report.

## ADVANCED HORIZONTAL AXIS WIND TURBINES IN WINDFARMS

Table 1. Performance and cost indicators.

INDICATOR NAME	UNITS	Base Case		2000		2005		2010		2020		2030	
		1996	+/- %		+/- %		+/- %		+/- %		+/- %		+/- %
Plant (windfarm) Size	MW	25		37.5		50		50		50		50	
Turbine Size	kW	500		750		1,000		1,000		1,000		1,000	
Hub Height	m	40		60		70		80		90		100	
Rotor Diameter	m	38		46		55		55		55		55	
Swept Area	m <sup>2</sup>	1,134		1,662		2,376		2,376		2,376		2,376	
<b>Performance</b>													
Annual Energy delivery			+5/-15		+10/-20		+10/-25		+10/-25		+10/-25		+10/-25
Class 4 (plains site)	GWh/yr	57		99		154		159		164		168	
Class 6 (ridge site)	GWh/yr	78		133		199		203		210		213	
Net Annual Energy/Rotor Area			+5/-15		+10/-20		+10/-25		+10/-25		+10/-25		+10/-25
Class 4 (5.8 m/s @ 10 m)	kWh/m <sup>2</sup>	1,011		1,192		1,294		1,334		1,385		1,412	
Class 6 (6.7 m/s @ 10 m)	kWh/m <sup>2</sup>	1,372		1,596		1,671		1,711		1,765		1,797	
Capacity Factor			+5/-15		+10/-20		+10/-25		+10/-25		+10/-25		+10/-25
Class 4	%	26.2		30.2		35.1		36.2		37.6		38.3	
Class 6	%	35.5		40.4		45.3		46.4		47.9		48.7	
Annual Efficiency	% of theoretical maximum												
Class 4		65.0		71.8		75.3		75.4		76.4		76.2	
Class 6		70.4		78.9		80.2		80.3		81.3		81.4	
Annual Losses	% of gross energy												
Class 4		17.5		12.5		11.0		11.0		10.0		10.0	
Class 6		12.5		7.5		6.5		6.5		5.5		5.5	
Availability[1]	%	98	+1/-2	98	+1/-2	98	+1/-2	98	+1/-1	98	+1/-1	98	+1/-1

## ADVANCED HORIZONTAL AXIS WIND TURBINES IN WINDFARMS

Table 1. Performance and cost indicators.

INDICATOR NAME	UNITS	Base Case		2000		2005		2010		2020		2030	
		1996	+/- %		+/- %		+/- %		+/- %		+/- %		+/- %
<b>Capital Cost</b>													
Rotor Assembly (including hub)	\$/kW	185		180		190		160		150		140	
Tower	\$/kW	145		145		185		195		215		235	
Generator	\$/kW	50		45		55		50		45		40	
Electrical/Power Electronics, Controls, Instrumentation	\$/kW	155		140		100		90		75		65	
Transmission/Drive Train, Shaft Brakes, Nacelle	\$/kW	215		50		40		35		35		30	
Turbine FOB	\$/kW	750		560		570		530		520		510	
Balance of Station (BOS)	\$/kW	250	+5/-20	190		150		145		135		125	
Total Installed Cost	\$/kW	1,000	+10/-20	750		720		675		655		635	
Total Installed Cost	\$million	25.0	+10/-20	28.1	+20/-20	36.0	+20/-20	33.8	+20/-20	32.7	+20/-20	31.7	+20/-20
Cost per swept area	\$/m <sup>2</sup>	441	+10/-20	338	+20/-20	303	+20/-20	284	+20/-20	276	+20/-20	267	+20/-20
<b>Operations and Maintenance Cost</b>													
Annual O&M Cost *	\$/turbine	10,000	+20/-30	10,400	+20/-30	11,700	+20/-30	11,300	+20/-30	11,100	+20/-30	11,000	+20/-30
	\$/kW-yr	20.00	+20/-30	13.87	+20/-30	11.70	+20/-30	11.30	+20/-30	11.10	+20/-30	11.00	+20/-30
Levelized Overhaul and Replacement Cost	\$/kW-yr	4.8	+20/-50	4.3	+20/-50	3.6	+15/-50	3.1	+15/-50	2.2	+15/-50	2.1	+15/-50
Annual Land Lease [1,15,16]	% of revenue	3.0	+30/-30	3.0	+30/-30	2.5	+40/-30	2.5	+40/-30	2.5	+40/-40	2.5	+60/-40

Notes:

1. The +/- range bounds a technology envelope that includes emerging/leading technology characteristics on the + side for performance and on the - side for cost. The range also includes uncertainty of achieving technical success and sales volume, and the natural variation in projects from normal market demands.

2. Plant (windfarm) construction period is assumed to require 1 year.

\* Annual O&M is expressed as \$/turbine and \$/kW-yr. These are two expressions of one cost and are therefore not additive.

## ADVANCED HORIZONTAL AXIS WIND TURBINES IN WINDFARMS

### 4.1 Evolution Overview

Table 2 summarizes the projected composite technology path. Figure 2 shows the associated major technical trends expected in wind turbine development. One of the concepts the figure illustrates is that while there may be major innovative advances in the technology which drive COE down, simultaneously, there will be an ongoing process of incremental optimization. Major innovation is reflected by "jumps" in both size and subsystem type from 1995 to 2000, and again from 2000 to 2005. The optimization process is shown as the bottom arrow "feeding" the major improvements above. The "jumps" in technology shown in the figure denote a broad technology development trend, but they do not indicate that a single design path is projected. Section 4 details the assumptions and rationale associated with this progression for each time period addressed by the TC.

Table 2. Projected composite technology path.

Year	Turbine Rated Capacity (kW)	Turbine Diameter (m)	Hub Height (m)	Basis For Composite Technology Description
1996	500	38	40	Based on several commercial turbines.
2000	750	46	60	Based on several preliminary DOE Next Generation turbine designs, current prototypes, analysis from R&D activities, and manufacturer reports of next generation technology plans.
2005	1000	55	70	Advances are driven by an additional cycle of turbine research activities. Projections are based on internal laboratory analysis.
2010	1000	55	80	Post 2005 incorporates incremental technology advances. Modest cost reductions are primarily from manufacturing improvements and increased volume.
2020	1000	55	90	
2030	1000	55	100	

A useful and interesting treatment of wind energy is contained in a recent study by the Union of Concerned Scientists (UCS) of the use of renewables in the Midwest [8]. The UCS study used a geographical information system to refine wind resource estimates developed originally by Pacific Northwest Laboratory (PNL). The UCS study identifies availability of transmission lines and estimates cost of transmission lines to wind resources in most midwest states. Sites are identified that could be developed cost-effectively, now or in the next few years, with improving technology and a broad planning perspective.

## ADVANCED HORIZONTAL AXIS WIND TURBINES IN WINDFARMS

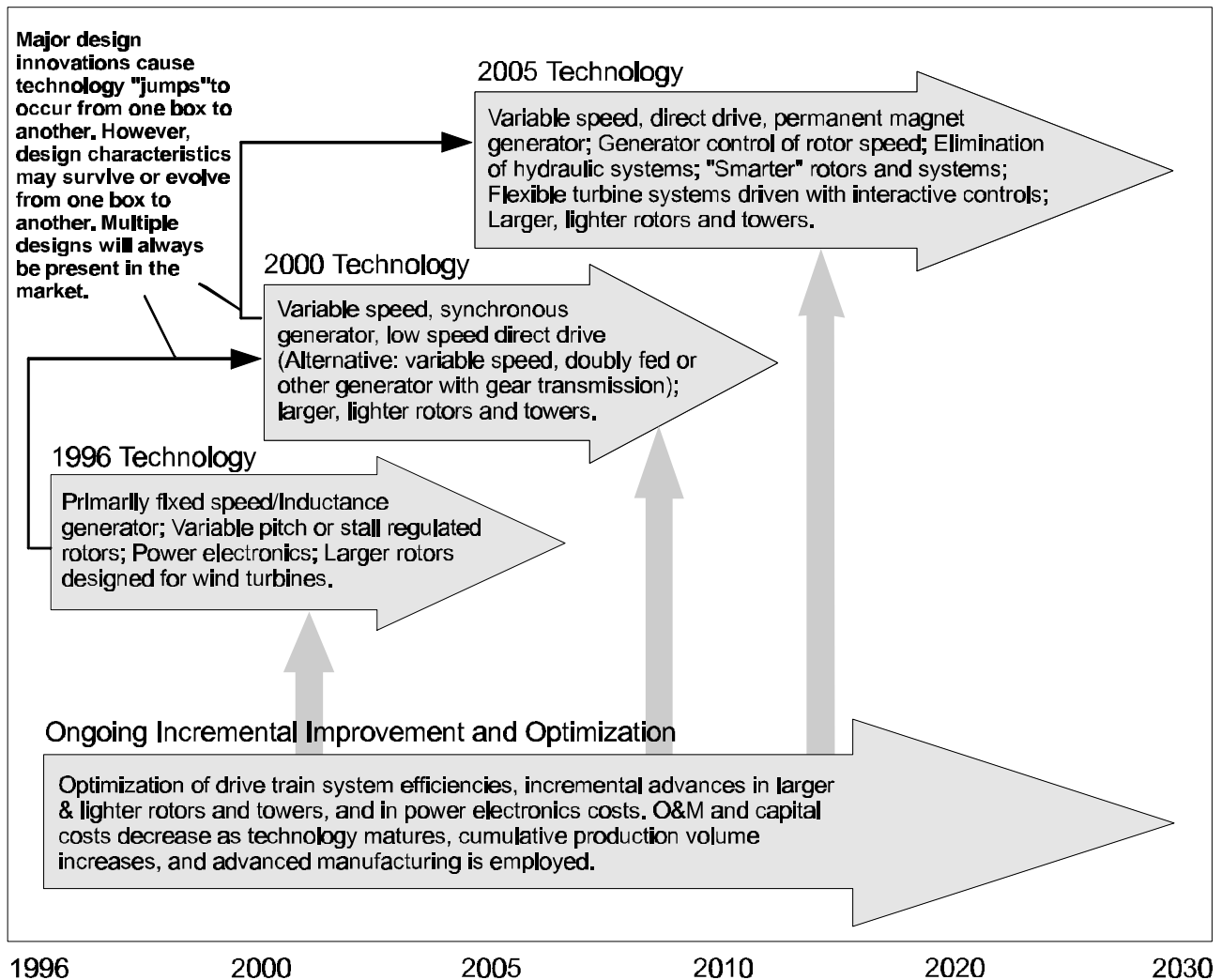

Figure 2. Wind energy technology evolution.

Multiple designs will always be present in the market, with different design characteristics surviving or evolving from one time period to another. Depending on the market application and customer needs, turbines with different individual cost and performance characteristics have the ability to compete in the market. It is recognized that designs are not driven solely by economic and technical factors; manufacturer philosophy and the nature of the market also dictate the length of time that design features remain in the market. Additionally, designs are driven in part by the need to conform to certain design standards in order to receive certifications that enable sales in some areas overseas. The diversity of design approaches currently being pursued by manufacturers increases the probability of successfully achieving the composite projections.

The TC baseline, 1996 turbine, described in the introduction section, represents a composite of public data collected for several commercially available wind systems. Most of these wind systems include fixed-speed generating systems, usually coupled with a low-cost induction generator. Many systems use power electronics for power conversion and/or dynamic braking, and advanced airfoil designs. A few current designs utilize variable speed generation systems. The

## ADVANCED HORIZONTAL AXIS WIND TURBINES IN WINDFARMS

characterization includes turbines evolving along several design paths. The first may be termed advanced lightweight designs. This includes turbines such as Flowind's AWT-27 and Northern Power Systems North Wind 250, both developed under the DOE Near-Term Product Development Project, and by other manufacturers such as Cannon/Wind Eagle Corporation. The advanced lightweight design path continues to be pursued for the 2000 time frame, including by manufacturers participating in DOE's Next Generation Turbine Development (NGTD) Project activity. Some technology in 2000 will also incorporate advanced components developed by industry, privately, and in conjunction with DOE's Innovative Subsystems activity. Lighter designs are also being developed or investigated by several manufacturers in Europe.

A second design path originates from the 3-bladed, rigid hub, fixed pitch design, sometimes referred to as the Danish-style turbine. This design approach continues to be advanced by U.S. and European manufacturers. A recently commercialized design by Zond Energy Systems, Inc., in conjunction with DOE's Value Engineered Turbine activity, has achieved improved cost effectiveness, as measured by the levelized cost of energy. European manufacturers have also developed advanced subsystem features for this basic design approach, including full or partial variable speed operation, and power electronics for rotor and generator control.

A third path, which may now be converging with the first two, can be described by the technology developed originally by Kenetech in the U.S. and by Enercon in Germany. This includes turbines utilizing power electronics to achieve variable speed generation. In 1993, Kenetech Windpower developed a 33-meter, 3-bladed, variable speed turbine with several industry partners. By 1996, Kenetech had also designed and tested a 45-meter turbine. Although Kenetech Windpower recently ceased operations, several of the design features envisioned for its next generation of technology were similar to those now being investigated or incorporated by others on the first two paths. Foremost among these include variable speed, variable pitch, and direct drive operation. Enercon produces commercial variable speed, direct-drive machines, but further R&D is required to bring down the cost of its electronic components and optimize its power conversion efficiency such that its cost effectiveness is in the competitive range of projections for 2000.

The 2000 composite turbine is expected to utilize a combination of tested and developmental subsystems. The direction of 2000 technology, as reflected in Figure 2, is generally toward larger generators and rotors; multiple speed or advanced variable speed generators, including increased use of power electronics; more sophisticated control electronics; advanced aerodynamic controls; tailored airfoils for specific wind regimes; taller towers; and early introduction of low-speed, direct-drive generators [17,18]. It will be possible to design turbines for greater reliability based on a better knowledge of wind inflow characteristics and how they impact structural design. It is expected that there will be improvements in turbine blades, particularly with respect to better integration of blade structural and aerodynamic design with appropriate manufacturing processes. In addition, developers will improve their ability to site turbines in order to optimize windfarm operation and energy production [17]. Figure 2 lists two alternative technology paths for 2000: 1) a variable-speed, synchronous generator with fully rated converter (electronics that allow elimination of the gear box), and 2) a doubly-fed generator, that is seen as an interim, low-cost, variable-speed generation option, with a geared transmission. These two alternatives hardly begin to cover the possible configurations that could emerge in the market, but they provide examples of potentially common technologies for the 2000+ time period.

Advances in 2005 are expected to be driven in part by an additional cycle of government-industry financed turbine research projects. Based on the potential identified in internal laboratory analysis [19], the TC assumes that the move toward direct drive systems continues, along with lower cost power electronics and increasing sophistication in control electronics, and more responsive rotor power control and associated load reduction using technologies such as rotor ailerons or pitch activation. These advances are combined in the composite technology path with the last major size increase in rotor diameter and generator rating. Although opinions differ on what the ultimate optimum wind turbine size will be in the future, several industry scaling studies have indicated that sizes near 1 MW appear to yield the approximate optimal tradeoffs between cost, performance, and reliability for large windfarm applications. Permanent magnet

## ADVANCED HORIZONTAL AXIS WIND TURBINES IN WINDFARMS

generators start to become cost-effective for windfarm-size turbines in 2005. Finally, a trend towards incrementally higher towers is expected.

Turbine generator rating is not expected to increase significantly after 2005, because inverse economies of scale may hinder turbine development of machines larger than one megawatt [19]. Tower heights increase throughout the entire projection period. This reflects the belief that systems in the future will trend toward higher towers, with the optimal height determined on a project- and site-specific basis. Not all turbines sold in the market will have towers as tall, or as short, as the height specified in the wind TC. Improvements in design software and general reductions in turbine weight per unit output will permit this trend in the optimum design point for turbine towers. Technical advances after 2005 are also expected in the areas of lightweight materials, especially blade materials, and advanced techniques and components to enhance turbine load shedding.

### 4.2 Performance and Cost Discussion

#### Key Assumptions

**Expected economic life (years):** The expected economic life for the windfarm project is 30 years, based on manufacturers' field experience of nearly 15 years and stated design goals [20]. Periodic replacement or refurbishment of major subsystems such as rotor blades or generator windings are assumed to be necessary during the 30-year period, although not all manufacturers claim to require blade replacement in that period. Some researchers feel that sufficient data on component cycle loads, composite material performance prediction, and extended operation over a 30-year period do not currently exist to make accurate predictions of lifetime as long as 30 years.

**Construction financing costs:** These are not included in the \$/kW capital cost estimates in Table 1. However, they should be incorporated into any COE calculation and they are included with COE's in the separate finance chapter. Capital cost estimates in Table 1 may therefore be termed "overnight" costs.

**Profit:** Turbine FOB (cost of turbine at manufacturer loading dock) costs include profit.

**Windfarm Size:** Fixing the number of turbines at 50 units allows cost trends to be examined more readily on the subsystem level in terms of absolute dollars as well as dollars per rated-kilowatt.

**Capacity Factor:** Capacity factor, as used in Table 1, is defined as the net amount of power produced annually by the turbine divided by the amount of energy that would be produced if the turbine operated at full rated capacity for the entire year. As such, it is a function of both wind resource (how often wind speeds are high enough for the turbine to cut-in) and turbine reliability (how often the turbine is available for operation when the wind is blowing versus how often it is unavailable due to scheduled and unscheduled maintenance).

#### Current Technology (1996)

**Current Performance:** Operational data for current technology is widely available from California windfarms and other locations around the world. Performance indicators for the base year are a composite of commercial technology available in 1996, including turbines from the DOE Near-Term Product Development Project [21-23] and from several other manufacturers [24]. These turbines include fixed and variable speed designs, most of which use one or more low cost, induction generators. The 1996 technology composite is distinguished from earlier technology, late 1980s/early 1990s, by the substantial use of power electronics for power conversion and/or dynamic braking, and by the use of advanced airfoil designs. Projects using these types of technology currently exist. Additionally, manufacturers have achieved high turbine availability with recent projects using these turbines or their direct predecessors [25].





## ADVANCED HORIZONTAL AXIS WIND TURBINES IN WINDFARMS

Publicly available power curves for these turbines are used to run the same energy model that was used to calculate the wind TC composite energy production estimates to produce comparable energy output estimates for class 4 and class 6 wind sites. For comparison, all turbines are normalized to the hub height of 10 meters to eliminate the effect of different tower heights associated with the different commercial turbines.

Table 3. Comparison of current turbine performance with 1996 TC composite turbine.

	Turbine Rating (kW)	Rotor Diameter (m)	Annual energy (kWh/m <sup>2</sup> normalized to 10 m hub height, no losses, 100% availability) *	
			Class 4	Class 6
Minimum Value	275	26.8	519	790
Maximum Value	750	46.0	833	1,127
Mean Value	531	39.4	706	992
Std. Deviation	131	5.6	69	83
TC Value	500	38.0	777	1088

\*10 meters is height at which wind speeds are measured. Normalization eliminates effect of tower heights.

Table 3 shows that the 1996 TC turbine rotor diameter and rating are similar to the mean values of the 17 turbines. The 1996 annual energy estimates for the TC turbine are one standard deviation above the mean values for the 17 turbines for both the class 4 and class 6 calculations. Since the turbines in this data set are optimized for various wind regimes, the result of this statistical analysis tends to overstate the distance of the TC value from the mean. That is, the TC energy production would be closer to the mean of those turbines if they were all optimized for the TC wind resource assumptions. Thus, the composite performance estimate represents leading commercial technology, but is still under the maximum value for current machines. Individual turbines are not shown in the table because manufacturers were not given the chance to optimize their turbines for the TC wind resource assumptions. However, it is assumed that the large number of turbines included provides a reasonable range against which to benchmark the TC composite estimate for current technology. The uncertainty range for 1996 energy indicators in Table 1 is within the bounds created by the minimum and maximum values listed in Table 1.

Windfarm Losses - A breakdown of assumed losses is shown in Table 4.

- *Array Losses* - Large downwind spacing dimensions (2.5 diameters sideways x 20 diameters downwind) have been assumed for class 4 sites because land is most often found in flat plains areas and is abundant for this resource class. Based on judgement of DOE laboratory researchers, this relatively large spacing is the primary reason for reduction of array losses from levels currently reported in some large, densely-sited windfarms in California. Array losses are assumed to be zero for the higher class 5 and 6 sites because these resources are often found in ridge or mountainous terrain and turbines are typically situated large distances downwind from one another or in long, single rows.
- *Soiling losses* - 1996 values are based on (1) tests of airfoil designs developed by NREL and available commercially, that exhibit low sensitivity to soiling ("roughness") [28,29] and (2) the assumption that blade washing is conducted at economically optimal levels and the associated cost is included in the annual O&M. Introduction of variable pitch rotors in the 2000 TC design further reduces soiling losses; the pitch control is assumed to compensate for degradation of aerodynamic performance from soiling. Soiling losses decrease slightly after 2010, indicating that airfoil design and materials will not yet be fully optimized for roughness insensitivity until then.

## ADVANCED HORIZONTAL AXIS WIND TURBINES IN WINDFARMS

Table 4. Windfarm loss assumptions (% of calculated gross energy).

	1996	2000	2005	2010	2010-2030
Array	5 / 0*	5 / 0	4.5 / 0	4.5 / 0	4 / 0
Rotor Soiling	7.5	2.5	2.5	2.5	2 / 0
Collection System <sup>†</sup>	2	2	2	2	2
Control & Misc.	3	3	2	2	2
Total	17.5 / 12.5	12.5 / 7.5	11 / 6.5	11 / 6.5	10 / 5.5

\* Pairs indicate losses for wind (class 4 sites / classes 5 & 6 sites)

<sup>†</sup> Includes wire and transformer losses

**Current Cost:** Using public price quotes and engineering cost studies as the primary basis for the TC 1996 turbine FOB price estimate raises several issues. Foremost among these include:

- Differences may exist between advertised list prices, which are quoted by manufacturers for marketing purposes, and actual market prices, which are project-specific, depending on what the market will bear.
- Price estimates derived from engineering studies are based on production cost plus an assumed profit, which may not match current market conditions. A major source of uncertainty in turbine capital cost estimates comes from trying to infer turbine and windfarm costs from quoted prices. That is, competitive pricing strategies can make it difficult to determine true costs.
- Differences in, or lack of definition of, the volume of production associated with cost estimates and price quotes. This applies both to the cumulative volume, which determines how much cost reduction has been obtained through manufacturer "learning," and to the volume of the individual or annual production run associated with the cost, which affects the cost of purchased subcomponents, manufacturing materials, and distribution of fixed overhead costs. Normalizing estimates for these factors must often be attempted with imperfect information. Turbine costs in the TC for 1996 assume that the manufacturer has achieved a cumulative production volume of approximately 150 units prior to 1996 and that the size of the production run associated with the cost estimates is approximately 150 units.
- The differences between the U.S. market and other markets around the world, e.g. differences in subsidies, application size and type, ownership/financing, and exchange rate fluctuations and that most recent projects have been installed in countries other than the U.S., increase the difficulty of using recent market prices and quotes that are directed primarily at those markets.
- The difficulty in determining what costs are included in price quotes, e.g., substation costs or project management fees.

There is a large data set of current prices resulting from the substantial world-wide wind turbine industrial base. The 1996 TC cost composite draws from a combination of public information from manufacturers and published price quotes [25,30,31]. A statistical summary of this data from references 25 and 30 is shown in Table 5. Eleven turbines from eight manufacturers are included in this analysis. Assumptions concerning associated cumulative and annual production volume are not available from the data sources. European turbine list prices from [30] were reduced 15 percent due to the following reasons:

- Reference 30 is a document for general public information. Actual market prices will vary depending on many project-specific factors.

## ADVANCED HORIZONTAL AXIS WIND TURBINES IN WINDFARMS

- It is assumed that manufacturers quoted prices for their primary current market, Europe, which is supported by various market subsidy programs, especially in Germany. It is further assumed that subsidies tend to support somewhat higher prices.

Total installed costs are calculated in Table 5 by increasing FOB cost by the 1996 wind TC value of \$250/kW for BOS costs. Since the FOB cost was not available for the Zond Turbine, the installed project cost estimate was taken from a 1994 public briefing by the manufacturer and is assumed to be an estimate for general analytic purposes only [25]. The table shows that the 1996 wind TC composite cost estimate is close to the average value of this data set, after the 15% turbine price correction.

The 1996 TC cost does not include data points for two lightweight designs because they have not seen recent sales in the market. Nonetheless, costs associated with these designs appear to be significantly lower than those represented in Table 5. Reference 30 gives a list price for the Carter CWT-300 at \$666/kW. This turbine was developed several years ago. In addition, current experience with the production of six prototypes of the later free tilt, free yaw Cannon Wind Eagle 300 design indicates that the 1996 TC figure could easily be met or surpassed with current technology [32]. In addition, a detailed engineering cost analysis performed under the DOE Near-Term Product Development Project estimated the on-site cost for 500 WC-86B turbines (the precursor to the AWT-27) including a 15% profit mark-up, to be \$568/kW in 1992 dollars. Total project cost estimates depended on site-specific assumptions, but were approximately \$800/kW [21].

Table 5. Comparison of current turbine costs with 1996 TC composite turbine estimate.

	Turbine List Price (\$/kW, Jan. 1997 \$)	Total Installed Cost (\$/kW, Jan. 1997 \$)
Minimum Value	723	973
Maximum Value	841	1091
Mean Value	758	1007
Standard Deviation	35	36
Median Value	744	994
1996 TC Value	750	1000
Number of Estimates	10	11
Mean Hub Height (m)	43.6	43.4

This characterization assumes, as a baseline for calculating future cost reductions, that the nominal cumulative and annual production volume for 1996 technology is approximately 150 units. However, it is not possible to normalize the data in Table 5 for different cumulative or annual production volumes because it is not known what production volume assumptions are behind the prices.

A low range of uncertainty in 1996 costs is shown on Table 1, reflecting extensive commercial experience to date. The larger uncertainty on the low side of the cost indicators, reflects the lower costs reported for emerging technology such as the Cannon/Wind Eagle 300. Estimates for emerging technology are not considered validated until a sufficient number of turbines have proven themselves in the field. In addition, market prices may be higher or lower than the stated bounds, depending on project-specific details such as access to transmission lines, and competitive circumstances.

## ADVANCED HORIZONTAL AXIS WIND TURBINES IN WINDFARMS

### Technology Projections 2000 - 2030

**Future Performance:** Manufacturers are pursuing multiple design paths for year 2000 technology with the goal of achieving the system-level cost effectiveness represented by the 2000 wind TC characterization. Performance indicators for year 2000 technology are based in part on information from the DOE Next Generation Turbine Development (NGTD) Project. Data from that project is based on designs still in the pre-prototype stage.

The following two turbines are currently being investigated under the NGTD Project. The turbine descriptions are for current concepts, but do not now represent actual turbines.

- The Wind Turbine Company WTC 1000 is a downwind two-speed, variable-pitch turbine rated at 1000 kW. The rotor incorporates variable rotor coning to attenuate loads and the drive train employs multiple generators. The turbine employs a passive-yaw system to reduce mechanical complexity.
- The Zond Z-56 is an upwind, variable speed, variable-pitch turbine rated at approximately 1.1 MW. It employs 3 blades in an upwind configuration, an active yaw system, a variable-speed, doubly-fed generator, and advanced NREL airfoils.

Table 6 details the projected performance gains for 2000 and each subsequent five-year interval up to 2030. The table lists gains as a percent of the 1996 baseline turbine and as a percent of the previous period's value. The table also shows the percent of incremental increases from the previous time period for each 5 year interval due to each driver. As shown in Table 6, the three largest drivers of increased energy in 2000 are taller towers, larger rotors, and reduced system losses from soiling. The energy estimate for the 2000 composite turbine assumes a variable speed generator system and a variable pitch rotor. However, because it is anticipated that variable speed systems will still be undergoing substantial development for wind turbine applications, it is assumed that the associated electronic power conversion system is not fully optimized. That is, due to limitations on individual component efficiencies, especially power-electronic conversion capabilities, it is assumed that introduction of variable speed operation will result in only modest net performance gains. A recent investigation concludes that realizing the benefits of increased energy output from variable speed operation requires advanced direct-drive architectures and more advanced power electronic conversion capabilities [33]. The table reflects these conclusions by showing zero-to-modest gains from variable speed in 2000, with substantial gains still possible in later years. This may be a conservative assumption, as industry is currently pursuing several different approaches to variable speed configurations and preliminary projections of the net performance/cost tradeoff for these vary.

A range of values is given in Table 6 for two primary reasons. The first is uncertainty related to technological development. The second, and larger, is that systems utilize an optimized combination of various subsystems involving tradeoffs between cost and performance of each subsystem. That is, subsystems are combined to maximize the cost effectiveness of the system as a whole. Since tradeoffs must be considered when employing various subsystems and design approaches, no single system can utilize every component or operational approach with the very highest individual performance characteristics.

The broader uncertainty range, associated with year 2000 performance estimates, listed in Table 1, reflects increased technology-related uncertainty compared to the 1996 range. The low side is increased again in 2005 for the same reason.

## ADVANCED HORIZONTAL AXIS WIND TURBINES IN WINDFARMS

Table 6. Performance improvement drivers.

	Increase in Net kWh/m* (percent)		Percent of Incremental Increase from Previous Time Period (percent) <sup>†</sup>			
	From 1996 Baseline	From Previous Period	Taller Towers	Larger Rotors or Improved Aerodynamics	Lower Assumed Losses from Soiling	Variable Speed + Drive Train & Power Conversion Efficiency Optimization <sup>‡</sup>
2000	16-18	16-18	50-70	5-10	27-31	0-40
2005	22-28	6-10	30-50	5-10	11-20	30-60
2010	25-32	3-4	50-80	#	#	20-50
2020	29-37	4-5	70-90	#	#	10-30
2030	31-40	2-3	70-90	#	#	10-30

Notes:

\* Range for increases in energy estimates is for class 4 to class 6 sites

<sup>†</sup> Range for contributions represents uncertainty and imprecision from using composite technology assumptions

<sup>‡</sup> Opinions differ on the potential for variable speed to increase energy capture. NREL and others are currently investigating this topic [33]

# Shaded boxes indicate small incremental improvements are possible

Generally, progression in rotor performance, from 1996 into the future, is characterized less by increases in rotor aerodynamic efficiency (peak power, or  $C_p$ ) and more by maintenance of a relatively high efficiency over a larger wind speed range. Additionally, a lower turbine cut-in speed, made possible by larger, variable pitch rotors, is assumed as an advance in 2000 and beyond (the impact of this latter assumption was not evaluated separately). Generator, transmission and power electronics performance, efficiency, are not explicitly modeled, i.e., explicit estimates for these efficiencies are not developed. Currently, these efficiencies are embedded in the curves used to estimate energy output.

Increasing hub height/tower height is shown in Table 6 to be a primary driver of performance gains in 2005. Other first order drivers in 2005 include more efficient variable-speed operation; larger rotors, including aerodynamic rotor control for clipping gusts, which allows larger rotors to be used economically with a given generator rating to capture lower wind speeds; and further reduction of system losses.

Performance gains are expected to level off after 2005, with further improvements assumed to be incremental. Increasing tower height is the primary driver of performance increases during this period. Progress is also expected in areas outside cost and performance. More accurate micrositing models are expected to be developed, which will contribute to a reduction in windfarm array losses. Improvements modeled into the energy estimate calculations for all years include cost/performance tradeoffs including increased tower heights (costs) for improved performance.

**Future Cost:** As seen in Table 7, the major cost changes in 2000 are driven by large increases in the rotor diameter and tower height, elimination of the transmission, and introduction of variable-pitch rotors and new, advanced power electronics for variable-speed operation and power control. Other low cost designs will be present in the market in 2000 -- a doubly-fed generator with a geared transmission is seen as one potential example. Lighter weight, more flexible systems are expected to appear, along with designs aimed at lower cost manufacturing techniques. Changes in specific subsystems include:

## ADVANCED HORIZONTAL AXIS WIND TURBINES IN WINDFARMS

- *Transmission* - While many of the subsystem cost figures are composite values that describe trends, elimination of the geared transmission is a specific design feature that is explicitly assumed because it represents a large source of weight, and therefore offers a substantial cost reduction. This is the only subsystem that becomes a smaller fraction of the total cost for the 2000 system. The reduction from 22% to 7% of total system cost from 1996 to 2000 is based on a recent design study [21] which estimated the transmission to account for 75% of the cost in the "Transmission/Drive Train, Shaft Brakes, Nacelle" category.
- *Towers* - Although savings in tower costs are possible from reduced loads, new tower designs, and advanced materials, total tower costs still increase significantly in 2000 in both per-kW and absolute dollars. This reflects the increase in height as well as increased thrust loads from the larger rotor. Tower cost is assumed to scale linearly with tower height and proportionately with the square of the rotor diameter [34]. However, calculation of the exact percentages of cost increase from each scaling effect, i.e., determination of coefficients in the scaling equation, is beyond the scope of this TC. Nonetheless, the costs in Table 7 are believed to reasonably reflect engineering scaling principles. Peak thrust loads from hurricane or maximum anticipated winds tend to drive tower costs. Since it is assumed that these loads will not be reduced by rotor designs in year 2000, no cost reduction is included to represent the potential for load reduction that may be experienced during normal operation of new variable-speed, variable-geometry rotor systems emerging in year 2000.
- *Rotors* - Table 7 shows an absolute cost increase for the rotor subsystem from \$93,000 to \$135,000 per turbine, reflecting the diameter increase from 38 to 46 meters, and also a trend towards more complex, variable-pitch mechanisms. A percentage of rotor cost increases with the cube of the rotor diameter [34]. As was the case for estimated tower cost increases, scaling coefficients are not developed for this analysis. The trend towards lighter rotors also has a downward influence on costs. The rotor cost, as a percentage of the total system cost, is at the high end of the preliminary estimates from the DOE NGTD Project.
- *Electronics and Controls* - Power and control electronics and other electrical costs show a significant increase in year 2000, as more expensive or more complex electronics are required to implement variable speed, direct drive generation.
- *Generators* - Generator costs are assumed to increase as a result of substituting higher performance technologies for off-the-shelf induction units. Sample technologies might be synchronous or doubly fed generators in 2000.
- *Reliability* - It is assumed that it will be possible to design turbines for incrementally greater reliability based on a better understanding of wind inflow characteristics and how these characteristics impact structural design, and appropriately improved modeling tools. It is expected that there will be improvements in turbine blades, particularly with respect to better integration of blade structural and aerodynamic design with appropriate manufacturing processes. Resulting improvements in reliability are reflected in the decreasing O&M and overhaul/replacement costs.

## ADVANCED HORIZONTAL AXIS WIND TURBINES IN WINDFARMS

Table 7. Cost breakdown for 50 turbine windfarms (January 1996 \$).

Major Subsystems	1996	2000	2005	2010	2020	2030
	\$/kW					
Rotor Assembly (including hub)	185	180	190	160	150	140
Tower	145	145	185	195	215	235
Generator	50	45	55	50	45	40
Electrical/Power Electronics, Controls, Instrumentation	155	140	100	90	75	65
Transmission/Drive Train, Shaft Brakes, Nacelle, Yaw System	215	50	40	35	35	30
Turbine FOB (including profit)	50	560	570	530	520	510
Balance of Station (BOS)	250	190	150	145	135	125
Total Installed Cost (\$/kW)	1,000	750	720	675	655	635
	\$/Turbine (\$thousands)					
Rotor Assembly (including hub)	93	135	190	160	150	140
Tower	73	109	185	195	215	235
Generator	25	34	55	50	45	40
Electrical/Power Electronics, Controls, Instrumentation	78	105	100	90	75	65
Transmission/Drive Train, Shaft Brakes, Nacelle, Yaw System	108	38	40	35	35	30
Turbine FOB (including profit)	375	420	570	530	520	510
Balance of Station (BOS)	125	143	150	145	135	125
Total Installed Cost (\$Thousands/Turbine)	500	563	720	675	655	635
	Percent of Total Initial Project Capital Cost					
Rotor Assembly (including hub)	19	24	26	23	22	22
Tower	15	19	26	28	32	36
Generator	5	6	8	7	7	6
Electrical/Power Electronics, Controls, Instrumentation	16	19	14	14	13	12
Transmission/Drive Train, Shaft Brakes, Nacelle, Yaw System	22	7	6	5	5	5
Turbine FOB (including profit)	75	75	79	78	79	80
Balance of Station (BOS)	25	25	21	22	21	20
Total	100	100	100	100	100	100

Note: "Controls" includes yaw drives and gears. Numbers may not add to 100% due to rounding error.



## ADVANCED HORIZONTAL AXIS WIND TURBINES IN WINDFARMS

The uncertainty bounds on cost in Table 1 are doubled for 2000 and beyond, reflecting the relative difficulty of projecting turbine and project prices. The maximum upper bound for 2000 is assumed to be equal to the lower bound of 1996. This projection is conservative (higher) compared to preliminary estimates from the DOE NGTD Project. The lower bound is also conservative (higher) compared to the lower bound of the NGTD Project estimates.

The key 2005 cost changes are driven by the combined effects of the increase in rotor diameter and tower height. Changes in specific subsystems include:

- *Rotors* - Cost increases from significantly larger diameters in 2005 begin to be offset from improved manufacturing techniques resulting largely from the DOE/industry cost-shared Blade Manufacturing Project and to a lesser extent from increased production. The fact that the total rotor cost does not increase with the cube of the diameter also reflects the increasing use of lower cost paths such as 2-bladed designs, lighter, more flexible structures, or pultruded blades.
- *Electronics* - Cost decreases result primarily from R&D advances in power electronics for variable speed generation systems.
- *Generators* - As in year 2000, generator cost increases, per kW, as a result of a trend toward higher performance technologies such as permanent magnet generators, which may become cost effective in 2005.

Key cost drivers beyond 2005 include:

- *Rotors* - As production volume increases, it is assumed that industry will be able to support larger-scale advanced manufacturing improvements for rotor blades. Also, R&D is assumed to improve the ability to understand the connection between aerodynamic inputs and component fatigue loads, leading to use of lighter, more reliable components, and optimized control systems for lowest-cost approaches. These factors, combined with cost reductions from increased volume, account for the decrease in rotor costs in 2010 and beyond. Because blades are currently a custom-made subsystem, they have the potential to realize larger gains than mature technologies such as steel towers. Therefore, approximately a 10% cost reduction in the custom component of blade cost is expected for every doubling of cumulative production volume [35].
- *Power Electronics and Controls* - Power electronics and controls costs are projected to decrease significantly as a result of technical advances in components through R&D, wind turbine design advances, and increased volume.
- *Generators* - Incremental cost improvements from manufacturing, design, and volume effects are assumed to occur in permanent magnet generators after 2010.
- *Towers* - Cost per kW of towers increases at a rate lower than the tower height increases due to assumed advances in the ability to shed aerodynamic loads and design lighter towers.

The cost shown in Table 1 continues to decrease after 2000 because of three cost drivers: higher volume, advances in manufacturing resulting from R&D efforts, and technology advances from R&D. Therefore, the uncertainty percentage is kept fixed at +20% so that the absolute upper bound, i.e., the actual likely highest cost, is lower for each successive five-year period. The lower bound for 2005 is considered conservative because it is within the range of DOE NGTD Project estimates for 2000 technology cost.

### Effects of Volume on Cost

Although lower costs are not an automatic result of higher sales volume, there are several specific volume effects that reasonably can be expected to lower future turbine and windfarm costs. First, increasing sales may allow the industry to employ new manufacturing technologies that lower production costs. Second, there is an established learning effect in

## ADVANCED HORIZONTAL AXIS WIND TURBINES IN WINDFARMS

similar products that indicates product costs decrease as cumulative sales increase. Third, as annual production volume increases, there may be an opportunity for larger volume discounts for off-the-shelf turbine components. Reference 35 discusses these effects in more depth.

Table 8 summarizes the key qualitative subsystem cost drivers described above.

Table 8. Major subsystem cost drivers.

	1996-2000	2000-2005	2005-2030
Rotor	Increase from larger size Decrease from trend toward lighter designs	Increase from size. Decrease from advanced manufacturing and lighter designs	Incremental reductions from volume, and R&D and manufacturing advances: lighter & smarter rotors
Tower	Largest increase from largest height and rotor size increase	2 <sup>nd</sup> largest increase from height and rotor size increase. Decrease from lighter weight through R&D/design	Incremental increases with height, less than linear due to lighter weight from R&D
Generator	Synchronous or other intermediate, advanced approaches - higher cost than induction generators	First generation low speed permanent magnet - highest cost	Incremental reductions in permanent magnet generator costs from R&D and volume
Electrical	1st generation variable speed is expensive	Major cost drop as technology matures	Incremental improvements from R&D and volume.
Drive Train	Direct drive - no transmission.	Incremental refinements in design approaches	
BOS	Increases from larger turbines and higher power requirements		Incremental from volume

No assumptions were made in this wind TC concerning projected wind energy market penetration since such analysis is beyond the scope of the TC. Instead, this section investigates the level of increased cumulative and annual production volume that would be necessary to achieve the projected cost reductions, after accounting for cost reductions from R&D. The following discussion concludes that the necessary production increases are well within conservative assumptions for industry growth rates and market penetration levels.

Total installed cost per-unit-swept-area in Table 1 decreases 39% from 1996 to 2030. As detailed in Table 8, R&D is expected to reduce costs in all major subsystems between 1996 and 2030. For instance, the stated goal of the DOE Advanced Blade Manufacturing Project is to reduce costs of current blades by 25 percent, which equates to a reduction of 5-6 percent of total cost. Given these expectations, a reasonable estimate for the total percentage of cost reduction expected to be achieved through R&D by 2030 is 25-50%. Therefore, the remainder of the cost reduction, 50-75%, is assumed to be due to volume effects. Using these numbers, a reasonable estimate, relative to expected R&D success, is for R&D to account for a 10-20% cost reduction by 2030 and for volume to account for a 20-30% reduction.

According to reference 35, cost-reduction rates will tend to be higher for turbines with higher percentages of custom-built components versus off-the-shelf components. Assuming future turbine designs contain more custom-built components than current technology, this reference indicates that a reasonable turbine cost reduction rate from volume effects is approximately 5% for each doubling of industry-wide cumulative production. In addition, manufacturers should expect to see volume discounts for non-customized components at a certain level of annual production (reference 35 assumes a baseline estimate of a 10% discount at a level of 1000 units or higher). Finally, the majority of BOS cost reduction after

## ADVANCED HORIZONTAL AXIS WIND TURBINES IN WINDFARMS

2005 is also assumed to be due to volume effects. Given these cost reduction effects from volume, it would take approximately 4-5 doublings of industry-wide cumulative volume to achieve the projected cost reduction between 1996 and 2030.

Cumulative and annual production levels associated with current turbine prices vary widely for current manufacturers. A few manufacturers have produced thousands of cumulative units and have annual production levels up to approximately 500 turbines, while other manufacturers with emerging technology have produced relatively few turbines to date. Given this range as a starting point for cost reduction, 4-5 doublings of cumulative volume by 2030 results in a required range of several thousand to several tens of thousands of turbines by that time. Either of these cumulative levels are within highly conservative assumptions for industry growth and market penetration rates.

### Balance of Station Costs

Balance of Station (BOS) costs include foundations, control/electrical hardware, site preparation, electric collection system and transmission lines, substation, windfarm control and monitoring equipment, O&M facilities and equipment, initial spare parts, shipping, resource assessment, surveying, legal counsel, project management and administration, permits, construction insurance, and engineering services. Since land cost is listed on Table 1 as a percent of revenue and not an initial capital cost, it is discussed in the O&M section.

A range of approximately 25%-33% of total project costs was estimated for BOS costs in a recent design study based on a 50 MW windfarm using 275 kW wind turbines [21]. Other recent estimates are that BOS costs account for approximately 20 percent of the cost of energy from windfarms [20,36]. This indicates that BOS costs are approximately 25% of the total project cost. Therefore, using the TC 1996 FOB cost of \$750/kW yields the BOS value of \$250/kW (250 is 25% of 750+250). The range of +5/-20 shown on Table 1 reflects the possibility that developers may be able to reduce BOS costs for current projects well below the level of \$250/kW [21].

The majority of BOS costs for utility scale windfarm projects are directly dependent on the number of turbines installed. While important, turbine rating has a smaller impact on BOS cost. Since the number of turbines is fixed for all years in this characterization, the primary drivers of BOS cost changes are increases in turbine size in years 2000 and 2005 (BOS cost increases 20% from 1996 to 2005), and from learning effects resulting from increasing cumulative volume after year 2005 (BOS cost decreases by 13% between 2005 and 2030). Learning effects apply to the design, construction and management of projects. The small increase in BOS cost per turbine in years 2000 and 2005 reflects a relatively small amount of additional capacity- and size-related costs, e.g., higher cost power transfer and conditioning equipment, heavier foundations, that are incurred for each turbine. That is, for a 50-turbine windfarm, the absolute cost increases per turbine are small relative to the increase in rated capacity. As expected, the tables show that costs decline significantly on a per-kW basis in both periods.

Project Size Impact on Cost - BOS cost estimates in Table 1 account for costs related to increasing turbine size, and associated increases in per-kW-related costs, for a fixed number of turbines. However, factors to adjust total windfarm project cost for increased numbers of same-size turbines are not included in Table 1. Wind turbines are a modular technology. A wide range of capacity may be installed within a short construction period simply by varying the number of turbines added to an installation. There are two primary sources of potential cost reduction resulting from increasing the number of turbines in a windfarm. First, the manufacturer may be willing to set a lower price for a larger number of turbines. Second, some windfarm costs are fixed or exhibit diminishing costs per turbine for each additional turbine. Examples of these include infrastructure-related costs for roads, grading, and fences, O&M facilities and equipment, project administration and permits, surveying, and legal fees. As a preliminary guide, Table 9 taken from the 1993 EPRI Technical Assessment Guide [37], may be used to scale project costs for various project sizes.

## ADVANCED HORIZONTAL AXIS WIND TURBINES IN WINDFARMS

Table 9. Project size impact on cost.

Plant Size (MW)	Percent of 50 MW Cost
10	120
25	110
50	100
100	95
200	90

### Operation and Maintenance Costs

Annual O&M Costs: Recent industry estimates of O&M cost, including overhauls and replacements, range from \$7,000 to \$10,000/year per turbine [38]. This cost level corresponds to \$0.005-\$0.01/kWh for turbines sizes similar to the 1996 TC turbine and windfarms in the 100 MW range. A recent estimate of \$6,534 (1992 dollars) per turbine per year for 275 kW turbines in a 50 MW windfarm was made under the DOE Near -Term Product Development Project [21]. Annual O&M is often quoted in units of \$/kWh. However, it is difficult to use a single \$/kWh estimate because a large portion of the annual O&M is fixed for each turbine, and the cost per kWh therefore changes depending on the wind resource level and the output of each specific turbine [38,39].

The wind TC 1996 annual O&M cost estimate in dollars per turbine per year is shown in Table 1 with a larger uncertainty on the low side, reflecting the fact that the estimate is on the high end of recent industry estimates. Note also that costs for periodic overhauls and replacement of components are included in some industry estimates, but are contained in a separate figure for the wind TC.

The 2000 and 2005 annual O&M cost estimates are increased to reflect turbine size-related costs for parts, supplies, and equipment. Reference 21 estimates that parts and supplies comprise approximately 70 percent of total O&M. Some of these costs are independent of turbine cost, and some are directly dependent. For this analysis, it is assumed that 50 percent are dependent on the turbine cost. Therefore, 2000 and 2005 annual O&M costs are calculated by adding the following amount to the previous period's cost:

$$70\% \cdot \text{Previous O\&M Cost} + 50\% \cdot \text{Percent Change in Turbine Cost from the Previous Time Period}$$

While higher in cost per turbine, the resulting cost in \$/kWh for year 2000, approximately 0.5 ¢/kWh, is lower than the 1996 figure and is consistent with preliminary data developed under the DOE NGTD Project. Lower annual O&M cost per kWh is a major driver of the trend towards larger turbines. Actual O&M costs, as seen in the market, may not follow a smooth downward trend as shown in the TC. As new turbines are introduced, annual O&M costs may be higher than for previous designs until sufficient experience is developed in the field. Thus, although a downward trend is expected, the actual cost may be "saw-toothed" as new technology is deployed. This can be especially true with a technology in the earlier phases of commercial development, such as wind turbines, when significant improvements are realized with each new generation of technology. Because the uncertainty bounds are already relatively wide for the 1996 estimate in Table 1, no changes were made to those values through 2030.

Beyond 2005, annual O&M costs savings are expected to be realized through simplification of design, such as the elimination of hydraulic systems for brakes and/or blade pitch mechanisms, and through optimization of O&M practices. This trend is reflected in the decreasing trajectory presented in Table 1.

## ADVANCED HORIZONTAL AXIS WIND TURBINES IN WINDFARMS

Overhauls and Replacement Costs: These costs include periodic major component replacements and overhauls. For 1996, repairs include gearbox overhaul and generator bearing replacement in years 10 and 20 at a cost of 5% of total installed cost, and replacement of the blades in year 20 at a cost of 10% of total installed cost [21]. Major replacement/overhaul costs are estimated to be on the same schedule in year 2000 because uncertainty with scaled-up design is assumed to be offset by increased resistance to fatigue from composite rotor materials and/or improved design ability. As more experience is gained with these larger designs and newer materials, replacement costs fall to 5% and 10% of total cost in years 10 and 20, respectively, for the 2010 turbine (2005 assumes a linear interpolation between 2000 and 2010). Costs fall to 5% and 5% in years 10 and 20, respectively, for the 2020 and 2030 turbines. The impact of these costs on COE varies for different ownership/financing assumptions and wind resource levels. For investor-owned utility assumptions, the effect ranges from 0.3 to 0.5 ¢/kWh in 1996, and from 0.1 to 0.2 ¢/kWh in 2030.

These estimates are based on engineering judgement concerning the projected impact of improved design codes coupled with an improved understanding of fatigue-failure modes. Overhaul and replacement costs have a large uncertainty associated with them, reflecting a wide range of estimates, including detailed engineering cost studies [21] and manufacturer claims that turbines are designed to avoid major periodic repairs [20,38]. Compared to the average of these estimates, the value in Table 1 is judged to be conservative and therefore has a larger uncertainty on the negative side. This large uncertainty is carried through the time periods, reflecting the potential for lower costs (higher durability) than those portrayed in the table. In the actual market, a tradeoff exists between initial turbine cost and design lifetime of turbine components. This composite characterization is believed to reflect a middle ground relative to this tradeoff.

Land Costs: While costs for land lease or purchase will vary for individual projects, the value in Table 1 assumes land is leased using royalty payments and is on the high end of the range quoted for current projects [25,40,41]. Regional variations in land availability may alter land costs. Estimates of regional land cost variations have not been made for this analysis. There will be different influences on land lease values in the future. The dominant influence is that larger and more advanced turbines will produce more revenues per unit of land. Therefore, land owners will tend to realize much larger revenues from land leases, perhaps giving developers the ability to bargain the percentage down. The large uncertainties associated with land lease costs in Table 1 reflects the fact that it is unclear how costs will change over time, and that there is always a range of costs associated with different parcels of land.

### Uncertainty

Uncertainty reflected in the +/- ranges in Table 1 comes from two sources. The first is the uncertainty associated with the accuracy of the value, e.g., uncertainty of outcome of R&D. The second is from the normal variation in data values for projects, such as the cost of land for different projects.

### Reliability

Reliability and durability are reflected quantitatively in several ways in this characterization. First, availability is already at high levels for given current initial turbine cost, O&M cost, and system lifetime. Second, the decline of annual O&M costs after 2005 reflects increased reliability. The decline in per-kWh O&M costs between 1996 and 2005 is assumed to be due more to increased energy output per turbine than increased levels of reliability. This is a conservative assumption, since R&D is expected to result in more reliable systems in this time frame as well. Third, major overhauls and replacement costs decrease over time, reflecting an increase in durability and maintenance intervals for each period's stated initial capital cost level. Finally, the reductions in initial capital cost for the same size turbine and same assumed turbine lifetime after year 2005 reflect the expected trend towards increased lifetime/cost ratios made possible by R&D.

## ADVANCED HORIZONTAL AXIS WIND TURBINES IN WINDFARMS

### Other Areas of Value

In the long-term, progress is also expected in areas outside of cost and performance of the individual turbine and the windfarm as a whole. For example, better local weather forecasting, along with appropriate system operator training, is expected to raise the value of wind energy.

### 5.0 Land, Water, and Critical Materials Requirements

As demonstrated in Table 10, the amount of land required for windfarms depends on turbine size and number, turbine spacing (distance side-by-side and between rows), and the number of rows. The range of land use per MW of installed capacity in Table 10 covers two scenarios for turbine spacing: 2.5 rotor diameters (side-by-side) by 20 diameters between rows, and 5 diameters (side-by-side) by 10 diameters between rows. These ranges are shown for three array configurations of 5 rows of 10 turbines (more common in flat areas), 2 rows of 25 turbines, and a single row of 50 turbines (more common on ridged sites). A setback of 5 rotor diameters is assumed around the perimeter of the windfarm. While these scenarios represent a range of possible configurations for a 50 turbine windfarm, actual project configurations will be site specific, depending on terrain, local wind characteristics ("micrositing conditions"), turbine characteristics, environmental and aesthetic considerations, and cost and availability of land. The trend towards lower land use per unit of capacity in later years is due to the increasing rating of the composite turbines described in this characterization.

Land: Land does not have to be purchased/leased and dedicated exclusively for wind energy production. Approximately 5-10% of a windfarm's land area is actually utilized by wind turbines, leaving the majority free for other compatible uses. Leases are quite common where co-uses such as livestock grazing reduce the cost to the windfarm owner while increasing the land value to the land owner. Another possibility is to use former agricultural lands designated under the soil conservation program to enhance the fixed per-acre revenues allowed by the government.

Water: As shown in Table 10, windfarms have no water requirement for operation. This is advantageous in areas where competition for water is important.

Table 10. Resource requirements.

Indicator Name	Units	Base Year					
		1996	2000	2005	2010	2020	2030
WindFarm Size	MW	25	37.5	50	50	50	50
Land (50 turbines)							
5 turbines x 10 rows	ha/MW	33-20	26-16	24-15	24-15	24-15	24-15
	ha	825-500	975-600	1200-750	1200-750	1200-750	1200-750
25 turbines x 2 rows	ha/MW	19-26	15-21	14-19	14-19	14-19	14-19
	ha	475-650	563-788	700-950	700-950	700-950	700-950
50 turbines x 1 row	ha/MW	29-46	23-37	21-33	21-33	21-33	21-33
	ha	725-1150	863-1388	1050-1650	1050-1650	1050-1650	1050-1650
Water	m <sup>3</sup>	0	0	0	0	0	0

Note: Range is for 2.5 rotor diameters (side) by 20 diameters (deep), and 5 diameters (side) by 10 diameters (deep)

## ADVANCED HORIZONTAL AXIS WIND TURBINES IN WINDFARMS

### 6.0 References

1. Milligan, M., "Variance Estimates of Wind Plant Capacity Credit," Windpower '96 Proceedings, American Wind Energy Association, June 23-27, 1996, pp. 313-332.
2. Grubb, Michael, "Valuing Wind Energy on a Utility Grid", Parts 1-3, Wind Energy Weekly, Vol 27, No. 350-351, pp. 4-9, No. 352, pp. 4-9, No. 353, pp 4-9. First published in Windirections.
3. Halberg, N., "Wind Energy Research Activities of the Dutch Electricity Generating Board" Proceedings of the European Community Wind Energy Conference, Madrid, Spain (September 1990).
4. "The Potential of Renewable Energy, An Interlaboratory White Paper," March, 1990, pg. 36, SERI/TP-260-3674.
5. Wan, Y., and B.K. Parsons, Factors Relevant to Utility Integration of Intermittent Renewable Technologies, National Renewable Energy Laboratory, Golden, CO: August, 1993. Report NREL/TP-463-4953.
6. Elliott, D.L., L.L. Wendell, and G.L. Gower, An Assessment of the Available Windy Land Area and Wind Energy Potential in the Contiguous United States, Pacific Northwest Laboratory: August, 1991. Report PNL-7789.
7. Elliott, D.L. et. al., Wind Energy Resource Atlas of the United States, Pacific Northwest Laboratory, for the U.S. Department of Energy: October, 1986. Report DOE/CH 10093-4.
8. Brower, et. al., "Powering the Midwest: Renewable Energy for the Economy and the Environment," Union of Concerned Scientists, Cambridge, MA, 1993.
9. Parsons, B., E. Hammond, and Y. Wan, U.S. Wind Reserves Accessible to Transmission Lines, National Renewable Energy Laboratory: 1995.
10. Technical Assessment Guide, Volume 3: Fundamentals and Methods, Electricity Supply, Electric Power Research Institute, V3, R6, (diskette), 1992. Report TR-100281.
11. FATE-2P cashflow model, Princeton Economic Research, Inc., Rockville, MD, developed for the National Renewable Energy Laboratory, 1997.
12. "Harvest the Wind....", Sustainable Resources Center, Part of the Windustry™ Wind Energy Course, Minneapolis, Minnesota, 1997.
13. Planning Your First Windpower Project: a Primer for Utilities, Electric Power Research Institute, Palo Alto, CA: 1994. Report TR-104398.
14. Avery, M.L., P.F. Springer, and N.S. Dailey, Avian Mortality and Man-made Structures: an Annotated Bibliography (Revised), United States Fish & Wildlife Service: 1980. Report OBS-80/54.
15. Colson, E.W., "Avian Interactions with Wind Energy Facilities: A Summary," Windpower '95 Proceedings, American Wind Energy Association, March 26-30, 1995, pp. 77-86.

## ADVANCED HORIZONTAL AXIS WIND TURBINES IN WINDFARMS

16. Wind Resource Assessment Handbook, AWS Scientific, Inc., for the National Renewable Energy Laboratory: 1997. Report NREL SR-440-22223.
17. Thresher, R., Proceedings of Utility Wind Interest Group (UWIG) Technical Workshop, August 13, 1996.
18. "Three Companies Selected For Major Wind Energy Research Project," National Renewable Energy Laboratory, Golden, CO, January 13, 1996.
19. Robinson, M., "National Wind Technology Center (NWTC) Research Facilities and Objectives," Briefing at IEA Wind Experts Meeting (October 1995).
20. Gates, R., Oral presentation at Utility Wind Interest Group Technical Workshop, Minneapolis, MN (August 13, 1996).
21. Advanced Wind Turbine Conceptual Study, Final Report, August 1990 - March 1992, R. Lynette & Associates: July 1995. Report NREL/TP-441-692.
22. Advanced Wind Turbine Near-Term Product Development, Final Technical Report, R. Lynette & Associates: January, 1996. Report NREL/TP-441-7229.
23. Advanced Wind Turbine Design Studies, Northern Power System: November 1992.
24. Manufacturer Product Literature from Cannon/Wind Eagle Corporation, Kenetech, Vestas, Zond, Enercon, Bonus, Micon, Tacke, and others.
25. "Wind Power Economics," Zond Energy Systems, Inc. presentation at "Opportunities for Finance and Investment in Wind Energy," New York, NY (November, 1994).
26. WindScan User's Guide, Princeton Economic Research, Inc., for the National Renewable Energy Laboratory: October, 1996.
27. Carlin, P.W., "Analytic Expressions for Maximum Wind Turbine Average Power in a Rayleigh Wind Regime," Proceedings of 1997 ASME Wind Energy Symposium at the 35th AIAA Aerospace Sciences Meeting (January 6-9, 1997).
28. Tangler, J.L. and D.M. Somers, "NREL Airfoil Families for HAWTs", Windpower '95 Proceedings, American Wind Energy Association, Washington D.C., March 26-30, 1995, pp. 117-128.
29. Tangler, J.L., "Influence of Pitch, Twist, and Taper on a Blades' Performance Loss Due to Roughness", Windpower '96 Proceedings, American Wind Energy Association, Denver, Colorado, June 23-27, 1996, pp. 547-556.
30. "Wind Turbine Market - Types, Technical Characteristics, Prices, The International Overview, 1996," WINKRA-PROJECT GmbH, WINKRA-RECOM Messe- und Verlags-GmbH.
31. Tennis, M.W., and M.C. Brower, "Powering the Midwest: Wind Energy," WindPower '93 Proceedings, American Wind Energy Association, July 12-16, 1993, pp. 183-190.



## **ADVANCED HORIZONTAL AXIS WIND TURBINES IN WINDFARMS**

32. Communication with Cannon Wind Eagle, January 1996.
33. Fingerish, L., and Robinson, M., "The Effects of Variable Speed and Drive Train Component Efficiencies on Wind Turbine Energy Capture," Proceedings of 1997 ASME Wind Energy Symposium at the 35th AIAA Aerospace Sciences Meeting (January 6-9, 1997).
34. Holley, W., W. Aitkenhead, G. McNemey, and E. Rogers, "Estimating A Wind Turbine Rotor Diameter To Minimize The Installed Cost Of Energy," U.S. Windpower, Inc., and Jet Stream.
35. The Effects of Increased Production on Wind Turbine Costs, Draft, Princeton Economic Research, Inc., for the National Renewable Energy Laboratory: December 21, 1995.
36. Holley, W., Oral presentation at Windpower '97, Austin Texas (June 15-18, 1997).
37. Technical Assessment Guide, Electricity Supply-1993, Electric Power Research Institute, Volume 1: Rev. 7, June 1993. Report EPRI TR-102276-V1R7.
38. Industry O&M Panel at the Utility Wind Interest Group Technical Workshop, August 14, 1996. Also published in "Wind Watch," Vol. 1, No. 3, September, 1996.
39. Bone, D., "Wind Energy on the Southern California Edison System," Proceedings of the UWIG Technical Workshop, Minneapolis, MN, August 14, 1996, pg. 4.
40. Private communication with windfarm developer, 1992.
41. Wind, T.A., "Wind Farm Feasibility Study for the Iowa Association of Municipal Utilities," April 1996.

# PROJECT FINANCIAL EVALUATION

## Introduction to Financial Figures of Merit

An investor, energy policy analyst, or developer may use a variety of figures of merit to evaluate the financial attractiveness of a power project. The choice often depends on the purpose of the analysis. However, most begin with estimates of the project's capital cost, projected power output, and annual revenues, expenses, and deductions. A pro forma earnings statement, debt redemption schedule, and statement of after-tax cash flows are typically also prepared. Annual after-tax cash flows are then compared to initial equity investment to determine available return. For another perspective, before-tax, no-debt cash flows may also be calculated and compared to the project's total cost. The four primary figures of merit are:

**Net Present Value:** Net Present Value (NPV) is the sum of all years' discounted after-tax cash flows. The NPV method is a valuable indicator because it recognizes the time value of money. Projects whose returns show positive NPVs are attractive.

**Internal Rate of Return:** Internal rate of return (IRR) is defined as the discount rate at which the after-tax NPV is zero. The calculated IRR is examined to determine if it exceeds a minimally acceptable return, often called the hurdle rate. The advantage of IRR is that, unlike NPV, its percentage results allow projects of vastly different sizes to be easily compared.

**Cost of Energy:** To calculate a levelized cost of energy (COE), the revenue stream of an energy project is discounted using a standard rate (or possibly the project's IRR) to yield an NPV. This NPV is levelized to an annual payment and then divided by the project's annual energy output to yield a value in cents per kWh. The COE is often used by energy policy analysts and project evaluators to develop first-order assessments of a project's attractiveness. The levelized COE defines the stream of revenues that minimally meets the requirements for equity return and minimum debt coverage ratio. Traditional utility revenue requirement analyses are cost-based, i.e., allowed costs, expenses, and returns are added to find a stream of revenues that meet the return criteria. Market-based Independent Power Producer (IPP) and Generating Company (GenCo) analyses require trial-and-error testing to find the revenues that meet debt coverage and equity return standards, but their COEs likewise provide useful information.

**Payback Period:** A payback calculation compares revenues with costs and determines the length of time required to recoup the initial investment. A Simple Payback Period is often calculated without regard to the time value of money. This figure of merit is frequently used to analyze retrofit opportunities offering incremental benefits and end-user applications.

## Financial Structures

Four distinct ownership perspectives were identified for this analysis. Each reflects a different financial structure, financing costs, taxes, and desired rates of return. Briefly, the four ownership scenarios are:

**Generating Company (GenCo):** The GenCo takes a market-based rate of return approach to building, owning, and operating a power plant. The company uses balance-sheet or corporate finance, where debt and equity investors hold claim to a diversified pool of corporate assets. For this reason, GenCo debt and equity are less risky than for an IPP (see below) and therefore GenCos pay lower returns. A typical GenCo capital structure consists of 35% debt at a 7.5% annual return (with no debt service reserve or letter of credit required) and 65% equity at 13% return. Although corporate finance might assume the debt to equity ratio remains constant over the project's life and principal is never repaid, it is often informative to explicitly show the effect of the project on a stand-alone

## PROJECT FINANCIAL EVALUATION

financial basis. Therefore, to be conservative, the debt term is estimated as 28 years for a 30-year project, and all the debt is repaid assuming level mortgage-style payments. Flow-through accounting is used so that the corporate GenCo receives maximum benefit from accelerated depreciation and tax credits.

Independent Power Producer (IPP): An IPP's debt and equity investment is secured by only the one project, not by a pool of projects or other corporate assets as is the case for a GenCo. In this project finance approach, a typical capital structure is 70% debt at 8.0% annual return (based on 30-year Treasury Bill return plus a 1.5% spread) and 30% equity at a minimum 17% return. A 6-month Debt Service Reserve is maintained to limit repayment risks. Debt term for an IPP project is generally 15 years, with a level mortgage-style debt repayment schedule. (For solar and geothermal projects that are entitled to take Investment Tax Credits, a capital structure of 60% debt and 40% equity should be considered.) Flow-through accounting is used to allow equity investors to realize maximum benefit from accelerated depreciation and tax credits. IPP projects are required to meet two minimum debt coverage ratios. The first requirement is to have an operating income of no less than 1.5 times the annual debt service for the worst year. The second is to have an operating income of about 1.8 times or better for the average year. Because debt coverage is often the tightest constraint, actual IRR may be well over 17%, to perhaps 20% or more. Likewise, with good debt coverage, negative after-tax cash flows in later years of debt repayment (phantom income) are low.

Regulated Investor-Owned Utility (IOU): The regulated IOU perspective analyzes a project with a cost-based revenue requirements approach. As described by the EPRI Technical Assessment Guide (TAG™), returns on investment are not set by the market, but by the regulatory system. In this calculation, operating expenses, property taxes, insurance, depreciation, and returns are summed to determine the revenue stream necessary to provide the approved return to debt and equity investors. Use of a Fixed Charge Rate is a way to approximate the levelized COE from this perspective. IOU capital structure is estimated as 47% debt at a 7.5% annual return; 6% preferred stock at 7.2%; and 47% common stock at 12.0%. Debt term and project life are both 30 years. Accelerated depreciation is normalized using a deferred tax account to spread the result over the project's lifetime. IOUs are not eligible to take an Investment Tax Credit for either solar or geothermal projects.

Municipal Utility (or other tax-exempt utility): The municipal utility uses an analysis approach similar to that of the IOU. Capital structure is, however, assumed to be 100% debt at 5.5% annual return, and the public utility pays neither income tax nor property tax.

### Techniques for Calculating Levelized COE

The technique to be used for calculating levelized COE varies with ownership perspective. Two of the four ownership perspectives (IOU and Muni) employ a cost-based revenue requirements approach, while the other two use a market-based rate of return approach. The revenue requirements approach assumes a utility has a franchised service territory and, its rate of return is set by the state regulatory agency. The plant's annual expenses and cash charges are added to the allowed rate of return on the capital investment to determine revenues.

By contrast, the market-based approach (GenCo and IPP) either estimates a stream of project revenues from projections about electricity sales prices or proposes a stream as part of a competitive bid. Annual project expenses, including financing costs, are calculated and subtracted from revenues and an IRR is then calculated. The process of calculating the achieved IRR differs from the revenue requirements approach where the rate of return is pre-determined.

## PROJECT FINANCIAL EVALUATION

COEs can be calculated for both revenue requirements and rate of return approaches. When pro forma cash flows in dollars of the day are projected for both approaches, the effects of general inflation are captured in debt repayment, income taxes, and other factors. Next, revenues are net present valued in current dollars. The NPV is then leveled to current dollars and/or constant dollars using appropriate discount rates for each. These are then leveled and normalized to one unit of energy production (kWh) to calculate current and constant dollar COEs. This document cites leveled constant dollar COEs in 1997 dollars.

Table 1 provides an example of the results that may be obtained for the technologies characterized in this document. The table shows leveled COE for the various renewable energy technologies assuming GenCo ownership and balance sheet finance.

Table 1. Levelized Cost of Energy for GenCo Ownership

		Levelized COE <i>(constant 1997 cents/kWh)</i>				
Technology	Configuration	1997	2000	2010	2020	2030
Dispatchable Technologies						
Biomass	Direct-Fired	8.7	7.5	7.0	5.8	5.8
	Gasification-Based	7.3	6.7	6.1	5.4	5.0
Geothermal	Hydrothermal Flash	3.3	3.0	2.4	2.1	2.0
	Hydrothermal Binary	3.9	3.6	2.9	2.7	2.5
	Hot Dry Rock	10.9	10.1	8.3	6.5	5.3
Solar Thermal	Power Tower	--	13.6*	5.2	4.2	4.2
	Parabolic Trough	17.3	11.8	7.6	7.2	6.8
	Dish Engine -- Hybrid	--	17.9	6.1	5.5	5.2
Intermittent Technologies						
Photovoltaics	Utility-Scale Flat-Plate Thin Film	51.7	29.0	8.1	6.2	5.0
	Concentrators	49.1	24.4	9.4	6.5	5.3
	Utility-Owned Residential (Neighborhood)	37.0	29.7	17.0	10.2	6.2
Solar Thermal	Dish Engine (solar-only configuration)	134.3	26.8	7.2	6.4	5.9
Wind	Advanced Horizontal Axis Turbines					
	- Class 4 wind regime	6.4	4.3	3.1	2.9	2.8
	- Class 6 wind regime	5.0	3.4	2.5	2.4	2.3

\* COE is only for the solar portion of the year 2000 hybrid plant configuration.

## PROJECT FINANCIAL EVALUATION

### Financial Model and Results

The FATE2-P (Financial Analysis Tool for Electric Energy Projects) financial analysis model was used to analyze the data provided in the Technology Characterizations. This spreadsheet model was developed by Princeton Economic Research, Inc. and the National Renewable Energy Laboratory for the U.S. Department of Energy. FATE2-P can be used for either the revenue requirements or the discounted rate of return approach. It is used by the DOE renewable energy R&D programs for its planning activities. The model is publicly available, and has been used by a number of non-DOE analysts in recent studies. Other models will produce the same results given the same inputs.

The COEs in Table 1 were prepared using the FATE2-P model, assuming GenCo ownership. The results reflect a capital structure of 35% debt with a 7.5% return (with no debt service reserve or letter of credit required) and 65% equity at 13%. A 40% tax rate is assumed. Inflation was estimated at 3%, but electricity sales revenues were assumed to increase at inflation less one half percent, or 2.5%, corresponding to a real rate of -0.5%. In similar fashion, the Department of Energy's Annual Energy Outlook 1997 forecasts that retail electricity prices will decline by 0.6% real, assuming inflation of 3.1%. Anecdotal information from IPPs suggests that they also presently escalate their wholesale power prices at less than inflation.

Table 1 distinguishes between dispatchable and intermittent technologies to highlight the different services and value that each brings to the grid. COEs from the two types of services should not generally be compared.

By comparison, Table 2 shows COEs for year 2000 biomass gasification, to show how the financial requirements of the different ownership perspectives affect COE. The GenCo case is interesting to examine because it represents an evolving power plant ownership paradigm. The municipal utility (Muni) case is of interest because the lower cost of capital for Munis, combined with their tax-exempt status, makes them attractive early market opportunities for renewable energy systems.

As discussed, calculating a levelized COE in the GenCo and IPP cases requires an iterative process. In this process, the goal is to identify the stream of revenues that is needed to ensure the project some minimally acceptable rate of return. This revenue stream is found by adjusting the assumption about first year energy payment (often termed the bid price) until the resulting total project revenues produce the required rate of return subject to meeting debt coverage requirements and minimizing phantom income for IPPs, and to meeting minimum equity returns for GenCos. In the analyses discussed here, the energy sales revenues are assumed to increase through the entire project life only at the rate of inflation minus one half percent (2.5%).

A few common assumptions underlie all the ownership/financing types. First, COE results are expressed in levelized constant 1997 dollars, consistent with the cost data in each TC, that are also stated in 1997 dollars. Second, general inflation is estimated at 3% per year, so annual expenses like operations and maintenance (O&M) and insurance escalate at 3% per year despite the fact that IPP and GenCo revenues increase at only 2.5%. Inflation also affects the values chosen for interest rates and equity returns. Tax calculations reflect an assumed 40% combined corporate rate (i.e.,

Table 2. Cost of Energy For Various Ownership Cases for Biomass Gasification in Year 2000

Financial Structure	Levelized Cost of Energy (constant 1997 cents/kWh)
GenCo	6.65
IPP	7.33
IOU	6.39
Muni	5.09

## PROJECT FINANCIAL EVALUATION

### Tax Policy Analyses: An Example Use of Financial Modeling

The effect of the tax code on the relative attractiveness of various electricity generating options can be analyzed by a financial model such as FATE2-P. A frequently mentioned goal of tax policy is to provide a “level playing field” for all technology options. One study, summarized in the figure, has shown that capital-intensive power projects, such as parabolic trough plants, pay a higher percentage of taxes than operating expense-intensive projects, such as fossil fuel technologies (through property taxes, sales taxes, etc.). Changes to the tax code have been suggested as a way to remove this potential bias.

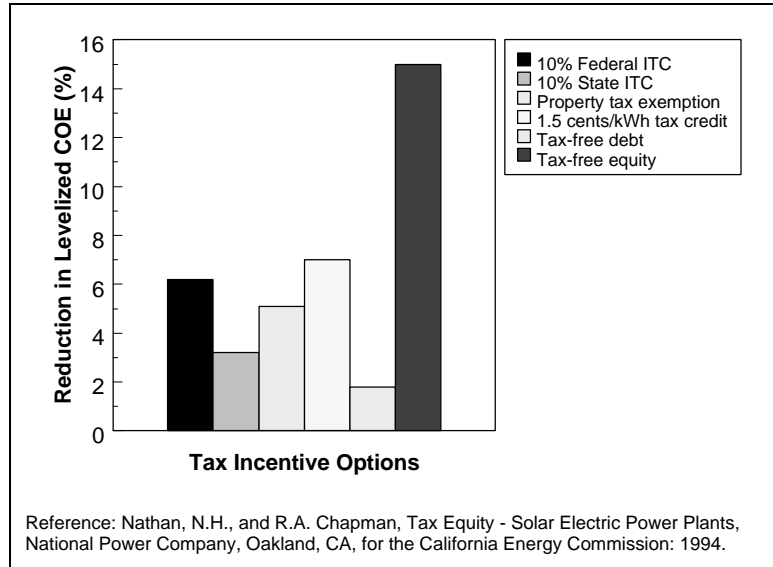

The graph shows the reduction in levelized energy cost for a number of possible tax system-based incentives. The 10% federal investment tax credit currently exists. The study cited in the figure compared taxes paid by solar thermal electric and fossil technologies. The analysis showed that approximate tax equity was achieved with a 20% federal investment tax credit and solar property tax exemption. Overall, this reduces levelized cost of energy by 20-30%. Although these results apply to the specific case tested, it shows the approximate level of tax incentives necessary to gain parity between solar thermal and conventional technologies. Since tax codes vary by state, each state could have a unique mix of additional tax incentives to provide incentives for solar for their unique tax environment.

federal at 35% and state at 7.7%, with state deductible from federal). In addition, depreciation periods and rates are those set by current law. Tax credits were used if set by law as permanent as of November 1997. Thus, the 10% Investment Tax Credit for solar and geothermal is included, but not the production tax credits for wind or closed loop biomass that are not available after mid-1999.

For the solar, dish hybrid cases and the early solar trough hybrid cases, the analyses in Table 1 assumed that natural gas costs \$2.25/MMBtu in 1997 dollars and that it would escalate at 3% per year, equivalent to the inflation rate. The heat rate for the dish system was assumed to be 11,000 Btu/kWh in 2000 and 9000 Btu/kWh in 2005 and later. The trough TC included a heat rate in its hybrid system characterization.

### **Payback Period**

For co-fired biomass a simple payback period was calculated instead of a levelized COE. As a retrofit opportunity, co-firing will be pursued by plant owners only if paybacks of a few years can be achieved. Simple Payback is defined as total capital investment divided by annual energy savings, to obtain years until payback. In simple payback, no consideration is given to the time value of money and no discount rates are applied to dollar values in future years. In the co-fire analyses, the simple payback is defined by comparing capital expenditures required for the retrofit with fuel cost and other savings. As an example, the technology described in the biomass co-fire technology characterization yields a 4.1-year payback in 2000.

**Appendix A:**

**ENERGY STORAGE TECHNOLOGIES**

# OVERVIEW OF ENERGY STORAGE TECHNOLOGIES

## Introduction

The U.S. electric utility industry is in the process of revolutionary change, from impending restructuring and competition, to limitations on installing new conventional generation and transmission and distribution equipment. The current situation in the electricity market may offer unique opportunities for energy storage technologies, particularly in combination with renewable energy generation, in which a few seconds to a few hours of electricity can be held for use at a later time [1,2]. These systems can be located near the generator, transmission line, distribution substation, or the consumer, depending on the application they are addressing.

Storage can play a flexible, multi-function role in the electricity supply network to manage resources effectively. As a generation resource, energy storage can provide savings in operating costs [3,4] or capital expenditures. Examples are: (a) spinning reserve for temporary generation backup, (b) frequency regulation for isolated utilities to maintain 60 Hz, and (c) capacity deferral of new generating facilities. In November 1994, the Puerto Rico Electric Power Authority installed a 20 MW/40-minute battery energy storage system for frequency and voltage regulation and spinning reserve [5]. The unit is dispatched just as any other generation resource in their system and the battery has reduced the impact of outages and improved reliability of electric service.

In combination with renewable resources, energy storage can increase the value of photovoltaic (PV) and wind-generated electricity, by making supply coincident with periods of peak consumer demand [6,7]. Energy storage may facilitate large-scale integration of intermittent renewable resources such as wind and solar onto the electric grid [8,9]. Energy storage systems complement renewable resources with siting flexibility and minimal environmental impacts.

Strategically-placed storage systems can increase the utilization of existing transmission and distribution (T&D) equipment and defer or eliminate the need for costly T&D additions [10-14]. Energy storage can be used to reduce the stress on individual transmission lines that are near peak rating by reducing substation peak load. Among specific T&D benefits are (a) transmission line stability for synchronous operation to prevent system collapse (b) voltage regulation for consistent voltage within 5% of set point, and (c) deferral of construction or upgrade of T&D lines, transformers, capacitor banks, and substations. Opportunities may develop for Independent System Operators to deploy storage to help balance regional loads as restructuring proceeds [1].

Energy storage can serve customers as a controllable demand-side management option that can also provide premium services, including (a) power quality for sags or surges lasting less than 5 seconds, (b) uninterruptible power supply for outages lasting about 10 minutes, and (c) peak demand reduction to reduce electricity bills.

A power quality problem is any voltage, current, or frequency deviation that results in the failure or misoperation of customer equipment. It can be a surge that lasts a few cycles (less than a second) or an outage that continues for hours, ongoing harmonic distortion or intermittent voltage flicker. A survey of 450 information systems executives at Fortune 1000 companies revealed that power quality problems resulted in significant computer crashes and productivity losses that are estimated to cost U.S. businesses \$400 billion each year [15]. Power quality storage systems correct the problem in the first cycle and can be sized to provide a few seconds or minutes of protection.

Finally, energy storage is commonly used in stand-alone applications, where it can serve as an uninterruptible power supply (UPS) unit. UPS units are used for back-up power and only activate in cases of power outages unlike the energy storage systems discussed herein that perform a number of on-line applications. Isolated, remote locations, without connection to electricity grids, must consider some type of back-up power if an intermittent source is used. There are many examples of battery energy storage integrated with PV and wind facilities at national parks and military installations [8,9,16-19].



## OVERVIEW OF ENERGY STORAGE TECHNOLOGIES

### Electric Storage Technologies

A number of energy storage technologies have been developed or are under development for electric power applications, including:

- Pumped hydropower
- Compressed air energy storage (CAES)
- Batteries
- Flywheels
- Superconducting magnetic energy storage (SMES)
- Supercapacitors

Thermal energy storage technologies, such as molten salt, are not addressed in this appendix.

**Pumped Hydro:** Pumped hydro has been in use since 1929, making it the oldest of the central station energy storage technologies. In fact, until 1970 it was the only commercially available storage option for generation applications. Conventional pumped hydro facilities consist of two large reservoirs, one is located at base level and the other is situated at a different elevation. Water is pumped to the upper reservoir where it can be stored as potential energy. Upon demand, water is released back into the lower reservoir, passing through hydraulic turbines which generate electrical power as high as 1,000 MW. The barriers to increased use of this storage technology in the U.S. include high construction costs and long lead times as well as the geographic, geologic and environmental constraints associated with reservoir design. Currently, efforts aimed at increasing the use of pumped hydro storage are focused on the development of underground facilities [20].

**Compressed Air Energy Storage (CAES):** CAES plants use off-peak energy to compress and store air in an air-tight underground storage cavern. Upon demand, stored air is released from the cavern, heated and expanded through a combustion turbine to create electrical energy. In 1991, the first U.S. CAES facility was built in McIntosh, Alabama, by the Alabama Electric Cooperative and EPRI, and has a capacity rating of 110 MW. Currently, manufacturers can create CAES machinery for facilities ranging from 5 to 350 MW. EPRI has estimated that more than 85% of the U.S. has geological characteristics that will accommodate an underground CAES reservoir [21]. Studies have concluded that CAES is competitive with combustion turbines and combined-cycle units, even without attributing some of the unique benefits of energy storage [22].

**Batteries:** In recent years, much of the focus in the development of electric energy storage technology has been centered on battery storage devices. There are currently a wide variety of batteries available commercially and many more in the design phase. In a chemical battery, charging causes reactions in electrochemical compounds to store energy from a generator in a chemical form. Upon demand, reverse chemical reactions cause electricity to flow out of the battery and back to the grid. The first commercially available battery was the flooded lead-acid battery which was used for fixed, centralized applications. The valve-regulated lead-acid (VRLA) battery is the latest commercially available option. The VRLA battery is low-maintenance, spill- and leak-proof, and relatively compact. Zinc/bromine is a newer battery storage technology that has not yet reached the commercial market. Other lithium-based batteries are under development. Batteries are manufactured in a wide variety of capacities ranging from less than 100 watt hours to modular configurations of several megawatts. As a result, batteries can be used for various utility applications in the areas of generation, T&D, and customer service.

**Flywheels:** Flywheels are currently being used for a number of non-utility related applications. Recently, however, researchers have begun to explore utility energy storage applications. A flywheel storage device consists of a flywheel that spins at a very high velocity and an integrated electrical apparatus that can operate either as a motor to turn the

## OVERVIEW OF ENERGY STORAGE TECHNOLOGIES

flywheel and store energy or as a generator to produce electrical power on demand using the energy stored in the flywheel. The use of magnetic bearings and a vacuum chamber helps reduce energy losses. A proper match between geometry and material characteristics influences optimal wheel design. As a result, engineers have focused on the development of materials with high working strength-to-density ratios. Flywheels have been proposed to improve the range, performance and energy efficiency of electric vehicles. Development of flywheels for utilities has been focused on power quality applications [20,23].

**Superconducting Magnetic Energy Storage (SMES):** A SMES system stores energy in the magnetic field created by the flow of direct current in a coil of superconducting material. To maintain the coil in its superconducting state, it is immersed in liquid helium contained in a vacuum-insulated cryostat. The energy output of a SMES system is much less dependent on the discharge rate than batteries. SMES systems also have a high cycle life and, as a result, are suitable for applications that require constant, full cycling and a continuous mode of operation. Although research is being conducted on larger SMES systems in the range of 10 to 100 MW, recent focus has been on the smaller micro-SMES devices in the range of 1 to 10 MW. Micro-SMES devices are available commercially for power quality applications [20,22,23].

**Advanced Electrochemical Capacitors:** Supercapacitors (also known as ultracapacitors or supercapacitors) are in the earliest stages of development as an energy storage technology for electric utility applications. An electrochemical capacitor has components related to both a battery and a capacitor. Consequently, cell voltage is limited to a few volts. Specifically, the charge is stored by ions as in a battery. But, as in a conventional capacitor, no chemical reaction takes place in energy delivery. An electrochemical capacitor consists of two oppositely charged electrodes, a separator, electrolyte and current collectors. Presently, very small supercapacitors in the range of seven to ten watts are widely available commercially for consumer power quality applications and are commonly found in household electrical devices. Development of larger-scale capacitors has been focused on electric vehicles [24]. Currently, small-scale power quality (<250 kW) is considered to be the most promising utility use for advanced capacitors.

Table 1 summarizes the key features of each energy storage system. Batteries, flywheels, SMES and advanced electrochemical capacitors lend themselves to distributed utility applications while pumped hydro and CAES are large, centralized installations. All cost estimates are for complete systems with power conditioning subsystems (PCS), controls, ventilation and cooling, facility, and other balance of plant components.

### Research & Development

The Electric Power Research Institute, since its inception in 1972, has pioneered development of energy storage. Current programs are focusing on deployment of SMES, CAES, and batteries; and further assessments of the flywheels and super capacitors. The U.S. Department of Energy, through its Energy Storage Systems (ESS) Program, has focused almost exclusively on battery systems for the last decade for a variety of reasons, including technology versatility, applicability to customer needs, modular construction, and limited funds. Recently, the program has been expanded to include SMES, flywheels and advanced electrochemical capacitors. The ESS Program today performs collaborative research with industry on system integration and field testing, component development, and on systems analysis. Pumped hydro development was performed by the U.S. Army Corps of Engineers, flywheel development was done by the Department of Transportation, and SMES development was sponsored by the Department of Defense. Advanced electrochemical capacitors were investigated by the Department of Energy Defense Programs

Table 1. Energy storage technology profiles

Technology	Installed (U.S. total)	Facility Size Range	Potential/Actual Applications	Commercially Available	Selected Manufacturers	Estimated System Costs (\$1997)
Pumped Hydro	22 GW at 150 facilities in 19 states	Up to 2.1 GW	Electricity <ul style="list-style-type: none"> <li>• Load Leveling</li> <li>• Spinning Reserve</li> </ul>	Yes	Allis-Chalmers, Combustion Engineering, General Electric, North American Hydro, Westinghouse	500-1,600 \$/kW
CAES	110 MW in Alabama	25 MW to 350 MW	Electricity <ul style="list-style-type: none"> <li>• Peak Shaving</li> <li>• T&amp;D Applications</li> <li>• Spinning Reserve</li> </ul>	Yes	Dresser Rand, Westinghouse, ABB	350-500 \$/kW (commercial plant estimates)
Batteries	More than 70 MW installed by utilities in 10 states	From 100 W to 20 MW	Electricity <ul style="list-style-type: none"> <li>• Spinning Reserve</li> <li>• Integration with Renewables</li> <li>• T&amp;D Applications</li> <li>• Power Quality (PQ)</li> <li>• Peak Shaving</li> </ul> Transportation	Yes (Flooded Lead-Acid, VRLA)  No (Zinc/Bromine, Lithium)	AC Battery Corp, C&D, Delco-Remy, Delphi , GE Drive Systems, GNB, Precise Power Corp., SAFT America, Yuasa-Exide, ZBB	750-1,000 \$/kW (20-40 MW, 2 hrs) 500-600 \$/kW (20-40 MW, 0.5 hr) 400-600 \$/kW (2 MW, 10-20 sec)
Flywheels	1-2 demo facilities, no commercial facilities	kW-scale	Electricity <ul style="list-style-type: none"> <li>• Power Quality</li> </ul> Transportation Defense	Yes (steel, low rpm)  No (advanced composite)	American Flywheel Systems, Boeing, Int' l Computer Products, SatCon, US Flywheel Systems	Advanced: 6,000 \$/kW (~1 kW) 3,000 \$/kW (~20 kW) Steel: 500 \$/kW (1 MW, 15 sec)
SMES	5 facilities with approx. 30 MW in 5 states	From 1-10 MW (micro-SMES) to 10-100 MW	Electricity <ul style="list-style-type: none"> <li>• T&amp;D Applications</li> <li>• Power Quality</li> </ul>	Yes (micro-SMES)  No (larger units)	Superconductivity, Inc.	1,000 \$/kW (1-2 MW, 1 sec)
Advanced Electrochemical Capacitors	Millions of units for standby power; 1 defense unit	7-10 W commercial  10-20 kW prototype	Electricity <ul style="list-style-type: none"> <li>• Power Quality</li> </ul> Consumer Electronics Transportation Defense	Yes (low-voltage, standby power)  No (power quality)	Evans, Maxwell, NEC, Panasonic, Pinnacle, Polystor, Sony	unknown

Sources: References 1, 20, 22-25

## OVERVIEW OF ENERGY STORAGE TECHNOLOGIES

and Office of Transportation Technologies, although it appears that only defense applications are currently being pursued.

This report is focused on renewable energy generation technologies. The most appropriate storage systems for such applications presently appear to be batteries. Batteries have been installed in stand-alone PV and wind systems for more than two decades throughout the U.S. Worldwide sales of batteries attached to PV installations in 1995 were estimated at 3,000 MWh, with total installed of over 10,500 MWh. U.S. sales of PV batteries in 1995 were estimated at 340.5 MWh [26]. These annual sales statistics include both new installations and replacements. They are significant when considered against the amount of PV generating capacity in operation. By 1996, the U.S. PV industry had installed a total of 210 MW of PV generating capacity worldwide [16].

Batteries support renewable generation in at least three size ranges: (a) 1-4 kW residential, (b) 30-100 kW commercial, industrial, or village, and (c) > 1 MW generation or grid-support. Much of the activity funded by the PV industry has focused on residential-scale applications with oversized (many hours of) battery back-up, while much of the activity funded by the battery manufacturers has focused on the industrial-scale applications with low battery back-up. For example, EPRI and Sandia National Laboratories are completing an analysis of a 2.4 kW PV array and 7-hour battery operating in a grid-connected home in the Salt River Project service area [8].

Opportunities for PV are appearing in geographic zones previously excluded from consideration. The National Renewable Energy Laboratory (NREL), assisted by the State University of New York (SUNY) at Albany, has derived a new measure of effective PV capacity. The effective load-carrying capacity is the ability of any generator to effectively contribute to a utility's capacity to meet its load. While the intensity of solar insolation is critical to PV, it is less important than PV's relationship to load requirements [9]. SUNY researchers have developed a complementary measure of the minimum amount of back-up or stored energy needed to ensure that all utility loads above a threshold are met by the PV/storage system. The minimum buffer energy storage measure found that a small amount of storage could yield an increased capacity credit for PV.

The following technology characterization proceeds from the SUNY premise, examining an integrated 30 kW PV/30 kWh battery system connected to the electric grid.

### References

1. Hassenzahl, W.V., Energy Storage in a Restructured Electric Utility Industry—Report on EPRI Think Tanks I and II: September 1997. Report EPRI TR-108894.
2. Bos, P.B., and Borja, D.B., Strategic Assessment of Storage Plants, Economic Studies—Benefits Under a Regulated Versus Deregulated Utility, Polydyne, Inc.: January 1990. Report EPRI GS-6657.
3. Fancher, R.B., et al, Dynamic Operating Benefits of Energy Storage, Decision Focus, Inc.: October 1986. Report EPRI AP-4875.
4. Anderson, M.D., et al, "Assessment of Utility-Side Cost Savings for Battery Energy Storage," IEEE Transactions on Power Systems. Vol. 12, No. 3, pp. 1112-1120, August 1997.
5. Butler, P.C., Battery Energy Storage for Utility Applications: Phase I - Opportunities Analysis, Sandia National Laboratories: November 1995. Report SAND95-2605.

## OVERVIEW OF ENERGY STORAGE TECHNOLOGIES

6. Zaininger, H.W., Enhancing Wind and Photovoltaic Plant Value to Sacramento Municipal Utility District with Storage, Interim Report to Sandia National Laboratories: April 1995.
7. Zaininger, H.W., and P.R. Barnes, Applying Wind Turbines and Battery Storage to Defer Orcas Power and Light Company Distribution Circuit Upgrades, Oak Ridge National Laboratories, Oak Ridge, TN: March 1997. Report ORNL-Sub/96-SV115/1.
8. Salt River Project Residential Photovoltaic-Battery Energy Storage System Project, Electric Power Research Institute: January 1997. EPRI Report TC3779-003.
9. Perez, R., "Grid-Connected Photovoltaic Power," presented at Energy Storage Association meeting (April 1997).
10. Zaininger, H.W., et al, Potential Economic Benefits of Battery Storage to Electrical Transmission and Distribution Systems, Power Technologies, Inc.: January, 1990. Report EPRI GS-6687
11. DeSteele, J.G., et al, Utility Benefits of SMES in the Pacific Northwest, Battelle Northwest Laboratory: September 1996. Report EPRI TR-104802.
12. Torre, W.V. et al, Evaluation of Superconducting Magnetic Energy Storage for San Diego Gas & Electric, San Diego Gas & Electric Company: August 1997. Report EPRI TR-106286.
13. Akhil, A.A., L. Lachenmeyer, S.J. Jabbour, and H.K. Clark, Specific Systems Studies of Storage for Electric Utilities, Sandia National Laboratories: August 1993. Report SAND93-1754.
14. Norris, B.L., Economic Analysis of Distributed Battery Energy Storage, Pacific Gas & Electric: January 1994. Report 007.5-94.1.
15. Power Quality in Commercial Buildings, Electric Power Research Institute: 1995. Report EPRI BR-105018.
16. U.S. Department of Energy, Photovoltaics: the Power of Choice, DOE/GO10096-017, January 1996.
17. U.S. Department of Energy, Photovoltaic Fundamentals, DOE/CH10093-117-Rev. 1, February 1995.
18. "PV Balance of System Brief #3," Sandia National Laboratories, October, 1993, World Wide Web, [http://www.sandia.gov/Renewable\\_Energy/PV\\_Now/BOS/brief3.html](http://www.sandia.gov/Renewable_Energy/PV_Now/BOS/brief3.html).
19. Chapman, R.N., "Hybrid Power Technology for Remote Military Facilities," Ninth International Power Quality Solutions/International Power Quality Solutions/Alternative Energy Conference: Power System World '96 Conference and Exhibit, September 1996, pp. 415-427.
20. Parker, S.P., ed., Encyclopedia of Energy, McGraw-Hill, 1981.
21. Electric Power Research Institute, Compressed Air Energy Storage: 1994. EPRI Brochure BR-102936.
22. Zink, J.C., "Who Says You Can't Store Electricity?" Power Engineering, March 1997, pp. 21-25.
23. Akhil, A.A., S.K. Swaminathan, and R.K. Sen, Cost Analysis of Energy Storage for Electric Utility Applications, Sandia National Laboratories: February 1997. Report SAND97-0443.

## **OVERVIEW OF ENERGY STORAGE TECHNOLOGIES**

24. R&D Subcommittee Report on Capacitors, Power Sources Manufacturers Association: 1995.
25. E. C. Swensen, "CAES Status and the AEC 110 MW Plant," Energy Storage Association Spring Meeting 1997, April 30-May 1, 1997.
26. Hammond, R.L., et al., Photovoltaic Battery and Charge Controller Market and Applications Study, Sandia National Laboratories: December 1996. Report SAND96-2900.

# BATTERY STORAGE FOR SUPPLEMENTING RENEWABLE ENERGY SYSTEMS

## 1.0 System Description

Battery energy storage can be integrated with renewable energy generation systems in either grid-connected or stand-alone applications. For stand-alone systems, batteries are essential to store electricity for use when the sun is not shining or when the wind is not blowing. For grid-connected systems, batteries add value to intermittent renewable resources by facilitating a better match between the demand and supply.

The system characterized in this appendix consists of a 30 kWh battery energy storage system operating with a 30 kW PV array to shave peak load on the utility side of the meter. This system is sized for commercial or small industrial applications (low-rise buildings where PV arrays are mounted on the roof and the battery system is installed indoors) as opposed to residential (1-4 kW) or utility (multi-MW) applications. Although batteries can be charged either by the PV array when PV output exceeds on-site requirements, or by the grid during off-peak hours for use during peak periods when rates are higher, only the latter case is considered in this appendix based on the data available. This data is from the first-of-a-kind-product.

As indicated in Figure 1, the system components include a “max power tracker”, the battery subsystem, a power conditioning subsystem (PCS), switchgear and structural/mechanical items. The PV array consists of fixed PV modules that use large-area, solid-state semiconductor devices to convert sunlight into DC power. The PV subsystem is characterized elsewhere in this document.

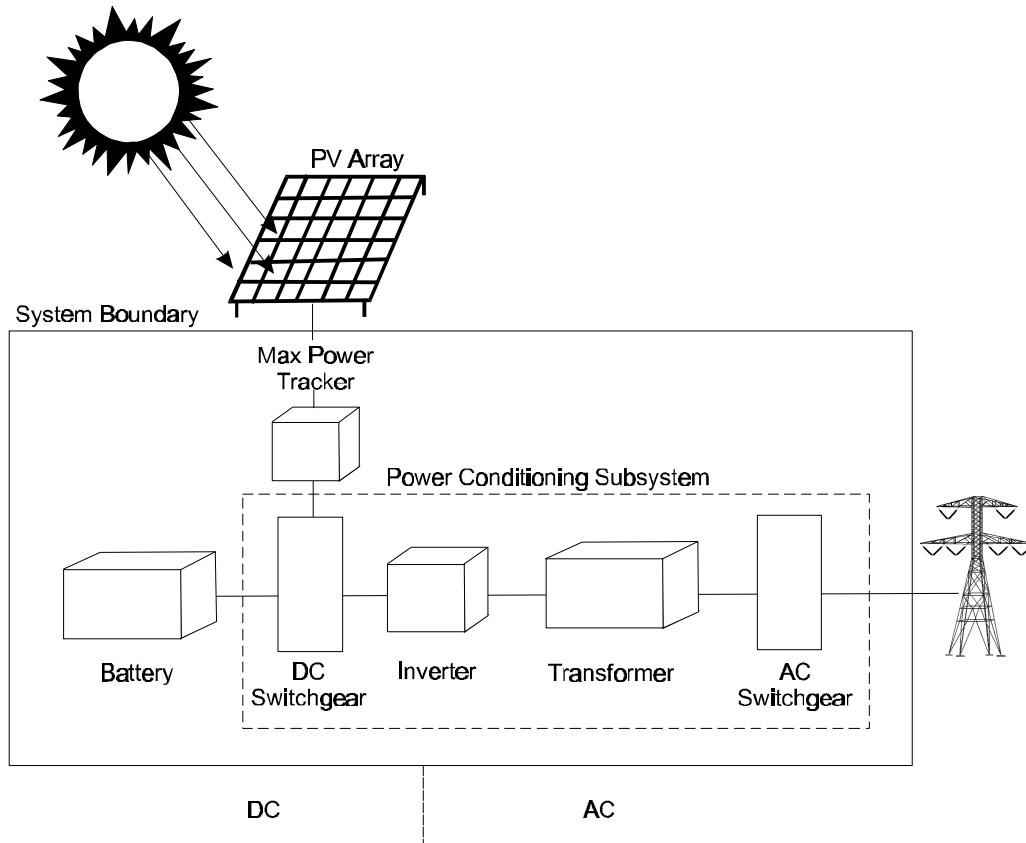

Figure 1. Battery storage system schematic.

## BATTERY STORAGE FOR SUPPLEMENTING RENEWABLE ENERGY SYSTEMS

Like PV cells, batteries are direct-current (DC) devices and are compatible with DC loads. Batteries not only store electrical energy -- in combination with a PCS, they can also enhance the quality of the power in the system. The battery can be discharged as required and therefore supply a variable electrical load. The PV array can then be designed to operate closer to its optimum power output [1].

Batteries are not specifically designed for PV systems. Most of the batteries used in current small PV systems were actually designed for use in deep-cycle electric vehicle or recreational vehicle applications where the recharge is carefully controlled and complete for every cycle. Insufficient battery recharge due to the diurnal limitations of PV output and poor charge control results in long periods of low state-of-charge which can be detrimental to some batteries, depending on design [2]. Lead-acid batteries are mostly used in integrated PV systems.

The PCS processes the electricity from the PV array and battery and makes it suitable for alternating-current (AC) loads. This includes (a) adjusting current and voltage to maximize power output, (b) converting DC power to AC power, (c) matching the converted AC electricity to a utility's AC electrical network, and (d) halting current flow from the system into the grid during utility outages to safeguard utility personnel. The conversion from DC to AC power in the PCS is achieved by an inverter, which is a set of electronic switches that change DC voltage from the solar array and/or battery to AC voltage in order to serve an AC load [1].

The PCS also maintains the DC voltage of the integrated PV system. It protects the batteries from excessive overcharge and discharge, either of which can cause permanent damage. The PCS usually includes a solid-state device, such as a blocking diode, that prevents current from flowing from the battery to the PV array and damaging it.

The max power tracker (also known as an auto power tracker) interfaces between the PV array and the storage system. Like the PCS, it also performs some power conditioning functions. It converts the DC energy from the PV array into a higher DC voltage to match the existing load or storage system. The max power tracker is needed in addition to the PCS to handle the voltage variability of the PV array and maximize its power output. The max power tracker monitors DC amperage and voltage from the PV array and employs an iterative method to match DC voltage of the PV array and the battery.

The key differences between the max power tracker and the PCS are:

<b>Max Power Tracker</b>	<b>Power Conditioning System</b>
Single channel	Three channels
DC components exclusively	DC and AC components
Accommodate high-voltage and current	Accommodate lower voltage which is less costly
Dedicated to PV	Not technology-specific

**Battery subsystem:** Most PV storage subsystems today consist of flooded lead-acid batteries. Improved valve-regulated lead-acid (VRLA) batteries are now emerging in utility systems. Advanced batteries (such as lithium ion and zinc/bromine) are being developed and are at different levels of size and readiness for utility operation. Other electric storage subsystems are addressed briefly in the Overview of Energy Storage Technologies, including flywheels, superconducting magnetic energy storage (SMES) and supercapacitors.

Batteries store chemical energy during electrical charging from a DC source, such as a PV array, or AC power from the electric grid can be converted to DC to charge the battery subsystem. For this technology characterization, it is



## BATTERY STORAGE FOR SUPPLEMENTING RENEWABLE ENERGY SYSTEMS

assumed the battery is recharged from the grid during off-peak hours. The battery storage subsystem complements the PV array, whose output is delivered to a commercial building load.

Batteries are complex devices whose performance is a function of many variables, including rate and depth of charge and discharge, temperature, and previous operating history [3]. The basic building block of the battery module is the electrochemical cell. Cells are packaged together into modules which are connected in a matrix of parallel-series combinations to form a string. Lead-acid batteries consist of two-volt (at open circuit) cells which are connected in series and parallel arrays as needed to match the desired electrical characteristics of the application. Extremely high discharges (thousands of amperes) are possible, and batteries can be switched very rapidly between open circuit, charge, or discharge.

**Power Conditioning Subsystem:** The PCS rectifies AC line power to DC to charge the battery, and inverts the DC power back to AC during discharge. It controls the rate of discharge and the switching time of the system. The power switches in a PCS are typically either GTO (gate turn off) or the newer, more flexible IGBT (insulated gate bipolar transistor) semiconductors. IGBT semiconductors have fewer requirements for driver circuitry, making inverters more compact and modular. IGBTs are used to overcome problems of poor power factor and high current harmonics [4].

The PCS functionally acts as a combination rectifier and inverter and may include a transformer. When the battery is being charged, the converter behaves like a rectifier, changing the AC into DC. When the battery is being discharged (supplying power to the system), the converter operates as an inverter. In the rectifier mode, the converter controls the voltage across the battery or the charging current. The PCS converts AC voltage to DC by firing power semiconductors so that the voltage in each of the transformer windings sums to that needed to cause the desired charge current to flow into the battery [5].

Additional PCS components include switchgear, both AC and DC; transformers as needed for voltage matching and isolation; and a controller for operating the system and interfacing with the host supervisory system. The control system has three main functions: (a) the storage subsystem control monitors charge level, charge/discharge requirements, and related operations, (b) the PCS control monitors the utility power supply and switches the system on- and off-line, and (c) the facility control monitors temperature, ventilation, and lighting in the structure housing the battery.

**Balance of plant:** Structural and mechanical equipment such as the protective enclosure, heating/ventilation/air conditioning (HVAC), and maintenance/auxiliary devices are non-trivial parts of the balance of plant. Other balance-of-plant features and costs include the foundation, structure (if needed), siting and permits, electrical protection and safety equipment, metering equipment, data monitoring equipment, communications and control equipment, and project management and training.

### 2.0 System Application, Benefits, and Impacts

**Application:** This document describes the use of a battery storage system in conjunction with a PV system to avoid or reduce the purchase of more costly on-peak power. However, energy storage systems can also play a flexible, multi-function role in an electric supply network to manage resources effectively. Battery energy storage systems are used for a variety of applications, such as: power quality assurance, transmission and distribution (T&D) facility deferral, voltage regulation, spinning reserve, load leveling, peak shaving, and integration with renewable energy generation plants [6]. Battery systems appear to offer the most benefits for utilities when providing power management support (i.e., voltage regulation, spinning reserve, customer peak shaving, integration with renewables, and T&D facility deferral) and when responding to instant voltage spikes or sags and outages.

## BATTERY STORAGE FOR SUPPLEMENTING RENEWABLE ENERGY SYSTEMS

**Benefits:** Specific studies at electric utilities considering battery energy storage systems revealed a number of generation, T&D, and customer-based benefits that are generally site-specific [5,6]. A number of factors determine the benefits of installing energy storage systems, such as storage size, location, system load profiles, and load profiles at individual substations and T&D lines.

A few battery energy storage systems are currently being demonstrated, some with U.S. DOE Energy Storage Systems (ESS) Program funding. Crescent Electric Membership Cooperative (CEMC) has been using a 500 kW lead-acid battery energy storage system for peak shaving purposes since 1987. CEMC has been able to significantly reduce the demand charges paid to its generation and transmission cooperative, North Carolina Electric Membership Cooperative [7].

Niagara Mohawk funded an investigation into peak load reduction with PV and buffer battery storage. The utility and the Empire State Electric Energy Research Corporation installed a 13 kW (AC) PV system on an energy-efficient office building in Albany, NY in 1990. The PV system operated as designed, but because afternoon clouds were reducing the PV system's effect on peak demand somewhat, Niagara Mohawk added a 21 kW/1-hour battery storage system in July 1993 [8]. The PV/battery prototype had the two systems operate in parallel, with off-peak grid power used to recharge the battery. It acted as a "quasi-dispatchable" unit, protecting against local load excesses and, thus, guaranteeing T&D benefits [9].

The manufacturer has since improved on this PV/battery system, by creating a compact system that can be installed on rooftops. Delmarva Power & Light is testing these units to determine whether, after PV generation cuts back at 4 P.M., the battery can provide three more hours of output to help shave peak loads in the summer. The prototypes were installed July 1996-April 1997 [10]. The unit can be operated locally or remotely; the batteries are charged from the grid overnight. Delmarva has successfully obtained peak shaving benefits from their operation. This quantity of storage is being evaluated to determine if the benefits of multiple hours of storage capacity justify the additional costs.

EPRI, Sandia National Laboratories, and the Salt River Project electric utility installed a 2.4 kW PV array and 25.2 kWh battery in an experimental residence owned by the utility. The system was designed to discharge the PV generated electricity stored in the batteries to match specific three-hour peak loads. The PV/battery system has operated continually and reliably since its installation in August 1995. No repairs or homeowner involvement has been needed. The only maintenance performed was periodic watering of the battery cells and manually changing the dispatch schedule each season [11].

There are many examples of battery energy storage integrated with PV facilities at national parks and military installations. For example, Dangling Rope Marina on Lake Powell in Utah is the largest PV system ever installed at a national park. The Dangling Rope PV system replaced an existing diesel generator and consists of a 115 kW PV array, a 250 kW power conditioning unit and a 2.4 MWh battery bank. The Yuma Proving Ground in Arizona has a grid-tied 441 kW PV system with 5.6 MWh of lead-acid batteries. During the summer peak season, the system can deliver 825 kW to the grid to help reduce peak demand. The system can also operate stand-alone in the event of an extended outage.

A number of studies have examined the contribution of storage coupled with renewable generation [9-15]. A recent study examined the benefits and costs of installing an integrated MW-scale windfarm with battery storage to defer the upgrade of a 25 kV circuit to 69 kV for Orcas Power and Light Company. Although sufficient wind potential was identified, the high winds did not generally occur coincidentally with peak loads on the distribution line. A transportable 500 kW/2-hour battery was considered for use during low wind periods to defer the upgrade in the distribution line until the year 2000 [15]. The study concluded that extremely high winds and high utility costs appear to economically justify the addition of MW-scale windfarms and battery storage.

## BATTERY STORAGE FOR SUPPLEMENTING RENEWABLE ENERGY SYSTEMS

**Impacts:** There are no emissions, solid wastes, or effluent produced during the operation of PV/battery energy storage systems. Flooded lead-acid batteries are closed, and VRLA and advanced batteries are essentially sealed. Electrolyte leakage from batteries is a rare occurrence because each lead-acid cell is surrounded by a double container. In the rare event of a leak, the fluid is captured by a containment system, neutralized and cleaned up as a chemical spill. The volume of leakage is typically small as each cell contains little liquid and there is very low likelihood that a large number of cells would break open simultaneously.

When the battery subsystems are replaced, essentially all battery materials (e.g., lead, acid, plastic casing) are captured and recycled. According to the Battery Council International, 95% of all lead available in scrapped batteries was recycled on average during 1990-1995. Batteries used in stationary applications represent less than 4% of the total tonnage of lead available for recycling during that period [16].

### 3.0 Technology Assumptions and Issues

Currently, there are a variety of PV array materials and battery energy storage technologies in use and under development. This document assumes off-the-shelf silicon-based PV panels are used, although the specific choice is not an issue. PV technology descriptions are provided elsewhere.

#### Battery Technologies

This appendix assumes that current R&D activities will lead to significant improvements in the cost and performance of battery storage systems. As these improvements take place, battery storage systems will compete with conventional sources of peak electric power generation, such as gas turbines, diesel generators, or uninterruptible power supply units. Flooded lead-acid and VRLA batteries are commercially available today, although not in designs wholly suited to utility applications. Zinc/bromine and lithium batteries are two advanced batteries under development. Each of these technologies has particular strengths and weaknesses.

**Lead-Acid Batteries:** Basically, flooded lead-acid battery technology for renewable energy storage systems is the large-scale application of a technology similar to that found in automobile batteries. Flooded lead-acid batteries are manufactured in large numbers for many uses and their operating characteristics and technology are well understood by manufacturers. However, they have several key limitations: (a) they require relatively frequent maintenance to replace water lost in operation, (b) they are relatively expensive compared to conventional options with limited reduction in cost expected, and (c) because of their use of lead, they are heavy, reducing their portability and increasing construction costs. The strengths of flooded lead-acid batteries center around their relatively long life span, durability, and the commercial availability of the technology. This allows flooded lead-acid battery customers to better justify their acquisitions and to amortize the cost of their systems over a longer period. Flooded lead-acid batteries are the most common batteries found in PV applications.

**VRLAs:** VRLAs use the same basic electrochemical technology as flooded lead-acid batteries, but these batteries are closed with a pressure regulating valve, so that they are essentially sealed. In addition, the acid electrolyte is immobilized. This eliminates the need to add water to the cells to keep the electrolyte functioning properly, or to mix the electrolyte to prevent stratification. The oxygen recombination and the valves of VRLAs prevent the venting of hydrogen and oxygen gases and the ingress of air into the cells. The battery subsystem may need to be replaced more frequently than with the flooded lead-acid battery, increasing the levelized cost of the system. The major advantages of VRLAs over flooded lead-acid cells are: a) the dramatic reduction in the maintenance that is necessary to keep the battery in operation, and b) the battery cells can be packaged more tightly because of the sealed construction and immobilized electrolyte, reducing the footprint and weight of the battery [17]. The disadvantages of VRLAs are that

## BATTERY STORAGE FOR SUPPLEMENTING RENEWABLE ENERGY SYSTEMS

they are less robust than flooded lead-acid batteries, and they are more costly and shorter-lived. VRLAs are perceived as being maintenance-free and safe and have become popular for standby power supplies in telecommunication applications, and for uninterruptible power supplies in situations where special rooms cannot be set aside for these batteries [7].

**Advanced Batteries:** Among the advanced batteries which may support renewable energy applications is the zinc/bromine system. It uses a flowing aqueous zinc bromide electrolyte, with metallic zinc being deposited on the negative electrode, while the bromine produced at the positive is stored in external tanks. The advantages of zinc/bromine battery technology are low cost, modularity, transportability, low weight, and flexible operation. Because of the chemical nature of the reactants and room-temperature operating conditions, the casing and components can be constructed from low-cost and light-weight molded plastic and carbon materials. The major disadvantages of zinc/bromine batteries center around the maintenance requirements, including upkeep of pumps needed to circulate the electrolyte, and the somewhat lower electrical efficiency. Also, the zinc deposited during the charging process must be completely removed periodically [17].

Other advanced batteries include the lithium-ion and lithium-polymer batteries which operate at or near ambient temperatures and may become appropriate for renewable energy applications. Rechargeable lithium batteries have already been introduced into the market for consumer electronics and other portable equipment in small button and prismatic cylindrical sizes [3]. The advantages of lithium batteries include their high specific energy (four times that of lead-acid batteries) and charge retention. However, scaling up to the sizes, power levels and cycle life required for large applications remains an exacting challenge.

Technology development currently underway (with assistance from the DOE-SNL-ESS program among others) is expected to significantly improve the performance and reduce the operation and maintenance (O&M) costs of energy storage systems. Engineering development is proceeding on VRLA battery systems, which are nearly commercial, and advanced battery systems, which may be near-commercial within 10 years. Government and private industry are currently developing a variety of advanced batteries for electricity, transportation, and defense applications: lithium ion, lithium polymer, nickel metal hydride, sodium metal chloride, sodium sulfur, and zinc bromine. The large cost of development of these new technologies is being shared by many organizations world-wide.

### Battery Operation

The life of a battery and its energy delivery capability are highly dependent on the manner in which it is operated. Many deep discharges (above 70-80%) reduce the life of lead-acid batteries. High rates of discharge reduce the energy delivery potential of lead-acid batteries. Batteries also have shelf-life limitations.

Poor charging practices are responsible for short battery life more than any other cause. A number of methods exist for charging batteries used in stationary utility applications. Optimum life and energy output from batteries, but not efficiency, are best achieved when depth of discharge (low, e.g., 40%) and time for recharge are predetermined and repetitive, a condition not always achievable in PV applications. Modified constant-potential charging is common for deep-cycling batteries and preferred for PV batteries designed for optimum life [3].

PV system manufacturers have incorporated battery storage into their off-grid installations for many years. Customers are beginning to request storage for grid-connected PV systems as well. The two systems have not been totally integrated; redundant PCS and balance of plant exist since both the PV modules and battery systems generally come with their own total package. The 1997 baseline system is derived from an existing 31 kW PV/21 kWh (40 minutes) flooded lead-acid battery system that is currently being demonstrated at five different utility sites. The systems are located in Newark and Wilmington, DE; Northeast, MD; Green Bay, WI; and Aberdeen, NC [10]. Although none of

## **BATTERY STORAGE FOR SUPPLEMENTING RENEWABLE ENERGY SYSTEMS**

the sites have excellent solar insolation, there is good coincidence between peak solar generation and peak demand of the host facility.

For this technology characterization, we assume a 30 kW system with one hour of storage available in the initial year and all outyears. The system is based on one module of a larger, commercially available (250 kW) power management battery system comprised of eight equally-sized modules. The 1997 system cost, benefits, and performance presented in Section 4.0 are based upon batteries and power electronics that are near-commercial today.

### **4.0 Performance and Cost**

Table 1 summarizes the performance and cost indicators for the storage portion of the system being characterized in this report.

#### **4.1 Evolution Overview**

The 1997 30 kW baseline system is based on a commercially-available 31 kW PV/flooded lead-acid battery system. The battery subsystem is assumed to improve and transition in technology type, changing from flooded lead-acid in 1997 and 2000 to VRLA beyond 2005. Advanced batteries are anticipated in 2020. These technology changes slow the cost reduction path for the battery subsystem. The PCS and max power tracker are expected to be integrated, so significant cost reductions are expected as modular design and factory-assembly become the norm and production volumes increase substantially. The balance of plant subsystems are expected to decline in cost as one-of-a-kind engineering and site-specific installations become less common.

#### **4.2 Performance and Cost Discussion**

The most productive hours of sunlight for PV systems are from 9 AM to 3 PM. Before and after these times, electricity is generated, but at much lower levels [8]. In addition, an afternoon thunderstorm will severely reduce local PV output before it will indirectly reduce the load by cooling ambient temperatures and suppressing solar heat gains. This has profound technical impacts that can negate some of the benefits associated with distributed, grid-connected PV. An hour of energy storage can alleviate this problem [9].

Table 1. Performance and cost indicators.

INDICATOR NAME	UNITS	Base Case		2000		2005		2010		2020		2030	
		1997	+/- %		+/- %		+/- %		+/- %		+/- %		+/- %
Plant Size	kW	30		30		30		30		30		30	
Battery Subsystem	Type	Lead-acid		Lead-acid		VRLA		VRLA		Adv. Battery		Adv. Battery	
Units Per Year	Each	5		50		200		200		200		200	
Performance													
Battery Replacement	Years	3		5		5		10		10		10	
AC-to-AC Efficiency	%	76		78		78		80		80		80	
Discharge	kWh/day	30		30		30		30		30		30	
Availability	%	90		90		90		90		90		90	
Annual Energy Delivery	MWh	2.7		2.7		2.7		2.7		2.7		2.7	
Energy Footprint	kWh/m <sup>2</sup>	13		13		15		15		26		26	
Selling Price													
Battery	\$/kW	350		200	10	300	15	275	20	300	30	275	30
Power Conditioning		650		600	10	550	15	500	20	400	30	300	30
Max Power Tracker		700		675	10	650	15	625	20	575	30	500	50
Balance of Plant		350		325	10	300	15	275	20	225	30	200	30
Total Capital Requirement		2,050		1,800		1,800		1,675		1,500		1,275	
Unit Operations and Maintenance Cost													
Fixed Costs	\$/kW												
Cooling		18		18		18		18		18		18	
General Maintenance		33		33		25		25		17		17	
Variable Costs	¢/kWh												
Charging (delivered)		2.1		2.0		2.0		2.0		2.0		2.0	
Battery Replacement		52		44		67		30		33		30	
Operations and Maintenance Cost													
Fixed Costs	\$/yr												
Cooling		548		548		548		548		548		548	
General Maintenance		1,000		1,000		750		750		500		500	
Variable Costs	\$/yr												
Charging		56		55		55		54		54		54	
Battery Replacement		3,500		1,200	10	1,800	15	825	20	900	30	825	30
Annual Operating Costs	\$/yr	4,600		2,800		3,200		2,200		2,000		1,900	

Notes:

1. The columns for "+/- %" refer to the uncertainty associated with a given estimate.
2. Battery system installation requires several hours.

## BATTERY STORAGE FOR SUPPLEMENTING RENEWABLE ENERGY SYSTEMS

### PV/Battery Sizing

There are different approaches to sizing batteries for PV applications. For stand-alone applications, some system developers have sized batteries to provide up to seven days of back-up. Examples include the following military installations:

- Navy facilities at China Lake (334 kW PV/3,500 kWh battery) and San Clemente Island (94 kW PV/2,500 kWh battery) in California
- Air Force facilities in Idaho (78 kW PV/700 kWh battery)
- Army training areas in Hawaii (5 kW PV/600 kWh battery)
- Marine tank target range in California (69 kW PV/2,000 kWh battery)

Sizing strategy for grid-connected PV installations depends on the uses of the system and the tariffs available from the local utility. For example, power quality applications require batteries sized to provide nearly instantaneous full-power discharges for only 15 minutes of back-up. A peak shaving application for a PV system may require the battery to boost the output of the array to meet peak loads for 1-2 hours a day. If the differential between peak and off-peak electric rates is not significant, then the battery can be sized for one hour of operation and the facility owner can purchase power from the grid when the PV array is not available. However, if the differential between peak and off-peak rates is significant, then an economic analysis should be undertaken to determine the optimum size of the battery system. For example, the 2.4 kW PV/25.2 kWh battery Salt River Project offered 17¢/kWh peak, 10¢/kWh shoulder, and 3¢/kWh off-peak experimental rates to the PV/battery demonstration it sponsored with EPRI and Sandia National Laboratories. The battery was sized to match the peak electric demand of the home (5 kW) or double the PV output (2.4 kW), in 3-hour load-shifting operations [11]. A number of PV developers optimize the PV installation, but not the battery system, opting for 7-10 hours of battery back-up power in the event of outages. In many cases, PV installations require only minimal battery back-up to add value to PV-generated electricity. If the transmission system is heavily loaded, batteries can store solar energy which would be lost during hours when transmission service is constrained, delivering the electricity later [14].

### Performance Indicators

The assumed economic life of the battery system is 30 years, requiring battery component replacements at appropriate intervals. The structure and power conditioning system are expected to last 30 years [18]. Battery replacement charges vary by the type of the battery and the number of years until replacement. One manufacturer claims that the type of flooded lead-acid batteries they use should be replaced every three years [25]. When VRLA batteries are used more widely for renewable applications in 2005, they initially are replaced at 5-year intervals, improving to 10-year intervals in 2010. Advanced batteries are assumed to require replacement once every 10 years when incorporated into the PV-battery system in 2020 [3,19]. This is an engineering estimate based on lifetime expectations for fundamental materials used in these battery systems and expectations for battery operation (charging and discharging).

The charging profile for the battery, which is pivotal in determining battery life, is controlled by the PCS for a grid-connected system. Continually undercharging a flooded lead-acid battery will cause it to sulfate, thereby greatly reducing battery life. Overcharging a VRLA battery at moderately high rates and above will cause it to dry out, thereby reducing its life. Thus, the design and operation of the PCS is a major determinant of the system life cycle costs [20].

Battery energy storage systems operate at an AC-to-AC efficiency of about 75%, and, therefore, consume some energy. However, storage systems can accumulate energy during periods when efficient base load or renewable generation are

## BATTERY STORAGE FOR SUPPLEMENTING RENEWABLE ENERGY SYSTEMS

available, and discharge during peak load times, thereby reducing the use of less efficient peaking generators. AC-to-AC efficiency is the ratio of AC energy removed from a storage system to the AC energy used to charge the system. This efficiency measure includes all losses in the storage system from the battery, PCS, switchgear, etc. The AC-to-AC efficiency values are based on the existing performance of installed storage systems in the field. In the future, systems are expected to become more efficient through the use of improved storage devices and better power electronics. The storage device will become more efficient due to the use of improved technologies. The power electronics will be enhanced through improved high-power switches that reduce losses [21]. As shown in Table 1, AC-to-AC efficiency increases from 76% in 1997 to 80% in 2010 and thereafter.

The annual energy delivery is calculated from the unit size and estimated operating time. Battery energy storage systems are assumed to be available 90% of the time. Annual energy delivered is the projected amount from the utilization of energy storage systems operated on average one hour per day for 100 days/year at 90% availability [22]. Heavy-duty batteries of the type that should be used in solar plants can cycle daily up to 250 days per year [14].

The system energy footprint, measured in kWh/m<sup>2</sup>, is an important characteristic of storage systems, many of which will be installed in facilities with fixed and/or small areas available. The example 1997 baseline system is very compact: 1.5 x 1.5 m deep (2.3 m<sup>2</sup>) and 1.3 m high. The unit weighs 1,724 kg and can be located in service bay areas, warehouses or storerooms [4]. The projected improvements in unit energy footprint are attributable to the expected increases in the energy density for VRLA and certain advanced battery technologies. The energy density of the VRLA, for example, is 15% greater than that of flooded lead-acid, hence the 15% increase in energy footprint.

The construction period is expected to be two months for PV array set-up; battery storage can be installed in a day or less [10]. The PV array is the only subsystem needed to be erected; all other components are contained in the modular, factory-assembled housing.

### System Capital Costs

The cost of an energy storage system is affected primarily by four drivers: (a) the initial cost of the storage subsystem, (b) the cost of the power converter, (c) the cost of the balance of system, and (d) the need to design, engineer, procure, and construct one-of-a-kind systems. The capacity of the plant as well as the discharging profile impact both capital and O&M costs. At present, flooded lead-acid batteries are the dominant choice for many utility applications. Flooded lead-acid batteries have been in widespread production and use for so long that further reductions in costs are unlikely [7]. Industry and government have been working to develop improved VRLA batteries and advanced batteries that offer potentially lower costs and longer cycle lives.

The 1997 cost estimates for the system are based on a turnkey price of \$65,800 for the baseline/PV battery system in limited production (based on the manufacturer's estimate). Sandia National Laboratories calculated the component costs based on experience in the field and products already under development [18,19,21]. Estimates done for this study for the 2005-2030 time frame are best-judgement engineering estimates based on expected increases in production; potential reductions in the costs of batteries, PCS, and balance of plant; and greatly reduced engineering costs for modular, factory-integrated systems.

An annual production volume of 160 system units (compared to production of 5 in 1997) has been identified by one battery manufacturer as necessary for costs to decline by 50%. Since the lead-acid battery is a mature technology, automating production and assembly is assumed to result in cost reductions of at least 10-15% over the next five years [19]. It is anticipated that this device will have a stable niche market of about 200 units a year in 2005 and beyond.



## BATTERY STORAGE FOR SUPPLEMENTING RENEWABLE ENERGY SYSTEMS

The battery portion of the system will be available for \$350/kW, with great potential for volume production savings. Sized for commercial use at 30 kW PV/30 kWh storage, the batteries account for less than 20% of the total cost of these systems. The introduction of VRLA technology in 2005 [19] will be about \$300/kW. As advanced batteries enter the market in 2020, battery costs are estimated at \$300/kW, with further reductions as production capability increases.

The PCS costs approximately \$650/kW (based on the estimate of \$65,800 for the entire system) and includes the converters, controls, AC/DC switchgear, filters, etc. According to a 1997 survey of manufacturers, PCS costs are expected to decrease by only 10% by 2000 since IGBT semiconductors are already in the design [19]. Subsequent reductions in PCS costs are substantial, bottoming out at \$300/kW in 2030. This reduction is expected to be due to further integration of the functions of the max power tracker and PCS, new advances in switch components, replacement of magnetics with less expensive materials, and high volume production.

Several organizations are also investigating ways to reduce power converter costs by encouraging more productive and efficient manufacturing processes and the utilization of the latest advances in power conversion technology. Manufacturers and system integrators are working to reduce or eliminate the need for one-of-a-kind engineering in all aspects of PV and storage system implementation. Failures of inverters are the number one cause of PV system problems. Cooperative R&D contracts support the development of quieter, more reliable inverters that can be mass-produced for the PV industry.

The max power tracker is an expensive customized component in this system (\$700/kW). One manufacturer sells 31 kW power trackers for \$22,000 [4]. Improvement in the max power tracker depends on advances in the PV power electronics industry and in increased production volumes. Max power tracker costs are projected to decrease to \$500/kW by 2030.

Balance of plant includes the facility to house the equipment, HVAC, the interface between the system and the utility, and the provision of services such as data gathering, project management, transportation, permitting, and financing. Balance of plant costs are low for this PV/storage system because compact design enables the entire system to be housed in a container. The balance of plant costs are reduced during the forecast period from \$350/kW to \$200/kW as lightweight, modular, factory-assembled systems become the norm [18,19,21].

### System O&M Costs

Operation & maintenance costs consist of fixed and variable costs. Fixed costs include cooling and general maintenance at the site. Variable costs include recharging the batteries and periodically replacing the batteries. These O&M costs are presented as annual expenses in the prior table. The cooling charge is based on a power management system which consists of eight modules, each one of which is the same size as the system being characterized here [18]. The unit must be installed in an air-conditioned room [4], and thus, the parasitic load for the cooling fans is quite small at 1.25 kW. At a peak or shoulder rate of 5¢/kWh, the annual cost of the cooling load for the 30 kW system is \$548. The general maintenance cost of \$1,000/year is based on the experience of CEMC with a larger flooded lead-acid battery.

The recharging cost is calculated as the kW rating \* discharge time \* ( (1 - AC-to-AC efficiency) + 1) \* off-peak ¢/kWh rate \* 100 days/year. The 30 kW unit requires a 37.2 kWh charge (given 76% efficiency [4]), at a 1.5¢/kWh off-peak rate, costs \$56 annually in 1997.

## BATTERY STORAGE FOR SUPPLEMENTING RENEWABLE ENERGY SYSTEMS

The cost of battery replacement is based on an expected battery life of three years. Thus, on average, the annual cost of battery replacement is one third the cost of the batteries. Expanded battery life increases to five years in 2000 and ten years in 2010 and later, so replacement costs improve accordingly.

### 5.0 Land, Water, and Critical Materials Requirements

There are no water requirements for PV-battery energy storage systems. Land requirements are insignificant for the battery system which occupies less than 2.3 m<sup>2</sup>.

The 1997 baseline system contains a lead-acid battery; 50% of the system weight (excluding the PV array) is lead. Battery system weight will decrease significantly when the advanced battery subsystem is introduced in 2020.

### 6.0 References

1. U.S. Department of Energy, Photovoltaic Fundamentals, DOE/CH10093-117-Rev.1, February 1995.
2. "PV Balance of System Brief #3," Sandia National Laboratories, October, 1993, World Wide Web, [http://www.sandia.gov/Renewable\\_Energy/PV\\_Now/BOS/brief3.html](http://www.sandia.gov/Renewable_Energy/PV_Now/BOS/brief3.html).
3. Linden, D., Handbook of Batteries and Fuel Cells, 2nd Edition, Mc-Graw-Hill, New York, NY, 1995.
4. "PV31 Photovoltaic Dispatchable Battery Energy Storage System," AC Battery Corporation, East Troy, WI: Undated. Report PV TDS1095.
5. Akhil, A.A., L. Lachenmeyer, S.J. Jabbour, and H.K. Clark, Specific Systems Studies of Storage for Electric Utilities, Sandia National Laboratories: August 1993. Report SAND93-1754.
6. Butler, P.C., Battery Energy Storage for Utility Applications: Phase I - Opportunities Analysis, Sandia National Laboratories: November 1995. Report SAND95-2605.
7. Battery Energy Storage Market Feasibility Study, Frost & Sullivan: July 1997. Report SAND97-1275.
8. Web Case Studies, Solar Energy Industries Association, World Wide Web, <http://www.seia.org/>.
9. Perez, R., et.al., "Providing Firm Peak Load Reduction with PVs: Operational Results of the NMPC PV+Buffer Storage Prototype," Proceedings of at the American Solar Energy Society Conference, San Jose, CA (1994).
10. Nigro, R., "Opportunities for Battery Storage: Results of the PV BONUS Program," presented at Energy Storage Association meeting (April 1997).
11. Salt River Project Residential Photovoltaic-Battery Energy Storage System Project, Electric Power Research Institute: January 1997. Report TC3779-003.
12. Perez, R., "Grid-Connected Photovoltaic Power," presented at the Energy Storage Association meeting (April 1997).

## BATTERY STORAGE FOR SUPPLEMENTING RENEWABLE ENERGY SYSTEMS

13. Osborn, D.E., and D.E. Collier, "Utility Grid-Connected Photovoltaic Distributed Power Systems," Proceedings of the American Solar Energy Conference, Asheville, NC (1996).
14. Zaininger, H.W., Enhancing Wind and Photovoltaic Plant Value to Sacramento Municipal Utility District with Battery Storage, Interim Report to Sandia National Laboratories: April 1995.
15. Zaininger, H.W., and P.R. Barnes, Applying Wind Turbines and Battery Storage to Defer Orcas Power and Light Company Distribution Circuit Upgrades, Oak Ridge National Laboratories, Oak Ridge, TN: March 1997. Report ORNL-Sub/96-SV115/1.
16. National Recycling Rate Study, Smith, Buckin & Associates, Inc., for Battery Council International: December 1996.
17. Butler, P.C., Utility Battery Storage Systems Program Report for FY95, Sandia National Laboratories: November 1995. Report SAND95-2605.
18. Final Report on the Development of a 250-kW Modular, Factory-Assembled Battery Energy Storage System, Omnion Power Engineering Company: July 1997. Report SAND97-1276.
19. Akhil, A.A., S.K. Swaminathan, and R.K. Sen, Cost Analysis of Energy Storage for Electric Utility Applications, Sandia National Laboratories: February 1997. Report SAND97-0443.
20. Hammond, R.L., et.al., Photovoltaic Battery and Charge Controller Market and Applications Study, Sandia National Laboratories: December 1996. Report SAND96-2900.
21. Power Processing Systems - Workshop Report, Energetics, for Sandia National Laboratories: November 1993.
22. Norris, B.L., Economic Analysis of Distributed Battery Energy Storage, Pacific Gas & Electric: January 1994. Report 007.5-94.1.