

Energy Savings Potential and Research, Development, & Demonstration Opportunities for Commercial Building Heating, Ventilation, and Air Conditioning Systems

September 2011

NOTICE

This report was prepared as an account of work sponsored by an agency of the United States Government. Neither the United States Government, nor any agency thereof, nor any of their employees, nor any of their contractors, subcontractors, or their employees, makes any warranty, express or implied, or assumes any legal liability or responsibility for the accuracy, completeness, or usefulness of any information, apparatus, product, or process disclosed, or represents that its use would not infringe privately owned rights. Reference herein to any specific commercial product, process, or service by trade name, trademark, manufacturer, or otherwise, does not necessarily constitute or imply its endorsement, recommendation, or favoring by the United States Government or any agency, contractor or subcontractor thereof. The views and opinions of authors expressed herein do not necessarily state or reflect those of the United States Government or any agency thereof.

Available electronically at <http://www.osti.gov/home/>

Energy Savings Potential and RD&D Opportunities for Commercial Building HVAC Systems

Prepared for:

U.S. Department of Energy

Office of Energy Efficiency and Renewable Energy

Building Technologies Office

<http://www.eere.energy.gov/buildings>

Prepared by:

Navigant Consulting, Inc.

77 South Bedford Street, Suite 400

Burlington, MA 01803

William Goetzler

Robert Zogg

Hirokazu Hiraiwa

Javier Burgos

Jim Young

September 30, 2011

Table of Contents

Table of Contents	i
List of Acronyms	iv
Executive Summary	vii
1 Introduction.....	1
1.1 Report Organization	1
1.2 Background	1
2 Technology Selection and Screening Processes	5
2.1 Develop initial list of technology options – Step 1	5
2.2 Identify 50 to 70 technology options for further study – Steps 2 and 3	6
2.3 Preliminary Analysis of the 57 technology options – Step 4	8
2.3.1 Overview of the Preliminary Analysis.....	8
2.3.2 Estimating Technical Energy-Savings Potential.....	9
2.4 Scoring criteria for the 57 technology options – Step 5	11
2.5 In-depth analysis of final priority technologies – Step 6	12
3 In-Depth Analyses of the Final Priority Technologies	14
3.1 Advanced Component Technologies	16
3.1.1 Smart Refrigerant Distributors.....	16
3.1.2 Thermoelectrically Enhanced Subcooling	25
3.2 Alternative Heating & Cooling Technologies.....	32
3.2.1 Liquid Desiccant Air Conditioner.....	32
3.2.2 Magnetic Cooling Cycle	40
3.2.3 Solar Enhanced Cooling System.....	46
3.2.4 Solar Ventilation Preheating	54
3.2.5 Thermoelectric Cooling System	62
3.2.6 Thermotunneling Cooling System	70
3.3 Thermal Distribution Systems.....	77
3.3.1 Aerosol Duct Sealing	77
3.3.3 Duct-Leakage Diagnostics	92
3.3.4 Ductwork in the Conditioned Space	98
3.3.5 Thermal Displacement Ventilation	106
3.4 Performance Optimization & Diagnostics	114
3.4.1 Retrocommissioning	116
3.4.2 Continuous Commissioning.....	123
3.4.3 Building Energy Information Systems.....	131
3.4.4 Fault Detection and Diagnostics for Packaged HVAC Equipment	137
4 Abridged Analyses of the Eight Early-Stage Technologies	145
4.1 Bernoulli Heat Pump.....	146
4.2 Desiccant Assisted Evaporative Air-Conditioner (DEVap A/C)	148
4.3 Metal Foam Heat Exchangers	150
4.4 Nanofluid Refrigerant Additives.....	152

4.5	Thermoelastic Cooling	154
4.6	Thermoelectrically Enhanced Radiators	156
4.7	Turbo-Compressor-Condenser-Expander	158
4.8	Zephyr Ceiling Tiles.....	160
5	Conclusions.....	162
5.1	Summary of the Technology Screening Process.....	162
5.2	Comparison with 2002 TIAX Study	163
5.3	Observations on the Final Priority Technology Options.....	168
5.3.1	Technology Categories	168
5.3.2	Non-Energy Benefits	168
5.3.3	Technical Maturity.....	169
5.3.4	Cost and Complexity.....	170
5.4	Summary of Recommended Technology Development Initiatives	172
5.4.1	Summary of Recommended DOE-Led Initiatives.....	173
5.4.2	Summary of Recommended Manufacturer-Led Initiatives	175
5.4.3	Summary of Recommended Industry Organization-Led Initiatives.....	176
5.4.4	Summary of Recommended Utility Initiatives	177
Appendix A	List of the Initial 135 Technology Options	179
Appendix B	Preliminary Analyses	182
B.1	Advanced Absorption Pairs.....	183
B.2	Airfoil Blade Centrifugal Fans and Blowers.....	186
B.3	Chilled Beam Radiant Cooling	188
B.4	Cold Weather Heat-Pump	191
B.5	Copper Rotor Motors	194
B.6	Damper FDD (Fault Detection & Diagnostics).....	196
B.7	Dedicated Outdoor Air System	199
B.8	Dual-Source Heat Pump.....	202
B.9	Duct Static Pressure Reset Control	204
B.10	Electrohydrodynamic Heat-Transfer Enhancement	207
B.11	Fans Optimized for Every Application.....	209
B.12	High-temperature Superconducting Motors	211
B.13	Hot-Dry Air-Conditioner.....	213
B.14	Membrane Humidity Control with Advanced Active Desiccant Materials	216
B.15	Microchannel Heat Exchangers.....	218
B.16	Mixed-mode Conditioning	220
B.17	Modular Chillers and Boilers	223
B.18	Multilevel FDD (Fault Detection and Diagnostics)	225
B.19	Nanofluids Enhanced Twisted Tape Heat Exchanger	228
B.20	Optimized Heat Exchangers	231
B.21	Passive Unsteady Airflow Mechanisms	233
B.22	Permanent Magnet Motors	235
B.23	Regular Maintenance.....	237
B.24	Seasonal Thermal Energy Storage.....	240
B.25	Smaller Centrifugal Compressors.....	243
B.26	Small-Grooved Copper Tubes	246

B.27	Switched Reluctance Motors	249
B.28	Triple Effect Absorption Chiller.....	251
B.29	Thermal Energy Storage System in Rooftop Units	253
B.30	Variable Blade Pitch.....	256
B.31	Variable Refrigerant Volume Systems (VRV/VRF).....	258
B.32	Water-Cooled Condensers for Unitary Equipment	261
Appendix C Technical Energy-Savings Potential of the 57 Technology Options (Except Early-Stage Technologies).....		264

List of Acronyms

A/C or AC	Air-Conditioning
ACEEE	American Council for Energy-Efficient Economy
ACHR	Air-Conditioning, Heating, & Refrigeration News
AEC	Architectural Energy Corporation
AHRI	Air-Conditioning, Heating, & Refrigeration Institute
AHRTI	Air-Conditioning, Heating, & Refrigeration Technology Institute
ARPA-E	Advanced Research Projects Agency-Energy
ARTI	Air-Conditioning and Refrigeration Technology Institute
ASHRAE	American Society of Heating, Refrigerating, and Air-Conditioning Engineers
BAIHP	Building America Industrialized Housing Partnership
BT	Building Technologies Program (U.S. DOE)
CBEA	Commercial Building Energy Alliance
CBECS	Commercial Buildings Energy Consumption Survey
CC	Continuous Commissioning
CEC	California Energy Commission
CFM	Cubic Feet per Minute
CO ₂	Carbon Dioxide
COP	Coefficient of Performance
DCV	Demand-Controlled Ventilation
DOAS	Dedicated Outdoor Air System
DOE	U.S. Department of Energy
DR	Demand Response
EER	Energy-Efficiency Ratio
EERE	Office of Energy Efficiency & Renewable Energy (U.S. DOE)
EIS	Energy Information System
EMS	Energy Management System
EPA	U.S. Environmental Protection Agency
ES	Executive Summary
FDD	Fault Detection & Diagnostics
FPL	Florida Power & Light
ft	Foot
GE	General Electric
GWP	Global Warming Potential
HFC	Hydrofluorocarbon
HT	Heat Transfer
HVAC	Heating, Ventilation and Air Conditioning
HVAC	Heating, Ventilation and Air-Conditioning
HX	Heat Exchanger
IAQ	Indoor Air Quality

IIR	International Institute for Refrigeration
ITC	Isothermal Turbocompressor
JARN	Japan Air Conditioning, Heating & Refrigeration News
LBNL	Lawrence Berkeley National Laboratory
LDAC	Liquid Desiccant Air Conditioner
LEED	Leadership in Energy and Environmental Design
LEED-EB	LEED Certification for Existing Buildings
NILM	Non-invasive Load Monitoring
NIST	National Institute of Standards and Technology
nm	nanometer (10^{-9} m)
NREL	National Renewable Energy Laboratory
NYSERDA	New York State Energy Research & Development Authority
O&M	Operations & Maintenance
OA	Outdoor Air
OEM	Original Equipment Manufacturer
ORNL	Oak Ridge National Laboratory
PG&E	Pacific Gas & Electric
PNNL	Pacific Northwest National Laboratory
ppm	parts per million
PV	Photovoltaic
Quad	Quadrillion (10^{15}) British Thermal Units
R&D	Research & Development
RCx	Retrocommissioning
RD&D	Research, Development & Demonstration
RTU	Rooftop Unit
SEER	Seasonal Energy-Efficiency Ratio
Sq.ft.	Square Foot
ss	Steady State
T	Tesla
TCCE	Turbo-Compressor-Condenser-Expander
TDV	Thermal Displacement Ventilation
TE	Thermoelectric
TIM	Thermal Interface Material
UMD	University of Maryland
VAV	Variable Air Volume
VOC	Volatile Organic Compound
W	Watt
WSU	Washington State University
ZCT	Zephyr Ceiling Tile
ZT	Dimensionless figure of merit for thermoelectric materials
A/C or AC	Air-Conditioning
ACEEE	American Council for Energy-Efficient Economy
ACHR	Air-Conditioning, Heating, & Refrigeration News

AEC	Architectural Energy Corporation
AHRI	Air-Conditioning, Heating, & Refrigeration Institute
AHRTI	Air-Conditioning, Heating, & Refrigeration Technology Institute
ARPA-E	Advanced Research Projects Agency-Energy
ARTI	Air-Conditioning and Refrigeration Technology Institute
ASHRAE	American Society of Heating, Refrigerating, and Air-Conditioning Engineers
BAIHP	Building America Industrialized Housing Partnership
BT	Building Technologies Program (U.S. DOE)
CBEA	Commercial Building Energy Alliance
CBECS	Commercial Buildings Energy Consumption Survey
CC	Continuous Commissioning
CEC	California Energy Commission
CFM	Cubic Feet per Minute
CO ₂	Carbon Dioxide
COP	Coefficient of Performance
DCV	Demand-Controlled Ventilation
DOAS	Dedicated Outdoor Air System
DOE	U.S. Department of Energy
DR	Demand Response
EER	Energy-Efficiency Ratio
EERE	Office of Energy Efficiency & Renewable Energy (U.S. DOE)
EIS	Energy Information System
EMS	Energy Management System
EPA	U.S. Environmental Protection Agency
ES	Executive Summary
FDD	Fault Detection & Diagnostics
FPL	Florida Power & Light

Executive Summary

The U.S. Department of Energy (DOE), Office of Energy Efficiency and Renewable Energy (EERE), Building Technologies Program (BT) commissioned this assessment of heating, ventilation, and air-conditioning (HVAC) technologies for U.S. commercial buildings. The main objectives of this study were to:

- Identify a wide range of technology options in varying stages of development that could reduce commercial HVAC energy consumption;
- Provide in-depth analysis of priority technology options, including: technical energy-savings potential¹; applicability to different building or HVAC equipment types; non-energy benefits; and perceived barriers to market adoption.
- Develop suggestions for potential research, development and demonstration (RD&D) initiatives that would support further development of the technology options that are most promising based on technical energy-savings potential, potential fit with DOE BT's RD&D portfolio, cost and complexity, and other factors.

Figure ES-1 presents the steps of the technology selection, screening and assessment process we followed for this study.

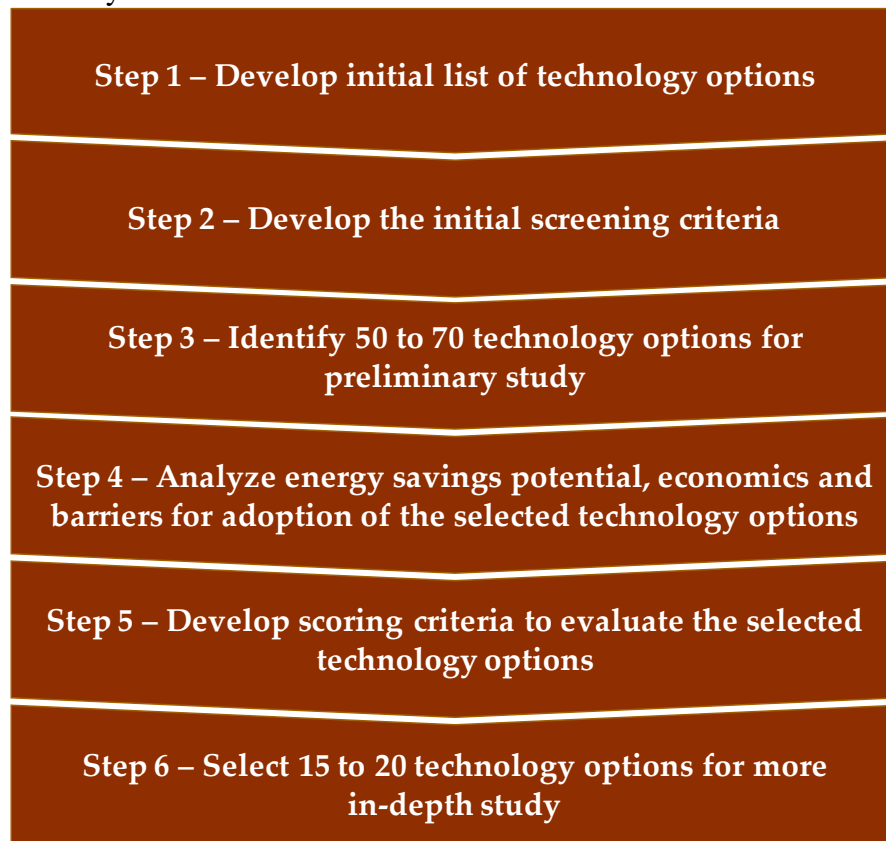

Figure ES-1: Selection and Screening Process

¹ Technical energy-savings potential is the theoretical national primary energy savings that could be achieved if all technically suitable installations are replaced with a particular energy-saving technology.

We first generated a comprehensive list of 182 technology options (listed in Appendix A) from a variety sources including: manufacturers’ websites, industry publications, government organizations, university research, and internal Navigant experts. Through this initial survey, we cataloged general information about each technology such as its potential energy-efficiency impact and potential applicability to various commercial HVAC systems. After examining the initial list, we removed 125 technology options , leaving 57 technology options that demonstrated the highest potential to reduce HVAC energy consumption in commercial buildings, but that have not yet been adopted widely by the market (see **Table ES-1**).

Table ES-1: 57 Technology Options Selected for Further Study

Components (24)	Equipment (13)
Advanced Absorption Pairs	Centrifugal Bernoulli Heat Pump
Aerosol Duct Sealing	Cold Weather Heat Pump
Airfoil-Blade Centrifugal Fan	DEVap A/C
Copper Rotor Motor	Dual-Source Heat Pump
Electrohydrodynamic Heat-Transfer Enhancement	Hot-Dry Air-Conditioner
Fans Optimized for Every Application	Liquid Desiccant Air-Conditioner
High-Temperature Superconducting Motors	Magnetic Cooling Cycle
Metal Foam Heat Exchangers	Membrane Humidity Control with Advanced Active Desiccant Materials
Microchannel Heat Exchangers	Solar Enhanced Cooling
Nanofluid Refrigerant Additives	Thermoelastic Cooling Cycle
Optimized Heat Exchangers	Thermoelectric Cooling Cycle
Passive Unsteady Airflow Mechanisms	Thermotunneling Cooling Cycle
Permanent Magnet Motors	Triple-Effect Absorption Chillers
Smaller Centrifugal Compressors	
Small-Grooved Copper Tubes	
Smart Refrigerant Distributors	
Switched Reluctance Motors	Controls (1)
Thermoelectrically Enhanced Radiators	Building Energy Information System
Thermoelectrically Enhanced Subcoolers	
Turbo-Compressor-Condenser-Expander	
Variable-Pitch Fans	
Water-Cooled Condensers for Unitary Equipment	Systems (11)
Zephyr Ceiling Tiles	Chilled Beam Radiant Cooling
	Dedicated Outdoor Air System

Operations/Maintenance (8)	Demand-Controlled Ventilation
Continuous Commissioning	Ductwork in the Conditioned Space
Damper FDD	Mixed-mode Conditioning
Duct Static Pressure Reset and Control	Modular Chillers and Boilers
Duct-Leakage Diagnostics	Seasonal Thermal Energy Storage
Multilevel FDD	Solar Ventilation Preheating
Packaged Rooftop Unit FDD	Thermal Displacement Ventilation
Regular Maintenance	Unitary Thermal Energy Storage System
Retrocommissioning	VRV/VRF

Next, we conducted a preliminary analysis of each of the 57 technologies to better understand their technical energy-savings potential for commercial HVAC systems in the U.S. We determined the technical energy-savings potential for each technology option by combining HVAC energy-use data from the *2011 Building Energy Data Book* [US DOE (2011)], the latest data from *2003 Commercial Building Energy Consumption Survey* [US DOE (2005)], and unit energy-savings estimates. For each technology option, this analysis expanded our understanding of: technical energy-savings potential and installed costs, retrofit potential, peak-demand reduction, other non-energy benefits, barriers to market adoption, and next-steps for technology development.

Based on the preliminary analysis, we conducted another round of technology screening based on five criteria: technical energy-savings potential; fit with DOE BT mission; cost/complexity; availability of non-energy benefits; and potential for peak-demand reduction. After scoring each technology option (referencing the preliminary analyses and Navigant experts), we chose 17 priority technology options for the final in-depth analysis. Each technology option shows strong potential to have one or more of the following impacts:

- Provides heating or cooling more efficiently using novel technologies, strategies and/or components, or offsets the energy consumption of conventional systems by optimizing the performance of critical components.
- Eliminates duct leakage and/or maximizes the performance of ventilation systems to significantly lower the energy consumption associated with thermal distribution.
- Uses diagnostics, monitoring and evaluation to optimize and maintain the efficiency of commercial HVAC systems over time.

Table ES-2 categorizes and presents the 17 priority technology options that we chose for the final in-depth analysis.

Table ES-2: Summary of the Final Priority Technology Options

Category	Applicable Technology Options
Advanced Component Technologies	<ul style="list-style-type: none"> - Smart Refrigerant Distributors - Thermoelectrically Enhanced Subcoolers
Alternative Heating & Cooling Technologies	<ul style="list-style-type: none"> - Liquid Desiccant A/C - Magnetic Cooling Cycle - Solar Enhanced Cooling - Solar Ventilation Preheating - Thermoelectric Cooling Cycle - Thermotunneling Cooling Cycle
Thermal Distribution Systems	<ul style="list-style-type: none"> - Aerosol Duct Sealing - Demand-Controlled Ventilation - Duct-Leakage Diagnostics - Ductwork in Conditioned Space - Thermal Displacement Ventilation
Performance Optimization & Diagnostics	<ul style="list-style-type: none"> - Building Energy Information System - Continuous Commissioning - Packaged RTU FDD - Retrocommissioning

Roth, et al. (2002), a similar study commissioned by DOE BT, considered 175 technology options and selected 15 technology options for in-depth analysis. The difference in the respective screening criteria led us to choose some technology options for in-depth analysis that the 2002 study screened out. In other cases, changes in the development status and level of market adoption led us to screen out some technology options due to their poor fit with DOE-BT’s mission.

Figure ES-2 compares the technical energy-savings potential for the 17 priority technology options. Appendix B contains the preliminary analyses for the technology options not chosen for the final in-depth analysis.

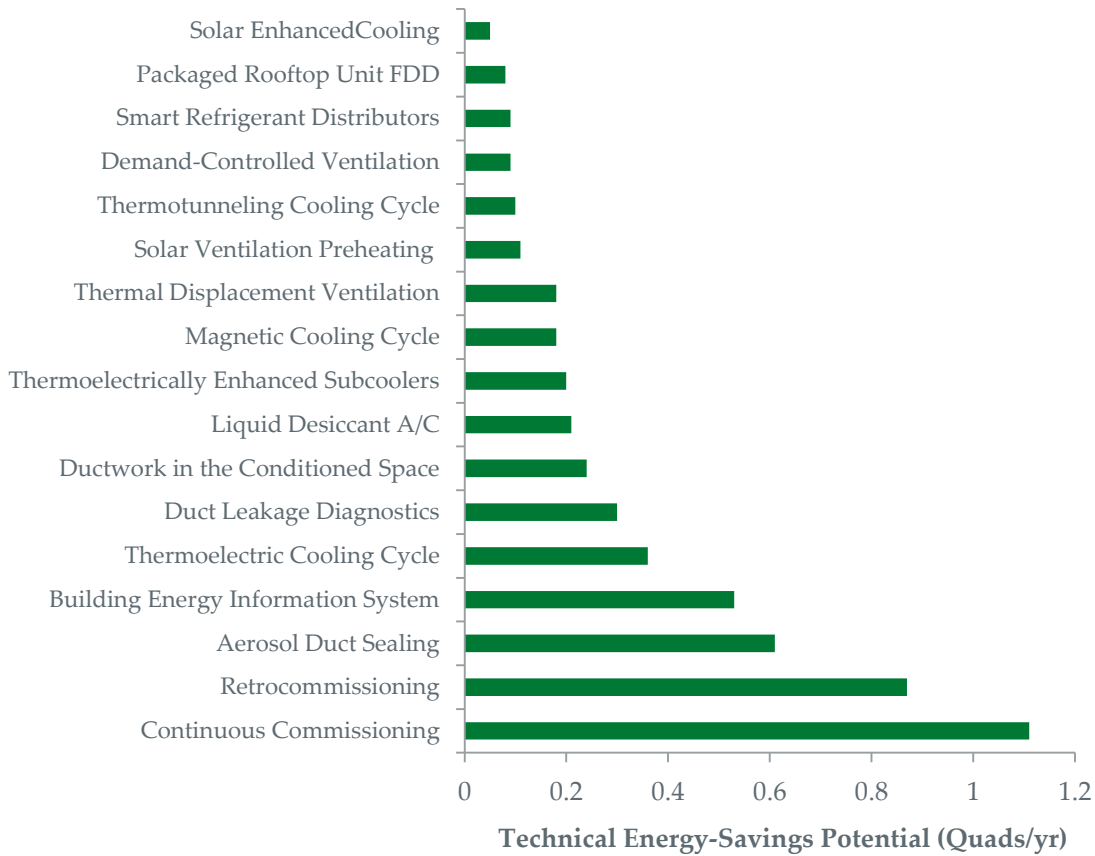

a. Potential savings are not additive for most technology options and applications

Figure ES-2: Technical Energy-Savings Potential for the Final Priority Technology Options^a

Because technical energy-savings potential depends both on the applicability of the technology option across HVAC equipment/systems and the projected annual unit energy savings, technology options that address both heating and cooling (e.g., Aerosol Duct Sealing) or benefit multiple HVAC system types (e.g., Retrocommissioning) tend to have the largest technical energy-savings potentials. Technology options that could be readily retrofit into existing buildings either as a supplementary system (e.g., Building Energy Information Systems) or that could be integrated in replacement equipment (e.g., Thermoelectric Cooling Cycles) tend to have higher technical energy-savings potential as well.

Based on our review of the 17 priority technologies, we recommend that DOE and industry stakeholders focus on the 13 initiatives summarized in Table ES-3.

Table ES-3: Summary of Recommended Initiatives for the Final Priority Technologies

Recommended Lead Organization	Recommended Initiatives	Applicable Technology Options
DOE (R&D-Stage Technology Options)	Support development of advanced high-ZT materials and low work-function materials	<ul style="list-style-type: none"> • Thermoelectric Cooling Cycle • Thermoelectrically Enhanced Subcoolers
	Support development of designs reducing the use of rare-earth metals	<ul style="list-style-type: none"> • Magnetic Cooling Cycle
	Support development of improved manufacturing strategies for small-scale, advanced-material technologies	<ul style="list-style-type: none"> • Thermoelectric Cooling Cycle • Thermoelectrically Enhanced Subcooler • Thermotunneling Cooling Cycle
DOE (Emerging and Commercially Available Technology Options)	Conduct long-term field studies on alternative ventilation strategies	<ul style="list-style-type: none"> • Demand-Controlled Ventilation • Thermal Displacement Ventilation
	Support development of strategies to facilitate assessment of airflow and thermal efficiency of ducts	<ul style="list-style-type: none"> • Aerosol Duct Sealing • Duct-Leakage Diagnostics • Ductwork in the Conditioned Space
	Support further refinement of the energy economics for performance optimization and diagnostics technologies	<ul style="list-style-type: none"> • Building Energy Information System (EIS) • Continuous Commissioning
	Develop greater understanding of real-world energy performance for HVAC equipment and systems over their lifetime	<ul style="list-style-type: none"> • Packaged Rooftop Unit Fault Detection and Diagnostics (FDD) • Retrocommissioning
Manufacturers	Develop techniques for cost-effective integration of component technologies into existing systems	<ul style="list-style-type: none"> • Smart Refrigerant Distributors • Thermoelectrically Enhanced Subcoolers
	Conduct demonstrations of, and publish field data for, advanced components using a variety of refrigerant types and equipment designs	

	Optimize the capabilities, and number, of sensors for performance optimization and diagnostics systems	<ul style="list-style-type: none"> • Building EIS • Continuous Commissioning • Packaged Rooftop Unit FDD • Retrocommissioning
Industry Trade Organizations	Incorporate duct-leakage prevention and best practices into future building standards and codes	<ul style="list-style-type: none"> • Aerosol Duct Sealing • Duct-Leakage Diagnostics • Ductwork in the Conditioned Space
	Establish industry standards for fault detection and diagnostics systems	<ul style="list-style-type: none"> • Building EIS • Continuous Commissioning • Packaged Rooftop Unit FDD
Utilities	Offer incentives to decrease the upfront costs of performance optimization and diagnostics systems	<ul style="list-style-type: none"> • Building EIS • Continuous Commissioning • Packaged Rooftop Unit FDD • Retrocommissioning

1 Introduction

The U.S. Department of Energy (DOE), Office of Energy Efficiency and Renewable Energy (EERE), Building Technologies Program (BT) commissioned this characterization and technology assessment of heating, ventilation, and air-conditioning (HVAC) systems for commercial buildings. The main objectives of this study *were* to:

- Identify a wide range of technology options in varying stages of technology development that could reduce commercial HVAC energy consumption;
- Provide in-depth analysis about selected technology options, including technical energy-savings potential, applicability to different building or HVAC equipment types, non-energy benefits, and barriers to market adoption.
- Develop suggestions for potential research, development and demonstration (RD&D) initiatives that would support further development of the most promising technology options, based on technical energy-savings potential, fit with DOE BT’s mission, and cost and complexity.

1.1 Report Organization

This report is organized as shown in **Table 1-1**.

Table 1-1: Report Organization

Section	Content/Purpose
Executive Summary	Top-level executive summary
1	Introduction
2	Technology Selection and Screening Processes
3	In-Depth Analyses of the Final Priority Technologies
4	Abridged Analyses of the Eight Early-Stage Technologies
5	Conclusions
References	References
Appendix A	Preliminary Analyses of 32 Technology Options
Appendix B	List of 182 Identified Energy-Saving Technologies
Appendix C	Technical Energy-Savings Potential of 57 Technology Options

1.2 Background

In 2002, DOE-BT commissioned a study [Roth, et al. (2002)] to characterize and assess opportunities for energy savings in commercial building HVAC systems with a specific focus on select technology options and its technical energy-savings potential and barriers to wide adoption. There have been much technological improvements and advances since 2002, including but not limited to: increased ubiquity of electronics control and relevant software; reduced costs of computing powers; availability of advanced sensors and controls; and advances in the field of material science. Furthermore, there is an increased level of consumer awareness of climate change and interest in energy-efficiency options. EnergyStar brand has become more visible and recognized, and has enabled utilities and government bodies to administer incentive

programs to might make energy-efficiency products more viable for end-users. On the other hand, the landscape surrounding the manufacturers has changed as well. Many foreign brands have entered into U.S. market over the last decade, and the presence of entrepreneurial activities and innovation from small start-ups continue to grow across many sectors.

According to *2011 Building Energy Data Book* [US DOE (2011)], the U.S. commercial-building sector consumed 18.35 quadrillion Btu’s (Quads) of primary energy in 2010.² Energy consumption associated with HVAC equipment (i.e., space heating, space cooling and ventilation) accounts for nearly 40% of the total energy consumption at 7.16 Quads (**Figure 1-1**).³

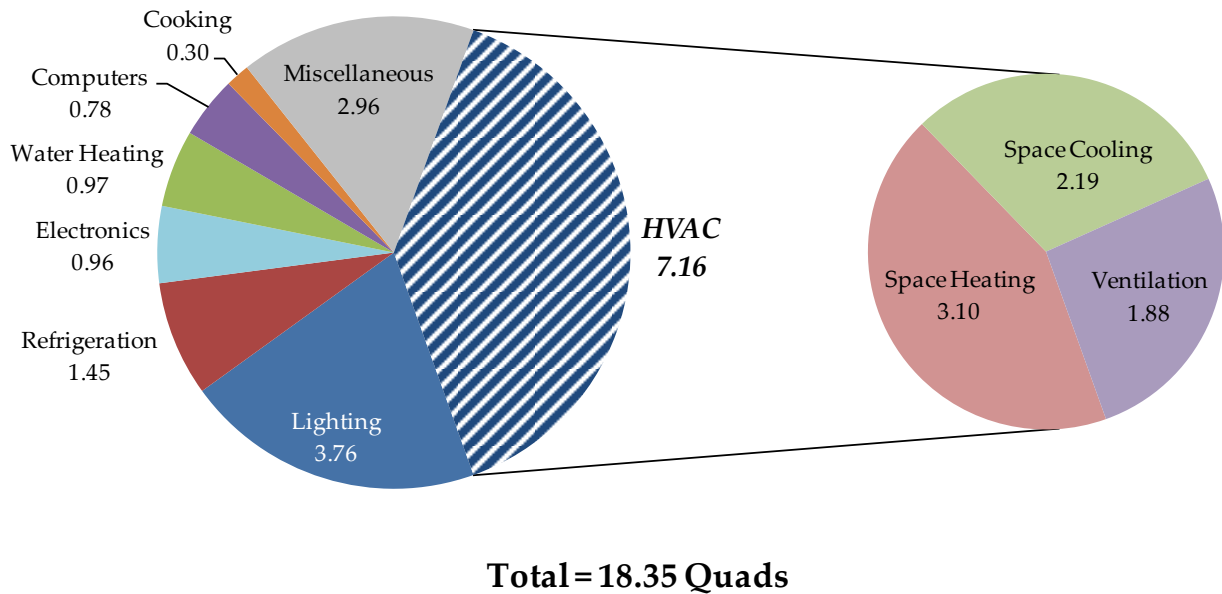

Figure 1-1: 2010 U.S. Commercial Building Sector Primary Energy Consumption (Quads)
Data Source: US DOE (2011)

Figure 1-2 presents the breakdown of HVAC energy consumption above by fuel type.

² Primary energy accounts for the losses in generation, transmission and distribution. We only account for these losses for electricity, as the transmission and distribution losses for natural gas and other fossil fuels tend to be small. Primary energy does not account for the losses associated with extraction.

³ According to the Building Energy Data Book, SEDS Adjustment (Energy attributable to the commercial buildings sector, but not directly to specific end-uses) account for 2.89 Quads, or over 15% of their estimate. For illustration purposes, we distributed the 2.89 Quads across all categories in proportion to energy consumption of each end use.

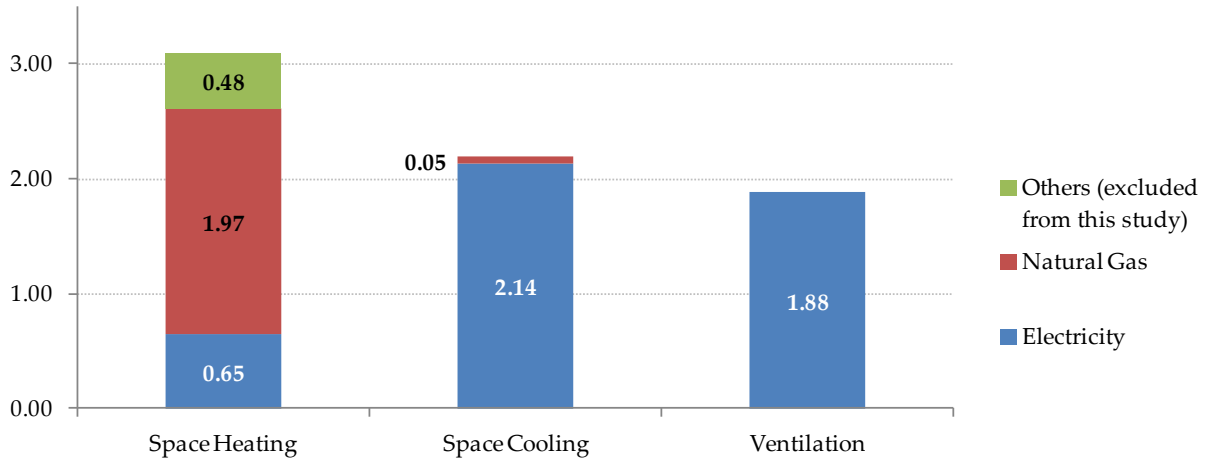

Figure 1-2: 2010 U.S. Commercial Building Sector HVAC Primary Energy Consumption, by Fuel Type
 Data Source: US DOE (2011)

This study focuses on electricity and natural-gas consumption associated with HVAC equipment in U.S. commercial-building sector, which totals to approximately 6.7 Quads annually.

Because some technology options are only applicable to certain types of HVAC equipment, we broke down the HVAC energy consumption by equipment type to estimate technical energy-savings potential⁴ of candidate technology options. We based our estimated energy-consumption breakdown on the *2003 Commercial Building Energy Consumption Survey (CBECS)* [US DOE (2005)], because the US DOE (2011) does not provide such a breakdown.

Figure 1-3 and Figure 1-4 present breakdowns of energy consumption for heating and cooling, respectively, by percentage of energy consumed in 2003. These annual energy consumption estimates form the basis for calculations of all technical energy-savings potential estimates in this report.⁵

⁴ Technical energy-savings potential is the theoretical national primary energy savings that could be achieved if all technically suitable installations are replaced with a particular energy-saving technology.

⁵ For certain technologies, these energy consumption estimates are further broken down by climate zones, building size, or both, based on 2003 CBECS data.

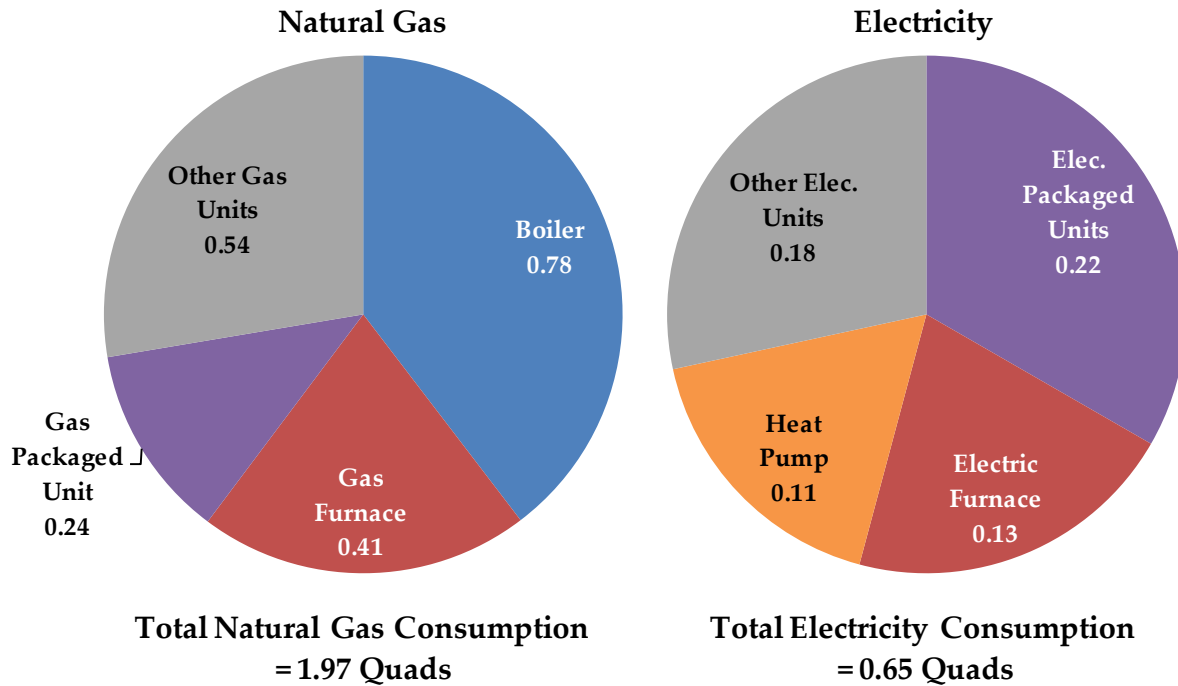

Figure 1-3: Percentage Breakdown of U.S. Commercial-Building Energy Consumption for Space Heating (Quads)

Data Sources: US DOE (2005), US DOE (2011)

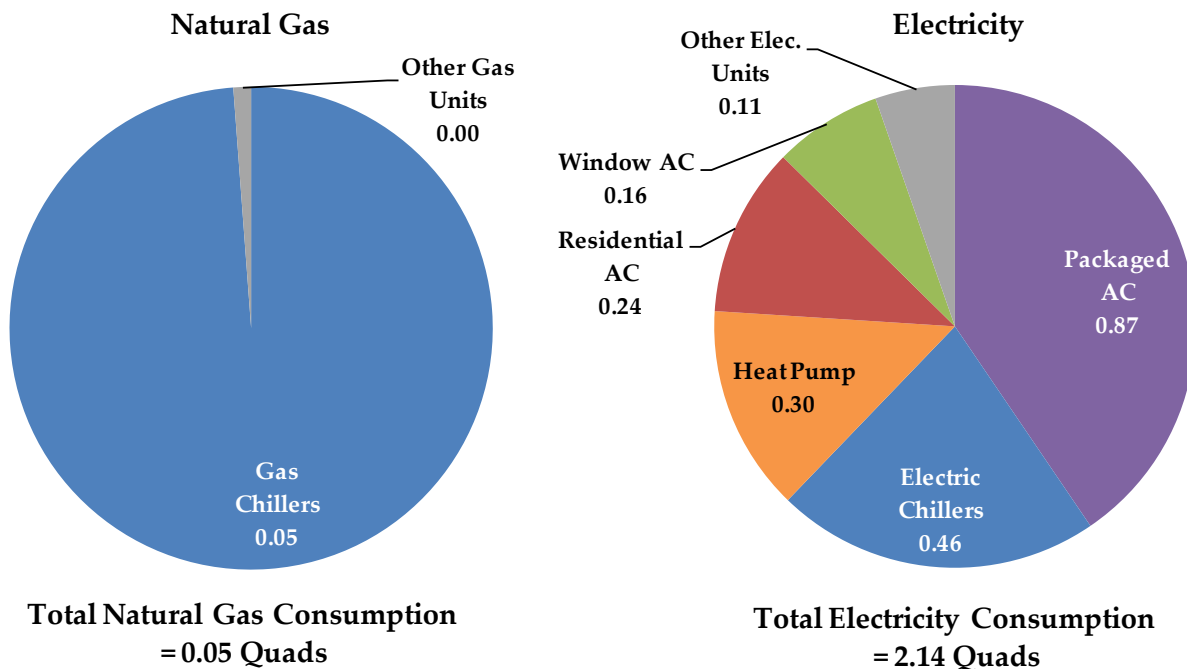

Figure 1-4: Percentage Breakdown of U.S. Commercial-Building Energy Consumption for Space Cooling (Quads)

Data Sources: US DOE (2005), US DOE (2011)

2 Technology Selection and Screening Processes

We examined a broad portfolio of technology options that could reduce energy consumption of commercial HVAC equipment. We then selected a subset of these technology options for further, more thorough evaluation. Finally, we distilled the portfolio to 17 priority technology options for in-depth analysis, including calculation of the technical energy-savings potential and evaluation of the state of technology development. **Figure 2-1** presents the overall flow of the technology selection, screening and assessment processes we followed.



Figure 2-1: Technology Selection and Screening Process

2.1 Develop initial list of technology options – Step 1

We first generated the initial, comprehensive list of technology options that could potentially improve the efficiency of commercial HVAC systems, resulting in 182 technology options (see Appendix A). We compiled this list without considering the economics, technical maturity, or the level of expected energy savings (if any). The only criterion for inclusion in this list was that the technology option must directly applicable to HVAC systems in commercial buildings, and have a potential to reduce HVAC energy consumption in some way. Direct impact excludes certain options such as real-time pricing, or renewable energy sources that we considered upstream of the HVAC system.

The technologies included in the initial list come from a variety of sources, including:

- HVAC Industry Publications, Organizations, and Websites (e.g., ASHRAE, AHRI, ACHR, and JARN)
- U.S. and International Government Organizations and National Laboratories (e.g., LBNL, California Energy Commission, NYSERDA, and ARPA-E)
- University Research (e.g., University of Maryland, Purdue University, University of Illinois, and Texas A&M University)
- HVAC Manufacturers (e.g., Trane, Daiken, Honeywell, and Johnson Controls)
- Gas and Electric Utility HVAC Programs (e.g., FPL, PG&E, and Colorado Springs Utilities)
- Internal Navigant Sources and HVAC Experts.

In addition to these we referenced Roth, et.al. (2002), a similar study commissioned by DOE BT in 2002.

After compiling the initial, comprehensive list of technology options, we conducted a literature review for each option to develop technical descriptions, energy-savings projections and identify equipment/systems to which technology option is potentially applicable.

2.2 Identify 50 to 70 technology options for further study – Steps 2 and 3

After completion of the initial list of 182 technology options, we developed a set of criteria to screen these options to identify those warranting further evaluation. We screened out 125 technology options because they did not meet one or more of the criteria listed below:

1. **Technology options that are outside the scope of this study:** Technologies considered outside the scope of this study included building design, envelope, and lighting strategies that reduced HVAC energy consumption indirectly. For example, improving building insulation reduces HVAC energy waste, but is not itself part of HVAC equipment or systems.
2. **Technology options at the end of their development cycle:** Technologies that are either widely practiced in the HVAC industry or otherwise fully developed into a commercially available product.
3. **Technology options with limited or no energy-savings impact:** Technologies having documented unit energy savings of less than 5% for the overall HVAC system, or less than 15% for a particular component, were not considered for further analysis. These technologies may reduce material, utilize alternative refrigerants, lower operating costs, etc.
4. **Technology options with limited applicability to commercial HVAC:** Technologies that do not have direct commercial HVAC applications, but are developed primarily for other purposes such as refrigeration, automotive A/C, industrial processes, etc. If these technologies were used for commercial buildings, they would apply only for niche applications.

We examined each of the 182 technology options based on our initial survey of their potential energy-efficiency impact, applications, and capabilities. After our screening process, 57

technology options remained (see **Table 2-1**), consistent with our goal of identifying 50 to 70 technology options for further study. These technologies span the many areas of HVAC systems including:

- **Components:** Technology options implemented within the HVAC equipment to improve the efficiency (individual parts)
- **Equipment:** Technology options to improve the way heating/cooling is generated (cooling cycles, heat pumps, etc.)
- **Systems:** Approaches/strategies to integrate HVAC equipment into the building while improving the performance
- **Operations/Maintenance:** Approaches/strategies to improve/assure the way the system is operated optimally
- **Controls:** Hardware/Software to optimize system performance (e.g. variable speed motor)

Table 2-1: 57 Technology Options Selected for Preliminary Analysis

Components (24)	Equipment (13)
Advanced Absorption Pairs	Centrifugal Bernoulli Heat Pump
Aerosol Duct Sealing	Cold Weather Heat Pump
Airfoil-Blade Centrifugal Fan	DEVap A/C
Copper Rotor Motor	Dual-Source Heat Pump
Electrohydrodynamic Heat-Transfer Enhancement	Hot-Dry Air-Conditioner
Fans Optimized for Every Application	Liquid Desiccant Air-Conditioner
High-Temperature Superconducting Motors	Magnetic Cooling Cycle
Metal Foam Heat Exchangers	Membrane Humidity Control with Advanced Active Desiccant Materials
Microchannel Heat Exchangers	Solar Enhanced Cooling
Nanofluids Enhanced Twisted Tape Heat Exchanger	Thermoelastic Cooling Cycle
Nanofluid Refrigerant Additives	Thermoelectric Cooling Cycle
Optimized Heat Exchangers	Thermotunneling Cooling Cycle
Passive Unsteady Airflow Mechanisms	Triple-Effect Absorption Chillers
Permanent Magnet Motors	
Smaller Centrifugal Compressors	
Small-Grooved Copper Tubes	
Smart Refrigerant Distributors	Controls (1)
Switched Reluctance Motors	Building Energy Information System
Thermoelectrically Enhanced Radiators	
Thermoelectrically Enhanced Subcoolers	
Turbo-Compressor-Condenser-Expander	

Variable-Pitch Fans	Systems (11)
Water-Cooled Condensers for Unitary Equipment	Chilled Beam Radiant Cooling
Zephyr Ceiling Tiles	Dedicated Outdoor Air System
Operations/Maintenance (8)	Demand-Controlled Ventilation
Continuous Commissioning	Ductwork in the Conditioned Space
Damper FDD	Mixed-mode Conditioning
Duct Static Pressure Reset and Control	Modular Chillers and Boilers
Duct-Leakage Diagnostics	Seasonal Thermal Energy Storage
Multilevel FDD	Solar Ventilation Preheating
Packaged Rooftop Unit FDD	Thermal Displacement Ventilation
Regular Maintenance	Unitary Thermal Energy Storage System
Retrocommissioning	VRV/VRF

2.3 Preliminary Analysis of the 57 technology options – Step 4

We further screened and analyzed the 57 technology options remaining after the initial screening process to better understand their technical energy-savings potential for commercial-building HVAC systems.

2.3.1 Overview of the Preliminary Analysis

After the initial screening, we performed a detailed analysis (“preliminary analysis”) of each of the 57 technologies selected to determine its potential for achieving HVAC energy savings in U.S. commercial buildings. For each option, we estimated the annual technical energy-savings potential in the U.S. commercial-building sector, and compiled detailed projections of the installed costs. Further, we identified barriers to market adoption and potential next steps toward greater market adoption for each of the technology options. Appendix B contains the preliminary analysis reports for the second-round technologies not selected for the final in-depth analysis.

We researched each technology option for:

1. **Projected Technical Energy-Savings Potential:** See Section 2.3.2.
2. **Projected Installed Costs:** We identified costs for each technology option as cited in the literature and by expert sources. For options currently in the research and development (R&D) stage, there may be significant uncertainties in current cost projections.
3. **Retrofit Potential:** We based ratings for retrofit potential on how difficult the technology option would be to implement in existing buildings, and on how invasive it might be once implemented. The categorized ratings as:

- a. **HIGH** retrofit potential: Easily swapped for existing components, added onto existing systems without excessive system changes, or installed as part of high efficiency replacement equipment.
 - b. **MEDIUM** retrofit potential: Could be implemented without major structural changes to the building, especially during a major renovation, or if certain infrastructure were already in place (e.g., pipes and ducts).
 - c. **LOW** retrofit potential: Requires major structural changes to the building (e.g., mixed-mode conditioning, which would require a major building redesign in a retrofit project).
4. **Peak-Demand Reduction and Other Non-Energy Benefits:** Non-energy benefits add value beyond gas or electric energy savings, and may benefit the environment, building owners, or occupants. They can be either quantitative or qualitative, and can vary greatly by system type and building application.
5. **Technical Maturity:** Technologies may fall in one of the following categories for technical maturity:
- a. Commercially available technology: Commercially available in the U.S.
 - b. Emerging technology: Limited/no availability in the U.S. market today, but may be commercially available outside the U.S., ready for commercialization in the U.S. without further R&D, or both
 - c. Short-term R&D technology: Not commercially available; requires resolution of a few product-development issues
 - d. Long-term R&D technology: Not commercially available; requires resolution of significant technical issues.

2.3.2 *Estimating Technical Energy-Savings Potential*

As discussed in Section 1.2, we compiled HVAC energy-usage data from the 2011 Building Energy Data Book and the 2003 CBECS⁶. First, we estimated the total commercial HVAC energy usage based on the Building Energy Data Book by energy source. We then divided this estimate into several segments based on 2003 CBECS, according to applicable equipment type, climate zone, building size, number of floors, and building type, to determine the total energy usage that the technology option would impact. We then judged the viable applications (market segments) for each technology.

To determine technical energy-savings potential, we multiplied the estimated percent unit energy savings by the total energy usage attributed to the technology.⁷ Technical energy-savings potential is the theoretical national primary energy savings that could be achieved if all technically suitable installations are replaced with a particular energy-saving technology. Unless specifically noted, we compared each technology to a baseline technology that just meets current

⁶ 2003 CBECS is the latest version available at the time we completed the preliminary analysis reports in Appendix B.

⁷ Where appropriate, we converted efficiency improvements into energy savings by relating the system efficiency to original energy use. For example, if efficiency improves 10%, energy use is divided by 110% (= 1.1), resulting in energy savings of 9.1% ($= 1 - \frac{1}{1.1}$).

codes and standards (or current typical practice) for U.S. commercial buildings. Appendix C presents the technical energy-savings potential for the 57 technology options presented in **Table 2-1** (but not including the eight early-stage technologies in Section 4).

For the purposes of this study, we estimated baseline technology performance from information obtained through our literature search.

We developed estimates of technical energy-savings potential based on the following scenarios:

1. All technology options currently undergoing R&D will be fully implemented in all practical applications.
2. All technology options are implemented in all five DOE climate zones unless specifically noted in our analysis. For most options, limited information exists on the variation of energy savings by climate zone.
3. Technology options applicable to packaged HVAC units are implemented only for buildings having one or two floors.
4. We used the following guidelines to rate retrofit potential:
 - a. High Retrofit Potential: Technology applies to 100% of the existing applicable installations
 - b. Medium Retrofit Potential: Technology applies to 50% of the existing applicable installations
 - c. Low Retrofit Potential: Technology applies to 10% of the existing applicable installations.

To determine the technical energy-savings potential associated with implementation of each technology, we assumed:

1. Each technology option is implemented properly so that it will achieve the expected energy performance.
2. Technology options requiring further R&D will achieve the energy performance currently predicted.
3. In cases where a technology option eliminates inefficiencies in existing equipment, equipment is restored to the performance levels expected with proper installation/operation/maintenance.
4. Fan energy use is 25% of all electricity consumed by the building's HVAC system.⁸
5. Energy savings attributed to electric-motor improvements apply to all electrically-driven HVAC equipment.

⁸ Based on estimates by the project team and Navigant subject-matter experts.

6. Improvements in heat-transfer performance have the following impacts on system energy savings: 10% heat-transfer improvement for a heat-exchanger component (e.g. condenser) translates to 1% overall system energy savings.⁹
7. Technology options impact peak-demand in proportion to their electrical energy savings, unless otherwise noted in our analysis.

2.4 Scoring criteria for the 57 technology options – Step 5

After analyzing the 57 technology options, we conducted another round of technology screening based on five criteria: Technical Energy-Savings Potential, Fit with DOE BT Mission, Cost/Complexity, Other Non-Energy Benefits, and Peak-Demand Reduction Potential. We assigned each criterion a weighting factor to reflect its overall importance. We scored each technology option (using a five-point scale) against each criterion, and calculated an overall score by multiplying the initial score by the weighting factor. **Table 2-2** shows the scoring matrix and weighting factors for each criterion.

Table 2-2: Technology Scoring Matrix

Screening Criteria	Wt. Factor	Score				
		1	2	3	4	5
Technical Energy-Savings Potential	35%	< 0.05 Quads/yr	0.05 – 0.1 Quads/yr	0.1 – 0.25 Quads/yr	0.25 – 0.5 Quads/yr	> 0.5 Quads/yr
Fit with DOE BT Mission	30%	Very weak fit	Moderately weak fit	Neither strong nor weak fit	Moderately strong fit	Very strong fit
Cost/Complexity	15%	Much higher cost/complexity	Moderately higher cost/complexity	Slightly higher cost/complexity	Potential for similar cost/complexity	Potential for lower cost/complexity
Other Non-Energy Benefits	15%	Provides few or no benefits	Likely to provide some modest benefits	Potential for significant benefits, but not well understood	Provides 1 or 2 quantified, well-documented benefits	Provides extensive, quantifiable, well-documented benefits
Peak-Demand-Reduction Potential	5%	No potential for reduction	0 – 5% reduction	5 – 10% reduction	10 – 15% reduction	> 15% reduction

⁹ According to Westphalen, et al. (2006). Actual savings based on heat transfer improvements for each case are out of the scope of this report unless noted.

1. **Technical Energy-Savings Potential:** See Section 2.3.2
2. **Fit with DOE/BT Mission:** We considered fit with the DOE/BT mission to be high when:
 - The technology is much more likely to achieve success, or likely to achieve success much faster, with DOE support
 - The technology’s technical risk is moderate to high, rather than low or very high
 - The technology, once developed, is likely to be embraced by major industry stakeholders
3. **Cost/Complexity:** Based on the incremental first cost of the technology option and the incremental complexity associated with installation, operation and maintenance of the technology option
4. **Non-Energy Benefits:** Based on the potential for the technology option to provide benefits beyond energy savings and direct emissions reduction, including but not limited to: improved comfort, improved indoor air quality, simplified maintenance, and reduced noise/vibration
5. **Peak-Demand-Reduction Potential:** Based on the technology option’s potential to reduce peak electricity demand. While electric energy savings generally provide reductions in peak demand, some technology options save energy preferentially during off-peak hours. Furthermore, technology options that save gas, but not electricity, have no impact on peak electrical demand.

We found a paucity of publicly available information for eight technology options that are still in the early stages of R&D. Because we were unable to find energy and cost savings estimates for these options, we could not quantitatively compare them to other options. Thus, we removed them from consideration for the final list of priority technologies, but recommend that DOE monitor their development. Section 4 contains summaries of our analyses for these eight technology options.

2.5 In-depth analysis of final priority technologies – Step 6

After establishing the scoring criteria for the second round of technology screening, we scored each of the 57 technology options based on our research and the input of HVAC experts within Navigant. Through this process, we identified the top technologies which clearly scored above the rest and best fit the goals of this report.

Table 2-3 presents the 17 technology options that we chose for the final in-depth analysis, along with their estimated technical energy-savings potential.

Table 2-3: The Final 17 Priority Technology Options and their Technical Energy-Savings Potential

Technology Category	Technology Option	Technical Energy-Savings Potential (Quads/yr)
Advanced Component Technologies	Smart Refrigerant Distributors	0.09
	Thermoelectrically Enhanced Subcoolers	0.20
Alternative Heating & Cooling Technologies	Liquid Desiccant A/C	0.21
	Magnetic Cooling Cycle	0.18
	Solar Enhanced Cooling	0.05
	Solar Ventilation Preheating	0.11
	Thermoelectric Cooling System	0.36
	Thermotunneling Cooling System	0.10
Thermal Distribution Systems	Aerosol Duct Sealants	0.61
	Demand-Controlled Ventilation	0.09
	Duct-Leakage Diagnostics	0.30
	Ductwork in Conditioned Space	0.24
	Thermal Displacement Ventilation	0.18
Performance Optimization and Diagnostics	Building Energy Information System	0.53
	Continuous Commissioning	1.11
	Packaged RTU FDD	0.08
	Retrocommissioning	0.87

3 In-Depth Analyses of the Final Priority Technologies

This section presents the in-depth analyses for each of the 17 priority technology options. Many of these technology options improve efficiency or enhance performance of common HVAC systems and problems, as categorized below:

- **Advanced Component Technologies** offset the energy consumption of conventional HVAC systems by optimizing the performance of critical components.
- **Alternative Heating and Cooling Technologies** provide heating or cooling more efficiently using novel techniques, often using renewable heating sources or non-vapor-compression refrigeration cycles.
- **Thermal Distribution Systems** consist of ducts, pipes, and other mechanisms that deliver space conditioning to building occupants; they eliminate duct leakage and maximize the performance of ventilation systems, which can significantly impact the energy consumption caused by poor thermal distribution.
- **Performance Optimization and Diagnostics** involve the monitoring, measurement, and benchmarking of HVAC system operations to uphold peak performance. Commercial HVAC systems lose efficiency over time from a number of sources but through diagnostics, monitoring and evaluation, operations can be optimized and maintained.

These categories represent the numerous areas in need of efficiency improvement and the diversity of strategies available to reduce HVAC energy consumption in commercial buildings. Table 3-1 provides each category with its corresponding technology options selected for final in-depth analysis.

Table 3-1: Final Priority Technologies by Category

Category	Applicable Technologies
Advanced Component Technologies	<ul style="list-style-type: none"> - Smart Refrigerant Distributors - Thermoelectrically Enhanced Subcoolers
Alternative Heating & Cooling Technologies	<ul style="list-style-type: none"> - Liquid Desiccant A/C - Magnetic Cooling Cycle - Solar Enhanced Cooling - Solar Ventilation Preheating - Thermoelectric Cooling Cycle - Thermotunneling Cooling Cycle
Thermal Distribution Systems	<ul style="list-style-type: none"> - Aerosol Duct Sealing - Demand-Controlled Ventilation - Duct-Leakage Diagnostics - Ductwork in Conditioned Space - Thermal Displacement Ventilation
Performance Optimization & Diagnostics	<ul style="list-style-type: none"> - Building Energy Information System - Continuous Commissioning - Packaged RTU FDD

Technology options featured in the same category may achieve a similar energy-saving goal through different approaches (e.g. Thermotunneling and Magnetic Cooling Cycles). For these technologies, the technical energy-savings would not normally be additive.

The remainder of this section consists of the in-depth analyses for the 17 priority technology options. Each analysis contains the following subsections:

- **Overview table:** Brief tabular description of the technology option, the estimated technical energy-savings potential, and three-step ratings (High, Medium, Low) of the technology's market readiness and the level of priority for DOE BT.
- **Summary:** Overview of the technology option
- **Background:** How the technology works, its practical uses, its limitations, why the technology offers an efficiency improvement over conventional technologies, and whether the new technology provides peak-demand reduction and other non-energy-related benefits.
- **Technical Energy-Savings Potential:** The technology's estimated energy savings based on technically reasonable level of penetration.
- **Cost and Complexity:** The estimated installed cost of the technology, as well as factors that may increase or decrease the complexity of HVAC system operation and maintenance.
- **Technical Maturity and Perceived Barriers to Market Adoption:** The technology's technical maturity, the key industry and R&D players contributing to the maturation of the technology, and the potential barriers to adoption.
- **Next Steps for Technology Development:** What needs to be done to commercialize the technology further.
- **References:** References consulted during our investigation.

3.1 Advanced Component Technologies

Advanced Component Technologies optimize the performance of critical components, offsetting energy consumption for conventional HVAC systems. This category includes:

- Smart Refrigerant Distributors
- Thermoelectrically Enhanced Subcoolers

3.1.1 Smart Refrigerant Distributors

Brief Description	Refrigerant maldistribution in evaporators lowers capacity and efficiency in vapor-compression systems. Smart refrigerant distributors sense and direct the proper amounts of refrigerant to each evaporator circuit maintaining optimum performance.		
Technical Energy-Savings Potential (Quads/year)	Market Readiness	DOE Priority	
0.09 Quads/year	Low	Medium	

Summary

Smart refrigerant distributors control the amount of refrigerant each evaporator circuit receives to maintain capacity and performance for vapor-compression HVAC systems. The electronic distributor valves dynamically react to refrigerant maldistribution caused by rapid changes in operating conditions, non-uniform airflow through the evaporator, practical tolerances achievable in coil fabrication/assembly, and other sources. Extensive research has confirmed the deleterious performance effects of maldistribution and how intelligent distribution controls can restore capacity. These devices will take the place of current expansion and distribution components in high-efficiency packaged units. Products are emerging for residential applications, but commercial equipment requires significant research to overcome its more complex evaporator circuitry.

Table 3-2 presents a summary overview of smart refrigerant distributors for commercial HVAC equipment.

Table 3-2: Summary of the Characteristics of Smart Refrigerant Distributors

Attribute	Value	Comments
Systems Impacted	Unitary vapor-compression systems	
Fuel Type	Electricity	
Relevant Annual Energy Consumption	0.98 Quads/yr	
Technical Energy-Savings Potential	0.09 Quads/yr	
Peak Demand Reduction	Low	Varies according to system conditions
Technical Maturity	R&D (short term)	Product for residential systems, but significant research still needed for commercial
Retrofit Potential	High	Almost all unitary systems would benefit. Will be included first in packaged equipment.
Non-energy Benefits	<ul style="list-style-type: none"> - Improved capacity control - Less refrigerant - Lower failure rate - FDD capabilities 	
Most Promising Applications	<ul style="list-style-type: none"> - Integrated into advanced OEM packaged units 	
Next Steps for Technology	<ul style="list-style-type: none"> - Development of emerging products for commercial equipment - Conduct testing for various pairings of refrigerants and evaporators 	

Background

- Technology Description

In unitary vapor-compression HVAC systems, a two-phase refrigerant enters an evaporator to extract heat from flowing air, boiling the refrigerant so that the conditioned air can cool a space. The refrigerant coils of the evaporator are often split into multiple circuits to reduce pressure drop and provide even conditioning across the evaporator face. Typically, evaporators use distributors (aka spiders) and creative circuiting to divide the refrigerant among circuits with the hope that each circuit achieves similar levels of superheat and the refrigerant boils completely. This can be done in one of 3 ways as shown in **Figure 3-1** below:

- Multiple circuits split across the evaporator face
- Multiple evaporator rows each containing a single circuit
- Combination of circuits split across the face and over rows

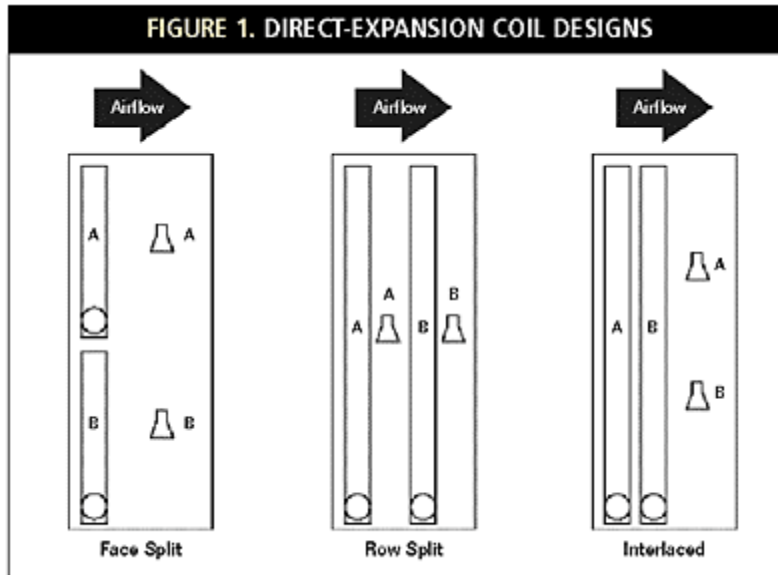

Figure 3-1: Direct-Expansion Evaporator Coil Designs

Source: Process Heating (2004)

This uniform distribution is difficult to maintain over a wide range of conditions and refrigerant maldistribution can greatly affect evaporator capacity. Maldistribution can occur from both refrigerant-side and air-side causes, including:

- Impurities in the refrigerant that buildup in evaporator circuits
- Non-uniform temperature gradients in airflow
- Fouling or wear to the evaporator coils/fins or distribution mechanism
- Uneven airflow distribution caused by duct or evaporator shape (especially important in “A” coils)
- Physical blockages in or around the evaporator reducing airflow
- Temperature fluctuations outside of standard design conditions

To reduce the environmental impact of refrigerant escaping from vapor-compression systems, manufacturers have decreased the amount of refrigerant contained in each unit. Lower amounts of refrigerant exacerbate the impacts of maldistribution causing system behavior and performance to change more rapidly. During maldistribution disturbances, efficiency is lost when capacity drops while consuming the same amount of fan and compressor energy. Smart refrigerant distributors help maintain system capacity and efficiency by redirecting refrigerant flow so that each evaporator circuit receives the optimum amount.

Maldistribution causes some evaporator circuits to boil faster than others. Two-phase heat transfer rates are much higher than single-phase, allowing more energy to be extracted from the air and capacity maintained. Also, when an evaporator circuit is primarily gaseous, the temperature difference between air and refrigerant is lower, reducing performance. In a non-uniform event such as compressor shut-off or an airflow gradient over the evaporator face, system capacity drops as different refrigerant circuits boil at different rates. Smart refrigerant

distributors are able to detect the change in operating conditions and modulate the amount and quality of refrigerant entering each circuit to optimize performance.

Traditionally an orifice or thermostatic expansion device controls refrigerant distribution.

Figure 3-2 below illustrates a typical evaporator refrigerant distribution system. A valve expands regulating the flow of refrigerant in the system and uses a static distributor to divide refrigerant among the evaporator circuits. The thermostatic expansion valve regulates flow according to a temperature sensor (usually a bulb) placed on the evaporator outlet manifold to measure the amount of superheat.

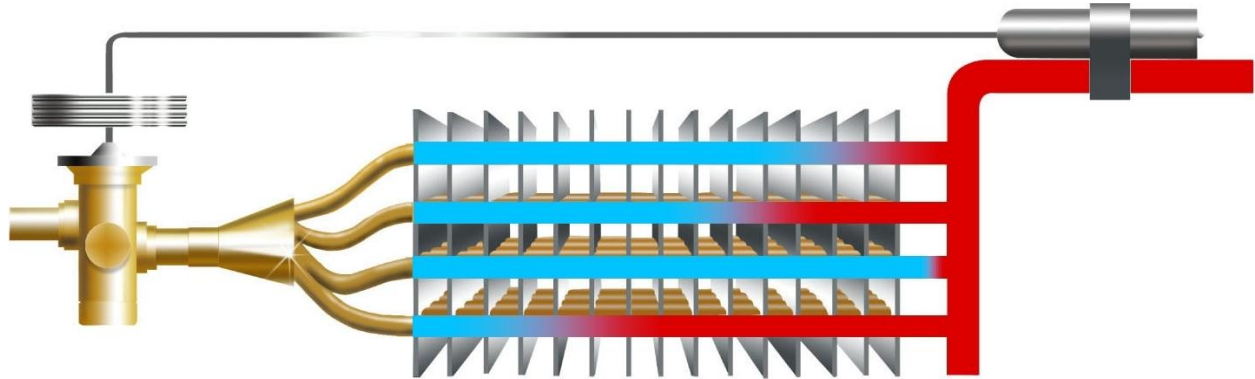

Figure 3-2: Evaporator with Non-Optimized Refrigerant Distribution

Source: Misfeldt (2010)

Figure 3-3 below illustrates the integrated design of smart distributors.

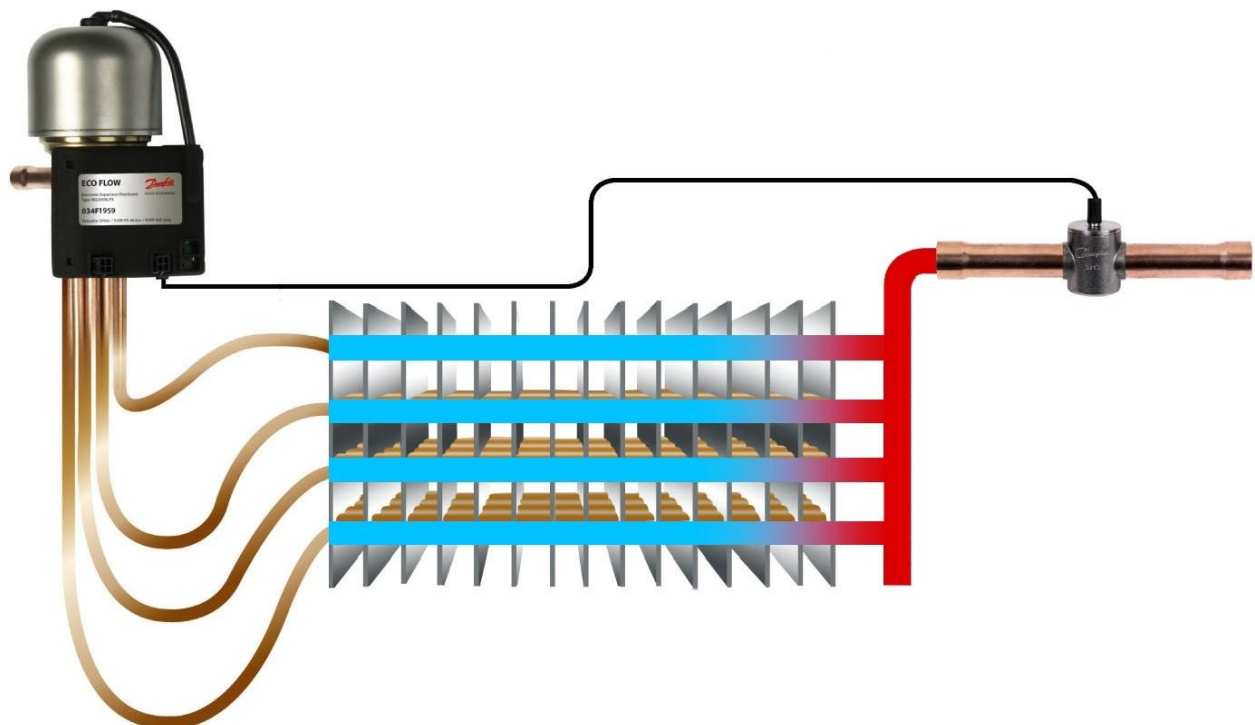

Figure 3-3: Evaporator with Optimized Refrigerant Distribution

Source: Misfeldt (2010)

- *Energy-Efficiency Advantages*

Smart refrigerant distributors use digital flow valves and sensors to direct the optimum amount of refrigerant to each circuit, maintaining system efficiency. A specialized control algorithm determines evaporator conditions through inputs from superheat sensors and other system parameters. These superheat sensors are either individually located on each circuit or collectively on the downstream manifold. The smart refrigerant distributor then modulates the precise flow of refrigerant to each individual circuit according to the algorithm. The distributor either has a single valve rotating among the circuits, or each circuit has its own dedicated flow valve. With each circuit receiving the optimum amount of refrigerant, capacity can be maintained over a wide variety of conditions. Also, the distributors also can be connected to fault detection and diagnostics (FDD) systems and to provide the evaporator status to assist service technicians when a problem arises.

- *Peak Demand Reduction and Other Non-Energy Benefits*

When maldistribution occurs during peak demand periods, the capacity and efficiency losses contribute to an increase in peak demand that can be minimized by smart distributors. Again, these peak demand benefits will vary with individual HVAC system conditions.

A smart distributor that modulates the allocation of refrigerant circuits can provide better capacity control and comfort in a wide range of conditions, especially during non-uniform airflow events. Proper control of evaporators allows manufacturers to use less refrigerant (with the associated environmental benefits) while maintaining good refrigerant distribution in evaporator circuits. These computer controlled devices can communicate with the rest of the HVAC system and provide FDD capabilities for the evaporator.

Energy-Savings Potential

- *Potential Market and Retrofit Applications*

Almost all commercial unitary HVAC systems could benefit from smart refrigerant distributors. This technology will be primarily employed in high-efficiency replacement equipment. Because the smart distributor needs to be tuned for each evaporator design, this technology will first be deployed in high volume models of unitary equipment. These devices could be retrofit onto existing evaporators by replacing the current expansion valves and distributors. Due to the time and effort it takes to reclaim the refrigerant, change the valve and distributor, evacuate the line, and recharge the system, costs will likely be high making retrofit less practical.

- *Energy Savings*

Based on an analysis of its potential impact on HVAC systems in the U.S., this technology would save 0.09 Quads of electricity per year. Each HVAC system will be affected differently by refrigerant maldistribution, and expected system energy-efficiency gains are difficult to quantify. The smart refrigerant distributors have been used effectively to reduce performance losses caused by internal and external disturbances and maldistributions when they do arise. The potential benefit is directly tied with the amount of deviation the system experiences from the design conditions. Because the effect of maldistribution on capacity is well documented and maldistribution is at least qualitatively known to occur in practice, smart distributors should provide sizable unit energy savings.

Payne and Domanski (2002) tested a variety of evaporators with unregulated maldistributions and found a 30+% drop in capacity without optimized refrigerant distributors.

Jin et al. (2006) found that refrigerant flow maldistributions reduced capacity 5-15% in aluminum brazed evaporators.

Kaern and Elmegaard (2009) tested a simplified two circuit fin-and-tube evaporator and found an 11-15% drop in capacity due to refrigerant maldistribution. When non-uniform airflow passed over the evaporator, capacity fell 46-80%. Smart distributors were able to maintain 96% of peak capacity during these events.

Brix (2010) found that a refrigerant maldistribution caused a 20% capacity loss in a minichannel evaporator using R-134a and that non-uniform airflow caused a 20-80% capacity loss.

Cost and Complexity

This technology would be the successor to advanced expansion valves using modulating stepper motors for more precise refrigerant control. Where these devices only control the overall flow to the evaporator, the smart distributor can modulate the amount of refrigerant to each circuit individually. The cost premium associated with smart distributors should be minimized due to its inclusion in premium-efficiency models.

Perceived Barriers to Market Adoption

This technology is not commercially available, and there are a few product development issues to be resolved through short-term R&D activities. Much work has been done to study the effects of refrigerant or air maldistributions across evaporators, but few have looked into how to maintain capacity in those instances. Laboratory methods to mitigate capacity losses using multiple expansion valves and distributors have experienced limited success. Control strategies developed from algorithms using evaporator and overall all system conditions are specific to each evaporator and require an intensive design process.

Next Steps for Technology Development

Danfoss A/S has developed an intelligent distributor valve called EcoFlow scheduled to debut in late 2011. **Figure 3-4** and **Figure 3-3** above both show the EcoFlow. The EcoFlow is currently undergoing extensive manufacturer testing for residential applications. Specifically designed for packaged units in the 1-7 ton range, EcoFlow will modulate refrigerant distribution and maintain capacity during disturbances, especially caused by A-shaped residential evaporators. Testing has revealed up to a 1.5 SEER improvement for systems equipped with EcoFlow. The device will feature FDD capabilities for service technicians and be available in premium- and moderately-priced residential split-systems.



Figure 3-4: Danfoss EcoFlow Refrigerant Distribution Device

Sources: Tryson (2010) and Danfoss (2009)

EcoFlow utilizes a single superheat sensor placed downstream of the evaporator, continuously measuring the changing evaporator conditions as feedback for its sophisticated control logic. An internal expansion disk powered by a digital motor rotates among the evaporator circuits to precisely distribute refrigerant. The EcoFlow's distribution controls continually adjust the refrigerant flowing to each evaporator circuit through the following strategy:

This method of adaptive distribution works as a result of the non-linear behavior of the superheat of the refrigerant, which temperature at the beginning of the dry-zone increases rapidly, and slowly increases towards the air-inlet temperature. Continuous calculations form the basis of a hypothesis about the refrigerant level in each circuit. The EcoFlow tests the hypothesis by adding slightly more refrigerant to one circuit, while reducing the amount to the others. If the superheat measured in the manifold drops, then it is concluded that the dry zone has been reduced and less refrigerant is added to the circuit on the next cycle. On the other hand, if the resulting superheat increases, it is an indication that the circuit that received more refrigerant had a larger dry-zone. The valve will then distribute more refrigerant to this circuit until the superheat reduces. The valve then repeats the action to track changes, and then starts the process again in a continuous cycle. (Danfoss, 2009).

Danfoss A/S chose to introduce this technology in residential equipment due to the success of their advanced electronically-controlled expansion valve and the relative simplicity of residential equipment. The product is currently under development for R-410a applications, but should be compatible with all common refrigerants. Commercial equipment contains many complex refrigerant circuits often using multiple compressors and evaporators that require more sophisticated control algorithms. Success in the residential market should drive the development of this technology for commercial applications.

Table 3-3 presents the potential next steps for smart refrigerant distributors to gain greater market attention and acceptance.

Table 3-3: Recommended Next Steps for the Development of Smart Refrigerant Distributors

Initiatives	Lead Organization(s)
Develop this technology into a cost-effective component for use in commercial HVAC systems	DOE, Manufacturers
Conduct field testing with a variety of refrigerant types and evaporator designs	DOE, Manufacturers

References

Brix, Wiebke. 2010. “Modelling Refrigerant Distribution in Minichannel Evaporators.” Technical University of Denmark. Department of Mechanical Engineering.

Danfoss. 2009. “EcoFlow Innovation Presentation.” Danfoss A/S. Retrieved from http://www.tholander.dk/media/1885/ecoflow_brochure_090831_lowres_opslag.pdf.

Jin et al. 2006. “Refrigerant Distribution in Evaporator Manifolds.” ASHRAE Technical Committee TC 8.4. ASHRAE 1260-TRP.

Kaern and Elmegaard. 2009. “Analysis of Refrigerant Mal-Distribution in Fin-and-Tube Evaporators.” Danske Kølledage 2009, Kompendie. p 25-35.

Linde, John. 2005. “Construction of Test Facility to Measure and Visualize Refrigerant Maldistribution in Multiport Evaporator Headers.” University of Maryland. Department of Mechanical Engineering.

Misfeldt, Ib. 2010. “Flow Mal-distribution on Evaporators.” Technical University of Denmark. Department of Mechanical Engineering. Retrieved from http://www.mek.dtu.dk/English/Research/PhD%20Projects/phd_martinryhik%20C3%A6rn.aspx

Nelson, Bruce. 2004. “Direct-Expansion Evaporator Coil Design.” Process Heating. March 1, 2004.

Payne and Domanski. 2002. “Potential Benefits of Smart Refrigerant Distributors.” Air-Conditioning and Refrigeration Technology Institute. ARTI-2 1 CW605-200-50-01.

Staub, Jeff. 2011. Danfoss North America Refrigeration & Air-Conditioning. Personal Communication. June 2011.

Tryson, Lisa. 2010. “Most Valves Expand Your Refrigerant – Danfoss EcoFlow Expands Your Options.” Danfoss North America. Retrieved from http://www.danfoss.com/North_America/NewsAndEvents/News/Most-Valves-Expand-Your-

[Refrigerant-%E2%80%93-Danfoss-EcoFlow%E2%84%A2-Expands-Your-Options/FCD379DC-6329-43B8-838A-134F018D6D44.html](https://www.danfoss.com/~/media/Products/Refrigerant-%E2%80%93-Danfoss-EcoFlow%E2%84%A2-Expands-Your-Options/FCD379DC-6329-43B8-838A-134F018D6D44.html).

3.1.2 Thermoelectrically Enhanced Subcooling

Brief Description	Thermoelectric (TE) devices convert electricity to a thermal gradient that can provide efficient cooling for small temperature lifts or cooling loads. A subcooler incorporating TE stages lowers the temperature of condensed refrigerant and raises overall system capacity and COP.	
Technical Energy-Savings Potential (Quads/year)	Market Readiness	DOE Priority
0.20 Quads/year	Low	High

Summary

Thermoelectric (TE) devices convert electricity into a thermal gradient that can enhance condensed-liquid subcooling for vapor-compression HVAC systems. The small electrical power requirement of TE subcoolers increases evaporator capacity and COP without additional refrigerant flow and the associated compressor power requirement. These subcoolers would be featured in packaged HVAC equipment configured to achieve high-efficiency with the added benefit of increased capacity control. Research has shown the effectiveness of this technology for HVAC applications to both raise capacity and COP, but challenges remain to create a reliable and cost-effective subcooler. Further prototype development and field testing should determine the most beneficial design and manufacturing practices for subcooling HVAC systems.

Table 3-4 presents a summary overview of thermoelectrically enhanced subcooling for commercial HVAC equipment.

Table 3-4: Summary of the Characteristics of Thermoelectrically Enhanced Subcooling

Attribute	Value	Comments
Systems Impacted	Subcoolers for vapor-compression HVAC systems	
Fuel Type	Electricity	
Relevant Annual Energy Consumption	2.25 Quads/yr	
Technical Energy-Savings Potential	0.20 Quads/yr	
Peak Demand Reduction	Medium	- Significant capacity and COP improvements for A/C
Technical Maturity	R&D (short-term)	- Although materials research is long-term, TE subcoolers can use current technology
Retrofit Potential	High	- Component in unitary equipment
Non-energy Benefits	<ul style="list-style-type: none"> - Better part-load capacity control - Reduces equipment physical size - Lower refrigerant charges 	
Most Promising Applications	<ul style="list-style-type: none"> - Packaged HVAC equipment 	
Next Steps for Technology	<ul style="list-style-type: none"> - Continue laboratory research to determine the best orientation of the TE subcooling devices that maximize heat transfer - Further advancements in TE technology including improving cost-effective, high-ZT devices - Field testing of various HVAC systems with TE subcoolers to identify optimum configurations and demonstrate reliability 	

Background

- *Technology Description*

Thermoelectric devices (TE) provide cooling by converting an electrical voltage difference into a temperature difference across a specialized material. The Peltier effect occurs when electric current passes through two dissimilar metals connected by a common junction resulting in both a hot side and a cold side. Typically these metals are n-type and p-type semiconductors with properties that allow for useful solid-state cooling. **Figure 3-5** demonstrates the relationship between temperature lift (the difference between the hot/cold surfaces), efficiency (COP), and the power applied to the TE device. As the applied electrical power increases, the temperature lift increases exponentially although the efficiency of the TE device decreases rapidly. Balancing these three key values determines the effectiveness of adding TE devices to thermal systems. Select applications such as a subcooler enhanced with TE devices could enhance COP for vapor-compression HVAC systems.

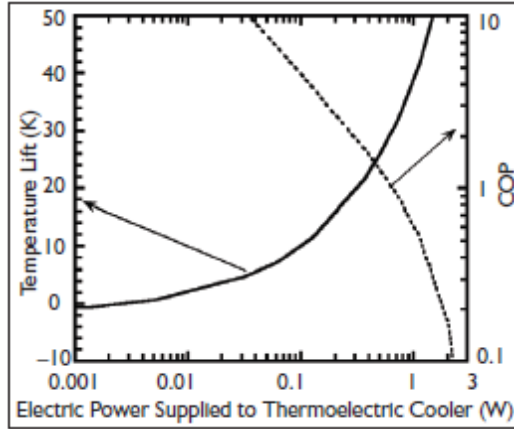

Figure 3-5: Temperature Lift and COP of a Sample TE Device vs. Applied Power

Source: Radermacher et al. (2007)

Using TE devices for subcooling could benefit HVAC systems more efficiently than conventional ambient or mechanical subcoolers. Subcoolers reduce the refrigerant enthalpy entering (and leaving) the expansion device, boosting cooling capacity without additional input from the primary compressor. Ambient subcoolers reject refrigerant heat to the lower temperature of a surrounding medium (usually air), but lose effectiveness during warm conditions. Mechanical subcoolers use smaller, secondary vapor-compression circuits that are too large, complex, and inefficient for low-temperature lift ($\sim 10^{\circ}F$) applications. Typically, TE devices have a high COP for low-temperature lifts supplementing cooling capacity with less additional energy.

When designed correctly, the TE subcooler provides efficient capacity gains when the energy consumed by the TE is less than the additional compressor requirement to achieve the same capacity boost. The additional capacity delivered by the efficient TE device outweighs other subcooling methods because of the specific low-temperature lift characteristics. The electricity for the TE can be provided either from the HVAC equipment power supply or from a TE generator. A TE generator creates electricity from an existing temperature gradient. The compressor on HVAC systems creates large amounts of waste heat that can be captured by imbedded TE generators (220a) to power the TE subcooler (220b) as seen in **Figure 3-6**. The COP of a system featuring a TE-enhanced subcooler would increase even further because there is no external power requirement for the subcooler.

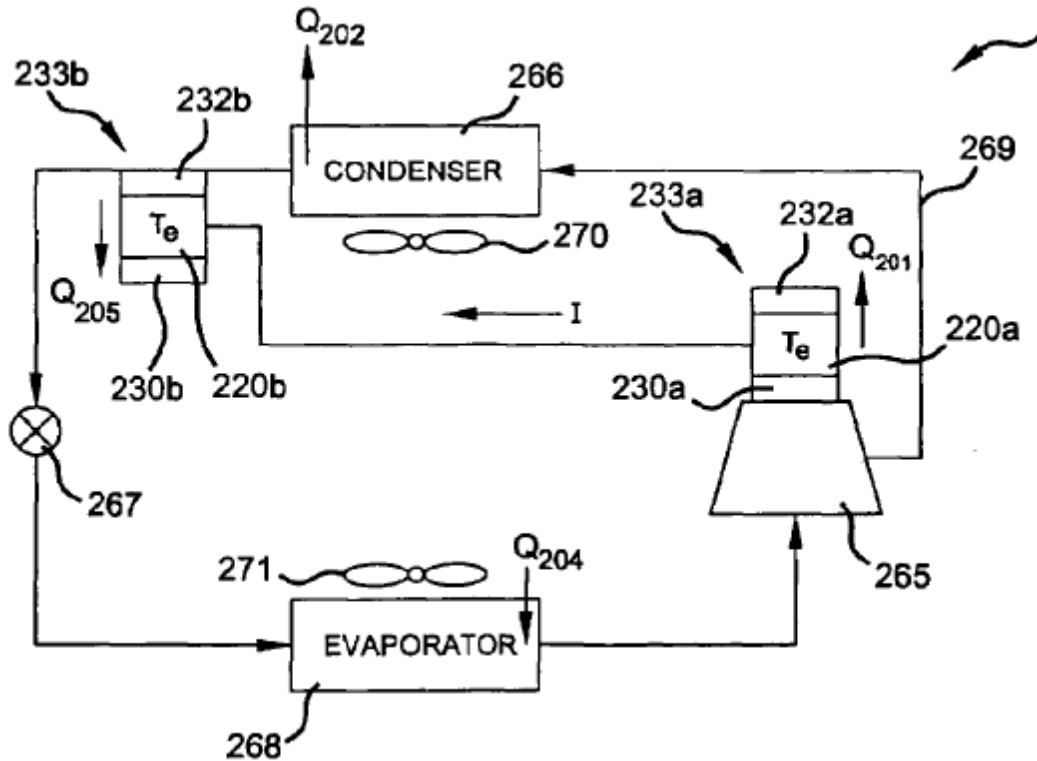

Figure 3-6: Vapor-compression System with TE Subcooler Powered by TE Generator
 Source: Akei et al. (2007)

Depending on the size and requirements of the air-conditioning system, the TE subcooler could consist of one or many TE devices staged in series as seen in **Figure 3-7**. Because the efficiency and temperature lift of the TE device varies independently with the applied electrical power, the TE subcooler can vary its output to accomplish different goals. Primarily, the TE subcooler will supply a moderate increase in cooling capacity very efficiently, which significantly raises overall system COP. When necessary, the TE device can greatly increase cooling capacity with an additional electricity requirement much less than would be required by the compressor. Because the TE would provide this additional capacity more efficiently, the main compressor could be downsized.

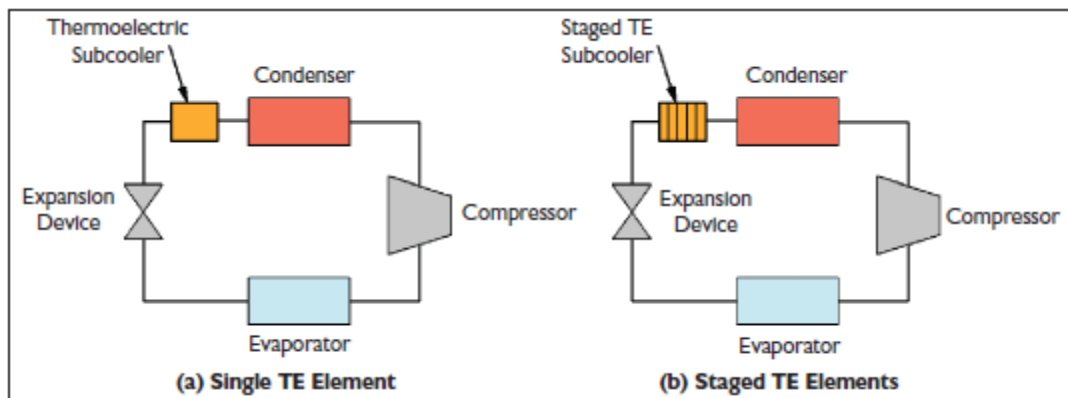

Figure 3-7: Vapor-compression Systems with TE Subcoolers
 Source: Radermacher et al. (2007)

The TE subcooler acts as an additional heat exchanger using the cold side of the device to pick up heat from the refrigerant and expel it to a sink through the hot side. Proper heat rejection from the hot side prevents heat buildup in and around the thin TE material, maintaining the effectiveness of the cold side. Active systems using fans and pumps, or passive methods such as natural convection with fins expel heat from the TE device. **Figure 3-8** demonstrates a cross-section of a prototype TE subcooler.

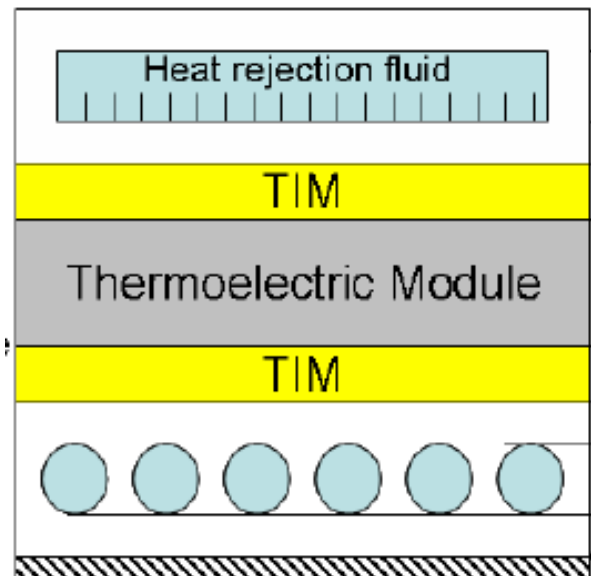

Figure 3-8: Prototype TE Subcooler Cross-section
Source: Schoenfeld (2008)

The condensed refrigerant passes through a tube heat exchanger connected to the cold side of the TE device by a thermal interface material (TIM). Electricity to the TE device creates the usable thermal gradient and lowers the enthalpy of the refrigerant. The hot side of the TE device rejects heat to a sink, continuing the efficient cooling.

- *Energy-Efficiency Advantages*

Because of their unique characteristics, TE devices used for refrigerant subcooling provide additional cooling capacity using less energy than would be required by a compressor. Overall system COP increases due to the TE-enhanced subcooling.

- *Peak Demand Reduction and Other Non-Energy Benefits*

The overall system efficiency improvement provided by TE subcoolers lowers peak demand for air-conditioning. Using TE to enhance heat transfer in conventional HVAC systems could reduce the physical size of equipment and amount of refrigerant needed.

Energy-Savings Potential

- *Potential Market and Retrofit Applications*

TE-enhanced liquid subcoolers could be retrofit into existing equipment, but would require an analysis of the heat exchanger and compressor operation. TE enhancements would be integrated into high-efficiency unitary equipment.

- *Energy Savings*

Additional capacity from the subcooler reduces the size and energy requirements for other components, like the compressor. TE-enhanced subcoolers provide limited capacity control for better part-load operation. Based on an analysis of its potential impact on HVAC systems in the U.S., this technology would save 0.20 Quads of electricity per year.

Radermacher et al. (2007) found that TE subcooling would increase system efficiency by 10-30%. They estimated that a system using R-134a could anticipate a 3.5% increase in COP for every 9 °F of subcooling.

Schoenfeld (2008) built and tested a number of TE subcoolers for a carbon dioxide transcritical refrigeration system. By modifying the configuration and applied power to the TE subcoolers, he operated the system for most efficient capacity addition (highest COP) and maximum capacity increase. With the addition of the TE subcooler, maximum COP increased by 10% while overall capacity could increase by 24% with nominal COP change.

Cost and Complexity

Because TE subcoolers are in the development stage, little information is available regarding their cost. Radermacher et al. (2007) notes that the additional costs of the TE material, power supply, and manufacturing would be significant. Optimization of the heat exchanger, airflow, and compressor selection would be needed to integrate the TE enhancements. As stated earlier, the capacity increases would allow for smaller components to be used, offsetting the cost of the TE subcooler somewhat.

Technical Maturity and Perceived Barriers to Market Adoption

This technology is not commercially available, with a few significant technical issues that require short-term R&D efforts before they are resolved. Each TE subcooler must be specifically configured for the applied system to ensure compatibility with the other system components. Material and manufacturing limitations pose problems for the use of TE devices in many HVAC applications¹⁰. The TE figure of merit (ZT) corresponds to the COP performance for the semiconductor material. Advanced TE materials have experimentally shown to achieve a ZT of 3 with a theoretical limit of approximately 5. Today's readily available TE devices have a ZT around 1, but are sufficient for subcooling applications (Schoenfeld, 2008).

Next Steps for Technology Development

Table 3-5 presents the potential next steps for TE subcooling to gain greater market attention and acceptance.

¹⁰ We selected the thermoelectric cooling cycle as a technology for in-depth analysis. The technology is described in Section 3.2.5.

Table 3-5: Recommended Next Steps for the Development of Thermoelectrically Enhanced Subcooling

Initiatives	Lead Organization(s)
Continue laboratory research to determine the best orientation of the TE subcooling devices that maximize heat transfer	DOE, University Research
Continue research on high-ZT devices achieving a greater COP and lowering manufacturing costs of the TE materials	DOE, Manufacturers, University Research
Conduct field testing of prototype TE subcoolers in manufactured equipment to determine operational reliability and best practices	DOE, Manufacturers, Industry Organizations

References

Akei et al. 2007. “Vapor Compression Circuit and Method Including a Thermoelectric Device.” U.S. Patent No: US 7,240,494 B2. July 10, 2007.

Radermacher et al. 2007. “Integrated Alternative and Conventional Cooling Technologies”. ASHRAE Journal. October, 2007. p 28-35.

Radermacher, Reinhard. 2011. Personal Communication. June 2011.

Radhakrishnan et al. 2009. “Thermoelectric Device Based Refrigerant Subcooling.” U.S. Patent Application Publication. Pub. No: US 2009/0266084 A1. Oct. 29, 2009.

Schoenfeld, Jonathan. 2008. “Integration of a Thermoelectric Subcooler into a Carbon Dioxide Transcritical Vapor Compression Cycle Refrigeration System.” University of Maryland.

Yang et al. 2008. “Thermoelectric Technology Assessment: Application to Air Conditioning and Refrigeration.” HVAC&R Research. Volume 14, Number 5. September 2008.

3.2 Alternative Heating & Cooling Technologies

Alternative Heating & Cooling Technologies provide thermal conditioning using novel materials and strategies that use renewable or non-vapor-compression heating and cooling sources. To be included in this category, a technology option must at least have the potential to be more energy efficient than conventional vapor-compression cooling. This category includes:

- Liquid Desiccant A/C
- Magnetic Cooling Cycle
- Solar Enhanced Cooling
- Solar Ventilation Preheating
- Thermoelectric Cooling Cycle
- Thermotunneling Cooling Cycle.

3.2.1 Liquid Desiccant Air Conditioner

Brief Description	Liquid desiccant air conditioners remove latent heat from incoming supply air by using liquid desiccants. Liquid desiccants remove moisture by attracting (and thus removing) water in the air. The desiccant is then heated to remove the moisture, enabling a full cycle to be run. This technology is most effective in humid regions with small sensible heat loads; it can also be used as a supplemental system to reduce latent loads on air-conditioning equipment.	
Technical Energy-Savings Potential (Quads/year)	Market Readiness (1 – 3)	DOE Priority (1 – 3)
0.21 Quads/year	Medium	Medium

Summary

Liquid desiccant air conditioners provide cooling by removing moisture from incoming air. They can be either the primary source of cooling (in regions with high latent loads and low sensible loads) or as a secondary system assisting the main cooling plant. Liquid desiccant air conditioners are only effective in humid climates, but have the potential to save around 20-30% of typical energy consumption. They have the potential to be used in all building types.

Liquid desiccant air conditioners use liquid desiccants to remove moisture from the air, and then use a regenerator to remove the moisture; this second step enables the air-conditioner to re-use the spent desiccant. The thermal heat needed to regenerate the desiccant can come from a gas-heating heating, from waste heat, or from a solar-thermal array.

At least one company has commercialized a low-efficiency system, and field testing by AIL Research is also on-going. Dieckmann et al. noted that liquid desiccant air conditioners can have a cost premium of 65% over current systems. Current liquid desiccants used in commercial systems are corrosive, and investigation into non-corrosive options is needed. Further

development and field-testing of high-efficiency regeneration is also needed to increase the overall efficiency of the system.

Table 3-6 summarizes the characteristics, potential energy savings, and research status of this technology.

Table 3-6: Summary of the Characteristics of Liquid Desiccant Air Conditioner

Attribute	Value	Comments
Systems Impacted	Cooling applications in humid environments	
Fuel Type	Electricity and Gas	
Relevant Annual Energy Consumption	1.07 Quads/yr	Consumption from all cooling applications (whole system); electric fuel sources; all building types in all climates; medium retrofit potential means moderate adoption by existing buildings
Technical Energy-Savings Potential	0.21 Quads/yr	Applied to relevant annual energy consumption by assuming energy usage reduction of 20%
Peak Demand Reduction	Medium	Depends on the humidity conditions of the climate during peak hours
Technical Maturity	Emerging	Basic product is commercialized in the U.S.; high-efficiency products are undergoing field testing
Retrofit Potential	Medium	Replacement for cooling plant of an HVAC system, or secondary addition to assist the primary cooling plant
Non-energy Benefits	<ul style="list-style-type: none"> - Improved Indoor Air Quality - Improved Comfort 	
Most Promising Applications	Commercial HVAC systems in humid climates with large latent loads and minimal sensible loads	
Next Steps for Technology	Improve the technology's efficiency and reliability, through measures such as: <ul style="list-style-type: none"> - Develop and evaluate noncorrosive liquid desiccants for alternative LDAC unit - Research and development of high-efficiency regenerating components - Improvement of the wetting and rewetting of the contact surfaces of the LDAC 	

Background

- Technology Description

Desiccants are materials that have a high affinity to water vapor, and can remove water from moist air when exposed to an airstream (AIL Research, Inc). A liquid desiccant air conditioner

(LDAC) uses a liquid desiccant to remove moisture from incoming supply air. This process both dries and cools the incoming air by reducing the incoming latent heat (Dieckmann, 2008). Industrial applications have used liquid desiccants (particularly lithium chloride) to dehumidify air since the 1930s (Lowenstein, 2008).

Liquid desiccant air conditioners use liquid desiccants to perform cooling, but operate as a cyclical process. It must also remove the water from the saturated liquid desiccant, in order to permit continual extraction of humidity, through a process called regeneration. Thus, a liquid desiccant air conditioner cycles between having a concentrated liquid desiccant solution and a weakened solution.

Liquid desiccants have two main components (Dieckmann, 2008):

- A conditioner that processes strong concentrations of liquid desiccant. It exposes the desiccant to the supply air, absorbs water vapor from the supply airstream, and feeds weakened concentrations of liquid desiccant to the regenerator.
- A regenerator that processes weak concentrations of liquid desiccant. It heats the desiccant, returns the water vapor to a return airstream, and cools the liquid desiccant before feeding strengthened concentrations of liquid desiccant back to the conditioner.

Many systems use a counterflow heat exchanger to gain some free regeneration of the desiccant, by exchanging heat between the desiccants streams entering and leaving the regenerator. Integrated systems can also use a downstream cooling coil to provide additional sensible cooling (Dieckmann, 2008). **Figure 3-9** below contains a picture of a complete assembly with a conditioner, regenerator, and counterflow heat exchanger.

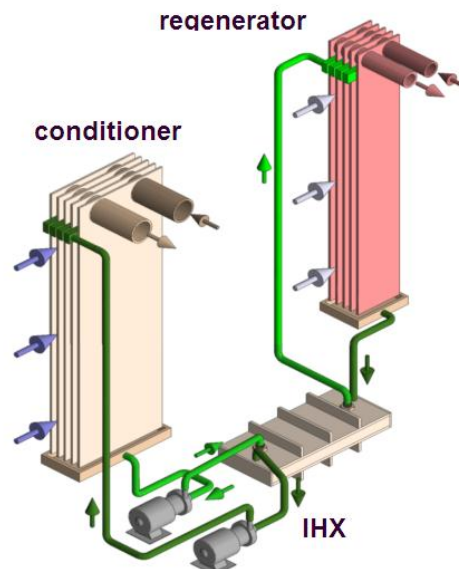

Figure 3-9: Design Configuration for a Liquid Desiccant Air Conditioner

Source: AIL Research, Inc.

An LDAC heats the regenerator's liquid desiccant solution using either low-grade waste heat, water heated through solar means, or gas heating and heat pumps. When used with a free source

of heating, LDACs can achieve higher efficiencies than conventional technologies. Solar-assisted LDACs also use a vat of liquid desiccant to store heat for cooling during darkened periods (Lowenstein, 2008).

Common liquid desiccants include glycols, halide salt solutions, and lithium chloride. Lithium bromide and mixtures of different salts are also strong candidates for use in liquid desiccant air conditioners (Lowenstein, 2008). Glycols and halide salt solutions possess many favorable properties for use in a liquid desiccant air conditioner, but also contain at least one unfavorable property:

- Glycols are volatile substances and must be properly contained
- Halide salts are corrosive and must be properly contained

The efficiency of the regenerator limits the efficiency of the overall system. Conventional systems use a simple one-effect regenerator. AIL Research has developed a 1 ½-effect regenerator that resembles a two-stage system (but only uses one boiler) (AIL Research). Further development may involve double-effect regeneration, triple-effect regeneration, or solar-thermal heating for regeneration.

- *Energy-Efficiency Advantages*

Liquid desiccant air conditioners can offer large energy savings in humid environments, especially when used in dedicated outdoor air systems (DOAS). Typical vapor-compression systems must deal with latent loads by overcooling the air to remove humidity and then reheating it to reach optimum interior temperatures. The LDAC significantly reduces the latent load experienced by a cooling system while consuming a fraction of the energy required by traditional systems.

An LDAC also enables additional energy savings by allowing building managers to alter their HVAC control strategies (Dieckmann, 2008). The following examples show some possible approaches:

- A conventional air-conditioner system can operate a higher evaporating temperature (and receive a boost in COP for doing so), while not sacrificing comfort
- Building managers may increase the indoor setpoint by 2° to 5° F, because humidification performance is no longer the main driver of interior temperature settings.

- *Peak-Demand Reduction and Other Non-Energy Benefits*

For technologies that can provide air-conditioning, we assumed that savings associated with peak demand would mirror savings associated with overall demand. We assumed that peak demand highly correlates with air-conditioning demand.

According to Lowenstein et al., liquid desiccant air conditioners can provide the following non-energy advantages over conventional systems (Lowenstein, 2006):

- Improved indoor air quality
- Improved comfort

- A more compact size

Advantix noted that in case studies, the liquid desiccant air conditioner eliminated humidity and condensation experienced under the previous system (Wende).

Energy-Savings Potential

- Potential Market and Retrofit Applications

Existing buildings with air-based delivery systems could incorporate LDAC units. LDAC units do not require any changes to existing delivery of cooling, but do require changes to the existing cooling plant. Adding additional features such as solar thermal collectors or waste heat streams would require additional labor and cost, and would increase the complexity of installing the LDAC system. The liquid desiccant air conditioner is also compatible with existing vapor-compression systems, when used as a supplemental DOAS system.

There are several limiting factors that will curb the adoption of liquid desiccant air conditioners. LDAC units reduce latent cooling loads without impacting sensible loads. Thus, LDAC units are only effective in climates with moderate to high humidity levels.

Based on these observations, our analysis assumes that this technology applies to the following building stock:

- Climate zones 4 and 5
- All building sizes
- All building types
- All cooling and heat pump applications
- Electric and Gas Applications
- Savings apply to full system energy use

- Energy Savings

- Based on an analysis of its potential impact on HVAC systems in the U.S., this technology would save no Quads of natural gas, and 0.214 Quads of electricity per year.

Liquid desiccant air conditioners offer significant energy savings only in hot-humid climates with large latent loads. ACEEE states that in such climates, liquid desiccant air conditioners could reduce HVAC costs 30% by replacing the strategy of over-cooling and reheating air (Sachs, 2009). Dieckmann et al. notes that a high-efficiency LDAC system (COP = 1.2) used as part of a larger HVAC system (as a DOAS) could achieve primary unit energy savings of 15% over conventional systems using the over-cooling and reheating strategy.

Building users can increase the efficiency of a liquid desiccant air-conditioner by using solar-heated water streams or waste heat streams to regenerate the desiccant. By using these strategies, building users could obtain primary unit energy savings of 20-25% (Dieckmann, 2008). A triple-effect regeneration system, if properly developed, could also achieve comparable savings.

Any buildings in hot-humid climates could potentially use liquid desiccant air conditioning to reduce latent loads on the primary cooling system. Based on an analysis of its potential impact to HVAC systems in the U.S., this technology would save 0.21 Quads of electricity per year.

Cost and Complexity

AIL Research, Inc. cited the cost of a first-generation LDAC unit (that provides 23 tons of latent cooling) as \$48,000. (Lowenstein, 2006) Dieckmann et al. noted that a liquid desiccant air conditioner has a cost premium of 65% compared to a comparable vapor-compression system with a DOAS.

AIL Research, Inc. also cited installed costs for solar-assisted LDAC units that possessed storage capabilities. These costs included costs for evacuated tube collectors and energy storage through desiccant in tanks. The costs included:

- A cost of \$187,000 for a 6000 cfm LDAC unit with a 3,000 sq. ft solar array and 12,000 lbs of liquid desiccant for storage. They calculated a payback period of 9.8 years compared to a conventional system using reheating.
- Similar LDAC systems for a 6000 cfm LDAC unit had similar paybacks (with a 2,000 sq ft array and 12,000 lb of storage, or with a 4,000 sq. ft array).

These installed costs assume an incremental cost of \$40 per sq. ft for evacuated tube collectors. AIL Research, Inc. noted that this cost is an optimistic estimate of the current cost of installation, and that these costs could range up to \$120 per sq. ft.

Technical Maturity and Perceived Barriers to Market Adoption

A basic liquid desiccant air conditioner (using a single-effect regenerator) is a commercial available technology but with low market penetration. It offers low technical energy-savings potential due to its low efficiency compared to conventional technology.

However, a more advanced liquid desiccant air conditioner (one that uses higher-effect regenerators) is not commercially available, and has a few product development issues to be resolved through short-term R&D activities. Additional field testing is also required to improve its market viability.

Lowenstein et al. noted that use of corrosive liquid desiccants would still pose a barrier in terms of convincing users to adopt the technology (Lowenstein, 2008). For development of solar-assisted LDAC systems, many sources noted that the high cost of evacuated tube collectors was a significant barrier to their adoption.

Next Steps for Technology Development

AIL Research, Inc. has performed field testing of several advanced liquid desiccant air conditioner units in Florida. Advantix systems also offer a line of single-effect liquid desiccant air conditioners.

Lowenstein et al. noted the following research need for LDAC, which will accelerate the development and adoption of LDAC units (Lowenstein, 2008):

- Identification of a Noncorrosive desiccant
- Development of an air-cooled unit to replace units using cooling towers
- Improvement of the wetting and rewetting of the contact surfaces of the LDAC
- Improvement of the COPs of current regenerators
- Application of advanced evaporative cooling techniques to LDACs
- Development of active management systems for managing desiccant quality and chemistry

In addition, stakeholders should perform additional field testing to provide more reliability and safety data for these units. For solar-assisted units, stakeholders should investigate cost-reduction measures and designs that can reduce the cost of solar thermal water heating. Utility stakeholders could also create incentive programs to encourage their use.

Table 3-7 presents the potential next steps for liquid desiccant air conditioning to gain greater market attention and acceptance.

Table 3-7: Recommended Next Steps for the Development of Liquid Desiccant Air Conditioners

Initiatives	Lead Organization(s)
Develop and evaluate noncorrosive liquid desiccants for alternative LDAC unit	DOE, Academic Institutions
Research and development of high-efficiency regenerating components	DOE, Academic Institutions
Research and develop improved processes for wetting and rewetting contact surfaces of the LDAC	DOE, Manufacturers
Develop active management systems for managing the desiccant in LDAC	DOE, Manufacturers
Create financial incentives to reduce first-costs through utility incentive programs	Utilities

Potential Combination with DEVap Technology

Liquid desiccant systems can be enhanced through the use of advanced evaporative cooling techniques. One technology that integrates these technologies is a DEVap A/C, which pairs a liquid desiccant air conditioner with an indirect evaporative cooling unit. This combination overcomes the limitations of both systems; a LDAC can provide dehumidification in hot and moist incoming air, while an indirect evaporative cooling unit can provide cooling (through humidification) in hot and dry incoming air. The DEVap system represents a complete cooling and dehumidifying system that can operate in both moist and dry conditions (Kozubal, et al. 2011). Current DEVap designs pursued by NREL may also offer improved containment of the liquid desiccant through the use of an innovative vapor-permeable membrane.

Thus, a fully-developed DEVap system may enhance the performance and safety offered by a conventional LDAC system. See Section 4.2 for more information about DEVap systems.

References

AIL Research, Inc. “LD Tutorial.” http://www.air.com/liquid_desiccant_tutorial.htm

Dieckmann, John, et al. “Liquid Desiccant Air Conditioners.” *Emerging Technologies – ASHRAE Journal*. October 2008.

“High Efficiency Liquid-Desiccant Regenerator for Air Conditioning and Industrial Drying.” Department of Energy Contract No. DE-FG36—03GO13170. Final Report. December 19, 2005.

Kozubal, et al. 2011. “Desiccant Enhanced Evaporative Air-Conditioning (DEVap): Evaluation of a New Concept in Ultra Efficient Air Conditioning.” NREL Report No. NREL/TP-5500-49722.

Lowenstein, Andrew and Miller, Jeffrey. “The Field Operation of a Thermally Driven Liquid-Desiccant Air Conditioner.” AIL Research, Inc.

Lowenstein, Andrew, et al. “A zero carryover liquid-desiccant air conditioner for solar applications.” AIL Research, Inc. and NREL. ASME International Solar Energy Conference, July 8-13, 2006. ISEC2006-99079.

Lowenstein, Andrew. “Review of Liquid Desiccant Technology for HVAC Applications.” *HVAC&R Research* Vol 14, Number 6. November 2008.

Sachs, H; Lin., W; and Lowenberger, A. “Emerging Energy-Saving HVAC Technologies and Practices for the Buildings Sector (2009).” December 2009. Report Number A092. American Council for an Energy-Efficient Economy (ACEEE).

Wende, Trevor. “Liquid Desiccant Air Conditioning.” Advantix Systems, Inc.

3.2.2 Magnetic Cooling Cycle

Brief Description	The magnetic cooling cycle provides cooling through magnetocaloric effect, a phenomenon where certain materials undergo temperature change when exposed to a changing magnetic field.	
Technical Energy-Savings Potential (Quads/year)	Market Readiness	DOE Priority
0.15 Quads/year	Low	Medium

Summary

Using the magnetic cooling cycle for air-conditioning applications is still in early-stage R&D. Paramagnetic materials change temperature when exposed to a changing magnetic field to provide cooling. Once fully developed, magnetic cooling systems could provide cooling without the conventional vapor-compression process, which is significantly reduce cooling energy consumption. However, the cooling capacities of existing prototypes today are much smaller than that of a typical commercial air-condition systems, and other uncertainties, most importantly the cost of the system, must be addressed before the technology will be ready for market adoption.

Table 3-8 summarizes magnetic cooling cycle.

Table 3-8: Summary of the Characteristics of Magnetic Cooling

Attribute	Value	Comments
Systems Impacted	All AC systems	Would replace vapor-compression system.
Fuel Type	Electricity	
Relevant Annual Energy Consumption	0.91 Quads/yr	50% of all AC energy consumption in the U.S.
Technical Energy-Savings Potential	0.15 Quads/yr	Assume 17% savings
Peak-Demand Reduction	Medium	
Technical Maturity	R&D (long-term)	Technology cannot be applied at a scale required to support commercial HVAC systems.
Retrofit Potential	Medium	Will require replacement of cooling plant.
Non-Energy Benefits	Reduced refrigerant use	
Most Promising Applications	Any types of commercial buildings, once the technology is fully developed.	
Next Steps for Technology	<ul style="list-style-type: none"> - Continue to develop an approach to increase the cooling capability of magnetic cooling cycle. - Continue to investigate lower-cost materials that could serve as alternatives to the current neodymium magnet. 	

Background

- Technology Description

Magnetic cooling is based on the magnetocaloric effect, a phenomenon in which a paramagnetic material exhibits reversible temperature change when exposed to a changing magnetic field. A magnetic cooling system applies a magnetic field to a paramagnetic material, which aligns randomly oriented electron spins in the paramagnetic material ($A \rightarrow B$ in **Figure 3-10**)—an exothermic process that raises the material's temperature. This heat is rejected from the material to its surroundings ($B \rightarrow C$). Upon removal of the magnetic field, the magnetic spins return to their randomized state—an endothermic process that cools the material ($C \rightarrow D$). The material then absorbs heat from the space to be cooled ($D \rightarrow A$). During this step, the paramagnetic material returns to its original state. The cycle then starts again.

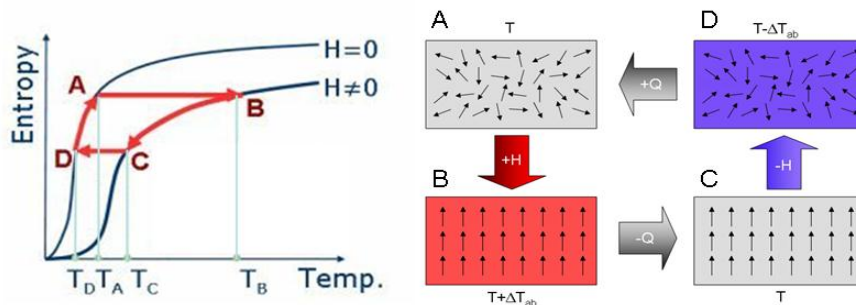

Figure 3-10: Magnetic Cooling Cycle

Source: Goetzler, et al. (2009)

Dickemann, et al. (2007) report that permanent magnets suitable for air-conditioning applications in commercial buildings can only produce a magnetic-field strength of up to 2 Teslas (T).¹¹ The investigators state that, because the maximum temperature change achievable by a 2 T magnetic field is 5 °C, some type of regenerative cycle is necessary for magnetic cooling cycle to be viable for space cooling in commercial buildings. One approach to accomplish this is the active magnetic regenerator cycle, a regenerative magnetic refrigeration cycle developed by Astronautics Corp of America. The active magnetic regenerator cycle uses a bed of magnetocaloric materials layered with materials having progressively higher Curie temperatures¹². By successively applying a magnetic field to the bed (and thus shifting the temperature gradient across the bed) and coordinating the flow of coolant, the temperature difference between the high and low sides is spanned regeneratively and heat can be absorbed from the cold source (the cooling load) and rejected to the higher temperature sink. Figure 3-11 presents the concept of the active magnetic regenerator cycle.

¹¹ The investigators report that, while stronger magnetic field could induce greater temperature change (e.g., magnetic field strength of 10 T could provide temperature drop of approximately 25 °C), obtaining magnetic fields of such strength would require significant parasitic energy consumption to power superconducting electromagnets. Powering such magnets would defeat the purpose of introducing magnetic cooling to replace the vapor-compression cycle.

¹² A temperature above which the material loses its magnetism

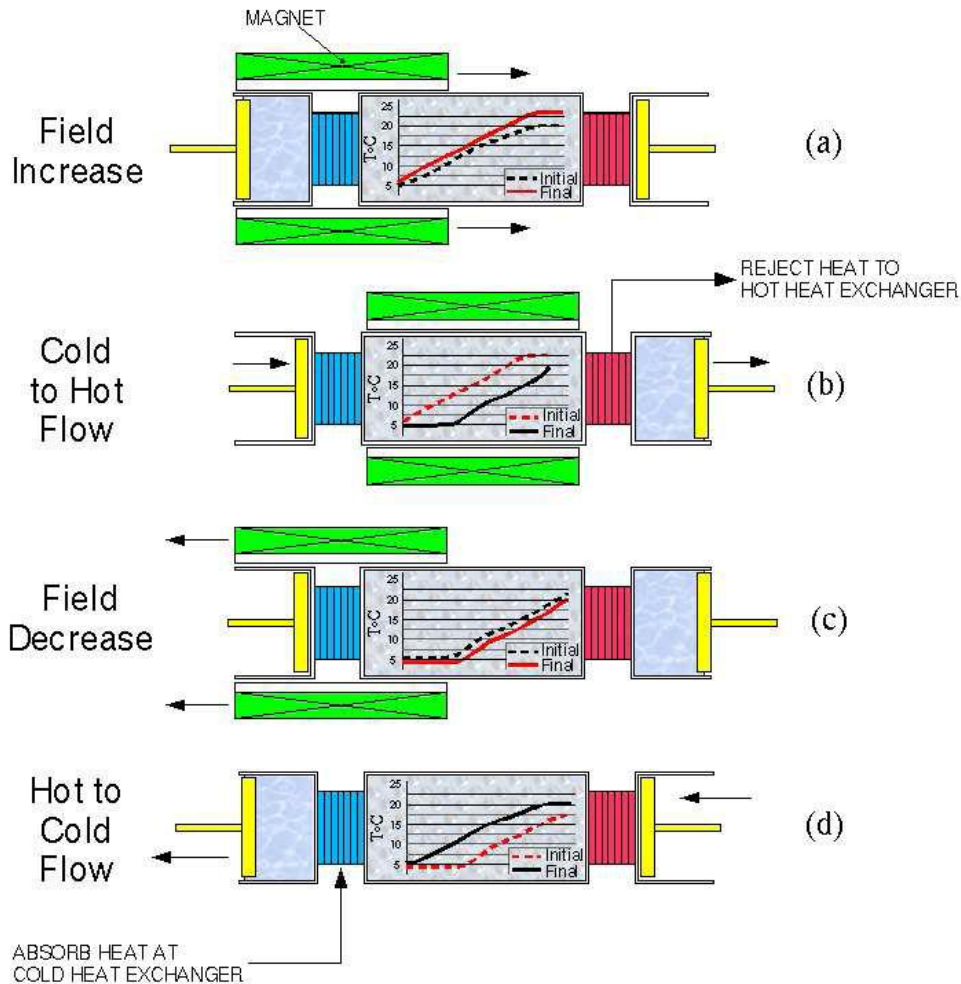

Figure 3-11: The Active Magnetic Regenerator Cycle

Source: Boeder, et al. (2006)

- *Energy-Efficiency Advantages*

The magnetic cooling cycle applies a cooling approach that is fundamentally different from the conventional vapor-compression cycle. The current aim of ongoing R&D is to improve the energy performance of the magnetic cooling system to exceed that of the vapor-compression system.

- *Peak-Demand Reduction and Other Non-Energy Benefits*

If applied to commercial air-conditioning systems, magnetic cooling cycle could provide modest reduction to peak demand through reduced energy consumption. Also, because the magnetic air-conditioning system relies on magnetocaloric effect to pump heat, it eliminates the use of chemical refrigerants.

Energy-Savings Potential

- *Potential Market and Retrofit Applications*

Once fully developed, the magnetic cooling cycle could replace vapor-compression cooling systems in chillers and rooftop AC units. The technology does not require any changes to the

way the cooled air is delivered to conditioned spaces; however, it does require total replacement of the cooling plant, which would require some additional effort if implemented as a retrofit solution. Otherwise, the technology would be applicable across all climate zones, and building types and sizes. Given these considerations, we estimate the relevant annual primary energy consumption for this technology to be 0.91 Quads.

- *Energy Savings*

Since the technology is still in an early R&D stage, the energy-savings performance of magnetic cooling cycle in commercial HVAC applicable is not yet known. According to Gschneidner, et al. (2008), the magnetic refrigeration system has the potential to reduce energy consumption by 20% over a conventional vapor-compression system. Some studies suggest even greater savings. For instance, Boeder, et al. (2006) finds through a computer simulation that a 23 SEER magnetic AC system is 28% more efficient when compared to an 18-SEER conventional vapor-compression system. This implies an overall efficiency improvement of nearly 50% compared to a baseline 11.2-EER unit.

Based on this limited information, we assume that magnetic cooling cycle, when replacing a conventional commercial air-conditioning system based on vapor-compression cycle, would improve the system efficiency by approximately 20%, resulting in a 17% reduction in annual energy consumption.

Cost and Complexity

Currently, there is no information on the economics of air-conditioning systems based on magnetic cooling cycle. However, Dieckmann, et al. (2007) and other publications note that the permanent magnet used to induce magnetocaloric effect accounts for a significant portion of the cost of the prototype systems developed so far.

Technical Maturity and Perceived Barriers to Market Adoption

Equipment using the magnetic cooling cycle is not commercially available. There are significant technical issues that will require long-term R&D efforts to resolve. According to research publications including Phan, et al. (2007), Dieckmann, et al. (2007), Liu, et al. (2009), and Gshneidner et al. (2008), current research efforts have focused on either: a) improving the cooling capacity of prototype systems using current magnetocaloric materials and permanent magnets; or b) identifying or developing new permanent magnets and magnetocaloric materials. Most of these efforts focus on near-room-temperature refrigeration applications.

A number of leading scientists and engineers from around the world have formed a working group on magnetic refrigeration in the IIR (International Institute for Refrigeration) to promote magnetic cooling as a viable, energy-efficient and environmentally friendly cooling technology. Leading RD&D entities include the Center for Neutron Research [Liu, et al. (2009)] at the National Institute of Standards and Technology (NIST), University of Maryland and Iowa State University. Astronautics Corporation of America is another major player in the RD&D of magnetic air-conditioning-system, and has designed, constructed and tested a subscale engineering prototype of a magnetic air-conditioning system in collaboration with Ames National Laboratory [Boeder, et al. (2006)].

A potentially significant barrier to the market adoption of magnetic-cooling technology is the volatile nature of the global market for rare earth metals. Gschneider, et al. (2008) notes that the cost of neodymium, a part of neodymium permanent magnet that will likely be used for residential and small-commercial applications, rose by a factor of 3.5 through a two-year period beginning in January 2005. This trend appears to have only intensified since, as Shen (2011) reports that the price of neodymium has risen by 420% over a 12-month period beginning in July 2010. Political factors (e.g. trade embargo by China, which accounts for 90% of the world’s supply of rare earth metals) are undeniably affecting the market stability, but perhaps a more important factor is the increased demand for neodymium from other sectors. Gorman (2009) and Shen (2011) both note that increased demand of neodymium magnets for hybrid vehicles (as a part of electric motors) and wind turbines (as a part of generators) is causing the shortage of neodymium supply worldwide.

Next Steps for Technology Development

Table 3-9 presents the potential next steps for the magnetic cooling cycle to gain greater market attention and acceptance.

Table 3-9: Recommended Next Steps for the Development of Magnetic Cooling Cycle

Initiatives	Lead Organization(s)
Continue to develop an approach to increase the cooling capability of magnetic cooling cycle.	DOE
Continue to investigate lower-cost materials that could serve as alternatives to neodymium magnet.	DOE

References

Boeder, A., and Zimm, C., 2006. “Magnetic Refrigeration Technology for High Efficiency Air Conditioning.” Report prepared by Astronautics Corporation of America for the U.S. Department of Energy. December.

Chubu Electric, 2006. “Development of Room Temperature Magnetic Refrigeration System - World leading performance a big step forward in achieving practical systems –“. Press Release. November 7. Retrieved July 6, 2011 from http://www.chuden.co.jp/english/corporate/press2006/1107_1.html.

Dieckmann, J., Roth, K., and Brodrick, J., 2007. “Emerging Technologies – Magnetic Refrigeration.” ASHRAE Journal. pp. 74-76. August.

Goetzler, W., Goffri, S., Jasinski, S., Legett, R., Lisle, H., Marantan, A., Millard, M., Pinault, D., Westphalen, D., and Zogg, R., 2009. “Energy Savings Potential and RD&D Opportunities for Commercial Refrigeration.” Report prepared by Navigant Consulting, Inc. for the U.S. Department of Energy Building Technologies Program. September.

Gorman, S., 2009. “As hybrid cars gobble rare metals, shortage looms”. Reuter. Retrieved July 7, 2011 from <http://www.reuters.com/article/2009/08/31/us-mining-toyota-idUSTRE57U02B20090831>.

Gschneider, K. A., and Pecharsky, V. K., 2008. "Thirty years of near room temperature magnetic cooling: Where we are today and future prospects." *International Journal of Refrigeration*. Vol. 31, pp. 945-961. January 25.

Liu, D., Yue, M., Zhang, J., McQueen, T.M., Lynn, J., Wang, X., Chen, Y., Li, J., Cava, R.J., Liu, X., Altounian, Z., and Huang, Q., 2009. "Origin and tuning of the magnetocaloric effect for the magnetic refrigerant $\text{Mn}_{1.1}\text{Fe}_{0.9}(\text{P}_{0.80}\text{Ge}_{0.20})$." January.

Shen, J., 2011. "Pressure to be lifted on rare earth element pricing, says Information Network ". Digitimes. Retrieved July 7, 2011 from <http://www.digitimes.com/news/a20110707PR201.html>.

3.2.3 Solar Enhanced Cooling System

Brief Description	Solar enhanced cooling systems generate heated water (using solar radiation) that drives thermally-activated cooling systems such as absorption cooling or liquid desiccants. The solar component does not provide cooling, but assists high-efficiency technologies by providing a free source of medium-grade heat. By adding a solar thermal component, thermally-driven cooling systems can effectively compete with conventional vapor-compression systems.	
Technical Energy-Savings Potential (Quads/year)	Market Readiness	DOE Priority
0.05 Quads/year	Medium	Medium

Summary

Solar enhanced cooling systems are thermally-activated cooling systems paired with solar thermal water heating systems. By procuring a free, sustainable source of medium-grade heating, thermally-activated cooling systems can achieve higher efficiencies than comparable vapor-compression systems. Solar thermal collectors (either flat-plate or evacuated-tube systems) can supply hot water with temperatures up to 330° F, enough to run a double-effect absorption chiller or a liquid desiccant air conditioner.

Solar enhanced cooling systems (as a whole) could be a direct replacement for vapor-compression cooling and heating systems; the solar collector component could be retrofit to existing thermally-activated systems. The application of this system depends on availability of rooftop or land area to install the large solar collector array. When combined with a high-efficiency technology, a solar enhanced cooling system could save offer 30% savings over conventional systems (and 10% savings over a non-solar enhanced system). Solar thermal collector systems are commercially available, but the high cost of the technology is the main barrier to additional market adoption. Significant cost-reduction efforts and incentive programs are necessary to encourage the wide-scale adoption of these systems.

Table 3-10 summarizes the characteristics, potential energy savings, and research status of this technology.

Table 3-10: Summary of the Characteristics of Solar Enhanced Cooling

Attribute	Value	Comments
Systems Impacted	Cooling applications for large buildings	
Fuel Type	Electricity and Gas	
Relevant Annual Energy Consumption	0.11 Quads/yr	Consumption from all cooling applications (whole system); gas and electric fuel sources; all building types in all climates; low retrofit potential means low adoption by existing buildings
Technical Energy-Savings Potential	0.05 Quads/yr	Applied to relevant annual energy consumption by increasing system efficiency by 90%
Peak Demand Reduction	Medium	Peak demand savings for this technology follow the air-conditioning savings offered
Technical Maturity	Emerging	Product is offered commercially; initial products are being field-tested
Retrofit Potential	Medium/Low	Dependent on space availability in the area (on the roof or on the ground) and viability of rooftop installation
Non-energy Benefits	Enables primary cooling technologies with non-energy benefits, such as absorption chillers and liquid desiccant air conditioners	
Most Promising Applications	<ul style="list-style-type: none"> - Commercial buildings with large and viable rooftop installation areas in sunny climates. - Commercial buildings using gas-powered heating to drive thermally-activated cooling. 	
Next Steps for Technology	Perform additional development to improve the technology, such as: <ul style="list-style-type: none"> - Investigate cost-reduction measures for evacuated-tubes - Research and development of alternative designs to replace evacuated tube design Also: <ul style="list-style-type: none"> - Create financial incentives to reduce first-costs through utility incentive programs 	

Background

- Technology Description

Many alternative air-conditioning cycles, such as absorption cycles or liquid desiccant regeneration cycles, use thermal heat sources to manipulate working fluids. Thermally-driven conditioning systems require a source of heat to run; most typical systems use a gas-fired heat source with COPs smaller than 1.

Thermally-driven conditioning systems (absorption chillers, liquid desiccant air-conditioners) may leverage waste heat or solar-heated water to run much more efficiently. A cheap source of low- or medium-grade heat can significantly boost the efficiency associated with these systems.

When hot water supplies are used, the efficiency of a heat-driven system increases as the supply hot-water temperature increases. Double-effect chillers require supply hot-water temperatures around 330° F to operate efficiently (ASME). Liquid desiccant air-conditioners can regenerate liquid desiccant using supply hot-water temperatures from 140° F to 210° F (Lowenstein).

Solar thermal collectors are one method for heating water to high temperatures. A roof-integrated solar-driven cooling system uses fixed rooftop reflectors to concentrate sunlight onto a water stream; the heated water is then delivered to the thermally-driven cooling system to drive efficient operation. The addition of the rooftop solar heating system allows the system to reach much higher efficiencies than are achieved through conventional gas-heating techniques. The additional gains in efficiency can make thermally-driven technologies much more competitive with current vapor-compression systems (ASME).

There are several designs of solar thermal collector systems. Two types of available collectors are flat-plate collectors and evacuated-tube collectors (Lowenstein).

The evacuated-tube solar thermal collector systems (such as the Power Roof) are composed of:

- Fixed primary reflectors that are “simply curved” (not parabolic) and fixed to the roof
- A cylindrical receiver made of evacuated tubes (glass exterior tube, stainless steel interior tube), that hangs above the primary reflectors and tracks the sun’s movements
- A secondary reflector in the evacuated space to assure that the light is concentrated onto the interior tube

Figure 3-12 below shows a picture of an evacuated-tube system in a typical configuration.

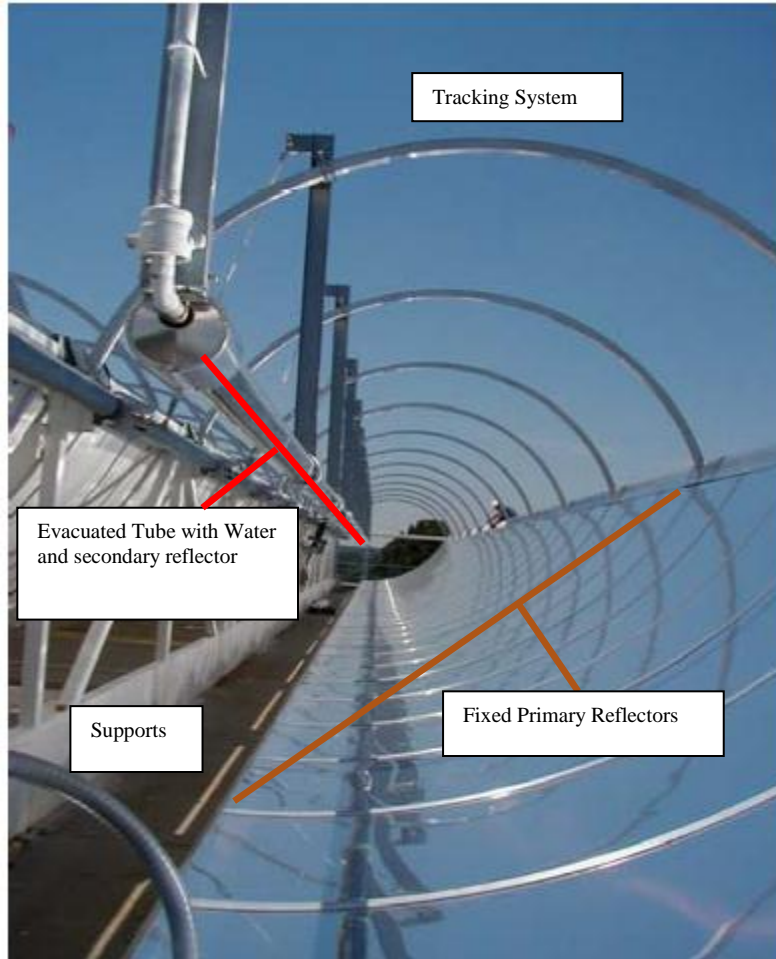

Figure 3-12: A typical rooftop evacuated-tube solar thermal array

Source: ASME

- *Energy-Efficiency Advantages*

The efficiency of a thermally-driven cooling system depends on the efficiency of the thermal source being used. There are usually two different kinds of systems:

- Low-efficiency thermally-driven systems must generate their own heat, which decreases the efficiency of the overall system, making them less attractive than conventional vapor-compression systems.
- Thermally-driven cooling systems with access to a constant source of free heat are more energy-efficient than conventional vapor-compression systems.

A solar thermal collector system enables these advanced cooling systems to achieve high efficiencies without spending additional energy to generate a source of heat. A common source of high-temperature heat is natural gas; however, the combustion process has a maximum COP of 1. Reducing or eliminating the energy consumption associated with generating high-temperature heat directly increases the efficiency of these systems.

- *Peak-Demand Reduction and Other Non-Energy Benefits*

For technologies that can provide air-conditioning, we assumed that savings associated with peak demand would mirror savings associated with overall demand. We assumed that peak demand highly correlates with air-conditioning demand.

The addition of a solar-collector array may provide one non-energy advantage over a conventional gas-driven thermally-activated system:

- Improved indoor air quality

In addition, the use of a solar-collector array may enable the use of technologies such as absorption chillers or liquid desiccant air-conditioners, which provide the following non-energy advantages over conventional systems:

- Improved indoor air quality
- Improved comfort

Energy-Savings Potential

- *Potential Market and Retrofit Applications*

Solar enhanced cooling systems are a substitute for chiller-based cooling and heating systems. All full chiller-based system could potentially be used in all cooling applications that use central plant chillers for heating and cooling. This assumes that the building stock this technology applies to includes:

- All climate zones
- All building sizes
- All building types
- All cooling and heat pump applications
- Gas and Electric Applications
- Savings apply to full system energy use

For retrofits, buildings must have enough unshaded open space (rooftop area or adjacent land area) to accommodate the collectors and tubes.

- *Energy Savings*

Based on an analysis of its potential impact on HVAC systems in the U.S., this technology would save 0.001 Quads of natural gas, and 0.051 Quads of electricity per year.

Building users can increase the efficiency of a liquid desiccant air-conditioner by using solar-heated water streams to regenerate the desiccant. By using these strategies, building users could obtain primary energy savings of 20-25% (Dieckmann, 2008). This is an improvement of 10% over similar systems with no solar-heated thermal source.

Using solar-heated water streams with double-effect absorption chillers can significantly increase the efficiency of these systems, which have a COP of around 1.1.

Cost and Complexity

AIL Research cited estimated installed costs for both flat-plate collectors and evacuated-tube collectors. Researchers estimated the cost of an evacuated-tube collector system with a supply water temperature of 210° F as \$167,000, and they estimated the cost of a flat-plate collector system of 170° F as \$172,000. Both of these systems were designed to supplement a 6000 cfm liquid desiccant air conditioner. System costs appeared to vary significantly depending on the hot-water supply temperature. The combined system (liquid desiccant air conditioner, storage, and solar thermal collector) had payback periods ranging from 9 to 10 years (Lowenstein).

Figure 3-13 shows how the total cost of a solar thermal collector system can vary according to the desired water-supply output temperature.

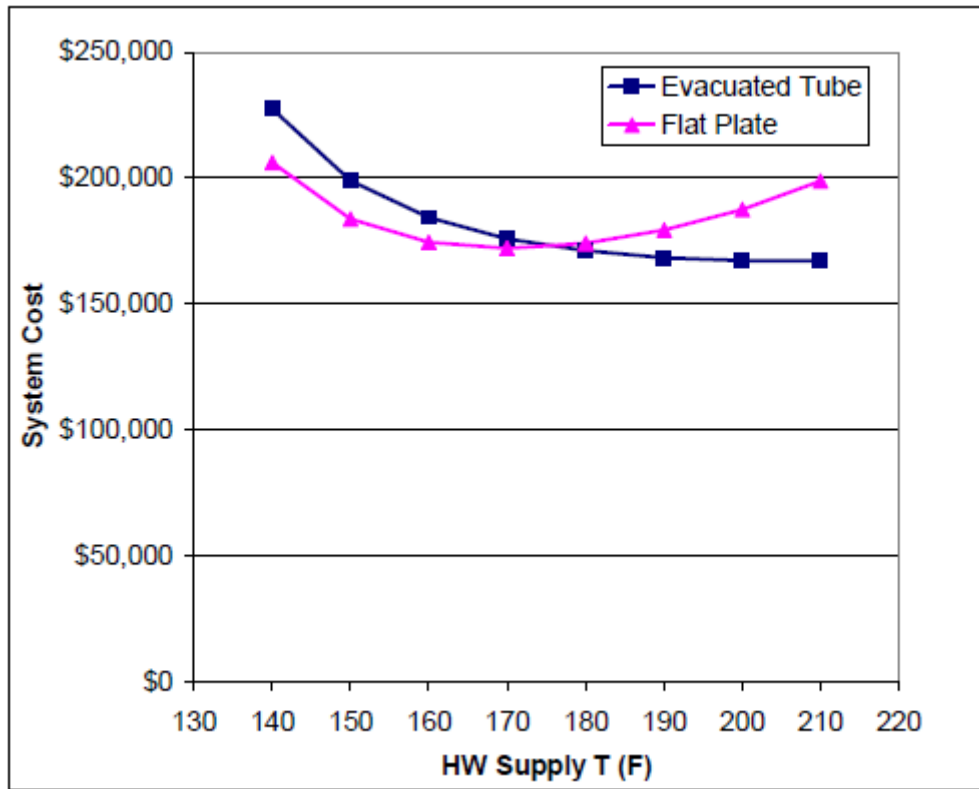

Figure 3-13: Solar Thermal Collector Cost as a Function of Hot-Water Supply Temperature

Source: AIL Research – Solar-Driven Liquid Desiccant

They modeled the cost of flat-plate tube collectors as \$25 per square foot and the cost of evacuated-tube collectors as \$40 per square foot. However, AIL Research noted that quoted prices ranged from \$40 to \$120 per square foot, and that \$40 per square foot for evacuated tube collectors was an optimistic assumption. For this reason, thermal collectors will represent the majority of the installed cost of a combined system (Lowenstein).

Technical Maturity and Perceived Barriers to Market Adoption

This is an emerging technology with limited availability in the US market today. It is offered by at least one manufacturer, Solargenix Energy (formerly Duke Solar Energy).

The largest barrier to solar collector systems is their cost. High costs of evacuated-tube collector tubes make the technology prohibitively expensive to deploy. However, the product costs may fall as the U.S. market becomes more mature (Lowenstein).

Two competing demands can limit the efficiency of the overall solar thermal system:

- The efficiency of the collector system decreases as the supply hot-water increases in temperature, for both flat-plate and evacuate-tube solar thermal collectors (Lowenstein).
- The efficiency of thermally-driven systems often increases as supply hot-water increases.

The efficiency challenge presented by these two competing trends is also a barrier to implementation of these systems.

Next Steps for Technology Development

In 2004, Solargenix Energy (formerly Solar Cooling, LLC) performed case studies of their roof-integrated solar cooling and heating system (ASME):

- one system used solar thermal collectors that powered double effect absorption chillers;
- a second system used solar thermal collectors that powered a liquid desiccant air conditioner

Solarsa International Ltd. Co also commercialized a solar thermal-assisted cooling system in 2007, called the “Energy Independence System.” It combines solar thermal collectors with an absorption chiller. Santa Clara University’s solar decathlon team integrated a prototype system into their residence. The system is targeted at small commercial buildings, such as restaurants (Solarsa, 2007).

Next steps for advancing this technology include:

- Additional demonstrations, including long-term assessment of energy savings
- Investigate cost-reduction measures for evacuated tubes
- Research and development of alternative designs to replace evacuated tube design

Table 3-11 presents the potential next steps for solar enhanced cooling to gain greater market attention and acceptance.

Table 3-11: Recommended Next Steps for the Development of Solar Enhanced Cooling Systems

Initiatives	Lead Organization(s)
Investigate cost-reduction measures for evacuated-tubes	Manufacturers
Research and development of increased heating efficiency for evacuated-tube designs	DOE, Manufacturers
Research and development of alternative designs to replace evacuated tube design	DOE, Academic Institutions
Run long-term field studies of prototypical systems on commercial buildings	DOE, Manufacturers
Create financial incentives to reduce first-costs through utility incentive programs	Utilities

References

ASME. Gee, Randy et al. “Operation and Preliminary Performance of the Duke Solar Power Roof: A Roof-Integrated Solar Cooling and Heating System.” Duke Solar Energy, LLC. ASME.

Dieckmann, John, et al. “Liquid Desiccant Air Conditioners.” Emerging Technologies – ASHRAE Journal. October 2008.

Gee, Randy. “Solar Powering of High Efficiency Absorption Chiller.” Final Report. Solar Cooling, LLC. Department of Energy. November 2004. DE-FC36-96GO10105M002.

Lowenstein, Andrew and Miller, Jeffery. “The Field Operation of a Thermally Driven Liquid-Desiccant Air Conditioner.” AIL Research, Inc.

Solarsa. “World’s first pre-assembled solar cooling unit unveiled.” September 17, 2007. Press Release. Solarsa International Ltd. Co. <http://scusolar.org/pdfs/SolarsaPressRelease.pdf>

Santa Clara University, Solar Decathlon. “Solar thermal panels and absorption chiller” <http://www.scusolar.org/technology.thermal>

Sakraida, Vincent. “Basics for Absorption Chillers.” March, 1, 2009. http://www.esmagazine.com/Articles/Feature_Article/BNP_GUID_9-5-2006_A_1000000000000539128

3.2.4 Solar Ventilation Preheating

Brief Description	Solar ventilation preheating systems use transpired collection panels to absorb solar radiation and transfer heat to ventilation air. This process offsets the use of gas or electricity to raise the ventilation air temperature to suitable building conditions during the heating season.	
Technical Energy-Savings Potential (Quads/year)	Market Readiness	DOE Priority
0.11 Quads/year	High	Medium

Summary

Solar ventilation preheating systems consist of a transpired panel and duct system which preheats ventilation air entering the building. Wall or roof mounted, dark colored or glazed panels absorb solar radiation, and pass the thermal energy to ventilation air the panels through tiny holes. A duct with a blower connects the panels to the existing building HVAC system and delivers ventilation air up to 40 °F above ambient, reducing or eliminating the need for conventional ventilation air preheating. The system provides cost effective, low-energy ventilation heating for buildings having sizable outdoor air requirements, long heating seasons, high energy costs, and available solar resources. If the building is a good candidate for this technology, the payback is typically less than 7 years for retrofit and less than 3 years for new construction projects. Barriers to this technology include aesthetics, difficulties in modeling performance, and lack of public awareness of the benefits and limitations of solar ventilation. Building a database of successful projects, improving modeling software, and public demonstrations of the technology should increase its market acceptance.

Table 3-12 presents a summary overview of solar ventilation preheating for commercial buildings.

Table 3-12: Summary of the Characteristics of Solar Ventilation Preheating

Attribute	Value	Comments
Systems Impacted	Ventilation Systems	
Fuel Type	Electricity and Gas	
Relevant Annual Energy Consumption	0.99 Quads/year	
Technology Energy-Savings Potential	0.11 Quads/year	
Peak Demand Reduction	Low	Unless replacing resistance OA heating
Estimated Payback	3-8 years	Depends on building orientation, ventilation requirements, and ambient temperatures
Technical Maturity	Comm. Available	
Retrofit Potential	Medium	Not all buildings will qualify
Non-energy Benefits	Passive Solar System	Low GWP, renewable heating
Most Promising Applications	Buildings with: <ul style="list-style-type: none"> - Sizable OA ventilation requirements - Long heating seasons - High cost of conventional heating energy - Large Southern facing wall or rooftop space without excess shading 	
Next Steps for Technology	<ul style="list-style-type: none"> - Streamline the estimation, design, and installation processes for various building types - Create a database of successful projects and best practices - Offer incentive programs to building operators 	

Background

- Technology Description

Commercial buildings require a considerable amount of ventilation using outdoor air (OA) to maintain occupant health and productivity. During heating season, the incoming OA is much colder than the conditioned space and must be heated to indoor conditions. Up to 15% of the total seasonal heating energy is consumed heating ventilation air. Solar ventilation preheating is a low-energy mechanism to raise the temperature of incoming OA using the sun as the primary energy source. Ventilation air that would normally be heated by gas or electricity is now heated (up to 40 °F temperature rise) by the sun. This largely reduces the energy needed to precondition OA in HVAC systems of commercial buildings.

The transpired or perforated panels are the heart of the solar preheating system. Each panel is either glazed or painted a dark color to absorb as much energy from sunlight as possible. Constructed from metal or plastic, the panels have small openings (around 1-3 mm) spread across their surface to facilitate airflow as seen in **Figure 3-14** below. The panels, warmed by solar radiation, transfer thermal energy to the OA as it passes through the small openings in the

panels. The heated OA is then ducted into the building by a combination of existing HVAC equipment, auxiliary fans, and the natural buoyancy of warm air. **Figure 3-15** below illustrates the process.



Figure 3-14: Sample of Transpired Solar Collectors

Source: Atas (2011)

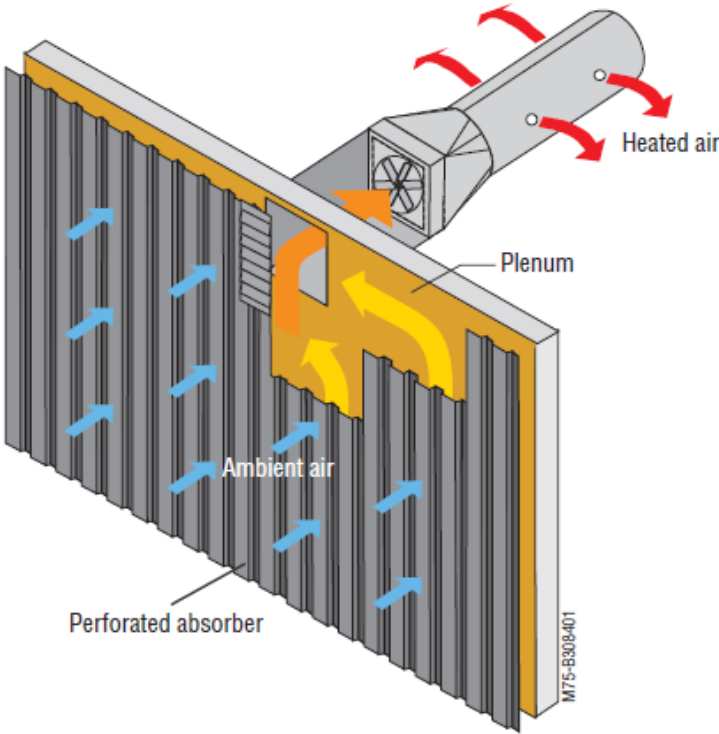

Figure 3-15: Typical Solar Ventilation System

Source: NREL (2006)

Transpired solar preheating systems can be wall mounted or roof mounted. Wall mounted systems, seen in **Figure 3-16**, consist of a facade of transpired panels offset by racking from the

Southern facing wall to create a warm-air plenum behind the panels. The plenum created by the building wall and the panel façade heats and transports the OA up the wall to the building's existing duct system to distribute the preheated ventilation air. The plenum created by wall mounted systems also acts as a thermal buffer to the building envelope, minimizing thermal losses associated with cold or windy conditions, leaky walls, and poor insulation.

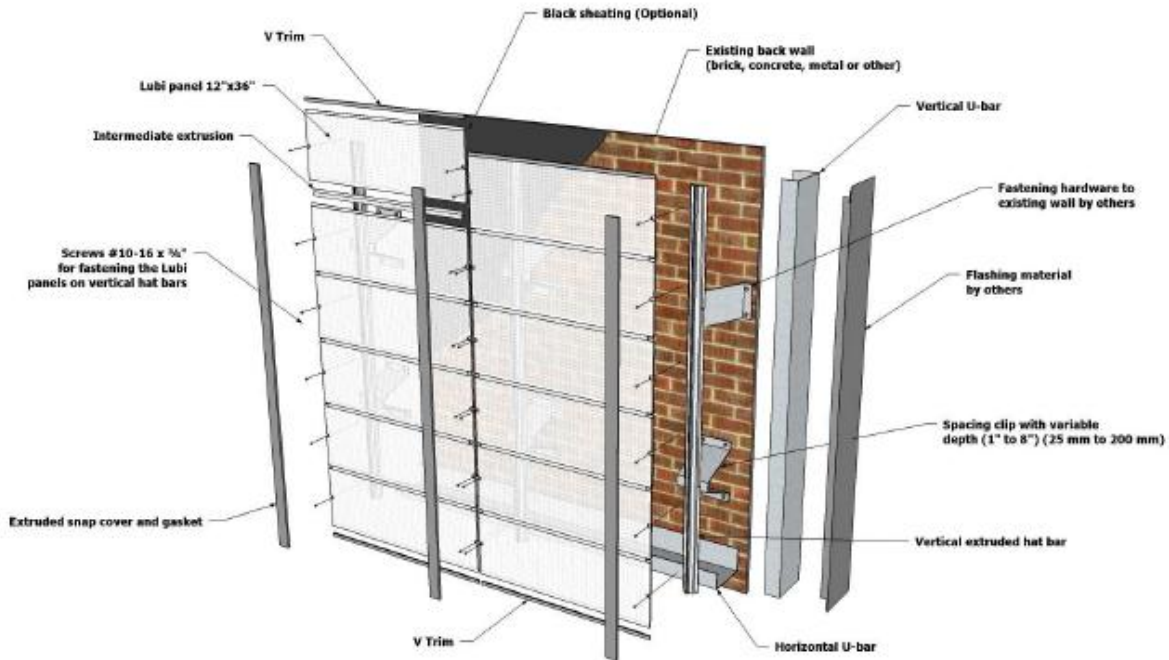

Figure 3-16: Wall Mounted Transpired Solar Collectors

Source: Enerconcept (2010)

Roof mounted systems, seen in **Figure 3-17**, consist of a series of modular collectors each having a transpired panel backed by a curved metal sheet. The OA flows across the solar-heated panel, absorbs energy, and is ducted into the existing HVAC system. This configuration can be placed wherever there is the available sunlight and is not limited by the wall's orientation. Both wall mounted and roof mounted systems can connect to existing HVAC equipment and can feature bypass dampers to isolate the solar preheating system during non-heating months.

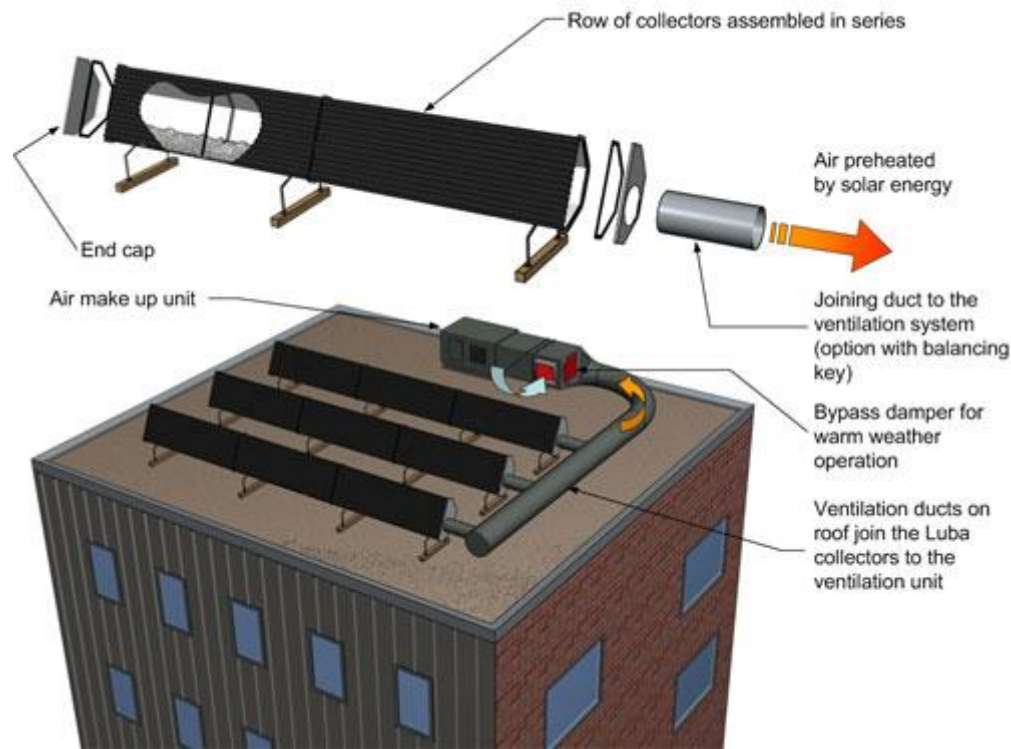

Figure 3-17: Roof Mounted Transpired Solar Collectors

Source: Enerconcept (2010)

- *Energy-Efficiency Advantages*

Solar ventilation preheating is a low-energy heating system that is placed either on the roof or exterior walls of a building. The transpired panels come in a variety of dark shades or transparent glazes to architecturally blend with the building. Drawing air through the panels requires little additional fan power (in part, due to the natural buoyancy of warm air), and can often use existing HVAC fans. In cases where a separate auxiliary fan is needed, the fan could be powered and passively controlled by PV panels because the preheating would only occur during daytime hours.

- *Peak Demand Reduction and Other Non-Energy Benefits*

The potential for peak demand reduction is low due to the fact that this technology would be most applicable in Northern U.S. climates that primarily use natural gas for heating and ventilation preheating. In cases where ventilation preheating is done by resistance heat, there will be a demand decrease.

Energy-Savings Potential

- *Potential Market and Retrofit Applications*

Solar ventilation preheating replaces much or all of the energy required to preheat OA from conventional heating equipment with solar energy. The energy savings for this technology depend on the OA requirement, type of heating fuel and cost, building location, available wall or roof space, and site solar resource. Although it is difficult to predict energy savings without a full analysis of these parameters, attractive applications would have the following characteristics:

- Sizable OA ventilation requirements
- Long heating seasons
- High cost of conventional heating energy
- Large Southern facing wall or rooftop space without excessive shading

Both new construction and existing buildings that meet the above criteria can benefit from this technology. For applicable locations, 1 sq.ft. of collector area can heat 4-10 cfm. Because not all buildings will meet the above conditions, solar ventilation preheating has a medium retrofit potential.

- *Energy Savings*

Based on an analysis of its potential impact on HVAC systems in the U.S., this technology would save 0.11 Quads of source heating energy per year.

Walker (2011) stated that transpired solar preheating panels are 80% efficient resulting in a 12% heating energy savings.

SolarWall (2011) is the largest manufacturer of the systems. They have measured a 20-50% reduction in the total building heating costs for their customers using the solar preheating panels.

Federal Technology Alert (1998) estimated a 17% total heating system savings with panels that transfer 60-75% of the available solar energy.

Cost and Complexity

The costs associated with solar preheating systems depend on the site-specific conditions, as stated previously. These systems can connect to the existing HVAC system, but can require auxiliary components such as ducting, dampers, fans, sensors, etc. Both wall mounted and roof mounted systems could easily connect to rooftop HVAC systems and ductwork in many applications. Designing solar preheating in conjunction with HVAC equipment reduces the amount of ducting required to connect the systems. In new construction, installing a wall mounted system may eliminate the need for expensive building exterior facades, because it will be covered by the panels. Because of this, new construction projects need only an insulated and Southern facing wall.

National Renewable Energy Laboratory (1996) discussed the advantages of the technology and notes that the existing installations have payback periods less than 3 years for new construction, and 6-7 years for retrofit. Total building energy savings amount to \$1-3/ building sq.ft. yearly.

Atas (2010) is a manufacturer of the Inspire line of solar preheating panels. They state that the material costs are \$14-17 per sq.ft. for metal panels with a 3-8 year expected payback.

Federal Technology Alert (1998) stated that the SolarWall system has an installed cost of \$11 per sq.ft. for metal panels with a typical payback of less than 5 years.

Technical Maturity and Perceived Barriers to Market Adoption

Transpired solar collector systems are a commercially available technology with a number of manufacturers including Atas International, Enerconcept Technologies, and SolarWall. Market acceptance has been hampered due to the lack of awareness among building designers and the difficulty of quickly predicting savings. The technology has been used for over 20 years, and proven to work in applications where the conditions stated earlier are met. Poorly designed systems in the 1970s tarnished public perception for transpired collectors, but the current systems have a proven performance history (Federal Technology Alert, 1998).

Days with cloud cover or very low temperatures lower the heat output, so most installations would require a backup ventilation-air system. Buildings having heat recovery systems to heat ventilation air would not benefit from solar preheating. The metal panels can be painted a variety of colors, and may be visually unappealing to some building designers and owners/occupants. The most efficient transpired panel designs, dark black or heavily glazed, are often not aesthetically pleasing. For wall mounted systems, windows add to design complexity and drop system performance. Not only do windows reduce the available surface area, but the pressure differential caused by an irregular plenum (to avoid covering windows) increases fan consumption. Also, with wall mounted systems can present fire code issues for multi-story buildings, but these issues can be mitigated in some locations.

Next Steps for Technology Development

This solar heating technology is simple, proven, cost-effective and should see larger market acceptance in coming years. Large offices, warehouses, garages, hangars, and other commercial and industrial buildings can benefit from this technology if site-specific conditions permit installation. As building designers, occupants, and owners strive for increased renewable and building integrated technologies, solar ventilation heating may become more common, especially if introduced in the initial design stage.

Table 3-13 presents the potential next steps for solar ventilation preheating to gain greater market attention and acceptance.

Table 3-13: Recommended Next Steps for the Development of Solar Ventilation Preheating

Initiatives	Lead Organization(s)
Streamline the estimation, design, and installation processes for various building types	Manufacturers
Create a database of successful projects and best practices	DOE, Manufacturers
Offer incentive programs to lower the upfront cost of this technology to building operators	DOE, Utilities

References

Enerconcept Technologies Inc. 2010. “Wall or Roof-mounted Lubi Collector: Technical Specifications and Mounting Instructions.” Retrieved from <http://www.enerconcept.com/>.

Federal Energy Management Program. 1996. “Solar Ventilation Preheating.” U.S. Department of Energy. DOE/GO-10096-268.

Federal Technology Alert. 1998. “Transpired Collectors (Solar Preheaters for Outdoor Ventilation Air).” Federal Energy Management Program. U.S. Department of Energy. DOE/GO-10098-528.

Inspire by Atas. 2011. Atas International Inc. Retrieved from <http://www.atas.com/>.

National Renewable Energy Laboratory. 2006. “Solar Buildings – Transpired Air Collectors Ventilation Preheating.” U.S. Department of Energy. DOE/GO-102001-1288.

SolarWall. 2011. Conserval Engineering Inc. Retrieved from <http://solarwall.com/>.

Walker, Andrew. 2011. “An Overview of Solar Ventilation Air Heating.” Retrieved from <http://www.reedconstructiondata.com/>.

Walker, A. and Sprunt Crawley, A. 2010. “Transpired Solar Collector at NREL’s Waste Handling Facility Uses Solar Energy to Heat Ventilation Air.” Federal Energy Management Program. DOE/GO-102010-3096.

3.2.5 Thermoelectric Cooling System

Brief Description	Thermoelectric cooling systems create a cooling effect by applying voltages across specialized thermoelectric materials. This solid-state technology may become highly efficient once fully mature, but it requires additional long-term research to increase the performance of the current thermoelectric materials.	
Technical Energy-Savings Potential (Quads/year)	Market Readiness	DOE Priority
0.38 Quads/year	Low	Medium

Summary

Thermoelectric systems are solid-state systems that offer large efficiency gains through the use of thermoelectric materials. The Peltier effect describes the unique behavior of thermoelectric materials: placing a voltage across the material creates a temperature difference at the two opposite ends. Current thermoelectric systems (using commercialized thermoelectric materials) offer low-efficiencies, but development of better materials would enable the creation of high-efficiency thermoelectric systems.

Thermoelectric systems could be a direct replacement for vapor-compression cooling and heating systems, and could be integrated into all building types. Mature thermoelectric systems could offer 50% savings over conventional systems, provided that needed material developments occur (Goetzler, 2009). They also offer the advantages of a smaller, quieter system without any refrigerant emissions, but, at sizes greater than 50W, are more expensive than conventional technologies (Dieckmann, 2011). Currently, smaller low-efficiency refrigeration systems have been commercialized, but significant increases in the room-temperature efficiency of thermoelectric materials are needed to make this technology a viable solution in other applications.

Table 3-14 summarizes the characteristics, technical energy-savings potential, and research status of this technology.

Table 3-14: Summary of the Characteristics of Thermoelectric Cooling System

Attribute	Value	Comments
Systems Impacted	All cooling and heat pump applications	
Fuel Type	Electricity	
Relevant Annual Energy Consumption	1.13 Quads/yr	Consumption from all cooling and heat pump applications (whole system); electric fuel sources; all building types in all climates; medium retrofit potential means moderate adoption by existing buildings
Technical Energy-Savings Potential	0.38 Quads/yr	Applied to relevant annual energy consumption by increasing system efficiency by 50%
Peak Demand Reduction	Medium	Peak demand savings for this technology follow the air-conditioning savings offered
Technical Maturity	R&D (long-term)	Significant research needed to increase efficiency of materials
Retrofit Potential	Medium	Replacement for the cooling plant of an HVAC system
Non-energy Benefits	<ul style="list-style-type: none"> - No emissions (due to no refrigerant) - Quieter operation - Greater reliability (no moving parts) - Smaller equipment footprint 	
Most Promising Applications	Commercial buildings with smaller building loads	
Next Steps for Technology	Perform additional R&D to address fundamental issues, including: <ul style="list-style-type: none"> - Develop and test new mixtures and nano-scale structures to increase the ZT of thermoelectric materials at room temperature - Research and develop new optimized fabrication techniques for large-capacity thermoelectric modules - Research and develop new fabrication techniques for alternative materials used for thermoelectric 	

Background

- *Technology Description*

Thermoelectric systems are solid-state systems that convert electrical energy into thermal energy (Goetzler, 2009). Thermoelectric materials provide the system’s sole cooling source, producing temperature gradients in response to an electric current.

The physical phenomenon that describes the behavior of thermoelectric materials is the Peltier effect (Goetzler, 2009). When a voltage is placed across a thermoelectric material (often a semiconductor), the voltage drives a current flow that moves electrons from one side of the material to another. These high energy electrons transport heat through the material. The rate of heat transfer is proportional to the applied current (Brown, 2010). This creates a hot surface and

a cold surface on opposite ends of the conductor; this temperature difference drives the system's cooling effect.

A thermoelectric material can also create a voltage by heating the ends of the conductor, using the reverse of the Peltier effect (the Seebeck effect).

Thermoelectric systems consist of hundreds of elements that leverage this cooling. Thermoelectric elements consist of two thermoelectric semiconductors: one is an n-type conductor (contains negative charge carriers) and the other is a p-type conductor (contains positive charge carriers). They are connected electrically in series and thermally in parallel; other configurations are possible but are not as effective for moving heat (PNNL 2009). **Figure 3-18** shows both an individual element consisting of two semiconductors, and an array of elements that comprise an electric thermoelectric system.

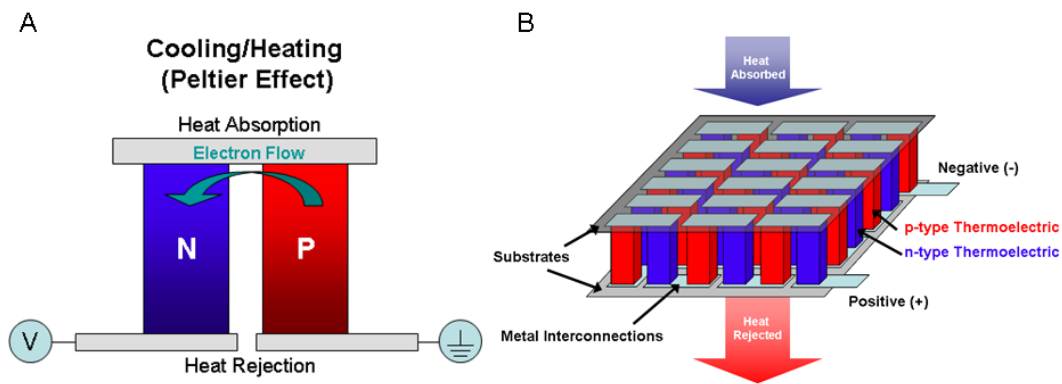

Figure 3-18: Thermoelectric heat engines

Source: Goetzler, 2009

The best thermoelectric materials are electrically conductive, thermally insulating, and have a high Seebeck coefficient (Brown, 2010). Scientists describe the effectiveness of a thermoelectric material using their 'ZT', a dimensionless grouping of their electrical and thermal properties. Materials with higher ZT produce cooling at higher efficiencies. Current thermoelectric systems use semiconductor materials with ZT's of 1.0; the best available materials are Bi₂Te₃-base superlattices and PbTe-based quantum dot superlattices (Brown, 2010) with ZT's of 2.5 and 2.0 respectively. **Figure 3-19** shows some of the measured ZT's for recently developed materials; it also demonstrates that ZT can significantly vary depending on the ambient temperature.

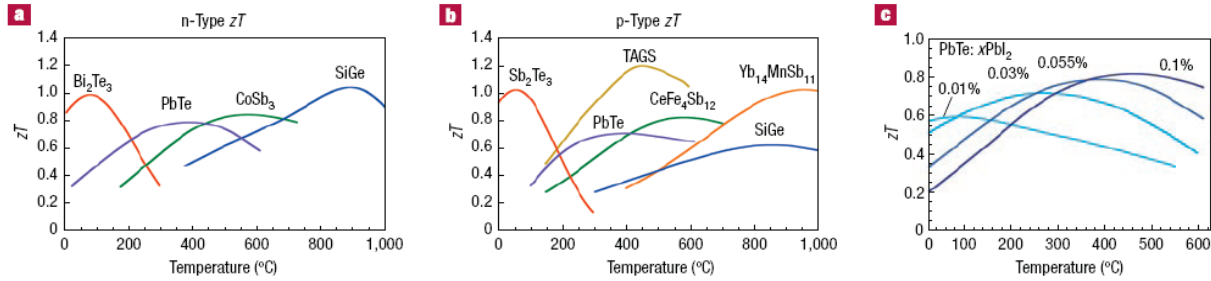

Figure 3-19: ZT of State-of-the-Art Materials

These charts include materials used or being developed (commercially or by NASA) for thermoelectric power generation. (a), p-type and (b), n-type. Most of these materials are complex alloys with dopants. (c)

Source: (Snyder 2008)

The graphs show that the peak ZT and the peak’s temperature are functions of the doping concentration. Snyder also noted that “as the dopant concentration in n-type PbTe increases (darker blue lines indicate higher doping) the ZT peak increases in temperature.” (Snyder 2008)

- *Energy-Efficiency Advantages*

Solid-state cooling systems do not rely on vapor compression to generate cooling, which can eliminate the system’s energy consumption associated with a compressor.

A thermoelectric system using a commercially-used thermoelectric material has a COP of 1 to 1.5 (10% to 15% of Carnot efficiency). PNNL suggests that the efficiency of these systems would double by using the best thermoelectric materials available (ZT of 2-2.5) (Brown, 2010). PNNL also notes that thermoelectric systems require materials with even higher ZT’s to be competitive with vapor-compression systems (ZT of 3 or higher) (Brown, 2010). **Table 3-15** summarizes the different efficiency levels (based on Carnot efficiency) found in thermoelectric and conventional equipment.

Table 3-15: Efficiency of Various Cooling Systems compared to Carnot

System	% Efficiency compared to Carnot
Current Thermoelectric Systems	15%
Max Thermoelectric (current materials)	30%
Current Compressors	45%
Potential Mature Thermoelectric (new materials)	60% ¹

¹: Based on estimates from Goetzler, et al. 2009

- *Peak-Demand Reduction and Other Non-Energy Benefits*

For technologies that can provide air-conditioning, we assumed that savings associated with peak demand would mirror savings associated with overall demand. We assumed that peak demand highly correlates with air-conditioning demand.

PNNL lists the following non-energy advantages that a mature thermoelectric system would have over traditional vapor-compressions systems (Brown, 2010):

- Greater reliability (no moving parts)
- Smaller equipment footprint
- Silent operation
- No emissions from refrigerants

Energy-Savings Potential

- Potential Market and Retrofit Applications

Thermoelectric cooling systems are a direct alternative to vapor-compression cooling and heating systems. New and existing buildings could use thermoelectric cooling in potentially all cooling applications as the primary cooling plant, or as a supplemental addition to conventional systems.

Based on these observations, our analysis assumes that this technology applies to the following building stock:

- All climate zones
- All building sizes
- All building types
- All cooling and heat pump applications
- Electric Applications
- Savings apply to full system energy use

- Energy Savings

Based on an analysis of its potential impact on HVAC systems in the U.S., this technology would save no Quads of natural gas, and 0.375 Quads of electricity per year.

Potential unit energy savings are entirely dependent on the improvements made to material properties. As room-temperature thermoelectric materials with higher efficiencies are produced, greater unit energy savings become possible. Current research has focused on raising the room-temperature efficiency of target materials so that they can match the efficiency of current vapor-compression systems. To reach this goal, materials must reach a ZT value of 3 at room temperature, much higher than the ZT value of 1 that current commercial materials possess. Current research projects have begun to approach this target efficiency (Dieckmann, 2011).

According to Navigant, researchers have claimed that fully-developed, high-efficiency thermoelectric cooling systems could surpass the efficiency of conventional cooling cycles by 50% (Goetzler, 2009).

Cost and Complexity

Regardless of efficiency concerns, thermoelectric systems are currently too expensive to produce for large applications above 50W of cooling (Dieckmann, 2011). According to Dieckmann et al.,

systems below this threshold use a small number of thermoelectric modules to meet the cooling demands. These systems require only a small number of modules, with limited integration.

Larger systems are more difficult, because thermoelectric modules are difficult to mass-produce and rely on semiconductor production techniques that haven't been perfected for thermoelectric systems (Bell). For example, thermocouple production requires production of electrode ends with low electrical and thermal resistances for installation in complex configurations. Improper production or installation of these components can have a significant effect on the system's overall ZT. Many newly developed materials are difficult to manipulate for production, and subject to degradation under tests. Finally, the high costs of rare materials can severely penalize currently commercialized processes that make inefficient use of materials.

These issues add significantly to the complexity (and manufacturing cost) of these systems. However, once production issues are solved, solid-state cooling systems will be smaller and easier to integrate into all manner of cooling systems.

Technical Maturity and Perceived Barriers to Market Adoption

A high-efficiency version of this technology is not commercially available, with a few significant technical issues that requires long-term R&D efforts before they are resolved. Small, low-efficiency systems have established the technical viability of thermoelectric systems; Marlow, Melcor, ADV-Engineering, Thermoelectric Cooling America, and Tellurex have released thermoelectric commercial products for spot heating and cooling. However, significant research is needed to develop materials capable of powering high-efficiency thermoelectric systems.

The low efficiency of thermoelectric systems compared to typical vapor-compression systems remains the main barrier to broad market adoption of thermoelectrics. Current materials do not offer enough efficiency, and further developments in material research are needed. There are several challenges to developing materials with higher ZT values (Goetzler, 2009):

- High ZT materials have a conflicting combination of physical properties, restricting the available development paths. Common materials tend have both high thermal conductivity and high electrical conductivity, but materials with low thermal conductivity and high electrical conductivity are ideal.
- High ZT materials require a specific type of material structure, restricting the availability of development paths

Bell noted that several factors have arrested the pace of research and commercialization of thermoelectric materials. They include (Bell):

- Validation of the properties of new materials can be difficult and error-prone.
- Thin-film materials can be highly difficult to mass produce, and often cannot be produced by the same laboratory techniques employed to test them.
- Shear stresses due to the expansion and compression of the thermoelectric materials in each module also causes large stresses on the system.

Next Steps for Technology Development

Several manufacturers have commercialized small, low-efficiency thermoelectric devices for refrigeration applications, including portable coolers, wine cabinets, mini-refrigerators, and water coolers. These applications use thermoelectric materials with ZT values of 1 (Goetzler, 2009). In these applications, the non-energy benefits of thermoelectric systems make them attractive, and the low-efficiency is generally not a concern. Manufacturers have used thermoelectric in these applications because the system meets the following needs (PNNL 2009):

- Silent and reliable operation
- Small cooling loads and small temperature differences
- Spot cooling
- Limited Space

A major development challenge will be to produce thermoelectric cooling systems that can reach beyond these niche markets. Development to both increase the size of these systems and increase efficiency is needed. For both goals, development of materials with higher ZT values is the most crucial step.

Thermoelectric systems are inefficient due to the high resistance and thermal conduction losses experienced by the thermoelectric materials during operation (a result of the lower ZT values of current materials). Researchers are currently investigating methods to reduce these losses in order to increase the efficiency of the materials. One method is to add quantum wells or quantum dots to materials using semiconductor fabrication techniques, which increases electrical conductivity but decreases thermal conductivity. Scientists have identified several materials that are able to use this method (Dieckmann, 2011). Hick and Dresselhouse have also demonstrated that significant gains in ZT can be made by using nanostructural engineering on the thermoelectric materials (Goetzler, 2009).

Table 3-16 presents the potential next steps for thermoelectric cooling cycles to gain greater market attention and acceptance.

Table 3-16: Recommended Next Steps for the Development of Thermoelectric Cooling Systems

Initiatives	Lead Organization(s)
Develop and test new mixtures and nano-scale structures to increase the ZT of thermoelectric materials at room temperature	DOE, Academic Institutions
Research and develop low-cost manufacturing practices for producing thermoelectric products	DOE, Manufacturers
Research and develop new optimized fabrication techniques for large-capacity thermoelectric modules	DOE , Manufacturers
Research and develop new fabrication techniques for alternative materials used for thermoelectric	DOE, Academic Institutions

Sources: CRE1

References

Bell, L. “Accelerating the Commercialization of Promising New Thermoelectric Materials.” BSST LLC, Irwindale, California USA. ASM International.

Brown, DR. et al. “The Prospects of Alternatives to Vapor Compression Technology for Space Cooling and Food Refrigeration Applications.” PNNL-19259. PNNL. March 2010. Prepared for the U.S. DOE under contract DE-AC05-76RL01830.

Dieckmann, John et al. “Solid-State Cooling, Part 1.” Emerging Technologies – ASHRAE Journal. March 2011. ASHRAE.

Goetzler, W. et al. “Energy Savings Potential and R&D Opportunities for Commercial Refrigeration.” Final Report. Navigant Consulting, Inc. September 23, 2009.

Snyder, G.J., and Toberer, E.S. “Complex Thermoelectric Materials”, *Nature Materials*, **7**, 105 (2008).

3.2.6 Thermotunneling Cooling System

Brief Description	Thermotunneling cooling systems are driven by an advanced form of thermoelectric cooling. The technology drives electron transfer across a vacuum gap to obtain cooling and heating. This solid-state technology may become highly efficient but requires additional long-term research to solve a number of technical concerns.	
Technical Energy-Savings Potential (Quads/year)	Market Readiness	DOE Priority
0.10 Quads/year	Low	Medium

Summary

Thermotunneling cooling is a solid-state system similar to thermoelectric systems but less mature and more complex. Thermotunneling systems rely on the transmission of electrons across a nanometer-length vacuum gap (driven by an applied voltage) to create a temperature difference between the two surfaces. Thermotunneling systems also make use of low work-function materials to further increase the efficiency of the system. The presence of the vacuum gap eliminates the backwards heat transfer issues that restrict the efficiency of conventional thermoelectric systems.

Thermotunneling system could be a direct replacement for vapor-compression cooling and heating systems, and could be integrated into all building types. Mature thermotunneling systems could offer efficiency gains of 35% over conventional vapor-compression technology, and also offer the advantages of a smaller, quieter system without any refrigerant emissions. GE projected that costs for mature thermotunneling systems could be competitive with conventional systems.

Significant long-term research and development of these systems is needed to understand the fundamental behavior of the system and overcome design and manufacturing challenges. While private companies have obtained patents and researched these systems, no prospective systems have emerged.

Table 3-17 summarizes the characteristics, technical energy-savings potential, and research status of this technology.

Table 3-17: Summary of the Characteristics of Thermotunneling Cooling System

Attribute	Value	Comments
Systems Impacted	All cooling and heat pump applications	
Fuel Type	Electricity	
Relevant Annual Energy Consumption	1.13 Quads/yr	Consumption from all cooling and heat pump applications (whole system); electric fuel sources; all building types in all climates; medium retrofit potential means moderate adoption by existing buildings
Technical Energy-Savings Potential	0.10 Quads/yr	Applied to relevant annual energy consumption by increasing system efficiency by 10%
Peak Demand Reduction	Medium	Peak demand savings for this technology follow the air-conditioning savings offered
Technical Maturity	R&D (long-term)	Significant research needed to address fundamental technical issues
Retrofit Potential	Medium	Replacement for the cooling plant of an HVAC system
Non-energy Benefits	<ul style="list-style-type: none"> - No emissions (due to no refrigerant) - Quieter operation - Greater reliability (no moving parts) - More flexibility in the system design 	
Most Promising Applications	Commercial buildings with smaller building loads	
Next Steps for Technology	Perform additional R&D to address fundamental issues, including: <ul style="list-style-type: none"> - Research and develop designs for modules employing nanometer-scale vacuum gaps over larger areas than currently demonstrated - Research and development of viable low-work function materials for use in thermotunneling systems - Research and develop new optimized fabrication techniques for thermotunneling systems using alternative materials 	

Background

- Technology Description

Thermotunneling cooling is a solid-state cooling technology. The technology, like other thermoelectric systems, is enabled by the Peltier effect. In certain materials, the transfer of high energy electrons from one surface to another results in heating and cooling of these surfaces. Thermotunneling cooling is a member of a family of technologies based on this principle. In thermoelectric systems, the transfer of electrons between the hot and cold surface occurs through quantum tunneling (or field emission).

The scientific principle behind thermotunneling states that electron transfer between two surfaces can require less energy than anticipated when the two surfaces are only nanometers apart, because of a quantum process called field emission. In practice, by applying a voltage across the two surfaces (separated by a vacuum), the system creates a constant stream of high-energy electrons in one direction, with less energy than previously required. This electron stream maintains the temperature gradient between the two plates (Brown, 2010).

Thermotunneling systems differ from both thermoelectric systems and thermoionic systems. Thermoelectric systems rely on conduction of electrons through thermoelectric systems. The transfer of electrons is driven by a voltage across the material. The thermoelectric system's overall efficiency is significantly reduced by backwards heat transfer between the hot and cold surface. A thermoionic systems do not rely on diffusion to transfer electrons, but rely on ballistic electron transport (discharge of electrons from the surface of a material). These systems rely on bands of metals and semi-conductors to achieve temperature differentials, but still experience some backwards heat transfer across the materials. Thermotunneling uses quantum tunneling of electrons to transfer heat between the two surfaces. Most importantly, thermotunneling systems can insert a vacuum between the two surfaces, removing a major source of inefficiency (Brown, 2010).

Thermotunneling cooling systems consist of three main elements:

- An electron emitter plate that emits high-energy electrons, cools down as a result, and provides a low-temperature surface
- An electron collector plate that absorbs high-energy electrons, heats up as a result, and provides a high-temperature surface
- A thin vacuum layer that lies between the plates and prevents backwards heat transfer

The system must use low-work function materials to obtain the advantages of a thermotunneling system (Brown, 2010). These materials reduce the energy required to transfer electrons. Their material properties can also be further enhanced through nano-engineering of the material surface. **Figure 3-20** below shows two simplified schematics for a thermotunneling system.

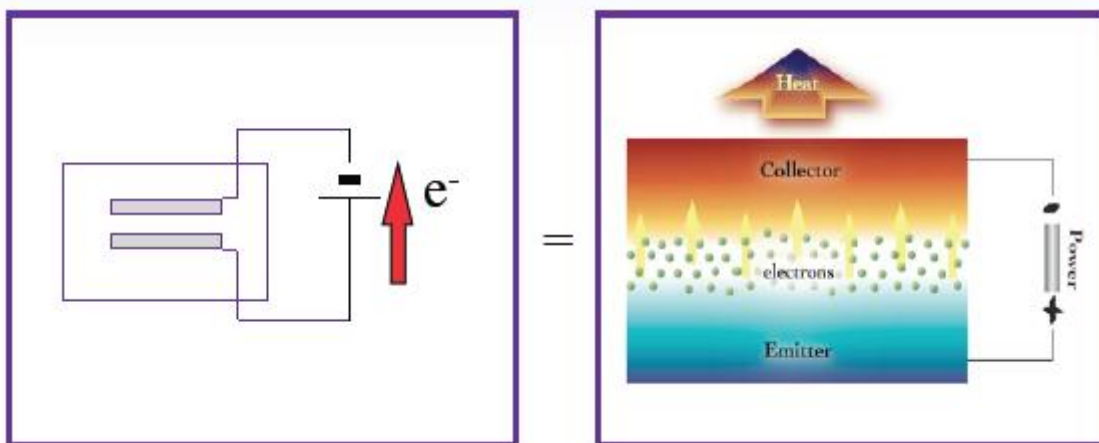

Figure 3-20: Schematic of Thermotunneling System

Source: [Cool](#) Chips PLC, Presentation

For example, Borealis, Inc. uses materials called “Avto Metals” that are engineered with nano-structures on the order of magnitude of an electron wavelength. This structure induces more tunneling and reduces wave scattering by the electrons (Cool Chips PLC, Website).

- *Energy-Efficiency Advantages*

Solid-state cooling systems do not rely on vapor compression to generate the cooling effect, and the energy required to drive the temperature differential can be much lower. The efficiency of the system is driven by the efficiency of the thermoelectric materials. GE indicated that their theoretical modeling showed the potential of thermotunneling cooling systems to have 80% Carnot efficiency, with cooling densities greater than 100W/cm² (Weaver).

The use of a vacuum gap eliminates the conduction heat losses that limit the efficiency of conventional thermoelectric systems.

- *Peak-Demand Reduction and Other Non-Energy Benefits*

For technologies that can provide air-conditioning, we assumed that savings associated with peak demand would mirror savings associated with overall demand. We assumed that peak demand highly correlates with air-conditioning demand.

According to GE, thermotunneling cooling systems offer the following non-energy advantages over conventional systems (Weaver):

- Extreme reliability (no moving parts or compressed fluid)
- No emissions
- No maintenance based on refrigerant levels
- Silent operation
- Orientation-insensitive system

Energy-Savings Potential

- *Potential Market and Retrofit Applications*

Thermotunneling cooling systems are a direct alternative to vapor-compression cooling and heat pump systems. New and existing buildings could use thermotunneling cooling in all heating and cooling applications as either the primary cooling source of cooling, or as a supplemental addition to conventional systems.

Based on these observations, our analysis assumes that this technology applies to the following building stock:

- All climate zones
- All building sizes
- All building types
- All cooling and heat pump applications
- Electric Applications
- Savings apply to full system energy use

- *Energy Savings*

Based on an analysis of its potential impact on HVAC systems in the U.S., this technology would save no Quads of natural gas, and 0.102 Quads of electricity per year.

GE estimated efficiency gains of about 35% over conventional vapor-compression systems for mature thermotunneling systems (accounting for ancillary devices). They also estimate that these systems have the potential to offer energy efficiency (relative to Carnot) of 1.5 or 2 times the typical system (Weaver).

Borealis noted that, accounting for intrinsic and practical loss terms, thermotunneling cooling should achieve 50-55% of Carnot efficiency (and estimated that compressors are generally 40-50% of Carnot efficiency), resulting in 0-15% efficiency savings. **Table 3-18** summarizes the different efficiency levels (based on Carnot efficiency) found in thermotunneling and conventional equipment.

Table 3-18: Efficiency of Various Cooling Systems compared to Carnot

System	% Efficiency compared to Carnot
Current Thermoelectric Systems	15%
Current Compressors	45%
Potential Thermotunneling Systems	55%
Source: Cool Chips PLC, Presentation	

Cost and Complexity

According to GE, mature thermotunneling cooling systems could compete with current vapor-compression units (in terms of cost). GE estimated costs for a thermotunneling system (with auxiliary systems for thermal management) are about \$0.408-\$0.508 per Watt (Weaver). This cost compares favorably to current vapor-compression costs, which are about \$2 per Watt.

As part of this estimate, GE estimated costs for thermotunneling chips at \$0.10 per Watt of cooling power, assuming a semiconductor building cost of \$9/cm² and a maximum cooling power of 100 W per cm² (Weaver).

With a cost per chip of \$0.10 per Watt, a three ton cooling system could cost about \$1000 for the cooling component and a five ton system would cost above \$1,750 for the chips (Sachs, 2004). With auxiliary systems, the total system is likely to cost around \$5,000 for a three ton unit and close to \$9,000 for a five ton unit. This represents a premium of around 20% over a conventional three ton vapor-compression system.

Technical Maturity and Perceived Barriers to Market Adoption

This technology is not commercially available and presents a few significant technical issues that require long-term R&D efforts before they are resolved. Continued basic research is needed for

thermotunneling cooling to become a viable alternative to conventional vapor compression technology.

The limited understanding of the quantum mechanical effects involved and the nano-scale surface interactions of the materials is a barrier to the development of viable thermotunneling cooling systems (Brown, 2010). The difficulty of quantifying losses from thermal radiation also presents a major barrier to development.

GE noted that several manufacturing paths for these systems are available, and only a few were explored during GE's research program. Issues include sealing of the chip (to create the vacuum), adhesion of materials, and thickness control. In addition, low work-function materials need to be characterized so they can be used in the fabrication process (Weaver).

Next Steps for Technology Development

GE recently undertook a 3-year research project on the technology, but did not produce a working prototype, despite a few attempts. GE identified several design concerns, including accounting of thermal losses due to radiation and selection of appropriate low work-function materials and structures. GE did perform modeling of the proposed designs but their results were limited by their understanding of the quantum processes. In particular, one large limitation was that they were unable to determine appropriate values for the radiation losses across the vacuum gap. (Weaver)

Private companies such as Borealis Exploration Limited and Tempronics, Inc. have also been investigating applications for thermotunneling technology. Borealis Exploration Limited in particular has licensed the name "Cool Chips" for their thermotunneling technology. Borealis Exploration Limited reports that they have proof of concept prototypes and are looking to make commercial prototypes (Cool Chips PLC, Website). PNNL noted that they have not developed a prototype despite the large amount of patents, suggesting that further development work is needed (Brown, 2010).

Some of the advances that must occur for this technology to be viable include (Brown, 2010):

- Research and development of designs that establish and maintain nanometer-scale gaps over larger areas, keeping electrode materials clean during fabrication and assembly
- Development of low work-function materials for thermotunneling designs
- Development of more thermally resistant semiconductor materials for designs using nano-structured superlattices
- Development of more precise control of the energy levels of emitting electrons

Table 3-19 presents the potential next steps for thermotunneling cooling cycles to gain greater market attention and acceptance.

Table 3-19: Recommended Next Steps for the Development of Thermotunneling Cooling System

Initiatives	Lead Organization(s)
Research and develop designs for modules employing nanometer-scale vacuum gaps over larger areas than currently demonstrated	DOE, Academic Institutions
Research and development of viable low-work function materials for use in thermotunneling systems	DOE, Academic Institutions
Research and develop new optimized fabrication techniques for thermotunneling systems using alternative materials	DOE, Manufacturers
Quantify and reduce the amount of radiation heat transfer across the vacuum gap of a thermotunneling system	DOE, Academic Institutions

Sources: GE, PNNL

References

Brown, DR. et al. “The Prospects of Alternatives to Vapor Compression Technology for Space Cooling and Food Refrigeration Applications.” PNNL-19259. PNNL. March 2010. Prepared for the U.S. DOE under contract DE-AC05-76RL01830.

Sachs, H. et al. “Emerging Energy-Saving Technologies and Practices for the Building Sector as of 2004.” October 2004. Report Number A042. ACEEE.

Weaver, Stan et al. “Thermotunneling Based Cooling Systems for High Efficiency Buildings.” Final Technical Report. GE Global Research. DE-FC26-04NT42324.

Cool Chips PLC, Presentation. “Cool Chips – Technical Overview.” <http://www.coolchips.gi/technology/Coolchipstech3Jan06.pdf>

Cool Chips PLC, Website. <http://www.coolchips.gi/about.shtml>

3.3 Thermal Distribution Systems

Technologies in this category reduce duct-leakage losses and maximize the performance of thermal distribution systems that deliver space conditioning to building occupants. This category includes:

- Aerosol Duct Sealing
- Demand-Controlled Ventilation
- Duct-Leakage Diagnostics
- Ductwork in Conditioned Space
- Thermal Displacement Ventilation.

3.3.1 Aerosol Duct Sealing

Brief Description	Aerosol duct sealant systems are used to find and plug air holes in ducts, without having to locate them first. The system pushing an adhesive-aerosol sealant through the duct network and deposits the sealant in the holes. The technology reduces the leakage in a building, which reduces the load on the building’s cooling and air delivery systems.		
Technical Energy-Savings Potential (Quads/year)	Market Readiness	DOE Priority	
0.61 Quads/year	High	Low	

Summary

A typical building HVAC system consists of thousands of field-assembled joints that are susceptible to leakage based on the quality of the materials and the installation. LBNL studies reported that commercial buildings lost on average 10% to 20% of the total air delivered by the supply fan, which can result in significant system efficiency losses (Hamilton, 2003). One potential solution to eliminate air leaks is to use an aerosol duct leaking system to seal most of the holes in the duct system.

To implement the system, the duct network is sealed and pressurized, and aerosol duct sealant is sprayed into the ductwork. A fan drives the spray through the system, the aerosol collects at holes in the ductwork, and each hole is eventually sealed. The aerosol sealant system can fill holes up to 1 inch across, but cannot be used in certain duct features (i.e. VAV terminals).

Aerosol duct sealant systems are a commercialized technology that is applicable to any ducted HVAC system. The high cost of the technology is the main barrier to additional market adoption. Significant cost-reduction efforts and incentive programs are necessary to encourage the wide-scale adoption of these systems, as well as development efforts to extend the technology to hard-to-reach areas of the ductwork system.

Table 3-20 summarizes the characteristics, technical energy-savings potential, and research status of this technology.

Table 3-20: Summary of the Characteristics of Aerosol Duct Sealing

Attribute	Value	Comments
Systems Impacted	All cooling and heating ducted systems	
Fuel Type	Electricity and Gas	Improvements to ducting system will impact all ducted systems
Relevant Annual Energy Consumption	6.69 Quads/yr	Consumption from all heating, cooling, and ventilation applications (whole system); gas and electric fuel sources; all building types in all climates; high retrofit potential means wide adoption by existing buildings
Technical Energy-Savings Potential	0.61 Quads/yr	Applied to relevant annual energy consumption by increasing system efficiency by 10%
Peak Demand Reduction	Medium	Peak demand savings for this technology follow the air-conditioning savings offered
Technical Maturity	Emerging	Product is offered commercially, but has been mainly applied to residential homes
Retrofit Potential	High	Targeted at existing cooling and heating ducted systems
Non-energy Benefits	<ul style="list-style-type: none"> - Improved Indoor Air Quality - Improved Comfort 	
Most Promising Applications	Commercial buildings with smaller duct networks and no VAV boxes	
Next Steps for Technology	<p>Need development to address challenges in the implementation of this technology, such as:</p> <ul style="list-style-type: none"> • Develop alternative methods for applying technology to complex duct systems (VAV boxes, electric resistance elements) to ease complex installations • Support development of improved methods for commissioning of existing buildings (duct leakage and poor duct supports) <p>Also:</p> <ul style="list-style-type: none"> • Create financial incentives to implementation through utility incentive programs 	

Background

- *Duct-Leakage Problem*

Commercial buildings that generate cooling and heating usually deliver conditioned air to the building interior through a duct network. These duct networks contain thousands of field-assembled joints that are susceptible to air and heat leakage based on the quality of the materials and the installation (Conant, 2004). Surveys and field studies have demonstrated that a typical building experiences both air leaks due to holes, and heat leaks due to poorly installed insulation. In addition, leakage losses that occur in unconditioned spaces contribute directly to the inefficiency of the system.

The BAIHP study surveyed 75 homes in the program. It stated that, on average, 56% of the leakage of the return and supply ductwork was to unconditioned spaces (McIlvaine, 2006).

LBL's study noted that, based on surveys of nine different commercial buildings, branch ducts tend to be leakier than main ducts (Conant, 2004). LBNL measured the average duct leakages shown in **Table 3-21** below.

Table 3-21: Typical Leakages in Building Ducts for LBNL Study

Leakage Source	Leakage Value (L/s*m2)
Suggested ASHRAE unsealed leakage	2.5
Average for all main branches	4
Average for all branches	9
Average for systems	13
Range for all systems	0.5 to 41

Source: LBNL

LBL's study also measured the ratio of the leakage rate to the overall duct flow rate. The study indicated that 70% (7 of 10) of the buildings experienced high amounts of leakage (defined as 9% to 26% of the airflow), and the remaining buildings experienced less than 5% leakage (Conant, 2004).

The existence of leaks will either cause the building's conditioning system to underperform, or cause it to exert additional energy to overcome the losses. Scientists at Washington State University noted that a typical residential HVAC design (which included locating supply and return ducts in unconditioned space) resulted in an efficiency loss of 20% in typical installations (as assumed by ICC 2006). Removing the inefficiency through proper insulation and relocation to conditioned spaces could result in 96% network efficiency (Lubliner, 2008).

Technology Description

Sealing of duct leaks in a commercial building would result in significant energy savings. However, manually finding and plugging the leaks is an expensive and time-intensive task. Aerosol duct sealing is an easier technique for sealing holes in the building ductwork.

Aerosol duct sealing systems use an adhesive-aerosol spray. The spray is designed to accumulate when it comes in contact with holes in the ductwork, thereby sealing them. The ductwork system must be sealed and pressured prior to implementation. When implementing, an atomizer sprays the adhesive-aerosol spray into the ductwork as a solution suspended in air. Driven by an induced pressure differential inside the duct system, the adhesive-aerosol spray flows through any openings or cracks in the ductwork, accumulating at each spot and eventually sealing the hole (Hamilton, 2003).

The Aerosol duct sealing system can be adapted to any ductwork system by varying the aerosol particle size (Conant, 2004). For each implementation, the duct pressurization level and the airflow are optimized to ensure proper sealing. The system itself consists of (Aerosol, LLC):

- Adhesive-aerosol sealant (Aerosol Corp. uses a mixture of vinyl acetate polymer and 2-ethyl-1 hexanol)
- Aerosol atomizer to inject atomized sealant into the duct system
- Foam Plugs to seal the access points
- Computer controls for monitoring the process

Figure 3-21 shows all the different components in an aerosol duct sealing system.

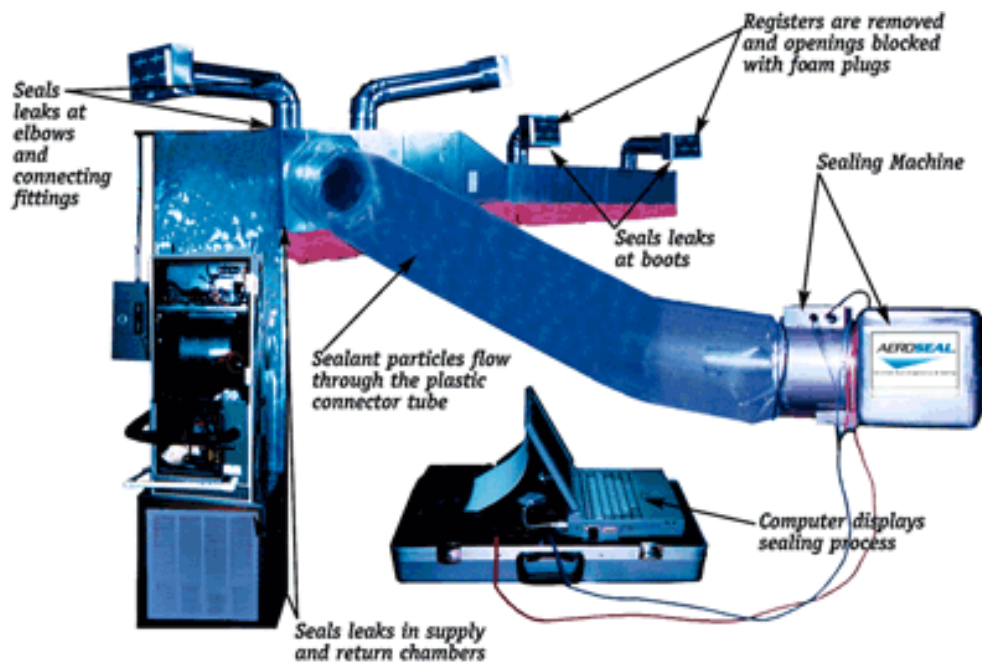

Figure 3-21: Aerosol Duct Sealing System setup (from AeroSeal)

Source: AeroSeal Corp.

The aerosol sealant system is designed to keep the adhesive-aerosol spray suspended in the air until the spray reaches the duct leak openings. To deliver the adhesive-aerosol sealant to the leaks, the sealant is broken up into large particles that are injected into the moving airstream (LBNL). The moving air stream ensures that the particles stay suspended in the air (without depositing on the interior of the duct) (AeroSeal, LLC). Once the airstream reaches a leak, the air

enters the hole with a sharp turn. The adhesive-aerosol sealant particles follow the air, but run into the edges of the duct; thus, they are deposited in the hole, and slowly accumulate to fill the gap (LBNL).

The aerosol sealant system can fill holes up to 1 inch across, though Aero seal recommends using their system only for filling holes up to 5/8 in. They mentioned that the sealing time varies with the size of hole. Aero seal also mentioned that the system can be used with any kind of ductwork, though using it with ductwork containing extensive interior lining is not recommended (Aero seal, LLC).

- *Energy-Efficiency Advantages*

Duct leakage can result in higher HVAC energy consumption through a number of different paths. Air leaks remove conditioned air from the system, requiring the HVAC system to expend more energy producing additional conditioning to meet building loads (building owners may also oversize their systems to compensate). Leaks also reduce the air pressure within the duct system, resulting in slower moving air; systems fans may need to run longer or faster to compensate for this reduction.

Aerosol duct sealing systems will significantly reduce duct leakage, restoring the pressurization within the ductwork and preventing escape of conditioned air.

- *Peak-Demand Reduction and Other Non-Energy Benefits*

For technologies that can provide air-conditioning, we assumed that savings associated with peak demand would mirror savings associated with overall demand. We assumed that peak demand highly correlates with air-conditioning demand.

U.S. EPA noted that sealing ducts using aerosol duct sealing systems provides several advantages over a conventional system, including (EPA, 2000):

- Improved comfort
- Improved air quality
- For new construction and extensive retrofits, lower equipment and installation costs due to proper sizing of equipment and ductwork

An LBNL survey also noted the following positive effects that lead to improved air quality (Siegel, et al.):

- Reduction of condensation and mold growths on the ducts
- Elimination of pollution by outside air

Energy-Savings Potential

- *Potential Market and Retrofit Applications*

The aerosol duct sealing system is intended mainly to service existing buildings using ducted systems. The system could be used in any system that uses ducted networks to move conditioned air; duct systems with 1-inch leak holes or smaller are an especially attractive application.

We assumed that the building stock this technology applies to includes:

- All climate zones
- All building sizes
- All building types
- All cooling, heating, and ventilation applications
- Gas and Electric Applications
- Savings apply to full system energy use

- *Energy Savings*

Based on an analysis of its potential impact on HVAC systems in the U.S., this technology would save 0.184 Quads of natural gas, and 0.424 Quads of electricity per year.

According to previous studies of commercial buildings cited by LBNL, existing duct leakage and conduction losses in light commercial buildings caused an average drop of 37% in overall cooling efficiency. They state that these efficiency losses can be halved through more effective duct sealing methods (Conant, 2004).

According to Hamilton et al., Aerosol duct sealing can reduce system energy consumption by 4% to 9%, by reducing the duct-leakage rate down between 2% and 3% (from typical rates of 10% to 20%) (Hamilton, 2003).

Aeroseal Corp. estimated that the Aeroseal duct sealing system could save 10-30% of HVAC energy use in light commercial buildings and 5-10% of cooling energy use in large commercial buildings with VAV (20-40% of fan energy use). They also provided estimated payback periods of 1 to 4 years for this technology (Aeroseal, LLC).

Cost and Complexity

According to Hamilton et al., implementation of an aerosol duct sealing process costs about \$0.40 per square foot of floor space. The process is significantly labor intensive. They noted that, based on this cost, the payback period is generally about 10 years.

According to ACEEE, the average of cost of using an aerosol duct sealing system in residential homes was slightly over \$1,000 (for a study of 121 Sacramento homes), but they noted that this estimate may have included other remediation work. They estimated a mature market cost of \$500 to \$900 per residence (Sachs, 2004).

Technical Maturity and Perceived Barriers to Market Adoption

This is a commercially available technology. Aeroseal LCC is a manufacturer and implementer of the Aeroseal duct sealing system; they were acquired by Carrier Corporation in 2001. Implementation has mainly focused on the residential sector.

Aeroseal duct sealing systems are a commercially available technology, but require some additional work to make them viable in every commercial setting. Systems with VAV boxes can

make implementation of the aerosol system burdensome; additional work is needed to reduce the complexity of implementation in large commercial buildings.

In addition, effective commissioning of ductwork systems is required to guide implementation of this technology and present market opportunities for this technology. This includes commissioning to uncover leaky systems and commissioning to reveal poorly supported duct systems. Poorly supported duct systems are prone to sagging and bending. While aerosol duct sealing systems can repair the holes that are symptoms of this condition, repairs may not last under continual stress caused by poor support (Roth, 2002).

Next Steps for Technology Development

ACEEE and LBNL noted that the aerosol duct sealing system had been commercialized by Aeroseal Corp. The technology was licensed from Lawrence Berkeley National Labs (LBNL). ACEEE noted that the cost of the technology is expensive relative to consumer expectations, although, Aeroseal noted that it has worked on several commercial building installations (Sachs, 2004). Utility incentive programs may help reduce the initial costs of implementing this technology.

Additional commissioning of existing ductwork systems for excessive leakage and poor support will also encourage adoption of the technology. This should be performed in parallel with education of building owners. Finally, stakeholders should support additional commercial projects to demonstrate the effectiveness and long-term reliability of the technology.

Duct-leakage diagnostic systems were selected as one of the priority technologies for in-depth analysis, and are profiled in Section 0.

Table 3-22 presents the potential next steps for aerosol duct sealing systems to gain greater market attention and acceptance.

Table 3-22: Recommended Next Steps for the Development of Aerosol Duct Sealing Systems

Initiatives	Lead Organization(s)
Create financial incentives to implementation through utility incentive programs	Utilities
Develop alternative methods for applying technology to complex duct systems (VAV boxes, electric resistance elements) to ease complex installations	Manufacturers
Support additional field demonstrations for long-term data collection	DOE, Manufacturers
Support development of improved methods for commissioning of existing buildings (duct leakage and poor duct supports)	DOE, Manufacturers

References

Aeroseal, LLC. “Frequently Asked Questions – Commercial.”
<http://www.aeroseal.com/problem-we-solve/FAQ-commercial.html>.

Conant, Abram et al. “Comprehensive Diagnostic and Improvement Tools for HVAC-System Installations in Light Commercial Buildings.” Proctor Engineering Group. Final Report. October 31, 2004. NETL. DE-FC26-01NT41256.

EPA, 2000. “Locating Ducts within Conditioned Space – Air Distribution System Improvements.” U.S. EPA. EPA 430-F-97-028. December 2000.

Hamilton, Saphir et al. “Improved Duct Sealing.” Emerging Technologies, ASHRAE Journal. May 2003.

LBNL. “Aeroseal Duct Sealing.” LBNL – From the Lab to the Marketplace.
<http://eetd.lbl.gov/12m2/aerosol.html>

Lubliner, Michael et al. “Moving Ducts Inside: Big Builders, Scientists Find Common Ground.” Washington State University. 2008 ACEEE Summer Study on Energy Efficiency in Buildings.

McIlvaine, J. et al. “Building America Industrialized Housing Partnership (BAIHP).” Final Project Report. University of Central Florida / Florida Solar Energy Center. October 2006. FSEC-CR-1663-06.

Roth, K. et al. “Energy Consumption Characteristics of Commercial Building HVAC Systems Volume III: Energy Savings Potential.” TIAX LLC, TIAX Reference No. 68370-00. Building Technologies Program. July, 2002

Sachs, H. et al. “Emerging Energy-Savings Technologies and Practices for the Buildings Sector as of 2004.” ACEEE. October 2004. Report Number A042

Siegel, Jeffery and Walker, Ian. “Integrating Ducts into the Conditioned Space: Successes and Challenges.” University of Texas at Austin, LBNL.

Wray, C.P., Diamond, R.C., and Sherman, M.H. “Rationale for Measuring Duct Leakage Flows in Large Commercial Buildings.” LBNL, Environmental Energy Technologies Division. July 2005. LBNL-58252.

3.3.2 Demand-Controlled Ventilation

Brief Description	Demand-controlled ventilation (DCV) eliminates excessive outdoor airflow when building occupancy falls below peak-design levels. By providing the required amount of ventilation based on actual occupancy, DCV maintains indoor air quality while consuming less energy.	
Technical Energy-Savings Potential (Quads/year)	Market Readiness	DOE Priority
0.09 Quads/year	High	Medium

Summary

Commercial buildings require ventilation to maintain good indoor air quality (IAQ) and provide a suitable environment for occupants. This requires energy-intensive conditioning to bring the outdoor air to the appropriate temperature and humidity levels to meet indoor comfort needs. Demand-controlled ventilation (DCV) senses carbon-dioxide (CO₂) concentrations or uses other strategies to determine the occupancy of each building HVAC zone, and accurately matches the ventilation requirement. By reducing ventilation to minimal levels when occupancy is low, DCV maintains high indoor air quality while consuming less energy. DCV can reduce energy consumption by 10-30% in buildings having varying occupancy schedules, high HVAC requirements, and/or long hours of operation. Manufacturers have begun offering DCV capabilities in many of their packaged HVAC equipment, reducing installation complexity. The high cost and reliability of the CO₂ sensors impeded the adoption of DCV, although next generation sensor technology should lower these barriers.

Table 3-23 presents a summary overview of demand-controlled ventilation for commercial buildings.

Table 3-23: Summary of Demand-Controlled Ventilation (DCV) Characteristics

Attribute	Value	Comments
Systems Impacted	Building ventilation systems	
Fuel Type	Gas and Electricity	
Relevant Annual Energy Consumption	0.94 Quads/yr	
Technical Energy-Savings Potential	0.09 Quads/yr	
Peak Demand Reduction	Varies	DCV lowers system demand when the building has lower occupancy. This will depend on the specific building schedule.
Technical Maturity	Comm. Available	
Retrofit Potential	High	Installation typically requires sensor placement, and wiring the damper controller
Non-energy Benefits	<ul style="list-style-type: none"> - Improved comfort - Maintains IAQ - Fault detection for ventilation system 	
Most Promising Applications	Buildings that feature: <ul style="list-style-type: none"> - Sealed building envelope - Variable occupancy - High heating/cooling loads - Long hours of operation - Sizable ventilation requirement 	
Next Steps for Technology	<ul style="list-style-type: none"> - Create a database of building occupancy patterns across the U.S. to determine which building types would benefit most - Develop more reliable and cost-effective sensors for HVAC applications as well as sensors capable of detecting multiple causes of poor IAQ - Determine the effectiveness DCV using CO₂ sensors on IAQ where there are other possible contaminants present 	

Background

- *Technology Description*

To ensure proper indoor air quality (IAQ) and control airborne contaminants, ventilation systems bring fresh outdoor air (OA) into buildings. The HVAC system must then condition the incoming OA to a suitable temperature and humidity for use inside the building. The amount of ventilation required in a space depends on the number of people present as mandated by building codes. Typically designed for maximum occupancy, the ventilation system can provide excessive amounts of OA during low-occupancy hours. Buildings in which occupancy varies can save energy by more accurately matching the supplied ventilation with code requirements. This concept of demand-controlled ventilation (DCV) modulates the amount of OA provided to occupants based on the measured or anticipated requirement.

The DCV system supplies the necessary ventilation airflow based on a specific demand signal. Strategies to determine the amount of OA needed for a space include:

1. Carbon-Dioxide Sensors – DCV systems most often sense carbon-dioxide (CO₂) levels to determine ventilation requirements. System controllers compare CO₂ levels to a set-point concentration and, if above the limit, dampers open to bring in additional ventilation air. This set-point can be predetermined or based on the differential between outdoor and indoor CO₂ concentration levels.
2. Other Occupancy Sensors – Other methods can be used to infer occupancy levels and control ventilation. Motion sensors detect movement, infrared sensors detect the presence of body heat, and sound sensors detect human speech. Typically these methods would be used in smaller zones of the building (such as conference rooms) that fluctuate between an empty room and full occupancy. Because of their single level of detection, these sensors fail to identify various occupancy levels and are not accurate enough for many DCV cases. For example, a motion sensor cannot distinguish between 2 or 10 people.
3. Information-Based Occupancy Detection –If the building operator can anticipate a specific occupancy pattern, the building management system can control the ventilation according to that schedule. For example, a theatre operator can anticipate the number of people in the building based on the number of tickets sold. As a backup, this type of ventilation control should allow for building operators to change system settings due to unanticipated activities as well.

Each of these methods inherently carries positive and negative attributes with the specific building needs determining the optimum detection strategy. Because the majority of DCV systems utilize CO₂ sensors, the remaining discussion focuses on applications using CO₂ sensors.

To more accurately determine the ventilation needs of a building, DCV systems monitor the occupancy of each building zone according to the measured CO₂ concentration. CO₂ is measured in parts per million (ppm) with normal outdoor CO₂ levels ranging from 300-500 ppm, and indoor concentrations of 400-900 ppm. In general, maintaining indoor CO₂ concentration to 700 ppm above the outdoor ambient concentration provides suitable occupant comfort. (Jeannette and Phillips, 2006). Although the number of CO₂ sensors varies for each application, each building zone operated by a separate air handler should have its own sensor. **Figure 3-22** demonstrates the possible layout of a CO₂ sensor in each zone.

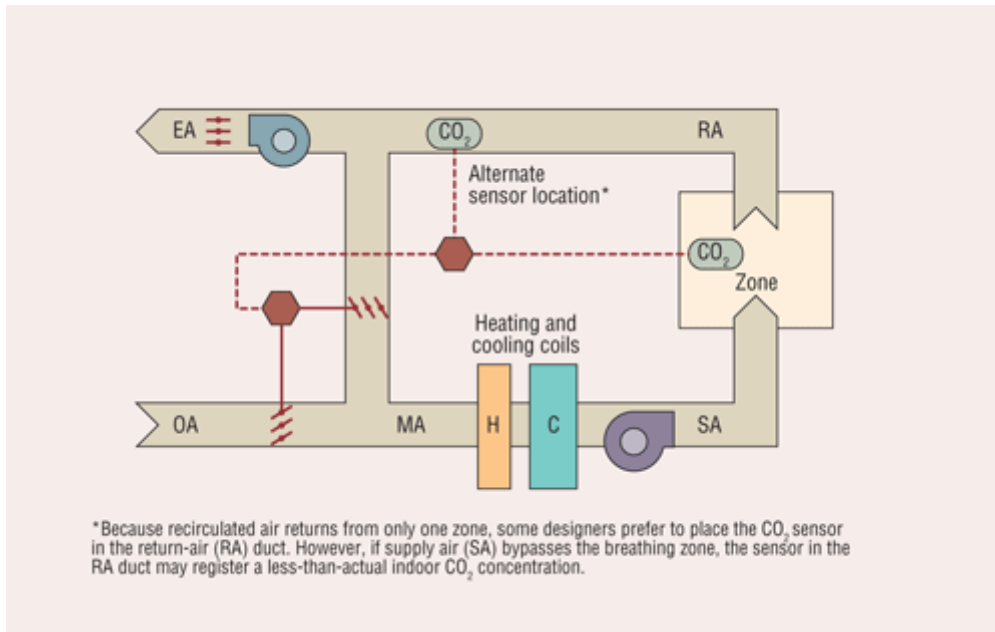

Figure 3-22: Typical CO₂ Sensor Placement in a DCV System

Source: Murphy and Bradley (2008)

The CO₂ sensor can be placed either in the conditioned space near occupants or in the return air ductwork. Locating the sensor in the specific comfort zone measures the conditions the occupants encounter, but can give inaccurate readings if placed near windows, doors, or supply ducts. Having the sensor inside the return duct measures the concentration averaged over a larger area, but can be compromised by duct system designs that bypass excess supply air to the return-air system. The DCV system lowers the amount of ventilation entering the space until the CO₂ concentration reaches the set-point (or the minimum ventilation rate established). When this happens, the DCV controller modulates a ventilation damper, bringing in additional OA until the measured CO₂ concentration drops below the set-point again.

- *Energy-Efficiency Advantages*

In a conventional system, ventilation is continuously supplied throughout the day at a rate determined by the building's design maximum occupancy. Because buildings experience varying occupancy throughout their operations, providing only the needed ventilation minimizes its associated energy usage. DCV detects occupancy levels and adjusts the ventilation rate to match the code requirements as occupancy changes. By controlling the ventilation rate, the energy to condition and/or dehumidify the incoming air is minimized.

- *Peak Demand Reduction and Other Non-Energy Benefits*

Because DCV provides building energy savings during low-occupancy periods, possible peak-demand reduction will depend on the building occupancy schedule. DCV controls and measures IAQ directly with sensors instead of previous design assumptions. This possibly can result in higher IAQ and increased occupant comfort. If the ventilation system experiences a fault, the CO₂ sensors would detect a rise in concentrations, alerting building staff.

Energy-Savings Potential

- Potential Market and Retrofit Applications

Very few buildings operate continuously at their design occupancy conditions, allowing DCV to benefit much of the U.S. building stock. The most promising commercial buildings include those that have:

- Sealed building envelope
- Variable occupancy
- High heating/cooling loads
- Long hours of operation
- Significant ventilation requirement for at least a portion of operations

DCV can be retrofit into most existing HVAC systems by installing the necessary control equipment. Installation involves the placement of sensors, wiring to DCV controls, and system commissioning. Many manufacturers offer DCV-compatible packaged equipment.

- Energy Savings

Jeannette and Phillips (2006) examined various case studies for buildings having DCV. They noted that a 30-78% reduction in OA is possible if DCV is used during low-occupancy hours. An office building using DCV could achieve yearly savings of \$.11/sq.ft.

Won and Yang (2005) estimated office buildings could reduce HVAC energy use 20-30% by incorporating DCV schemes.

Apte (2006) evaluated using DCV in a variety of building types to provide high IAQ levels with minimal energy input. He found that DCV reduces overall HVAC consumption by about 10% while providing superior IAQ.

Based on an analysis of its potential impact on HVAC systems in the U.S., this technology would save 0.09 Quads of energy per year.

Cost and Complexity

The cost of DCV systems will vary with the building configuration and HVAC system. The CO₂ sensors typically have been the largest single cost, and will determine the complexity of the DCV project. Obviously more building zones require more sensors, and add to project complexity.

Stipe (2003) examined the use of DCV in Oregon. He found that DCV would cost \$300-1000 per zone depending on the type of HVAC equipment, often with an expected payback of 2 years.

E Source (2005) notes that CO₂ sensors available for \$200-\$400 each provide a 10-15 year lifetime. **Table 3-24** summarizes the payback for simulated DCV projects

Table 3-24: Summary of Simulated Payback with DCV [E Source (2005)]

Location	Payback for Offices (yrs)	Payback for Restaurants (yrs)	Payback for Retail Stores (yrs)	Payback for Schools (yrs)
Oakland, CA	6.8	2.1	1.0	4.0
El Centro, CA	1.9	0.6	0.3	0.9
Phoenix, AZ	3.4	0.9	0.6	1.5
Charleston, SC	1.1	0.7	0.4	0.9
Fargo, ND	1.5	0.3	0.2	0.5

Sand (2004) studied the various U.S. installations of DCV and their usage. He found that CO₂ sensors typically retailed for \$200-250 with installation costs of \$600-700 per zone for new construction. For retrofit situations, he determined that systems using direct digital controls (DDC) cost \$700-900 per zone while those using pneumatic controls cost \$900-1200 per zone.

Hong and Fisk (2010) modeled DCV for various office buildings in 5 California climates. They estimated typical installation costs of \$617 per zone and an average total cost of \$.173/sq.ft.

Technical Maturity and Perceived Barriers to Market Adoption

This is a commercially available technology. Packaged HVAC equipment offered by numerous manufacturers features DCV as a factory or field configurable option. DCV relies greatly on individual sensors that can lose precision over time and often require yearly calibration. In recent years, sensor technology has improved to allow for longer time between calibrations (often 3-5 years) and some even have lifetime self-calibration. OA infiltration through the building envelope can cause false sensor readings. Buildings that have non-occupant produced contaminants should not use DCV because the sensors typically are not equipped to detect the presence of other pollutants. CO₂ is not the only indicator of IAQ, and DCV may not protect against the buildup of other harmful gases and volatile organic compounds (VOCs).

Next Steps for Technology Development

Table 3-25 presents the potential next steps for DCV to gain greater market attention and acceptance.

Table 3-25: Recommended Next Steps for the Development of Demand-controlled Ventilation

Initiatives	Lead Organization(s)
Create a database of building occupancy habits across the U.S. to determine which building types would benefit most	DOE, Industry Organizations, Utilities
Develop more reliable and lower-cost sensors for HVAC applications as well as sensors capable of detecting multiple causes of poor IAQ	DOE, Manufacturers
Determine the effectiveness DCV using CO ₂ sensors on IAQ where there are other possible contaminants present	DOE, Industry Organizations

References

Apte, Michael. 2006. “A Review of Demand Control Ventilation.” Lawrence Berkley National Laboratory. LBNL-60170.

E Source. 2005. “Using Demand-Controlled Ventilation to Reduce HVAC Costs.” E Source Companies LLC.

Hong and Fisk. 2010. “Assessment of Energy Savings Potential from the Use of Demand Controlled Ventilation in General Office Spaces in California.” Lawrence Berkley National Laboratory. DOE Contract No. DE-AC02-05CH11231.

Jeannette and Phillips. 2006. “Designing and Testing Demand Controlled Ventilation Strategies.” National Conference on Building Commissioning.

Murphy and Bradley. 2008. “CO₂-Based Demand-Controlled Ventilation with ASHRAE Standard 62.1” HPAC Engineering. Sept. 1, 2008. Retrieved from <http://hpac.com/fastrack/fastrack-murphy-09-10-08/>.

Sand, James. 2004. “Demand-Controlled Ventilation Using CO₂ Sensors.” Federal Energy Management Program. U.S. Department of Energy. DOE/EE-0293.

Stipe, Marty. 2003. “Demand Controlled Ventilation: A Design Guide.” Oregon Office of Energy. June 2003.

Won and Yang. 2005. “The State of-the-Art in Sensor Technology for Demand-Controlled Ventilation.” NRC-CNRC. IRC-RR-243.

3.3.3 Duct-Leakage Diagnostics

Brief Description	Leakage in commercial HVAC duct systems wastes energy associated with fan usage and thermal conditioning. Diagnostic testing methods exist to alert building operators of the presence of leaks so they may be repaired.	
Technical Energy-Savings Potential (Quads/year)	Market Readiness	DOE Priority
0.30 Quads/year	Medium	Low

Summary

Duct-leakage in commercial building HVAC systems wastes upwards of 10% of fan and thermal energy by losing both airflow and conditioning outside the usable space. A number of techniques exist to diagnose branches of ductwork for leakage including the pressurization test, Delta Q test, and the tracer gas test. Duct-leakage testing detects the presence of gaps or holes in ductwork so that the problems can be remediated, improving system efficiency. Although the benefit of duct-leakage diagnostics and remediation depends on a number of building-specific factors, duct-leakage testing and repair has an attractive payback when performed as part of building retrocommissioning. Originally developed for residential applications, the size and complexity of commercial building HVAC systems inhibit wider acceptance of duct-leakage testing. Improvements in diagnostic strategies specifically designed for commercial systems are required to minimize losses known to exist. Investigating the building and HVAC system types most prone to duct-leakage can help quantify the benefits of tighter ducts.

Table 3-26 presents a summary overview of duct-leakage diagnostics for commercial buildings.

Table 3-26: Summary of the Characteristics of Duct-Leakage Diagnostics

Attribute	Value	Comments
Systems Impacted	Ducted commercial HVAC systems	
Fuel Type	Electricity and Gas	
Relevant Annual Energy Consumption	4.03 Quads/yr	
Technical Energy-Savings Potential	0.30 Quads/yr	
Peak Demand Reduction	Varies	Any cooling energy savings will have a peak demand component
Technical Maturity	Emerging	
Retrofit Potential	High	
Non-energy Benefits	<ul style="list-style-type: none"> - Improved occupant comfort - Better IAQ - Reduced noise levels 	
Most Promising Applications	<ul style="list-style-type: none"> - Buildings where main duct branches are not located in the conditioned space 	
Next Steps for Technology	<ul style="list-style-type: none"> - Conduct field testing to determine which building types would see the greatest benefit - Develop a standard test method and apparatus specifically designed for commercial buildings - Offer incentive programs to building operators 	

Background

- Technology Description

In commercial buildings, ductwork carries conditioned air to and from the occupied space. Poor installation or gaps that form in duct joints over time from thermal or mechanical cycling contribute to duct-leakage. Because most ductwork is hidden from view, and occupants often fail to realize a drop in comfort, leaks can go unnoticed in commercial buildings. In many buildings, conditioned supply air escapes through gaps in ductwork into an unconditioned or partially conditioned space (e.g. the area above a false ceiling). The demand for heating/cooling rises because the thermal energy is lost outside of the intended space. Additionally, fan usage increases to overcome airflow losses in the duct system whether or not the ducts are in conditioned spaces. Leakage in return-air ductwork may introduce contaminants to the airstream, increases fan energy usage, and can raise the thermal lift necessary to recondition the air.

Much work has been done to develop simulations and field tests for duct-leakage in residential systems but little for commercial buildings (Roth et al. 2005). Commercial HVAC systems are typically more complex and vary widely from building to building with different system designs. When ducts reside in a conditioned space, leaked air at least provides some of the intended energy to occupants although it may lead to air balance or zoning issues. Most ductwork is inside the thermal envelope of larger commercial buildings, but around half of all ductwork in smaller commercial buildings is located outside of the conditioned space (Westphalen et al. 2005).

Because of their complex nature, it can be difficult to detect, measure, and fix duct-leakage problems in commercial HVAC systems.

No continuous diagnostic monitoring system exists yet, but a number of testing methods currently detect duct leakage in commercial buildings (Walker et al. 2010):

- The pressurization test measures the duct leakage for the positive (supply) and negative (return) pressure independently. The duct branch is temporarily sealed, a fan blower is connected to the duct system, stabilizes the pressure inside the section of interest, and then measures the airflow required to maintain that standard pressure. The difference between the expected and actual airflow determines leakage.
- The Delta Q duct-leakage test measures the airflow differential required to pressurize a duct section between the HVAC system's air handler and an external fan blower added for testing. Four tests measure leakage under pressurization and depressurization with the air handler set both on and off. The pressure and airflow differentials are compared to a leakage model.
- The tracer gas test injects a large, measured amount of tracer gas (typically CO₂) into a duct section and monitors airflow conditions. Sensors measure the concentration of the tracer gas at the duct diffuser, and can determine the amount of leakage based on the differential in concentration.

- *Energy-Efficiency Advantages*

The larger size and complexity of commercial HVAC systems (compared to residential systems) often does not allow for testing of all ducts in a building. Leaky ducts located in unconditioned spaces create greater losses compared to those in conditioned space, and provide a greater technical energy-savings potential. These diagnostics detect the presence and amount of duct leakage in building HVAC systems so they may be repaired, eliminating losses. After determining the extent of duct-leakage, methods including physical repair, applying tape, mastic coatings, or aerosol sealants exist to remediate duct-leakage.

One technology used to remediate duct leakage is aerosol duct-leakage systems. This technology was selected as one of priority technologies for in-depth analysis, and is described in Section 3.3.1. Another technology used to remediate duct leakage is moving ductwork into the conditioned space. This technology was also selected as one of priority technologies for in-depth analysis, and is described in Section 3.3.4.

- *Peak Demand Reduction and Other Non-Energy Benefits*

Duct-leakage diagnostics would reduce peak demand associated with the excess fan usage and the additional heating/cooling requirements. Duct-leakage can lower airflow to conditioned spaces. Occupant comfort increases when proper supply and return airflow is provided. Indoor air quality will improve in situations where return air leaks allowed the infiltration of contaminants. Eliminating leakage reduces the noise associated with airflow escaping through gaps and holes in ductwork.

Energy-Savings Potential

- Potential Market and Retrofit Applications

Duct-leakage diagnostic tests would be performed as part of retrocommissioning or other preventive maintenance on an existing building. Potentially all ducted HVAC systems could benefit from leakage testing. The required test equipment would not be permanent or require significant HVAC system modification.

- Energy Savings

Based on an analysis of its potential impact on HVAC systems in the U.S., this technology would save 0.078 Quads of natural gas, and 0.22 Quads of electricity per year.

Roth et al. (2005) estimated that packaged HVAC systems have a 13-26% duct-leakage rate. They noted that larger centralized systems typically have lower duct-leakage rates because of start-up commissioning.

Wray (2003) simulated HVAC performance for buildings with leaky ducts. They found that a 15% duct-leakage rate could be associated with a 25-35% total system energy increase.

Wray et al. (2005) tested a number of commercial buildings in California for duct leakage. They noted that leak tests are typically conducted on high-pressure main ducts and not the low-pressure branch ducts that make up the majority of ductwork. Compared to a reference model, many of the buildings tested had an increase in fan airflow of 9-26% due to duct leakage.

Westphalen et al. (2005) estimated that detecting and repairing duct leakage would save \$0.015 - 0.20/sq.ft. per year. The savings were dependant on the HVAC costs and duct-leakage rate of the building.

Wray and Sherman (2010) modeled a building having a 10% supply and return leakage rate. They found that this leakage rate increased fan energy consumption by 30% and raised HVAC source energy consumption over 8%.

- Cost and Complexity

The economics of duct-leakage diagnostics depend on the scope of investigation, building energy usage, system design, and the degree of leakage. If the majority of ducts are in the conditioned space, diagnosis and repair of leaks may have lower energy savings. Any information that helps direct the diagnostics technician focus on problem duct sections, such as comfort complaints or poor airflow to a certain area, could help lower complexity and cost.

Westphalen et al. (2005) found the cost of the tracer gas method to be \$0.05-0.10/sq.ft. for equipment and labor. The cost to repair the leaks using aerosol sealants or physical repairs is \$0.40-0.50/sq.ft. with an estimated payback of 2.5 to 15 years depending on the particular building.

Technical Maturity and Perceived Barriers to Market Adoption

This is an emerging technology having limited availability in the US market today. The size and complexity of commercial HVAC systems reduces the effectiveness of current leakage detection

technology. These methods are difficult to implement over a large building having numerous duct branches and many diffusers, so the leakage testing is typically limited to select duct sections. This limits the effectiveness of this measure and may under represent the leakage in the building’s entire duct system.

Duct-leakage diagnostics for commercial building HVAC systems has a high upfront cost because of the large amount of labor and equipment required to investigate the expansive duct systems that are typically in commercial buildings. The extent of the leakage, and the savings associated with repair, are difficult to predict other than in obvious instances where duct seams have broken. Building owners/operators may be reticent to invest in these measures given the uncertain economics.

Next Steps for Technology Development

Given the large amount of ductwork in U.S. commercial buildings, duct-leakage diagnostics are an important tool to reduce a well-known source of energy waste. Nevertheless, limited testing has been done on large commercial systems, especially for many different building types and locations.

Table 3-27 presents the potential next steps for duct-leakage diagnostics to gain greater market attention and acceptance.

Table 3-27: Recommended Next Steps for the Development of Duct-Leakage Diagnostics

Initiatives	Lead Organization(s)
Conduct field testing to understand which systems are most prone to leakage and evaluate various tests methods and strategies used to asses leakage losses	DOE, University Research, Industry Organizations,
Develop a standard methodology and test apparatus specifically for commercial buildings	DOE, Manufacturers, Industry Organizations
Offer incentive programs to lower the upfront cost of duct-leakage diagnostics to building operators	DOE, Utilities

References

Roth et al. 2005. “Energy Impact of Commercial Building Controls and Performance Diagnostics: Market Characterization, Energy Impact of Building Faults and Energy Savings Potential. “ TIAX LLC. Reference No. D0180.

Walker et al. 2010. “Air Leakage of Furnaces and Air Handlers.” 2010 ACEEE Summer Study on Energy Efficiency in Buildings. p. 1.330 – 1.345.

Walker et al. 2010. “Residential Forced Air System Cabinet Leakage and Blower Performance.” Lawrence Berkley National Laboratory. March 2010.

Westphalen et al. 2005. "Duct Leakage Fault Detection." ASHRAE Journal. Vol. 47, No. 8, August 2005. p 56-58.

Wray, Craig. 2003. "Duct Thermal Performance Models for Large Commercial Buildings." Lawrence Berkeley National Laboratory. LBNL-53410.

Wray and Sherman. 2010. "Duct Leakage Modeling in EnergyPlus and Analysis of Energy Savings from Implementing SAV with InCITE." Lawrence Berkeley National Laboratory.

Wray et al. 2005. "Rationale for Measuring Duct Leakage Flows in Large Commercial Buildings." Lawrence Berkeley National Laboratory. LBNL-58252.

3.3.4 Ductwork in the Conditioned Space

Brief Description	Placing ductwork within the conditioned space of a building is a construction and retrofit strategy that reduces the impact of air and heat leaks on the system’s efficiency. Ductwork placed outside the building’s thermal and pressure envelopes can lose a large amount of thermal energy through conduction losses and air losses. Cooling and heating equipment often must provide additional output to overcome these losses, or risk under-conditioning the spaces. This strategy mitigates these losses and is a cost-effective strategy to apply to new construction projects.		
Technical Energy-Savings Potential (Quads/year)	Market Readiness	DOE Priority	
0.24 Quads/year	High	Low	

Summary

A typical building HVAC system consists of thousands of field-assembled joints that are susceptible to leakage based on the quality of the materials and the installation. One LBNL study estimated that 9% to 26% of the overall building stock experiences significant leakage, which can result in significant system efficiency losses (Wray, 2005). One potential solution for mitigating the effects of these leaks is to install ductwork in the conditioned space of a building; one study estimates that 16% of buildings have ducts in unconditioned spaces.

By installing ductwork in the conditioned space, the space can recover any air or heat leaks by the system. This greatly mitigates the losses experienced by the system. By reducing inefficiencies in the ducting system, this strategy also allows for cooling equipment to be re-sized, leading to further energy savings.

Installing ducts in the conditioned space is a commercialized strategy. In new construction, designs can be made to accommodate this strategy (at minimal cost); for retrofits, ducts can either be relocated, or the building envelope can be adjusted to include the ductwork. There are a few significant challenges that need addition development: complexity in identification of a building’s thermal and pressure envelopes, and complexity in sealing a previously unsealed space.

Table 3-28 summarizes the characteristics, technical energy-savings potential, and research status of this technology.

Table 3-28: Summary of the Characteristics of Ductwork in the Conditioned Space

Attribute	Value	Comments
Systems Impacted	All cooling and heating ducted systems	
Fuel Type	Electricity and Gas	
Relevant Annual Energy Consumption	2.40 Quads/yr	Consumption from all heating and cooling applications (whole system); gas and electric fuel sources; all building types in all climates; medium retrofit potential means moderate adoption by existing buildings
Technical Energy-Savings Potential	0.24 Quads/yr	Applied to relevant annual energy consumption by assuming energy usage reduction of 10%
Peak Demand Reduction	Medium/Low	Peak demand savings for this technology follow the air-conditioning savings offered
Technical Maturity	Emerging	This building strategy has limited practice, but is not widespread; much more visibility in residential homes
Retrofit Potential	Medium/Low	Potentially difficult to implement, depending on the existing installation
Non-energy Benefits	<ul style="list-style-type: none"> - Improved Indoor Air Quality - Improved Comfort - Lower capital costs for new construction 	
Most Promising Applications	<ul style="list-style-type: none"> - Commercial buildings with ducted systems that are easily integrated into the conditioned space - Commercial buildings with smaller ducted networks 	
Next Steps for Technology	<p>Need development to address challenges in the implementation of this technology, such as:</p> <ul style="list-style-type: none"> - Perform field demonstrations and commissioning to collect data on energy savings - Research and develop efficient methods for determining location and quality of a commercial building's thermal and pressure envelopes - Research and develop cost-effective methods for handling complex duct installations 	

Background

- Duct-Leakage Problem

Commercial buildings that generate cooling and heating usually deliver conditioned air to the building interior through a duct network. These duct networks contain thousands of field-assembled joints that are susceptible to air and heat leakage based on the quality of the materials and the installation (Wray, 2005). Surveys and field studies have demonstrated that a typical

building experiences both air leaks due to holes, and heat leaks due to poorly installed insulation. In addition, leakage losses that occur in unconditioned spaces contribute directly to the inefficiency of the system.

The BAIHP study surveyed 75 homes in the program. It stated that, on average, 56% of the leakage of the return and supply ductwork was to unconditioned spaces. (McIlvaine, 2006)

LBNL’s study noted that, based on surveys of nine different commercial buildings, branch ducts tend to be leakier than main ducts (Wray, 2005). LBNL measured the average duct leakages shown in **Table 3-29** below.

Table 3-29: Typical Leakages in Building Ducts for LBNL Study

Leakage Source	Leakage Value (L/s*m2)
Suggested ASHRAE unsealed leakage	2.5
Average for all main branches	4
Average for all branches	9
Average for systems	13
Range for all systems	0.5 to 41

Source: Wray, 2005

LBNL’s study also measured the ratio of the leakage rate to the overall duct flow rate. The study indicated that 70% (7 of 10) of the buildings experienced high amounts of leakage (9% to 26%), and the remaining buildings experienced less than 5% leakage (Wray, 2005).

The existence of leaks will either cause the building’s conditioning system to underperform, or cause it to exert additional energy to overcome the losses. Scientists at Washington State University noted that a typical residential HVAC design (which included locating supply and return ducts in unconditioned space) resulted in an efficiency loss of 20% in typical installations (as assumed by ICC 2006). Removing the inefficiency through proper insulation and relocation to conditioned spaces could result in 96% network efficiency (Lubliner, 2008).

- *Technology Description*

Several different solutions exist to reduce the losses associated with heat and air leakage from duct networks, but one of the simplest to implement in new construction is to place the ducts within the conditioned space. The practice doesn’t require additional complexity or cost when incorporated into the building’s design, and is considered a best practice for the building industry.

There is ample opportunity for gaining efficiency by installing ducts in conditioned spaces or moving existing ones there. In U.S. buildings, installers often place ducts in ceiling return plenums, which is not conditioned space (Wray, 2005). The CEC noted that 16% of buildings

contained ductwork in unconditioned spaces: 60% were in unconditioned plenums and 40% were outside the building (CEC, 2003).

For retrofit projects, there are several strategies that can be adopted to relocate ducts within the conditioned space. One is to reroute the duct system by building alternate branches. This may require additional ductwork, potential resizing of fans, and sealing and removal of the existing system. A second is to extend the building's pressure and thermal envelope to include the existing duct system. This may require removal of current sealants, insertion of additional moisture and thermal barriers, and commissioning to ensure the building's envelop has been extended.

Figure 3-23 shows that a ductwork system can run either within the conditioned space or outside the conditioned space. There are several advantages for placing them in the conditioned space, as cited in the figure.

FIGURE 1: DUCTS IN UNCONDITIONED SPACES

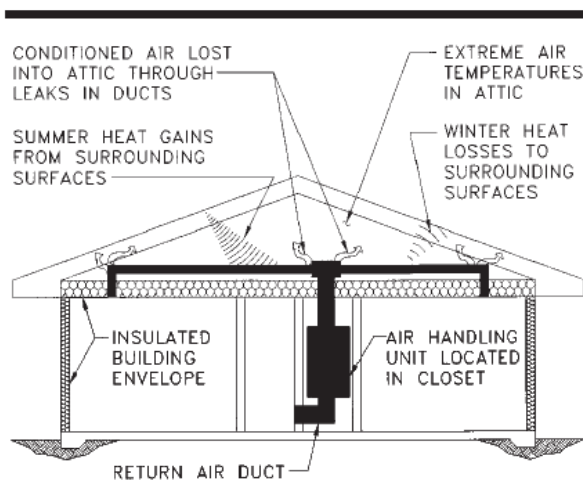

FIGURE 2: DUCTS WITHIN CONDITIONED SPACES

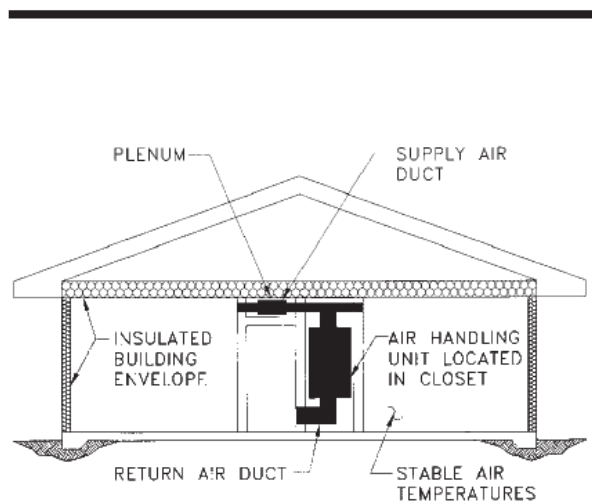

Figure 3-23: Diagram for Two Possible Installations of Ducts

Source: EPA1

- *Energy-Efficiency Advantages*

According to the EPA, air temperatures in unconditioned spaces can fluctuate over a wide range of temperatures, based on the daily outside conditions. For example, air temperatures in an unconditioned residential attic can reach 150° F in the summer, and be close to outdoor conditions in the winter. (EPA, 2000). Extreme temperature result in large heat transfer between the ducts and the surrounding air, resulting in thermal losses for the system. In contrast, a duct located in the conditioned space resides in a controlled environment, which minimizes the thermal conduction losses experienced by the system.

To counteract the thermal losses due to duct leakage, builders often use larger fans and equipment than necessary (Wray, 2005). By placing ducts in the conditioned space, builders can use smaller fan and equipment sizes. This reduces the energy consumption of the system.

- *Peak-Demand Reduction and Other Non-Energy Benefits*

For technologies that can provide air-conditioning, we assumed that savings associated with peak demand would mirror savings associated with overall demand. We assumed that peak demand highly correlates with air-conditioning demand.

The EPA noted that installing ducts in the conditioned space of a building can provide several advantages over a conventional design, including (EPA, 2000):

- Improved comfort
- Improved air quality
- For new construction and extensive retrofits, lower equipment and installation costs due to proper sizing of equipment and ductwork

An LBNL survey also noted the following positive effects that lead to improved air quality (Sigel):

- Reduction of condensation and mold growths on the ducts
- Elimination of pollution by outside air

Energy-Savings Potential

- Potential Market and Retrofit Applications

The strategy of placing ductwork in conditioned spaces can be applied to both new construction and to existing buildings. This strategy will apply to all buildings that contain ductwork systems to transport air.

We assumed that the building stock this technology applies to includes:

- All climate zones
- All building sizes
- All building types
- All cooling and heating applications
- Gas and Electric Applications
- Savings apply to full system energy use

- Energy Savings

Based on an analysis of its potential impact on HVAC systems in the U.S., this technology would save 0.101 Quads of natural gas, and 0.139 Quads of electricity per year.

Some papers have estimated that air and heat leakage from a building's duct network will cause the air to lose 30-40% of its energy before reaching the conditioned space. (Siegel) According to previous studies of commercial buildings cited by LBNL, existing duct leakage and conduction losses in light commercial buildings caused an average drop of 37% in overall cooling efficiency (Wray, 2005). Moving ducts into the conditioned space will almost totally remove these losses.

Cost and Complexity

For new construction, when ductwork is designed to reside in the conditioned space, there is minimal additional cost imparted on the builder. For retrofit projects, there are various methods for transferring ducts to an indoor space, each with its own set of costs.

In residential buildings, one strategy has been to adjust the building's thermal and pressure envelope so that it includes the existing duct. Washington State University estimated that the incremental cost of moving ducts into the conditioned space was -\$31 for a 1344 square foot home, and \$71 for a 2200 square foot home. WSU estimated costs of \$277-\$488 for additional framing and drywall for duct chases, and savings of \$308-\$417 through elimination of R8 duct insulation, shorter duct runs, and reduced labor costs (Lubliner, 2008).

Another strategy is simply to build new ducts that do lay inside the building's thermal and pressure envelope, rerouting conditioned air through this new path. ACEEE estimated (using RS Means 2009) that the total cost of a rectangular steel duct was between \$4.20 and \$10.61 per square foot of serviced floor, with labor costs from \$3.36 to \$6.32 per square foot of serviced floor (Sachs, 2009).

Technical Maturity and Perceived Barriers to Market Adoption

This is a commercial available technology. This strategy is recognized as standard practice by builders such as Habitat for Humanity, New Tradition Homes, and Quadrant Homes (WashU). National organizations such as the Environmental Protection Agency (EPA), American Society of Heating, Refrigerating, and Air-Conditioning Engineers (ASHRAE), the California Energy Commission (CEC), and the National Association of Home Builders (NAHB) have recognized the benefit of producing buildings with ducts in the conditioned space.

One LBNL survey noted the following stakeholder objections to introducing this installation practice in the field: (Siegel)

- Aesthetic objections
- Cost concerns
- Resistance to new designs
- Reverse incentives for installers to install larger ducts and equipment to account for losses (more revenue)

The LBNL survey also noted that there are a few technical challenges that discourage the practice as well (Siegel):

- Complexity of sealing previously unconditioned spaces
- Complexity of determining where the thermal and pressure boundaries of the building are

Next Steps for Technology Development

Construction firms have started integrating the strategy of ducts in conditioned spaces into their building practices (Lubliner, 2008). However, implementation of the practice has lagged in commercial buildings (CEC, 2003). Programs such as ENERGY-STAR Homes and LEED

Certified Buildings have advanced awareness of the advantage of this strategy for new construction; this strategy should also be included in national building standards.

Additional development work is needed to effectively implement this strategy in existing buildings. Research and development to address locating and qualifying a building’s pressure and thermal envelopes, as well as for extending an existing envelope, should be performed to increase the viability of this strategy.

Duct-leakage diagnostic systems were selected as one of the priority technologies for in-depth analysis, and are profiled in Section 0.

Table 3-30 presents the potential next steps for duct-leakage diagnostics to gain greater market attention and acceptance.

Table 3-30: Recommended Next Steps for the Development of Ductwork in the Conditioned Space

Initiatives	Lead Organization(s)
Research and develop methods for enhancing support of existing ductwork	DOE, Manufacturers
Perform field demonstrations and commissioning to collect data on energy savings	DOE, Manufacturers
Research and develop cost-effective methods for handling complex duct installations	DOE, Manufacturers
Research and develop efficient methods for determining location and quality of a commercial building’s thermal and pressure envelopes	Standards Organizations, Industry Organizations
Create financial incentives to implementation through utility incentive programs	Utilities

References

CEC, 2003. “Small HVAC Problems and Potential Savings Reports.” California Energy Commission – Technical Report. October 2003. Prepared by: Architectural Energy Corporation.

EPA, 2000. “Locating Ducts within Conditioned Space – Air Distribution System Improvements.” U.S. EPA. EPA 430-F-97-028. December 2000.

Lublinter, Michael et al. “Moving Ducts Inside: Big Builders, Scientists Find Common Ground.” Washington State University. 2008 ACEEE Summer Study on Energy Efficiency in Buildings.

Mellvaine, J. et al. "Building America Industrialized Housing Partnership (BAIHP)." Final Project Report. University of Central Florida / Florida Solar Energy Center. October 2006. FSEC-CR-1663-06.

Sachs, H., Lin, W. and Lowenberger, A. "Emerging Energy-Saving HVAC Technologies and Practices for the Buildings Sector (2009)." ACEEE. December 2009. Report Number A092.

Siegel, Jeffery and Walker, Ian. "Integrating Ducts into the Conditioned Space: Successes and Challenges." University of Texas at Austin, LBNL.

Wray, C.P., Diamond, R.C., and Sherman, M.H. "Rationale for Measuring Duct Leakage Flows in Large Commercial Buildings." LBNL, Environmental Energy Technologies Division. July 2005. LBNL-58252.

3.3.5 Thermal Displacement Ventilation

Brief Description	Thermal displacement ventilation is a process that supplies conditioned air close to the floor at low velocities. The conditioned space is ventilated through natural convection from the floor to the return near the ceiling. Non-energy benefits include improved air quality and comfort.	
Technical Energy-Savings Potential (Quads/year)	Market Readiness	DOE Priority
0.16 Quads/year	Medium	Medium

Summary

A thermal displacement ventilation (TDV) system utilizes natural convection to ventilate and condition the occupied space in a room. Cooled supply air, which is conditioned to be much warmer than the supply air of a conventional mixed ventilation system, enters the room at or near the floor, and rises as it is warmed by thermal loads (e.g., occupants and electronic devices) in the room toward returns at or near the ceiling. The technology is widely available and adopted in Europe, but its presence in the US market is extremely limited. The technology would benefit from further demonstrations to determine how the costs and benefits of TDV would translate to various climates and building characteristics in the U.S.

Table 3-31 summarizes TDV.

Table 3-31: Summary of the Characteristics of Thermal Displacement Ventilation

Attribute	Value	Comments
Systems Impacted	Ducted cooling system	
Fuel Type	Electricity	
Relevant Annual Energy Consumption	1.71 Quads	50% of all annual electric cooling energy consumption.
Technical Energy-Savings Potential	0.17 Quads	~10% system energy savings.
Peak-Demand Reduction	Medium	Reduction in peak demand varies with climate, but is generally modest.
Technical Maturity	Commercially available	Available mostly in Europe; limited presence in the US market.
Retrofit Potential	Medium	Requires ductwork replacement in addition to new cooling system that provides low-velocity air at necessary flow rate.
Non-energy Benefits	<ul style="list-style-type: none"> - Improved indoor air quality - Reduced noise - Reduced refrigerant use 	
Most Promising Applications	Commercial buildings with moderate heating and cooling loads. Building having large open areas with tall ceilings (9+ ft.) would be most ideal.	
Next Steps for Technology	<ul style="list-style-type: none"> - Evaluate the performance of TDV in the U.S. (cost, energy savings, indoor air quality) through field demonstrations - Develop more accurate load calculation and modeling approach to improve cooling load estimate associated with the use of TDV system in buildings - Develop design options for TDV that include space heating capabilities 	

Background

- Technology Description

When cooled air enters a space, it rises to the ceiling as it warms due to thermal buoyancy. Thermal displacement ventilation (TVD) uses this concept by supplying conditioned air (or cool outside air) close to the floor, and exhausting warm, stale air at the ceiling. With a TVD system, the fresh air is conditioned at a temperature slightly lower than the desired room temperature, which is much warmer compared to supply air for a conventional air-conditioning system. This supply air is delivered horizontally at or near the floor and spreads across the room. TDV system creates two temperature zones within a room: a cooler, stratified occupied zone and a warmer, mixed-upper room zone. Natural convection carries the air upward towards the ceiling as it warms and out through the returns at or near the ceiling instead of mixing stale air with ventilation air (**Figure 3-24**). This vertical airflow increases indoor air quality by displacing airborne pollutants out of the conditioned zone without mixing in the conditioned zone. It also provides improved space comfort to the occupants, assuming that the ceiling is sufficiently high.

When designed correctly, TDV can reduce the need for standard air-conditioning by using low outdoor air temperatures as low-energy cooling.

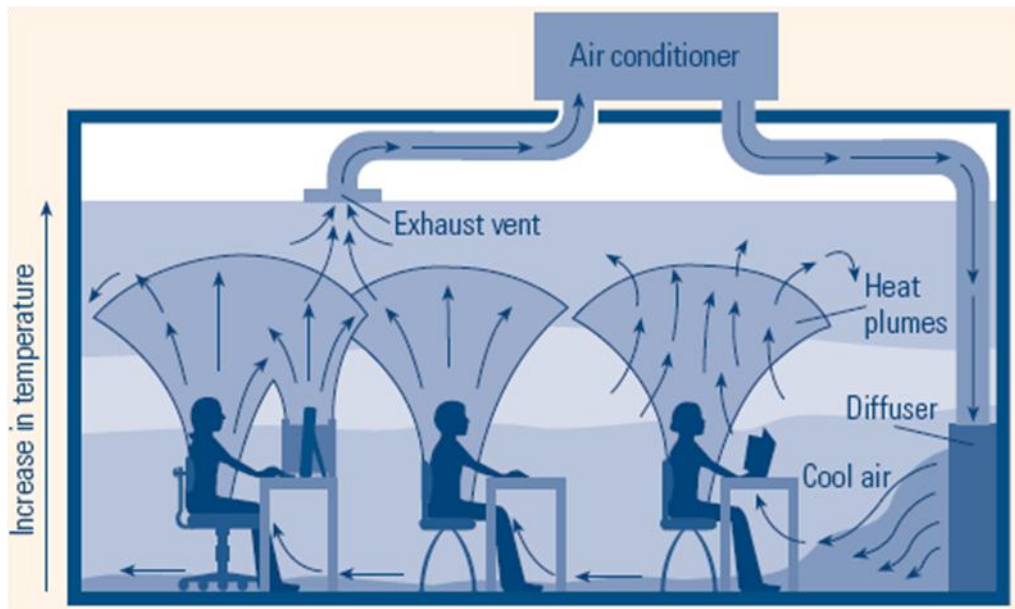

Figure 3-24: Typical Airflow Pattern of a Thermal Displacement Ventilation System

Source: CEC (2008)

- *Energy-Efficiency Advantages*

TDV reduces air-conditioning energy consumptions in several different ways:

1. The higher supply air temperature reduces the temperature lift across the compressor, thereby improving the system efficiency when compared to a conventional air-conditioning system. For a TDV demonstration at an elementary school in California, Eley and Arent (2006) report that the supply-air temperature was set at 65°F, an increase of 10°F compared to a standard packaged unit with a mixed ventilation system.
2. Since TDV systems create two temperature zones within a room, the stratified air results in a higher average temperature across the conditioned space than a room cooled with mixed ventilation. This in turn reduces heat loss through the envelope.
3. In dry, temperate climates, the higher supply-air temperature may enable more frequent use of an economizer. When the ambient air temperature allows unconditioned outside air to be directly introduced into the building as supply air, it reduces the need for mechanical cooling.

Energy-Savings Potential

- *Potential Market and Retrofit Applications*

TDV has been widely used in Europe since the 1970s, but does not have strong presence in the US market to this day. In the US, TDVs are typically used in industrial facilities and data centers. However, TDVs are best suited to condition large, open areas with 9- to 12-foot ceilings that require moderate heating and cooling loads. These spaces would be able to accommodate the necessary diffusers and allow for buffer zones to avoid potential thermal discomfort.

Nonetheless, the technology is widely applicable to almost any type of building that accepts a

conventional, overhead forced-air distribution system, most of which have ceiling height of 9 feet or greater. In Europe, for instance, TDV is used in libraries, auditoriums and casinos, as well as other open space such as lobbies and atriums.

However, this technology requires significant effort to be implemented as a retrofit solution; a retrofit installation of TDV would typically require restructuring of ductwork, replacement of supply and return fans, and upgrading of controls. In estimating the applicable annual primary energy consumption, we assume that TDV is applicable to approximately 50% of U.S. commercial building stock across virtually all types of buildings. Given these considerations, we estimate the relevant annual primary energy consumption for this technology to be 1.71 Quads.

- *Energy Savings*

Arent, et al. (2006) monitored two TDV installations at existing schools in California, one in a hot inland climate and another in a temperate coastal climate.¹³ Both demonstrations were retrofits of existing classrooms featuring nine-foot suspended ceilings with a skylight in the center of the classroom. For control, the investigators monitored in each demonstration an adjacent classroom using a conventional packaged rooftop unit. The investigators monitored energy use in the classroom in the temperate climate. They found that the total energy consumption for demonstration classroom was 21% less than that of control classroom during the nine-month monitoring period (from August through May). According to Eley, et al. (2006), the investigators also found that fan speeds of 50-60% of conventional speeds sufficiently cooled the classroom in the same demonstration, resulting in lower energy use.

In another study, Emmerich and McDowell (2005) collected findings from various TDV simulation studies in the United States for non-industrial applications, as presented in **Table 3-32**.

Table 3-32: Summary of Simulated Energy Savings Associated with Thermal Displacement Ventilation [Emmerich and McDowell (2005)]

Study	Bldg. Type	Range of Total Annual Savings (%)			
		Fan Energy	Cooling Energy	Heating Energy	Total Energy
Bourassa, et al. (2002)	Office	N/A	N/A	N/A	30% – 60%
	Generic Building	N/A	N/A	N/A	38% – 59 %
	Lab	N/A	N/A	N/A	44% – 60%
Roth, et al. (2002)	Office	-25% – -49%	29% – 75%	N/A	N/A
Chen and Glicksman (1999)	Office	-17% – -25%	25% – 70%	11% – 28%	7% – 15%
	Classroom	-6% – -25%	26% – 70%	50% – 66%	6% – 38%
	Workshop	-17% – -32%	25% – 70%	(N/A) – 60%	2% – 12%

¹³ The demonstrations took place in Roseville, CA and San Juan Capistrano, CA, respectively.

Zhivov and Rymkevich (1998)	Restaurant	N/A	13% – 45%	-11% – -39%	-12% – 15%
------------------------------------	-------------------	-----	-----------	-------------	------------

The studies Emmerich and McDowell (2005) cite used differing assumptions. For instance, the Bourassa study focused on California (Oakland, San Diego, Pasadena, and Sacramento), which may explain its high total energy savings compared to other studies given the temperate California climate. The other three studies covered differing sets of five US cities.¹⁴ Also, the Chen study indicates reduced heating energy use, perhaps because the study assumed an aggressive reduction of minimum outdoor-air requirements associated with the improved ventilation effectiveness of TDV.¹⁵

Based on the range of total energy savings reported in the Chen study and Zhivov study, as well as the savings based on the demonstration documented by Eley, et al. (2006), we assume that a TDV system would save approximately 10% of HVAC energy consumption on average across the United States.

Cost, Complexity, and Non-energy Benefits

Currently, there is little reliable documentation on the economics of the TDV system. Similar to its energy-savings performance, a TDV system’s operating costs and peak-demand reduction performance depend heavily on climate, given the nature of the technology. TDV is used in Europe primarily for its IAQ improvements by lifting contaminants away from occupants. Reduced noise and refrigerant use are benefits in certain applications.

According to a cost comparison for a hypothetical eight-classroom school building in a southern California climate [ACE (2005)], a TDV system in new construction adds approximately \$8,000 to the first cost, or approximately \$1/ft² (**Table 3-33**), compared to an overhead mixed-ventilation system.

¹⁴ The Roth study simulated Albuquerque, Chicago, Fort Worth, New York and San Francisco; the Chen study simulated Nashville, New Orleans, Phoenix, Portland, ME and Seattle; the Zhivov study simulated Albuquerque, Miami, Minneapolis, Phoenix and Seattle.

¹⁵ According to Emmerich and McDowell (2005), the Chen study reduced the minimum outdoor air from 10 L/s per person to 7.7 L/s per person for all building types. This is greater than the reduction that would be allowed using the ASHRAE Standard 62.1-2004 default air change effectiveness values.

Table 3-33: Simulated TDV System Cost Comparisons for a Hypothetical Eight-Room School Building in Southern California

Cost Category	Overhead Mixed Ventilation		TDV	
	Packaged VAV RTU	Air-Cooled Chiller and Boiler	Packaged VAV RTU	Air-Cooled Chiller and Boiler
Cooling Equipment^a	\$85,500	\$80,000	\$75,000	\$70,000
Boiler	N/A	\$20,000	N/A	\$20,000
Controls	N/A (standard)		\$10,000	
VAV Terminal Units	\$40,000	N/A	\$40,000	N/A
Fan Coil Units	N/A	\$64,000	N/A	\$64,000
Diffusers/Ductwork	\$24,000	\$24,000	\$32,000	\$32,000
Total Installed Cost	\$149,500	\$188,000	\$157,000	\$196,000
Cost/ft²	\$19,50	\$24,50	\$20.40	\$25.50

a. Cooling equipment size is 30 tons for the overhead mixed ventilation system, and 25 tons for the TDV system.
Source: ACE (2005)

Blatt (2006) notes several factors that could offset the incremental cost of TDV installation, including simplification of ductwork and downsizing of cooling equipment. The latter could also offset the added diffuser and capacity control costs.

Technical Maturity and Perceived Barriers to Market Adoption

This is a commercially available technology. Packaged HVAC system manufacturers such as Carrier are beginning to provide packaged rooftop units that could support TDV strategies.¹⁶ However, most US HVAC designers and contractors are not currently familiar with TDV. While some software tools have built-in system types to directly model TDV, many require the user to make assumptions regarding the stratification of air (i.e., lower occupied zone as conventionally conditioned zone, and upper zone toward the ceiling as return air plenum). Improperly designed TDV systems can result in decreased occupant comfort due to large temperature differences felt across the body.¹⁷

Climate and building loads greatly affect the suitability of TDV, and TDV needs to be evaluated for each application. Because the benefits of TDV vary widely, predicting energy savings is difficult. In fact, we estimated that TDV could reduce HVAC energy consumption by 10% over conventional alternatives in applicable buildings across the entire U.S., but we expect more detailed evaluation of TDV performance would further refine this estimate. Because introduction of a TDV system would likely add system complexity and upfront cost to a HVAC project, especially for existing buildings, uncertainty regarding energy-savings potential makes the cost justification even more challenging.

¹⁶ Based on product information from Carrier, available at <http://www.commercial.carrier.com/>

¹⁷ AEC (2005) reports that ASHRAE Standard 55-2004 recommends a maximum temperature difference between head and foot level of 3.6°F for seated occupants and 5.4°F for standing occupants.

Another barrier is the need for a supplemental heating system. Because TDV systems use natural convection of cool supply air rising to returns near the ceiling, it does not effectively lend itself to providing heated air. This adds to the cost and complexity to the overall HVAC system.

Next Steps for Technology Development

Table 3-34 presents the potential next steps for TDV to gain greater market attention and acceptance.

Table 3-34: Recommended Next Steps for the Development of TDV

Initiatives	Lead Organization(s)
Evaluate the performance of TDV in the U.S. (cost, energy savings, indoor air quality) through field demonstrations	DOE, manufacturers
Develop more accurate load calculation and modeling approach to improve cooling load estimate associated with the use of TDV system in buildings	DOE, manufacturers
Develop design options for TDV that include space heating capabilities	DOE, manufacturers

References

Architectural Energy Corporation (ACE), 2005. “Energy Design Resources Design Brief: Displacement Ventilation”. August. Available at http://www.energydesignresources.com/media/1723/EDR_DesignBriefs_displacementventilation.pdf.

Arent, J., and Eley, C., 2006. “Advanced HVAC Systems for Improving Indoor Environmental Quality and Energy Performance of California K-12 Schools – Project 2 Final Report: Thermal Displacement Ventilation”. California Energy Commission Public Interest Energy Research Program. June. Subtask 2.0d&e deliverable for contract no. 500-03-003.

Blatt, M., 2006. “Advanced HVAC Systems for Improving Indoor Environmental Quality and Energy Performance of California K-12 Schools: Applications Guide for Off-the-Shelf Equipment for Displacement Ventilation Use.” California Energy Commission Public Interest Energy Research Program. May. Subtask 4.2j1 deliverable for contract no. 500-03-003.

Butler, D., 2002. “Air Conditioning Using Displacement Ventilation to Maximise Free Cooling.” CIBSE Conference 2002.

Dickens, K., 2003. “ASHRAE Green Tips.” ASHRAE GreenGuide.

Eley, C., Arent, J., and Meister, B., 2006. “Displacement Ventilation in Action: Performance Monitoring of Demonstration Classrooms.” 2006 ACEEE Summer Study Proceedings.

Emmerich, S. J., and McDowell, T., 2005. "Initial Evaluation of Displacement Ventilation and Dedicated Outdoor Air Systems in Commercial Buildings." National Institute of Standards and Technology. NISTIR 7244.

Lee, K.S., Jiang, Z., and Chen, Q., 2009. "Air Distribution Effectiveness with Stratified Air Distribution Systems." ASHRAE Transactions. Vol. 115, No. 2.

3.4 Performance Optimization & Diagnostics

Technologies in this category monitor, measure, and benchmark HVAC energy consumption and operations to facilitate maintaining optimal performance over the life of equipment. Typical HVAC systems often perform less efficiently than they were designed to perform due to improper installation and startup, degradation of equipment over time, changes in building use, or other factors. Performance Optimization and Diagnostics technologies help to prevent inefficient equipment and systems operation caused by these factors. These technologies do not, by themselves, save energy; rather, they enable energy savings by identifying inefficiencies so that maintenance personnel can make the necessary repairs, replacements, or adjustments. Although some of these technologies are applicable to other building systems (e.g. lighting, building envelope, etc.), the definitions below focus specifically on HVAC systems:

- Retrocommissioning (RCx)
 - RCx restores building performance by investigating, and evaluating HVAC systems and their operations through a systematic process repeated periodically (typically, once every few years).
 - Through a comprehensive examination of existing building HVAC systems, RCx identifies problems associated with equipment deterioration, inadequate maintenance, changing building characteristics, improperly operated controls and other issues that occur after startup commissioning.

- Continuous Commissioning (CC)
 - Unlike other forms of commissioning, CC is an ongoing process that uses embedded sensors and physical inspection to maintain HVAC system efficiency through preventive maintenance and optimizing controls.
 - By periodically comparing building conditions and energy consumption with previous findings, CC identifies potential system faults and directs maintenance to restore efficiency.

- Building Energy Information System (BEIS)
 - Consisting of analysis software, data-collection hardware, and communication systems, BEIS continuously monitors HVAC energy consumption and shares the data across multiple systems and buildings.
 - The BEIS serves as an integrated, data-driven platform that enables other energy-saving strategies and technologies such as preventive maintenance, optimized scheduling, demand response programs, etc.

- Packaged Rooftop Unit FDD
 - While incorporating aspects of the above technologies, packaged rooftop unit FDD systems are highlighted separately because of the unique characteristics of packaged equipment, i.e.
 - Half of all conditioned commercial floor space in the U.S. uses packaged HVAC equipment (Brodrick, 2000)
 - Purchasing cycles are more frequent
 - FDD capabilities are factory-installed on each unit.

- Packaged rooftop unit FDD systems quickly alert building operators when equipment experiences a fault or drop in efficiency by continually comparing embedded sensor measurements to a performance model.

3.4.1 Retrocommissioning

Brief Description	HVAC systems in commercial buildings often operate less efficiently than designed due to equipment deterioration, inadequate maintenance, or improperly operated controls. Retrocommissioning (RCx) restores building performance by investigating, evaluating, and repairing the HVAC system and its operations through a systematic process.	
Technical Energy-Savings Potential (Quads/year)	Market Readiness	DOE Priority
0.87 Quads/year	High	Low

Summary

Retrocommissioning (RCx) can raise HVAC system efficiency for existing buildings by systematically benchmarking poor performance, identifying problem areas, restoring efficient operation, and documenting the associated energy savings. As building operations change, maintenance is deferred, or equipment deteriorates, HVAC system performance can drop and energy consumption can rise. For existing buildings, RCx is a way to improve efficiency so that the building HVAC system operates as designed (or better) by repairing mechanical faults, recalibrating controls, modifying operating set-points, and other actions. For older or HVAC-intensive commercial buildings, RCx has been proven to reduce energy consumption throughout the U.S., often with a favorable payback (Mills, 2009). In addition, RCx can:

- Provide better occupant comfort,
- Improve indoor air quality
- Lower long-term maintenance costs
- Extend equipment life

Increased documentation of successful RCx projects demonstrates their effectiveness, improves the energy-savings estimation, and lowers the upfront financial risk for potential buildings.

Table 3-35 presents a summary overview of retrocommissioning for commercial buildings.

Table 3-35: Summary of the Characteristics of Retrocommissioning

Attribute	Value	Comments
Systems Impacted	Essentially all building HVAC systems	Impact will vary according to how well the building has been maintained
Fuel Type	Electricity and Gas	
Relevant Annual Energy Consumption	6.69 Quads/yr	
Technical Energy-Savings Potential	0.87 Quads/yr	
Peak Demand Reduction	Varies	Certain projects can significantly reduce peak demand
Technical Maturity	Commercially Available	
Retrofit Potential	High	
Non-energy Benefits	<ul style="list-style-type: none"> - Extends equipment lifetime - Improved IAQ - Better occupant comfort 	
Most Promising Applications	Buildings that would benefit most: <ul style="list-style-type: none"> - Buildings that did not undergo initial commissioning - Older buildings - HVAC intensive buildings 	
Next Steps for Technology	<ul style="list-style-type: none"> - Creating a database of successful RCx projects - Offer incentive programs to building operators 	

Background

- Technology Description

Commercial HVAC consists of many complicated and interconnected systems working to provide space conditioning to occupants. Over time these systems deviate from optimum performance levels and often go unnoticed as energy costs significantly rise. For existing buildings, retro-commissioning (RCx) is a way to improve efficiency so that the building HVAC system operates as designed (or better). The RCx process investigates the operations of the various electrical, mechanical, and control components to determine how the integrated HVAC systems function in that building. When performed correctly, RCx unveils significant causes of poor energy efficiency so they may be remediated.

Generally, performing RCx involves planning, investigation, implementation, and verification of building energy usage in a systematic and quantitative manner. This process differs for each specific building application and budget but follows a common procedure (Amarnani et al., 2007, [2]):

1. Benchmarking – To understand where inefficient HVAC operation occurs, building models determine how the building should be functioning. Based on the building type, layout, purpose, schedule, location, and any other underlying conditions, software programs can calculate the expected HVAC energy usage. For newer buildings, architects and designers may have completed this step before construction. Comparing the building-

specific data to data for similar building in geographically similar locations offers another way to determine the extent of any anomalies.

2. Planning – Once benchmarking is complete, the RCx team can develop a strategy to isolate and address performance issues. Preliminary walkthroughs and discussions with building staff increases understanding of the specific HVAC equipment and systems. This initial audit also identifies obvious inefficiencies or points that require further study. Upon completion of the initial audit, the RCx team develops a project scope and goals to accomplish during the RCx process.
3. Investigation – This phase determines the causes of inefficient HVAC operation. Detailed measurement and examination of equipment, control algorithms, temperature set-points, operation schedules, etc. reveal where potential solutions could improve HVAC efficiency. This can include installing monitoring or fault detection and diagnostic sensors to provide actual data. The RCx team completes a detailed plan of the steps needed to bring the HVAC systems to peak efficiency.
4. Correction of Deficiencies – The RCx team resolves the problems uncovered during the investigation phase relating to poor operational efficiency. This includes replacement, repair, reconfiguration or replacement of existing systems and equipment to deliver optimal efficiency. Some of the most common solutions include adjusting set-points, modifying the sequence of operations, improving scheduling, calibration of sensors/equipment and mechanical repair to system components (Mills and Mathews, 2009).
5. Implementation - If the building requires new equipment or systems to operate efficiently, they are installed after optimization of existing systems. For many buildings, this would include installing a building energy management system permanently or upgrading to new high-efficiency equipment.
6. Performance Testing – After the building receives the necessary upgrades, the RCx team evaluates the HVAC system performance to ensure that the system operates as expected.
7. Training and Documentation – The RCx team documents any work performed during RCx, including change of equipment or operations to serve as a resource to building staff. The RCx team then arranges for staff training on how to operate and maintain equipment so that it continues to operate efficiently.
8. Evaluation – For some time after all improvements are made, the building is monitored again. To determine the effectiveness and savings attributed to RCx, as well as provide a new baseline for future energy benchmarking.

- *Energy-Efficiency Advantages*

RCx can be an important strategy to understand how a commercial building uses energy and to reduce that usage through implementing a series of improvements. This process saves energy by locating specific equipment or systems not functioning properly and improving their energy

usage. HVAC problems can go undetected unless comfort complaints or spiking energy bills lead maintenance staff to investigate. The underlying problems associated with inefficient system performance can be uncovered through RCx.

- *Peak Demand Reduction and Other Non-Energy Benefits*

Many types of HVAC performance problems have disproportional impacts on energy use during hot periods, when the grid is likely to be stressed. Repairing/replacing equipment to operate properly can have a significant demand benefit beyond that associated with reduced energy use alone, but this will vary for each building.

Other non-energy benefits may include extended equipment lifetimes, lower maintenance costs in the long term, better occupant comfort, and improved indoor air quality. Replacement equipment can sometimes be downsized due to the elimination of systemic losses or other insights found during RCx. This can help lower the total cost of the RCx project.

Energy-Savings Potential

- *Potential Market and Retrofit Applications*

Many existing commercial buildings could benefit from the RCx process. RCx differs from initial building commissioning because it takes place long after the building was first occupied. RCx identifies problems in existing buildings associated with changing building characteristics, equipment deterioration, and other issues that occur long after during startup commissioning. With the vast majority of the U.S. commercial building stock over 5 years old, RCx has the potential to have a significant impact on many types of buildings because the prevalence of poor maintenance practices¹⁸. **Table 3-25** summarizes the cost and economics for selected commissioning projects for various existing building types.

¹⁸ We chose to conduct a preliminary analysis on regular maintenance, as it was one of the technology options selected through our survey. A short description of this technology can be found in Appendix B.

Table 3-25: Summary of RCx Projects (Mills, 2009)

Building Type	Location	# of Sites / Floor Area (Msf)	Energy Savings	RCx Costs (\$/sq.ft.)	Payback Time (years)
Local Government Buildings	California	11 / 1.5	14.3% source energy (11% electricity, 34% gas)	1.01	3.50
Offices and Hotels	New York	6 / 6	10% peak	0.34	2.00
Offices	Connecticut	5 / 2	8.5% electricity	-	0.50
Class-A Offices	Connecticut	3 / 1.2	7.3% electricity	0.62	1.37
Mixed Commercial	Colorado	27 / 10	7% electricity (4.2% peak)	0.19	1.51
Offices and Hospital	Colorado	4 / 1.8	6% peak	0.03	0.38
University Buildings	California	26 / 3.4	10% source energy (4% peak)	1.00	2.50
Elementary School	Michigan	4	-	0.38	2.50
Supermarkets	California	10 / .5	12.1% electricity	0.14	0.25
Mixed Commercial	Northwest U.S.	8	-	0.22	3.20
Mixed Commercial	Oregon	76	10-15% electricity	0.18	1.24
Mixed Commercial and Educational	California	-	1.7-8.1% electricity	0.40	3.00
Total or Simple Average Values	-	186 Msf	~10-15% (7% peak)	0.41	1.8

Source: Mills, 2009

As seen in **Figure 3-10**, the energy-savings impact of RCx varies by building types and is difficult to predict without an analysis of the specific building. Older or HVAC-intensive buildings offer the most opportunity for savings. Buildings that did not undergo initial commissioning are also good candidates for RCx.

- *Energy Savings*

Based on an analysis of its potential impact on HVAC systems in the U.S., this technology would save 0.26 Quads of natural gas, and 0.61 Quads of electricity per year.

Brambley and Katipamula (2005) found that RCx provides savings of 10-30% depending on the particular building. They found that RCx can eliminate losses associated with incorrectly

installed controls and equipment, inefficient scheduling or set-points, and malfunctioning sensors.

Mills and Mathew (2009) reported that 65% of California university system buildings surveyed experienced HVAC issues. They found that RCx saved 10% on HVAC source energy, 9% on electrical usage, and 4% on peak demand.

Mills (2009) analyzed the RCx database compiled at Lawrence Berkley National Laboratory. He found whole building average energy savings of 16% for buildings of various types across the U.S.

Cost and Complexity

The Oregon Department of Energy (2004) performed RCx on a recently built high school in which the HVAC system consumed much more energy than predicted. After investigating and fixing the problems during RCx, they saved \$0.172/sq.ft. at a cost of \$0.876/sq.ft. in the first year. They estimated payback to be around 5 years.

Amarnani et al. (2007, [1]) developed an RCx procedure for public buildings in Los Angeles. The RCx projects realized first year savings of \$0.35/sq.ft. and \$0.18/sq.ft. for electricity and gas respectively at a cost of \$1.27/sq.ft. Estimated payback for these projects was around 3 years.

Mills and Mathew (2009) found that RCx projects have a median yearly savings of \$0.25/sq.ft. at a cost of \$1/sq.ft.

Technical Maturity and Perceived Barriers to Market Adoption

RCx is a commercial available technology although few commercial buildings undergo RCx in the U.S. today. First cost is the primary barrier to this type of building strategy, even though RCx projects have shown to have reasonable paybacks. The pressure to keep first cost down sometimes decreases the effectiveness of the RCx process. Limiting the amount of investigation and remediation during RCx means that many problems can be missed, diminishing its usefulness.

Building owners rarely include commissioning and often budget inadequately for preventive maintenance. Because HVAC system efficiencies cannot be predicted easily without thorough analysis, building owners may be reluctant to invest in RCx when the benefits cannot be known in advance. The lower price of modeling and monitoring equipment in recent years helps lower the upfront costs.

Next Steps for Technology Development

Table 3-36 presents the potential next steps for RCx to gain greater market attention and acceptance.

Table 3-36: Recommended Next Steps for the Development of Retrocommissioning

Initiatives	Lead Organization(s)
Creating a database of successful RCx projects from a wide variety of buildings to improve the accuracy of savings estimates	DOE, Industry Organizations
Offer incentive programs to lower the upfront cost of RCx to building operators	DOE, Utilities

References

[1] Amarnani et al. 2007. “Post-retrocommissioning HVAC Operations Monitoring Using Enterprise-wide Energy Management System.” International Conference for Enhanced Building Operations. November 1-2, 2007.

[2] Amarnani et al. 2007. “Retro-commissioning (RCx) Sustainable Savings: Are We There Yet?” National Conference on Building Commissioning: May 2-4, 2007.

Brambley and Katipamula. 2005. “Beyond Commissioning: The Role of Automation.” Automated Buildings. February 2005. Prepared for the U.S. Department of Energy under Contract DE-AC05-76RL01830

Jacobs, Pete. 2003. “Small HVAC Problems and Potential Savings Reports.” Prepared for California Energy Commission. P500-03-082-A-25.

Mills, Evan. 2009. “Building Commissioning – A Golden Opportunity for Reducing Energy Costs and Greenhouse Gas Emissions.” Prepared for California Energy Commission Public Interest Energy Research (PIER).

Mills and Mathew. 2009. “Monitoring-Based Commissioning: Benchmarking Analysis of 24 UC/CSU/IOU Projects.” Report Prepared for: California Energy Commission Public Interest Energy Research (PIER) Technology Demonstration Program.

Oregon Department of Energy. 2004. “Case Study: Retrocommissioning – Silver Falls School District Gets What It Paid For.” Retrieved from www.energy.state.or.us. January 2004.

3.4.2 Continuous Commissioning

Brief Description	Continuous commissioning (CC) is a periodic process that collects data from building HVAC systems, compares with previous operational data, and reports where dropping performance occurs. By evaluating the actual building conditions and energy consumption over time, CC detects system faults and directs maintenance to restore efficiency.	
Technical Energy-Savings Potential (Quads/year)	Market Readiness	DOE Priority
1.11 Quads/year	High	Medium

Summary

Continuous commissioning (CC) uses embedded measurement devices monitoring HVAC system parameters to monitor efficiency and performance in commercial buildings. Unlike other commissioning processes, CC investigates, identifies, and resolves problems associated with poor HVAC system performance through periodic measurements during the operating life of the building. By periodically monitoring actual building HVAC data, CC can detect changes in energy consumption and performance, and communicate the need for directed maintenance. Suitable for both new construction and retrofit projects, CC reduces HVAC energy consumption throughout building life even after initial commissioning. Wireless sensors, system automation, and integration with other building management systems will lower the cost of implementing CC. Lowering initial costs and showcasing successful projects should expand the practice of CC to maintain performance and lower HVAC energy use in commercial buildings.

Table 3-37 presents a summary overview of continuous commissioning for commercial buildings.

Table 3-37: Summary of Continuous Commissioning Characteristics

Attribute	Value	Comments
Systems Impacted	Essentially all building HVAC systems	
Fuel Type	Electricity and Gas	
Relevant Annual Energy Consumption	6.69 Quads/yr	
Technical Energy-Savings Potential	1.11 Quads/yr	
Peak Demand Reduction	Varies	
Technical Maturity	Commercially Available	
Retrofit Potential	High	
Non-energy Benefits	<ul style="list-style-type: none"> - Extends equipment lifetime - Improved IAQ - Better occupant comfort 	
Most Promising Applications	<ul style="list-style-type: none"> - New construction - Buildings that did not undergo initial commissioning - Older buildings - Energy intensive buildings 	
Next Steps for Technology	<ul style="list-style-type: none"> - Integration with existing building management systems - Develop CC algorithms that minimize the number of sensors - Promote FDD capabilities in product offerings - Creating a database of successful CC projects - Incentive programs for building operators 	

Background

- Technology Description

Continuous commissioning (CC) can help maximize energy efficiency and ensure proper system performance of building HVAC systems throughout their operating life. Like other forms of commissioning, CC involves planning, measurement, identification, analysis and remediation, but unlike other forms of commissioning, CC is an ongoing process. Sensors embedded in the HVAC system automatically measure system performance, and relay the information to a centralized monitoring system. Collecting information periodically allows for performance comparisons over time. Building usage, operations, and scheduling change over time, and CC is able to monitor building performance as currently configured. Building operators can compare the performance of the HVAC system to a periodically refined baseline model. This ongoing benchmarking permits mapping actual performance to changing building usage patterns and configurations to better maintain peak system performance under all building usage scenarios.

Although each CC project differs based on the building needs, each follows a general process:

1. Initial Building Assessment – Before a CC system can be installed, a thorough review of the current building practices, control systems, and major equipment is necessary to understand each aspect of the building’s HVAC energy usage. This includes building walkthroughs, feedback from building staff and occupants, and collecting records of HVAC maintenance or purchases to identify potential problem areas.
2. Baseline Modeling – Although CC will refine HVAC system energy benchmarks based on actual building performance, it is important to understand the differences between the current operational configuration and the original design. Revealing these changes and their impact to HVAC energy use creates baseline data for future benchmarking and an accurate goal for the CC project.
3. Implementation Planning –The CC team builds a detailed plan to implement a CC system once they have a better understanding of the particular building needs and a performance target. This includes project scope, initial costs, and potential savings. Although actual improvements or repairs will not be known until after implementation begins, details found during the initial building assessment and baseline modeling can lead to recommended actions.
4. Installing CC System – Retrofitting a CC system into a building allows for ongoing monitoring of HVAC system parameters. Once installed, the sensors, controls, and centralized computer begin to collect the necessary data to understand the actual building operations and HVAC usage. Comparing this data to the baseline data helps reveal the deficiencies, if any, of the current system configuration. Over time, the CC team develops recommendations and implements repairs or modifications based on the collected data. After these repairs or modifications, the CC system data will help define the new performance baseline.
5. Documentation and Training – As with any commissioning project, each upgrade or observation should be well documented to serve as reference for future maintenance. By training building staff on the benefits, capabilities, and operations of the new CC system, the solutions implemented during the first round of system improvements can be maintained over time. The CC system provides benefit only if the staff understands the collected data and how to use it effectively.
6. Continued Evaluation – CC is a periodic process designed to adapt to changing building parameters. The benchmark of system efficiency will change as well. The periodic reports on HVAC system status that CC delivers to building staff provide the information needed to identify problem areas and maintain system performance.

By measuring key parameters at regular intervals throughout HVAC system operations, building managers understand the status of building systems and can identify any issues easily. A computerized network compares the information gathered by sensors to the baseline model. When a system condition exceeds a predetermined threshold, the CC system provides an alert and a possible cause of the issue. This fault detection and diagnostic (FDD) capability of CC is another feature that separates this process from other commissioning projects. Automation of

measurements and reporting contribute to the success of CC for HVAC systems. Regularly reporting data and potential faults reveals performance trends and any deterioration that may lead to larger issues. Maintenance staff can monitor issues and repair problems as they are reported.

Table 3-38 lists the key technologies required for automated CC.

Table 3-38: Automated Continuous Commissioning Technologies

Technology	Application
Wireless sensing, data acquisition and control	<ul style="list-style-type: none"> - Cost effective sensing and data collection, - Condition monitoring
Plug-and-play building equipment and controls	<ul style="list-style-type: none"> - Self-identifying equipment and automatic system design recognition - Rapid automatic self-configuration of controls
Embedded network sensing and processing	<ul style="list-style-type: none"> - Highly distributed processing of information with local control capabilities coordinated to meet HVAC performance objectives
Automated fault detection, diagnostics, and prognostics	<ul style="list-style-type: none"> - Automatic detection and diagnosis of operation, equipment, and control faults - Anticipation of system and equipment degradation based on historical trends - Automatic generation of maintenance plans - Condition-based maintenance, which can save costs compared to time-based maintenance
Automated proactive testing	<ul style="list-style-type: none"> - Automated startup and functional tests, analysis of data, and interpretation of results - Periodic automated monitoring and testing
Automatic records management and data exchange protocols	<ul style="list-style-type: none"> - Automatic generation of plans and reports - Automatic storage of data
Source: Brambley and Katipamula, 2005	

These advanced components increase the level of automation and ease of implementing CC into building HVAC systems. Wireless technology eliminates the need for wired connections to each sensor, reducing the installation cost and allowing for more sensors. Plug and play systems self-configure to the CC network and report if they experience a loss of functionality, increasing reliability and lowering initial costs. Automatic FDD and reporting capabilities increase the quality of information reported to building operators to effectively identify problem areas in need of attention. Without automatic FDD and reporting, information generated by the CC system may prove to be an inconvenient burden for maintenance staff having a limited budget. Automated monitoring and reporting for CC ensures that building operators have the information needed to identify and address those areas which need maintenance.

- *Energy-Efficiency Advantages*

All types of commissioning include inspections of HVAC system operation and equipment condition to identify suboptimal energy efficiency. CC finds issues as they happen to better maintain system performance and extend equipment lifetimes. Performed on a periodic basis, CC traces trends in equipment function that may eventually lead to higher energy consumption and failure. Gathering increased information by allowing building-management teams to optimize system performance and efficiency can result in energy savings.

- *Peak Demand Reduction and Other Non-Energy Benefits*

Peak demand reductions will depend on the specific building HVAC system, and the steps taken to improve efficiency during CC (especially for air-conditioning). Other potential benefits include extended equipment lifetimes, better occupant comfort, and improved indoor air quality.

Energy-Savings Potential

- *Potential Market and Retrofit Applications*

Most buildings over 50,000 sq.ft. could benefit from the CC process (Deng, 2009). Whether for new construction or retrofit, a CC project integrates conventional HVAC equipment and controls to constantly monitor performance deterioration. Although savings will vary depending on building type, usage, and maintenance resources, CC at the very least provides FDD capabilities to alert of a component failure, so it may be replaced. Like other forms of commissioning, older and energy-intensive buildings benefit most from CC. New construction or buildings that did not undergo initial commissioning could use CC to optimize their operations as well.

- *Energy Savings*

Based on an analysis of its potential impact on HVAC systems in the U.S., this technology would save 0.337 Quads of natural gas, and 0.778 Quads of electricity per year.

Jagermar and Olsson (2007) investigated CC as a part of a high-efficiency-building certification program. They found that CC reduces energy costs by 5-30% for non-residential buildings in Europe.

McCown (2009) found that CC saved a LEED-EB Gold high-performance office building an additional 10% after post-construction commissioning. Through CC, the building staff became more comfortable with the advanced HVAC systems and better maintained performance by recognizing indicators of poor efficiency.

Liu et al. (2005) realized electricity and gas savings of 33% and 44%, respectively, in 7 office and educational buildings using a CC process they developed. CC identified the need for replacement equipment and optimized chilled water, airflow, and zonal controls.

Cost and Complexity

The cost of CC system depends on the project scope and complexity of particular building systems and savings depend on the frequency and nature of identified performance issues. Because of this, it is difficult to estimate the costs and payback of CC. Older and energy-intensive buildings would have more favorable paybacks. Designed to operate for the life of the building, CC generates savings over a long time period, typically over many equipment purchase

cycles. By optimizing system performance, building operators can often downsize to less expensive replacement equipment. As CC monitors system performance trends, maintenance directed by CC reduces costly equipment failure.

Song et al. (2009) found that most CC projects have a cost of \$0.50-1.00/sq.ft. with an average payback of 2 years.

Liu et al. (2002) compiled a list of CC projects across a number of building types. **Table 3-39** presents their findings on the economics of continuous commissioning.

Table 3-39: Economics of CC Projects by Building Type [Liu et al. 2002]

Building Type	Number of Buildings	Savings (\$/sq.ft./yr)	Costs (\$/sq.ft./yr)	Average Payback (years)
Hospitals	6	0.43	0.47	1.1
Laboratory/ Offices	7	1.26	0.37	0.3
Classroom/ Offices	5	0.43	0.23	0.5
Office	8	0.22	0.33	1.5
Schools	2	0.17	0.34	2.0
Averages/ Total	28	0.54	0.36	0.7

Bynum et al. (2008) analyzed the cost-effectiveness of CC for various building types. **Table 3-40** summarizes the findings of their building survey.

Table 3-40: Cost-effectiveness of CC for Various Building Types [Bynum et al. (2008)]

Building Type	Average Savings %	Average Savings (\$/sq.ft.)	Average Cost (\$/sq.ft.)	Average Payback (years)
Education	8.71	0.30	0.33	2.39
Healthcare	14.87	0.38	0.42	1.45
Laboratory	30.38	1.01	0.60	0.77
Office	18.66	0.51	0.48	1.64
Other	8.86	0.17	0.20	0.56

Note: All buildings did not report all metrics. Averages are for buildings that provided data for that metric.

Technical Maturity and Perceived Barriers to Market Adoption

CC is a commercially available technology, but few buildings currently utilize CC capabilities. CC requires both time and capital to install monitoring equipment, analyze data, and resolve problems. Many building maintenance teams are understaffed without the necessary resources to implement effective CC. The upfront cost and complexity of implementing a CC system can dissuade its application where there are uncertain payback periods.

Next Steps for Technology Development

Table 3-41 presents the potential next steps for CC to gain greater market attention and acceptance.

Table 3-41: Recommended Next Steps for the Development of Continuous Commissioning

Initiatives	Lead Organization(s)
Develop CC software that integrates with existing building management systems reducing installation complexity	DOE, Manufacturers
Optimize the number of sensors to lower installation complexity and upfront cost	DOE, Manufacturers
Create a database of successful CC projects showcasing the benefits and savings of an ongoing HVAC performance evaluation	DOE, Industry Organizations, Utilities
Offer incentive programs to lower the upfront cost of CC to building operators	DOE, Utilities

References

Brambley and Katipamula. 2005. "Beyond Commissioning: The Role of Automation." Automated Buildings. February 2005. Prepared for the U.S. Department of Energy under Contract DE-AC05-76RL01830

Bynum et al. 2008. "The Cost-Effectiveness of Continuous Commissioning Over the Past Ten Years." The 8th International Conference for Enhanced Building Operations. October 2008. ESL-IC-08-10-44.

Deng et al. 2001. "Lessons and Measures Learned from Continuous Commissioning of Central Chilled/Hot Water Systems." Proceedings of the First International Conference for Enhanced Building Operations, July 2001.

Deng, Song. 2009. "Continuous Commissioning (CC) In and Outside the USA." BuildingEQ-Symposium in Berlin, October 1, 2009.

Jagermar and Olsson. 2007. "The EPBD and Continuous Commissioning." Intelligent Energy – Europe. Key Action: SAVE. Agreement No. EIE/06/038/SI2 .448300.

Liu et al. 2002. "Continuous Commissioning Guidebook: Maximizing Building Energy Efficiency and Comfort." Federal Energy Management Program. U.S. Department of Energy. October 2002.

Liu et al. 2005. "Continuous Commissioning Leading Energy Project Process - An Industry Approach." Proceedings of the Fifth International Conference for Enhanced Building Operations, October 2005.

McCown, Paul. 2009. "Continuous Commissioning of a LEED-EB Gold Certified Office Building." The 9th International Conference for Enhanced Building Operations. November 2009.

Tenpenny, John. 2009. "Continuous Commissioning: Low Capital – Large Savings." Canadian Sustainable Buildings. December 2009. Vol. 2. Issue 4. p 8-10.

3.4.3 Building Energy Information Systems

Brief Description	Building Energy Information Systems are suites of technology solutions to store, analyze, and display building energy data acquired through energy performance monitoring.	
Technical Energy-Savings Potential (Quads/year)	Market Readiness	DOE Priority
0.8 Quads/year	High	Medium

Summary

Commercial building Energy Information Systems (EIS) collect, store, analyze and display building energy data to facility managers and other end-users to (among other things) help identify and capture opportunities for energy-efficiency improvements across the building systems. This technology is commercially available today, and past case studies indicate considerable energy and cost savings associated with it. Furthermore, recent advances in information and communication technologies have greatly enhanced the capability of EIS. However, the costs and benefits of EIS are not well documented, mainly because the economics of EIS varies significantly depending on application. The technology would benefit from further studies to analyze the costs and benefits of different EIS functionalities and designs, and to document successful applications.

Table 3-42 summarizes commercial building EIS.

Table 3-42: Summary of the Characteristics of Building Energy Information System

Attribute	Value	Comments
Systems Impacted	All HVAC systems	Will help reduce non-HVAC building energy use (e.g., lighting, refrigeration and water heating) as well.
Fuel Type	Both gas and electricity	
Relevant Annual Energy Consumption	4.0 Quads/yr	All types of HVAC equipment for all U.S. commercial buildings
Technical Energy-Savings Potential	0.8 Quads/yr	Estimate 20% savings across all commercial buildings.
Peak-Demand Reduction	Medium	Could be high if the system is optimized to pursue peak-demand reduction as a main objective
Technical Maturity	Commercially Available	
Retrofit Potential	High	No replacements of HVAC systems required.
Non-Energy Benefits	Improved comfort; reduced maintenance needs	
Most Promising Applications	Any types of commercial buildings, although the payback may be better for larger buildings or campuses	
Next Steps for Technology	<ul style="list-style-type: none"> - Establish the costs and benefits of commercial-building EIS for various applications beyond existing one-off case studies and observations - Continue to investigate effective approaches to implement and operate EIS for different applications - Establish an industry standard on the terminologies and nomenclatures for different EIS features and functionalities 	

Background

- Technology Description

Energy Information Systems (EIS) are suites of technology options that combine software, data-collection hardware, and communication systems that provide energy information to building facilities managers, financial managers, and utilities. Basic elements of EIS for commercial buildings include energy monitoring, energy management linked to controls, demand response (DR), and enterprise energy management applications. In most cases, EIS allows users to access many of the functionalities via the Internet. Key inputs commonly processed by EIS include energy-consumption data, weather data, occupancy, building environment data, and other external data streams such as energy price signals.

As depicted in **Figure 3-26**, there are three hierarchical levels of data handling in a typical EIS. First is data collection at the facility end-use level, represented as “Interval meter” in **Figure 3-26**. Data accepted from these endpoints may include metered electricity, gas and water consumption, and utility billing data. Second is data storage and analysis at a data warehouse within a facility or at a third-party service provider, represented as “EIS Host Server” in **Figure 3-26**. Interval meters upload the collected data to a central server at some frequency, from daily

to real-time. Some EIS may offer some type of manual data-entry functionality that allows users to manually input collected data through a Web-based interface. Finally, the third is data configuration, display and management through some type of Web-based interface. Through this interface, EIS visualizes key building energy information, including daily or aggregated load profiles and demand-response status, and comparisons of current information with historical baselines or different buildings covered by the same system.

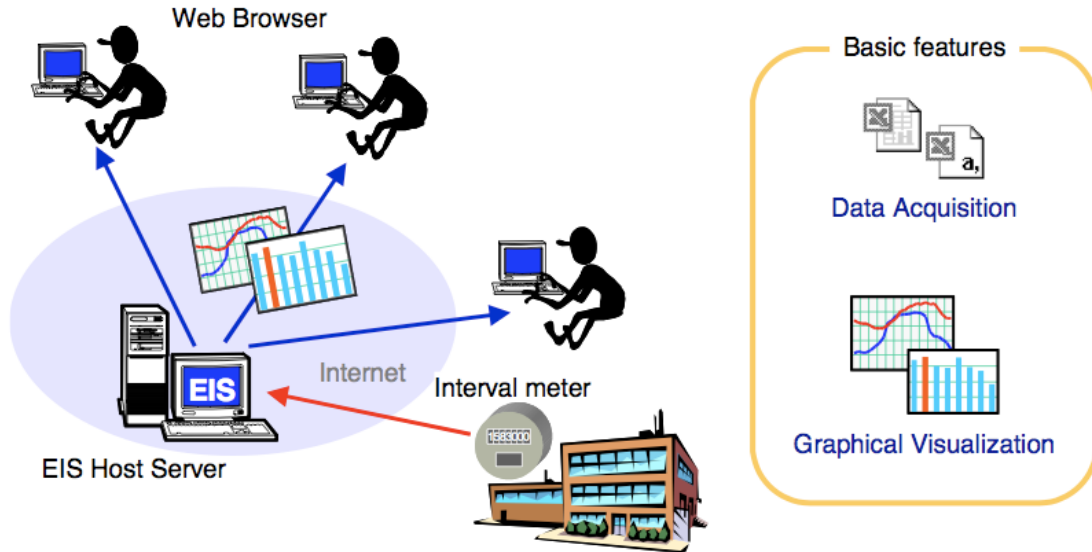

Figure 3-26: Schematic of a Basic Energy Information System

Source: Motegi and Piette (2003) via Granderson, et al. (2009)

Granderson, et al. (2009) developed a framework used to characterize the features of existing commercial building EIS today. **Table 3-43** presents the common functionalities of commercial building EIS by their feature categories.

Table 3-43: Common Features and Functionalities of Commercial Building EIS

Feature Category	Sample Functionalities*
Data Collection, Transmission, Storage and Security	Collection of meter data (e.g., electricity/gas/water consumption, and utility billing); data storage; data archiving
Display and Visualization	Load profiling; demand response (DR) event status display; DR load shedding performance visualization
Energy Analysis	Energy consumptions (e.g., daily/weekly/monthly averages, highs and lows) calculation; load duration calculation; normalization of consumption (e.g., by climate, weather and building size), carbon footprint calculation; energy consumption benchmarking
Advanced Analysis	Forecasting; fault detection and diagnostics; analysis of onsite energy generation (e.g., solar, wind and combined heat and power)
Financial Analysis	Simple energy cost prediction; energy cost analysis (inc. dynamic electricity rates); savings estimation; bill verification and outsourcing
Demand Response	Signal notifications; event response recording; DR setting customization (e.g., manual and automated opt-out, and black-out dates)
Remote Control and Management	General building systems control (through gateways or via the Internet)
<p><i>Source: Granderson, et al. (2009)</i></p> <p>Note: Granderson, et al. (2009) does not identify EIS “functionalities” in their framework. Sample functionalities are identified based on the main features of EIS the investigators use to characterize the capabilities of an EIS.</p>	

Available features and functionalities differ, depending on the intended users or building types.

- *Energy-Efficiency Advantages*

EIS itself does not reduce energy use associated with a building’s HVAC system. However, EIS offers facility managers data, tools and functionalities necessary to identify opportunities for energy savings. As discussed by Granderson, et al. (2011) and Kircher, et al. (2010), a building’s actual energy consumption while occupied tends to be greater than the building’s intended energy performance as initially designed. The energy-use monitoring and data-acquisition capabilities of EIS assist efforts to reduce energy consumption. Aside from non-HVAC-related actions (e.g., elimination of excessive lighting and tune-ups of refrigeration equipment), EIS can facilitate reducing HVAC energy consumption through elimination of excessive ventilation, fault detection and diagnostics, and adjustment of thermostat settings.

Energy-Savings Potential

- *Potential Market and Retrofit Applications*

Commercial building EIS is intended to monitor and analyze energy consumption associated with all aspects of HVAC (i.e., heating, cooling and ventilation), regardless of system type and fuel type, along with other energy usage across a building. The technology is applicable across all climate zones, and building types and sizes. Given these considerations, we estimate the relevant annual primary energy consumption for this technology to be approximately 4 Quads.

- *Energy Savings*

Granderson, et al. (2011) profiles four case studies of EIS performance in three types of commercial buildings: warehouse, retail, and educational facilities. They found that EIS helped facility managers identify potential actions toward greater energy savings, including reduction or elimination of off-hours energy use, and tune-up of refrigeration equipment. The investigators report that these case studies all exhibited some levels of reduction in energy consumption, most in the range of 18% to 30%. Among the energy-savings opportunities identified, the most common faults specific to HVAC include suboptimal scheduling (e.g., running at high capacity during unoccupied hours) and operational faults (e.g., certain components were not functioning properly under certain conditions) [Granderson (2011)]. Based on these considerations, we estimate that an EIS would save approximately 20% of HVAC energy consumption on average across the United States.

Cost, Complexity, and Non-Energy Benefits

Currently, there is little reliable documentation of the economics of commercial building EIS. In addition to enabling facility managers to identify immediate opportunities to reduce energy consumption (e.g. excessive ventilation and lighting), EIS can also enable greenhouse-gas-emissions reduction, peak-demand reduction, maintenance-cost reduction, and economic evaluation of potential future energy-efficiency retrofits.

Technical Maturity and Perceived Barriers to Market Adoption

Commercial Building EIS has been commercially available for over a decade. Recent advances in information technology (e.g., broad availability of mobile access to the Internet) and analytical features have expanded the number of product options that are available (e.g., green-house gas tracking, configurable energy analyses and enhanced interoperability).

However, there is a paucity of good, public information regarding EIS, making it challenging for facility owners and managers to implement and make the best use of EIS. First, the actual costs and benefits of EIS are not well documented. Second, more comprehensive understanding is needed of how EIS solutions are used by facility managers to better characterize the merits of various EIS solutions. Third, the scalability of existing solutions to larger and more complex buildings is not well known. Furthermore, the industry lacks common terminology to describe the features and functionalities of EIS products offered by different vendors.

Next Steps for Technology Development

Table 3-44 presents potential next steps for EIS to gain greater market attention and acceptance.

Table 3-44: Recommended Next Steps for the Development of Building Energy Information System

Initiatives	Lead Organization(s)
Establish the costs and benefits of commercial-building EIS for various applications beyond existing one-off case studies and observations	DOE, advocacy groups
Continue to investigate effective approaches to implement and operate EIS for different applications	DOE, manufacturers
Establish an industry standard on the terminologies and nomenclatures for different EIS features and functionalities	DOE, advocacy groups, manufacturers

References

Granderson, J., Piette, M. A., Ghatikar, G., and Price, P., 2009. “Building Energy Information System: State of Technology and User Case Studies”. Lawrence Berkeley National Laboratory. LBNL-2899E.

Granderson, J., 2011. Personal communication. Telephone interview conducted on July 7.

Granderson, J., Piette, M. A., and Ghatikar, G., 2011. “Building Energy Information System: User Case Studies”. *Energy Efficiency Journal*. Vol. 4, No. 1. February.

Kircher, K., Ghatikar, G., Greenberg, S., Watson, D., Diamond, R., Sartor, D., Federspeil, C., McEachern, A., and Owen, T., 2010. “Toward the Holy Grail of Perfect Information: Lessons Learned Implementing an Energy Information System in a Commercial Building”. Abstract for the presentation at 2010 ACEEE Summer Study on Energy Efficiency in Buildings.

Motegi, N., and Piette, M.A., 2003. “Web-based energy information systems for large commercial buildings”. Lawrence Berkeley National Laboratory. LBNL-49977.

3.4.4 Fault Detection and Diagnostics for Packaged HVAC Equipment

Brief Description	Fault detection and diagnostic (FDD) systems alert building operators of various problems associated with packaged HVAC systems. By identifying performance deviation and determining its cause, directed maintenance can restore the equipment to peak efficiency.	
Technical Energy-Savings Potential (Quads/year)	Market Readiness	DOE Priority
0.08 Quads/year	Medium	Medium

Summary

Packaged rooftop HVAC systems often operate inefficiently due to malfunction or wear on equipment and controls. Although these issues may be found during regular maintenance, fault detection and diagnostic (FDD) systems continually compare the status of the unit to a model, and alert building operators of the presence and cause of faults. Repairing these problems maintains system efficiency and reduces poor operation that would normally go unnoticed. Rooftop HVAC equipment having factory-enabled FDD capabilities would have a favorable payback if the maintenance were performed appropriately upon identifying faults. Field testing of the various FDD methods will reveal the best approaches to situational modeling, alarm detection, and interoperability for development of industry standards. Due to minimal added cost, we expect that FDD systems will be offered widely after further technology development.

Table 3-45 presents a summary overview of FDD for packaged HVAC equipment.

Table 3-45: Summary of FDD for Packaged HVAC Equipment Characteristics

Attribute	Value	Comments
Systems Impacted	Packaged HVAC equipment	
Fuel Type	Electricity and Gas	
Relevant Annual Energy Consumption	0.63 Quads/yr	
Technical Energy-Savings Potential	0.08 Quads/yr	
Peak Demand Reduction	Varies	Maintenance of air-conditioning efficiency has a peak-demand impact
Technical Maturity	Emerging	
Retrofit Potential	High	
Non-energy Benefits	<ul style="list-style-type: none"> - Extends equipment lifetime - Better occupant comfort - Reduced noise 	
Most Promising Applications	<ul style="list-style-type: none"> - High-efficiency packaged rooftop units 	
Next Steps for Technology	<ul style="list-style-type: none"> - Manufacturers incorporate FDD capabilities in their product offerings, especially for the DOE/CBEA “High-Performance Rooftop Air-Conditioning Specification” - Field trials to determine the best configuration of sensors and software for FDD systems - Develop industry standards for fault identification - Offer incentive programs to building operators 	

Background

- Technology Description

Over half of all conditioned floor space in the U.S. incorporates packaged HVAC equipment in their system design (Brodrick, 2000). Packaged HVAC systems come in a variety of sizes to the thermal loads of buildings at relatively low-cost. Building operators often do not incorporate packaged equipment in energy management systems (EMS) or perform regular preventive maintenance as they would for larger custom equipment. Because of this, faults regularly occur in packaged units. Further, the subsequent drop in system efficiency may go unnoticed. If the system produces adequate heating or cooling, building operators or occupants may not recognize a fault without regular inspections of equipment. Typically, visual inspection or cursory maintenance is only regularly performed a few times a year at best, so these faults go unmitigated for long periods of time.

Packaged rooftop units (RTUs) contain multiple system components inside a single enclosure. Any of these subsystems or components could be operating inefficiently at any time. Even when occupants notice poor performance, it is often difficult for technicians to quickly locate the fault’s source. An investigation into the packaged HVAC equipment maintenance issues of California businesses revealed a number of common faults in equipment (Jacobs 2003). **Figure 3-27** demonstrates the frequency of common faults found during the survey.

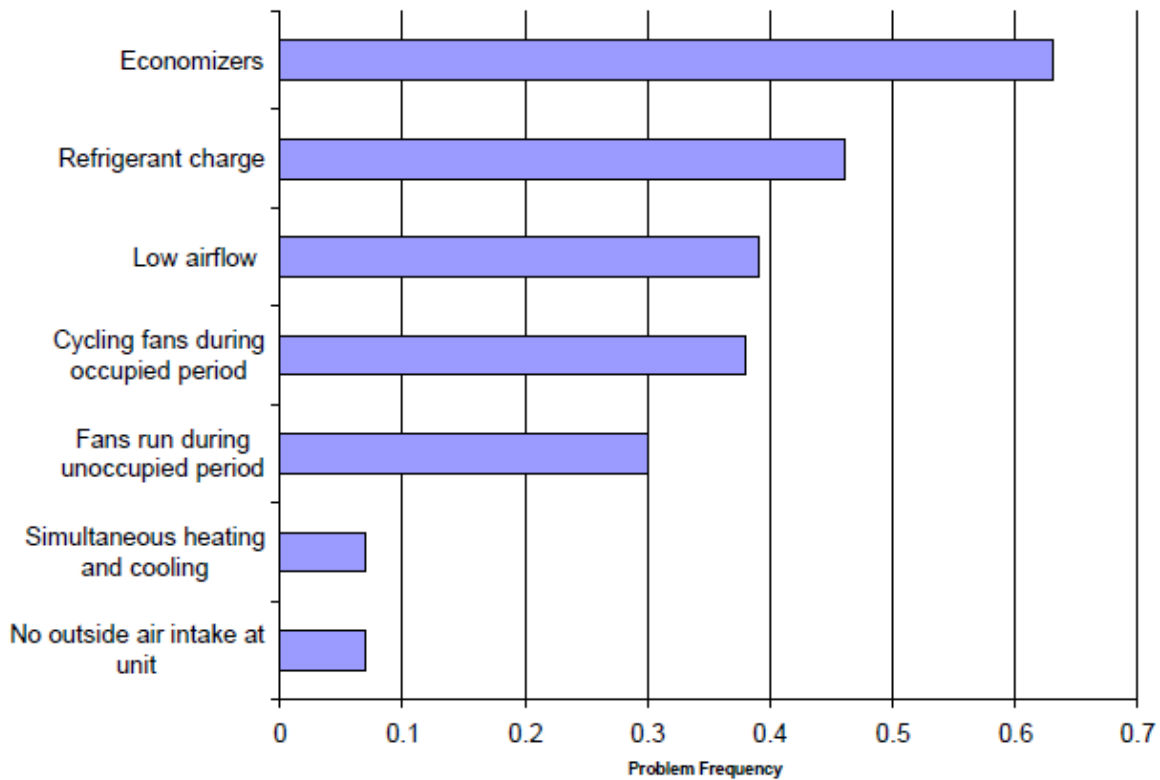

Figure 3-27: Frequency of Common Problems Found in Rooftop HVAC Equipment

Source: Jacobs (2003)

These common faults cause inefficient operation for the packaged system in some of the following ways:

- Economizers provide space cooling when the ambient temperature is sufficiently low by opening a damper and bringing in cool outdoor air. When done correctly, this offsets the need for compressor-driven cooling. A motor opens the damper when various sensors detect suitable ambient conditions. When any of these components fail the damper may remain in a fixed position. If stuck open, warm outdoor air enters the building during cooling mode, or cold air enters during heating mode. If the damper is stuck shut, it may eliminate the building's source of ventilation air.
- Vapor-compression systems rely on the correct refrigerant charge to maintain the designed capacity and performance. Refrigerant leaks can greatly reduce system capacity and efficiency even with advanced expansion and distributor valves. Overcharging strains the entire system and can quickly wear out components causing poor efficiency or failure.
- To properly condition a space, both the evaporator and condenser need sufficient airflow. Capacity and efficiency suffer when the thermal transfer of energy drops with low airflow. Causes include surface fouling, improperly aligned roof curbs, mechanical blockages, and many other sources.

Regular maintenance may reveal these issues. Often, this is only performed on a yearly basis, leaving the possibility of many months of inefficient operation. These faults could be remediated if maintenance technicians were aware of their presence. FDD systems alert building operators when a packaged unit either fails or experiences a drop in efficiency. Various sensors provide data to computational software that then follows an algorithm to measure system performance and provide a fault signal if efficiency deviates. The FDD system can recognize the prevalence of faults in packaged units so building operators can optimize system performance through directed maintenance.

All FDD systems rely on a combination of sensors, control algorithms, benchmarking software and other components. For packaged systems, FDD can discover common faults associated with equipment operation. They measure various system parameters including indoor and outdoor environmental conditions, and compare these against an expected set of outcomes. When these differ, the system knows a fault is present and diagnoses a possible cause through an algorithm checklist. **Figure 3-28** outlines a sample process.

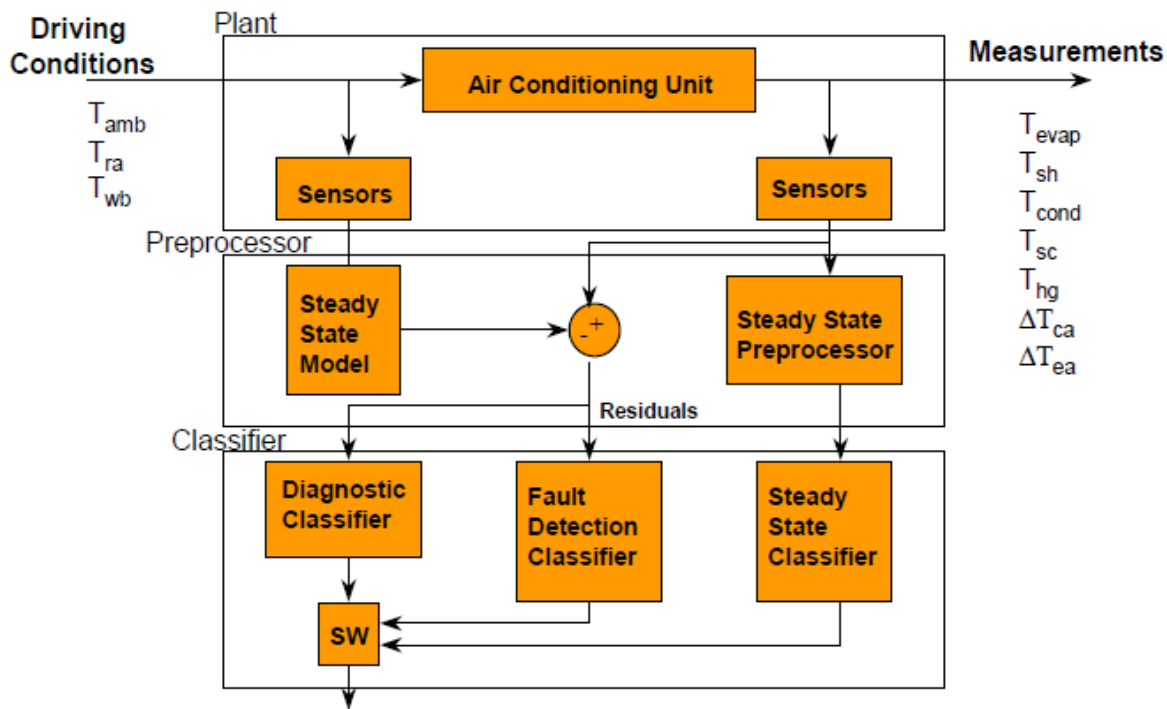

Figure 3-28: Sample FDD Process Chart for Packaged HVAC Equipment

Source: Li and Braun (2003)

The plant consists of the HVAC equipment itself and the sensors that record system conditions and feed data to the processing units. The preprocessing unit features both a steady-state (ss) processor and model. The ss model uses the ambient conditions and system configuration to determine how the equipment ideally would have functioned. The difference between the ideal model and the actual state inputs indicate an irregularity. The fault detection and diagnostic classifiers send the remaining state differences through an algorithm to determine the presence and cause of a true fault. To prevent false positives, the ss preprocessor and classifier determine

whether the system was at a non-ss part of its operating cycle (e.g. start-up). A false positive is avoided by negating the FDD output during non-ss reading. When the difference between the ideal model and actual operation exceeds a threshold, the system determines that a fault has occurred and the diagnostician attempts to determine the cause. The maintenance staff receives the fault information and is therefore better prepared to quickly find a solution.

The nature of FDD systems for packaged units varies greatly from the simple to most complex. Typically, additional sensors produce better data, creating a better model to evaluate system performance, and greater diagnostic capabilities. But many common faults such as clogged filters or low refrigerant charge are found using simple measurements. Non-invasive load monitoring (NILM) systems use voltage and current sensors placed on strategic components to measure the electrical signature during operation. This type of FDD directly recognizes differences in the electrical characteristics, reducing some of the reliability issues found with other sensor types. Wireless sensors can network to a central data receiver and upload the FDD status to technicians through building information networks, reducing installation time. Other less complicated systems may relay a message to a thermostat display that indicates what type of fault has occurred. Many different systems are available to meet the needs of a variety of packaged HVAC units.

- *Energy-Efficiency Advantages*

Often, available maintenance resources do not adequately cover the needs of the building's equipment. FDD reduces the time to find and repair malfunctioning equipment, better leveraging scarce maintenance resources. FDD does not automatically fix problems, but points the service technician to the probable cause of the performance drop in a specific unit. Packaged-unit FDD does not take the place of regular maintenance, but will show the continual efficiency status of certain key components. Furthermore, by providing maintenance when there is a slight malfunction reduces the chance of a larger failure and costly replacement.

- *Peak Demand and Non-Energy Benefits*

Since air conditioning accounts for a large portion of peak demand, any improvements for packaged HVAC units would have a consequential impact on demand. Poorly operating units have lower efficiency, so using FDD systems to maintain optimum performance reduces system demand to near the levels experienced when the equipment was new.

Early detection of problems can prevent a larger equipment failure and extend equipment lifetime if repaired promptly. Packaged systems that operate at their designed performance will often provide better occupant comfort at reduced noise levels. FDD supplements regular maintenance, which has shown to have numerous additional energy and non-energy benefits¹⁹.

Energy-Savings Potential

- *Potential Market and Retrofit Applications*

Packaged heating and cooling equipment will benefit from the addition of FDD through constant evaluation of system performance. Almost all packaged units would benefit from FDD systems and installation is simplified with wireless sensors and receivers. By checking the status of

¹⁹ We chose to conduct a preliminary analysis on regular maintenance, as it was one of the technology options selected through our survey. A short description of this technology can be found in Appendix B.

equipment regularly through FDD, technicians find and fix problems that would otherwise go undetected without a physical inspection. This technology better utilizes maintenance resources to spot equipment issues when they happen, preventing larger system failure. FDD systems for packaged HVAC equipment can be retrofit in the, or can be packaged with high-efficiency replacement equipment.

- *Energy Savings*

Based on an analysis of its potential impact on HVAC systems in the U.S., this technology would save .08 Quads of source energy per year.

Feng et al. (2005) found that although the performance of equipment will vary, the addition of packaged-unit FDD would save \$70/ton of cooling capacity per year by reducing failure rate if the noted repairs were made.

Sachs et al. (2009) estimated that adding FDD to packaged HVAC systems would save 20-30% on HVAC energy costs if the common problems found by the FDD were repaired.

e-News (2010) attributed a 10-30% reduction in efficiency of packaged units to fixable problems that could be found by the FDD systems.

Cost and Complexity

The cost and complexity of this technology depends on the capabilities and number of sensors for a particular FDD system. The type and number of sensors do not vary much with equipment size, so larger units provide greater potential savings and quicker payback. Preinstalled FDD systems will typically be less expensive and easier to install within the tight enclosures of the packaged units. Connecting many RTUs to a central data receiver reduces system costs as well.

Feng et al. (2005) estimated that the added cost of FDD to be \$80-300 for new packaged equipment. This price depends on the number and accuracy of sensors as well as the computing power of the controllers.

Armstrong et al. (2006) developed a NILM system that rapidly measures the electrical characteristics of certain components and alarms when the electrical signature of the unit differs from the efficient baseline. They estimated a \$200 per unit cost for manufacturers to incorporate this FDD method into their product line.

Brambley (2009) implemented another NILM system and predicted a \$200-400 increase to the cost of the packaged equipment. He noted that the price of the FDD sensors and equipment would not increase greatly with equipment size, so larger packaged units would have a more favorable payback.

Technical Maturity and Perceived Barriers to Market Adoption

This is an emerging technology with limited availability in the US market today. Manufacturers competitively price packaged units because they are usually installed on projects where lowest cost wins the job. The additional capabilities of FDD systems are valuable only if used appropriately. Once a maintenance or repair need is identified, it is up to the building operator to

fix the problem. Because of this, it is difficult to accurately predict energy savings when equipment usage, prevalence of faults, and operator participation varies widely.

When not tuned periodically in the field, the FDD system can experience false alarms and reduce effectiveness. The performance of the RTU depends on the age of components, environmental conditions, building loads, and other characteristics. If the predictive model is not updated regularly to accommodate these changing circumstances, the FDD system may indicate faults that don't exist. False positives consume maintenance resources, and potentially lead to technicians ignoring all diagnosed faults.

For FDD systems to be effective, the predictive model, detection thresholds, and sampling rate must be crafted to provide a robust system at competitive costs. This fine tuning of system characteristics is not well understood and there is much variability among the developed methods. HVAC systems are complex with a large number of state variables interacting together. So far, it has been difficult to reach a consensus strategy. Balancing FDD component complexity, cost, and energy benefit to the RTUs requires further investigation for this technology to be successful.

Next Steps for Technology Development

With the price of electronic sensors and microprocessors dropping, factory installed FDD systems should have minimal cost for parts and only require software development for a manufacturer. As more buildings move to energy management systems, incorporating packaged units in the FDD system should become common. In February 2011, the U.S. Department of Energy (DOE) and members of the Commercial Building Energy Alliance (CBEA) jointly drafted a "High-Performance Rooftop Air-Conditioning Specification". Members of the CBEA agreed to purchase equipment manufactured to meet these specifications that included automated fault detection and diagnosis. The success of FDD systems for RTUs will ultimately depend on how accurately and helpful the information is relayed to service technicians.

Table 3-46 presents the potential next steps for FDD in packaged HVAC equipment to gain greater market attention and acceptance.

Table 3-46: Recommended Next Steps for the Development of FDD in Packaged HVAC Equipment

Initiatives	Lead Organization(s)
Incorporate FDD capabilities in their product offerings, especially for the DOE/CBEA “High-Performance Rooftop Air-Conditioning Specification”	DOE, Manufacturers, Industry Organizations
Conduct field testing to compare various FDD methods, evaluating their complexity, cost, energy savings, and other benefits	DOE, Industry Organizations
Develop modeling and threshold industry standards to increase interoperability and prevent false alarms	DOE, Manufacturers, Industry Organizations
Offer incentives to building owners who install FDD systems or purchase HVAC equipment with FDD capabilities	DOE, Utilities

References

Armstrong et al. 2006. “Detection of Rooftop Cooling Unit Faults Based on Electrical Measurements.” HVAC&R Research, Vol. 12, No. 1, January 2006. p 151-175.

Brambley, MR. 2009. “A Novel, Low-Cost, Reduced-Sensor Approach for Providing Smart Remote Monitoring and Diagnostics for Packaged Air Conditioners and Heat Pumps.” Pacific Northwest National Laboratory. PNNL-18891.

Brodrick, James. 2000. “Are Fans Blowing Your Energy Budget?” HPAC Heating/Piping/Air Conditioning Engineering. December, 2000. P 74-77.

Commercial Building Initiative. 2011. “DOE and Private- Sector Partners Announce New Money-Saving Specification for Commercial Air Conditioners.” U.S. Department of Energy. EERE Information Center. February 2011.

e-News. 2010. “The Doctor Is Always In - Maintaining Optimum Performance with Fault Detection and Diagnostics (FDD).” Energy Design Resource. Issue 77, December 2010.

Feng et al. 2005. “Packaged Rooftop Units – Automated Fault Detection and Diagnosis.” ASHRAE Journal. April 2005. p 68-70.

Jacobs, Pete. 2003. “Small HVAC Problems and Potential Savings Reports.” California Energy Commission. P500-03-082-A-25. October 2003.

Roth et al. 2005. “Energy Impact of Commercial Building Controls and Performance Diagnostics: Market Characterization, Energy Impact of Building Faults and Energy Savings Potential. “ TIAX LLC. Reference No. D0180.

Sachs et al. 2009. “Emerging Energy-Saving HVAC Technologies and Practices for the Buildings Sector (2009)”. ACEEE Report Number A092.

4 Abridged Analyses of the Eight Early-Stage Technologies

During our research, we identified a small number of technologies for which there was a paucity of publicly available information, because they are still in the early stages of R&D. Because we were unable to find energy and cost savings estimates for these technologies, we could not evaluate them against the other technologies. Thus, we removed them from consideration for the final list of priority technologies, but recommend that DOE monitor their development. The remainder consists of abridged analyses for those eight technology options at an early stage of its development, including:

- Bernoulli Heat Pump
- Desiccant Assisted Evaporative Air-Conditioner (DEVap A/C)
- Metal Foam Heat Exchangers
- Nanofluid Refrigerant Additives
- Thermoelastic Cooling Cycle
- Thermoelectrically Enhanced Radiators
- Turbo Compressor-Condenser-Expander
- Zephyr Ceiling Tiles

4.1 Bernoulli Heat Pump

Brief Description	Bernoulli heat pumps use mixtures of rare gases as a working fluid to produce cooling. The working fluid is pumped through a Venturi neck and changes temperature as it travels through the neck. This effect can drive a heating or cooling system.	
Attribute	Value	Comments
Systems Impacted	All heating and cooling systems	
Relevant Annual Energy Consumption	1.09 Quads/yr	Potentially all vapor-compression systems
Retrofit Potential	Medium	Primarily to replace an existing cooling or heating plant
Non-energy Benefits	Elimination of high-GWP refrigerant emissions	

Description of Technology

Bernoulli heat pumps use mixtures of rare gases to move heat from one source to another. Instead of using mechanical compression of the working fluid to cause variations in temperature, Bernoulli heat pumps move their working fluid through a Venturi neck to achieve the same effect. This invention not only takes advantage of the Bernoulli principle, but also of the unusual thermodynamic transport properties of rare-gases.

Technical Maturity and Recent Developments

This technology is not commercially available, with a few significant technical issues that requires long-term R&D efforts before they are resolved.

Machflow, a small business associated with Clark University, produced a prototype of a Bernoulli heat pump (0.01 RT). The company has also filed eight patents regarding this technology. Machflow has received a Department of Energy grant from federal stimulus money and investment on venture capital firms. (Worcester Telegram 1)

Next Steps for Technology

The Bernoulli Heat Pump system is still at the research stage for mainstream air conditioning and refrigeration applications. Continued basic research is needed for the Bernoulli heat pump system to become a viable alternative to conventional vapor-compression technology. Some of the advances that must occur include identifying an appropriate working fluid (mixture of rare-gases), further refinement of a commercial design, and further development of a field-ready prototype.

References

(ClarkU 1) “Clark physicist’s green cooling tech startup gets \$1M stimulus grant.” September 1, 2010. <http://news.clarku.edu/news/2010/09/01/clark-physicist%E2%80%99s-green-cooling-tech-startup-gets-1m-stimulus-grant/>

(Worcester Telegram 1) Eckelbecker, Lisa. “Clark Business gets \$1M stimulus.” August 31, 2010. <http://www.telegram.com/apps/pbcs.dll/article?AID=/20100831/NEWS/8310335>

(Patent1) “Rare gas-based Bernoulli heat pump and method.” WIPO patent. WO 2007/017741 A2. Published February 15, 2007. <http://www.sumobrain.com/patents/wipo/Rare-gas-based-bernoulli-heat/WO2007017741.html>

<http://www.masshightech.com/stories/2008/05/26/weekly10-Clark-U-startup-goes-with-2M-flow.html>

<http://www.highbeam.com/doc/1P3-2315003531.html>

4.2 Desiccant Assisted Evaporative Air-Conditioner (DEVap A/C)

Brief Description	A desiccant-enhanced evaporative air-conditioner or DEVap A/C combines the functionality of both liquid desiccant and evaporative cooling systems. Using this integrated technology to control dehumidification and cooling separately, DEVap A/C can significantly reduce electricity consumption for space cooling, but also requires only a low-grade heating source.	
Attribute	Value	Comments
Systems Impacted	DX cooling systems	
Relevant Annual Energy Consumption	1.07 Quads/yr	
Retrofit Potential	Medium	The technology would replace packaged DX equipment, specifically rooftop units, but requires a heating source for the desiccant regenerator.
Non-energy Benefits	Eliminates refrigerant use, improves IAQ	

Description of Technology

The DEVap A/C combines both liquid desiccant and evaporative cooling technology, performing both latent cooling and dehumidification in one device. Combining these two strategies allows for the wider application of these non-vapor compression cooling principles. The DEVap system consists of two air channels arranged in a counterflow heat exchanger. An innovative vapor-permeable membrane separates the airstreams from the desiccant and water layers while allowing for heat and moisture transfer. The DEVap system provides cooling through the following process:

Step 1: Warm, humid air passes through the primary channel in the counterflow heat exchanger. This air is dehumidified and cooled by both a flowing liquid desiccant in the primary channel, and evaporative cooling in the secondary channel.

Step 2: Additional outside air, and a portion of the dry air leaving the primary channel diverts into the secondary channel of the counterflow heat exchanger. This dry air absorbs water from a water layer in the secondary channel and provides evaporative cooling for the primary channel.

Step 3: The remainder of the air leaving the primary channel enters the building to provide space conditioning and ventilation, and the exiting hot, humid air in the secondary channel exhausts to the outside.

The DEVap A/C does not use a compressor, but requires electricity to power air fans, and low volume water/desiccant pumps. It also requires a low-quality heating source from natural gas, solar thermal collectors, or waste heat sources to regenerate the liquid desiccant.

Technical Maturity and Recent Developments

This technology is not commercially available, with a few product development issues to be resolved through short-term R&D activities. NREL is currently testing and optimizing prototypes, with the anticipation of licensing the technology to HVAC manufacturers within 5 years.

Kozubal, et al. (2011) developed models for the DEVap A/C process and compared it to a high efficiency DX system in various U.S. cities. The modeled DEVap A/C system reduced source energy consumption by 50-90% and peak electricity demand by 80% over the DX system while providing the same cooling and humidity conditions. Lab testing of initial prototypes has verified these models and uncovered additional areas for design improvement.

Next Steps for Technology

Continued prototype refinement and testing should lead to further improvements on the DEVap A/C design. Optimizing liquid desiccant concentration, heat exchanger design, regenerator advances will raise efficiency and reduce costs for a commercial model. Research should focus on O&M lifecycle considerations, solar regenerator heating, and the benefit of increased ventilation over a DX system.

Also see Section 3.2.1 on liquid desiccant systems and Section 3.2.3 on solar enhanced cooling systems.

References

Kozubal, et al. 2011. “Desiccant Enhanced Evaporative Air-Conditioning (DEVap): Evaluation of a New Concept in Ultra Efficient Air Conditioning.” NREL Report No. NREL/TP-5500-49722.

Slayzak and Kozubal. NREL. 2009. “Indirect Evaporative Cooler Using Membrane-Contained, Liquid Desiccant for Dehumidification.” World Intellectual Property Organization. Publication No. WO/2009/094032.

4.3 Metal Foam Heat Exchangers

Brief Description	Heat exchangers made from porous conductive metal foams could achieve greater heat transfer efficiencies than conventional designs. These metal foams could make up the entire heat exchanger, or act as fins.	
Attribute	Value	Comments
Systems Impacted	Heat Exchangers	
Relevant Annual Energy Consumption	2.25 Quads/yr	Potentially all heat exchangers
Retrofit Potential	High	Primarily as a component in replacement equipment
Non-energy Benefits	Reduced refrigerant use	

Description of Technology

Heat exchangers (HX) transfer energy from one fluid to another in HVAC systems. Typically fin and tube or flat plate HXs constructed from solid metal provide liquid to liquid, liquid to gas, and gas to gas heat transfer (HT). Novel HX technologies using advanced metal foams lowers fan consumption, raises HT, and reduces material usage. The advanced materials will either be joined with conventional metal tubes to enhance HT as fins, or directly make up the entire HX surface. In addition to HVAC, metal foam HX materials are in development for fuel cells, power electronics, and industrial processes.

Metal foam HXs consist of a geometric lattice of a porous conductive material ideal for HT applications. The low material density allows a working fluid to pass through the metal foam, exchanging heat very efficiently. As the fluid passes through the foam, the individual metal strands agitate and cause the flow to become turbulent, increasing HT. The foam can be annealed and compressed to further raise HX density, but with a higher pressure drop. This type of advanced HX material has a higher surface area to volume ratio and efficiency than conventional HX systems for the same application. For compressed metal foams, the subsequent rise in fan work is offset by the large efficiency gains in HT. The metal foam can take the place of metal fins for fin and tube HXs with greater capacity and less material.

Technical Maturity and Recent Developments

This technology is not commercially available, with a few significant technical issues that requires long-term R&D efforts to resolve. No proof of concept testing has occurred for HVAC systems. AHRTI (2010) is supporting a project which will examine the HVAC applications of metal foam HX materials and develop a prototype for testing.

Boomsma et al. (2003) found that aluminum metal foams compressed into a compact HX system lowered thermal resistance by 50% compared to traditional HX technology.

Ozmat et al. (2007) tested a compressed metal foam HX with use in electronics and found a 2.5-3.5 fold increase in HT performance. Additionally, fan requirements increased 1.3-1.5 fold.

Next Steps for Technology

Much research and testing is needed to develop metal foam HXs for use in HVAC systems. Little is known of the reliability of a metal foam system in practical environments over time, especially with the presence of condensation. Only HX systems which have low particulate concentrations will be applicable with metal foams because dust buildup in the metal web decreases efficiency significantly. Methods to join the metal foams as fins to copper HVAC tubes need to be developed. Long-term research is need for HVAC applications with currently available metal foam technology.

References

AHRTI. 2010. "Novel Materials for Heat Exchangers: Phase II." AHRTI Project Summary. Revised June, 2010.

Boomsma et al. 2003. "Metal Foams as Compact High Performance Heat Exchangers." Journal of Mechanical Materials. Volume 35. p 1161–1176.

Haack et al. 2001. "Novel Lightweight Metal Foam Heat Exchangers." Porvair Fuel Cell Technology, Inc.

Mahjoob and Vafai. 2008. "A Synthesis of Fluid and Thermal Transport Models for Metal Foam Heat Exchangers." International Journal of Heat and Mass Transfer. Volume 51. p 3701-3711.

Ozmat, Burhan. 2007. "Reticulated Metal Foams Build Better Heatsinks." Power Electronics Technology. November 2007. p 24-29.

4.4 Nanofluid Refrigerant Additives

Brief Description	Specific solid metals can be produced on a nanoscale (<100nm) level and suspended in a normal working fluid to create a nanofluid with enhanced thermal properties. These nanoparticle additives can assemble in layers on piping to enhance heat transfer and also enhance the thermal conductivity of the working fluid.	
Attribute	Value	Comments
Systems Impacted	Nearly all cooling plants and all non-ducted delivery systems	
Relevant Annual Energy Consumption	2.25 Quads/yr	Potentially all cooling working fluids
Retrofit Potential	High	Primarily in refrigerant-based cooling/heating systems and in non-ducted delivery systems
Non-energy Benefits	None	

Description of Technology

Compared to metals, the conventional heat transfer fluids of water, oil, glycol, and other refrigerants have poor thermal conductivity. In order to improve efficiency in HVAC systems, working fluids should be able to transfer more heat with less mechanical input. Specific solid metals can be produced on a nanoscale (<100nm) level and suspended in a normal working fluid to create a nanofluid with enhanced thermal properties. By having high thermal conductivity metals integrated into the fluid itself, high efficiency nanofluids can be used under normal operating temperatures.

Nanoparticle additives can work in a number of ways to enhance heat transfer. Once introduced to piping, certain nanofluids create self-assembled monolayers on the pipe itself to enhance dropwise condensation. This achieves significantly higher heat transfer due to the higher surface area of its beads compared to a liquid film. The nanofluids have a higher total thermal conductivity since they partially consist of higher conductive metal. The suspended nanoparticles amplify convective heat transfer with the increased motions caused by particle interactions at such a high density ($\sim 10^{23}/\text{m}^3$).

Technical Maturity and Recent Developments

This technology is not commercially available, with a few significant technical issues that require long-term R&D efforts before they are resolved. Both reductions and enhancements in heat transfer efficiency have been experimentally determined through nanofluid use. Peng et al. (2011) found that nanofluid enhanced refrigerant boiling efficiency is determined by a mix of the following:

1. Size of nanoparticles
2. Type of working fluid
3. Concentration of nanofluid
4. Heat flux in the heat exchanger
5. Heat exchanger configuration

Limited experimentation has been conducted to try and standardize the impact of nanofluids across all of these factors. Predictive models are only starting to be developed in order to optimize these design conditions.

Next Steps for Technology

Testing of nanoparticle enhanced working fluids needs to be increased in order to definitively determine which combinations of conditions produce gains in efficiency. Nanoparticles have a variety of uses outside of HVAC and their development will allow for the availability of the materials once proven. During experimentation, nanofluids often deviate from the normal behavior of thermal fluids. Basic research into the composition and thermal properties of nanofluids will provide a foundation for further experimentation with HVAC applications.

References

Choi, Stephen. 1999. "Nanofluid Technology: Current Status and Future Research." Argonne National Laboratory. Energy Technology Division.

Kedzierski, Mark. 2007. "Effect of CuO Nanoparticle Concentration on R134a/Lubricant Pool Boiling Heat Transfer with Extensive Analysis." National Institute of Standards and Technology. NISTIR 7450.

Khandekar et al. 2007. "Thermal Performance of Closed Two-phase Thermosyphon Using Nanofluids." International Journal of Thermal Sciences 47 (2008). p 659–667.

Kim, Kwang. 2003. "Advanced Heat Exchangers Using Tunable Nanoscale-Molecular Assembly." Presented at University Coal Research / Historically Black Colleges and Universities & Other Minority Institutions Contractors Review Meeting. June 10-11, 2008.

Manca et al. 2010. "Heat Transfer in Nanofluids." Advances in Mechanical Engineering. 2010.

Peng et al. 2011. "Migration of Carbon Nanotubes from Liquid Phase to Vapor Phase in the Refrigerant-based Nanofluid Pool Boiling." Nanoscale Research Letters 2011, 6:219.

4.5 Thermoelastic Cooling

Brief Description	Thermoelastic cooling system utilizes shape-memory metal alloy that alternately absorbs or creates heat through its thermoelastic characteristics.	
Attribute	Value	Comments
Systems Impacted	All electric-powered A/C systems	
Relevant Annual Energy Consumption	1.07 Quads/yr	~50% of the entire electric-powered A/C system energy consumption, given the retrofit challenges.
Retrofit Potential	Medium	The technology does not require any changes to existing delivery of cooling, but requires changes to cooling plant. Not compatible with vapor-compression systems.
Non-energy Benefits	Reduced refrigerant use	

Description of Technology

Thermoelastic cooling system uses “thermally elastic” metal alloy as a solid coolant in place of fluids used in conventional refrigeration and air conditioning compressors. A two-state alloy alternately absorbs or creates heat in much the same way as a compressor-based system. These alloys are commonly used for a variety of other applications such as stents, braces and eyeglass frames [Takeuchi, (2011)]. Much like other novel cooling systems, thermoelastic cooling system eliminates the need for a compressor and refrigerant, which would reduce energy consumption associated with the entire air conditioning process.

Technical Maturity and Recent Developments

This technology is not commercially available, with a few significant technical issues that requires long-term R&D efforts before they are resolved. The Department of Energy has funded \$500,000 to the University of Maryland (UMD), General Electric Global Research and the Pacific Northwest National Laboratory as a part of its Advanced Research Projects Agency-Energy (ARPA-E) program to pursue further R&D on thermoelastic cooling technology [UMD (2010)]. The lead researchers on the team include Ichiro Takeuchi, Manfred Wuttig and Jun Cui at UMD have developed a solid coolant to take the place of fluids used in conventional refrigeration and air-conditioning compressors.

Next Steps for Technology

There remain significant technical hurdles for the thermoelastic cooling system to overcome before it can enter commercial HVAC market. The researchers claim that, once fully developed, thermoelastic refrigeration cycles could increase cooling efficiency by 175 percent compared to the conventional vapor-compression cooling cycle [APRA-E (date unknown)]. Furthermore, Takeuchi (2011) estimates that with optimization, the thermoelastic cooling system could achieve a COP as high as 12. However, the technology is not yet ready to be developing into a prototype system, given the insufficient cooling capacity and other challenges.

Key next steps for the technology are to continue the ongoing R&D effort to test the prototype thermoelastic cooling system, and upon successful completion, move onto larger scale demonstration toward establishing the viability of thermoelastic cooling for space-cooling applications.

References

Advanced Research Projects Agency – Energy (ARPA-E), date unknown. “University of Maryland: Thermoelastic Cooling”. Building Energy Efficiency through Innovative Thermodevices (BEETIT) Project Description. Retrieved July 12, 2011 from <http://arpa-e.energy.gov/ProgramsProjects/BEETIT/ThermoelasticCooling.aspx>

Energy Efficiency & Technology (EE&T), 2010. "No more compressors for HVAC? Unnecessary with a solid coolant". Retrieved July 12, 2011 from http://eetweb.com/applications/solid_coolant_072310/.

University of Maryland (UMD), 2010. “New ‘Smart’ Metal Could Mean Cool Cash for Consumers, Less CO2”. *Vibrant State*. UMD Newsdesk. July 15. Retrieved June 20, 2011 from <http://newsdesk.umd.edu/vibrant/release.cfm?ArticleID=2198>.

Takeuchi, I., 2011. “Thermoelastic Cooling: Shape Memory Alloys as a Novel Solid State Refrigerant. Presentation given at University of Maryland Engineering Sustainability Workshop 2011. Retrieved July 11, 2011 from <http://lecture.umd.edu/detsmediasite/Viewer/?peid=b537b417ac8c4b6eb19d7a2d7d83afe31d> (min 28-42).

4.6 Thermoelectrically Enhanced Radiators

Brief Description	For hydronic heating radiators, thermoelectric generators placed along hot-water pipes can power auxiliary fans that raise system efficiency. The fans create greater airflow, increasing heat transfer to the room for the same hot-water flow rate.	
Attribute	Value	Comments
Systems Impacted	Hydronic Heating	
Relevant Annual Energy Consumption	0.78 Quads/yr	Gas hydronic heating systems
Retrofit Potential	High	Where hydronic heat is already available
Non-energy Benefits	Smaller equipment footprint	

Description of Technology

A temperature difference across thermoelectric materials can function as an electric generator. A typical hot-water radiator uses natural convection to heat a space and can increase efficiency from the use of these embedded mini-generators. The hydronic supply pipe delivering heat to a room is hot enough to run small thermoelectric generators placed along the length of the pipe. The voltage from the thermoelectric generators powers a set of auxiliary DC fans, creating greater convective airflow and distributing heat more efficiently without external power input or control. The pipe heat loss to the thermoelectrics is minor compared to the gain in heat-transfer efficiency contributed to the fans.

Technical Maturity and Recent Developments

This technology currently is only available for convective hydronic heating applications, but the potential of thermoelectric generation systems could be much wider in HVAC. In 2010, S & P Coil Products Limited (U.K.) included thermoelectric enhancements as part of their MINIB hydronic trench heaters. An auxiliary fan powered by thermoelectric generators created a 300% increase in airflow compared to a naturally-convected unit. The thermoelectrically-enhanced radiator improved its heating capacity from 50 W/m to 100 W/m for the same amount of hot water.

Next Steps for Technology

Much work is underway in the automotive industry to develop thermoelectric generators to harvest energy from hot exhaust gases. Once fully understood, thermoelectric generators could be applied to other HVAC components to enhance heat transfer without any additional power input. This technology option requires extensive testing to evaluate the capabilities of the heat transfer enhancement and its effect on energy consumption. Upon successful testing, product development should focus on improving the reliability and cost-competitiveness of a compact, thermoelectrically enhanced radiator for hydronic heating.

References

DeStees and Olsen. 2010. "Thermoelectric power source utilizing ambient energy harvesting for remote sensing and transmitting." Pacific Northwest National Laboratory. Technology ID 12398-E, 13664-B. Patent no. 7,834,263

MINIB. 2011. "2011 MINIB Catalog." p 69.

SPC. 2010. "SPC Introduce New Revolutionary Peltier Heater." S & P Coils Products Limited. News section of website. January, 19th 2010. <http://www.spc coils.co.uk>

4.7 Turbo-Compressor-Condenser-Expander

Brief Description	This technology combines the compressor, condenser, and expansion valve of a typical vapor-compression system into an integrated package with greater system efficiency.	
Attribute	Value	Comments
Systems Impacted	Packaged vapor-compression systems	
Relevant Annual Energy Consumption	0.76 Quads/yr	Potentially all packaged vapor-compression cooling equipment
Retrofit Potential	High	This technology would replace the compressor, condenser, and expansion device in packaged vapor-compression systems
Non-energy Benefits	Uses natural refrigerants, improved capacity control	

Description of Technology

The standard vapor-compression cycle utilizes a compressor, condenser, expansion valve, and evaporator to add/remove heat from a space. The turbo-compressor-condenser-expander (TCCE) or isothermal turbocompressor (ITC) combines the separate pieces of system equipment into an integrated device driven by a single motor. The TCCE system consists of two sets of radial spokes connected by a thin plenum. Refrigerant gas enters the TCCE and is centrifugally compressed outward through the top spokes. The refrigerant travels through the condensing plenum and cools as the spinning blades create airflow through the TCCE. The rotating bottom spokes collect and expand the cooled refrigerant before exiting to the evaporator. The TCCE reduces the number of components in a vapor-compression HVAC system while providing efficiency ratings greater than 20 SEER.

The TCCE reduces energy use for vapor-compression equipment by combining systems to maximize heat transfer. The centrifugal motion of the near isothermal compression drives the convective heat transfer and isentropic expansion. The reversible centrifugal decompression of the cooled liquid-vapor in the bottom spokes provides mechanical torque to the shaft, reducing motor requirements. Without reciprocating devices, the TCCE can operate over a range of liquid-vapor conditions allowing for the variable speed motor to control capacity.

Technical Maturity and Recent Developments

This technology is not commercially available, with a few significant technical issues that requires short-term R&D efforts to resolve. Appollo Wind Technologies, LLC developed the TCCE which was invited as a “Showcase Technology” at the 2011 ARPA-E Energy Innovation Summit. An initial proof of concept prototype has been built and tested with second generation system under development for expanded field testing. The first prototype built with off-the-shelf components had a capacity of 1.1+ tons with promising results.

Next Steps for Technology

Packaged HVAC units would greatly benefit from this technology once fully developed. The TCCE would offer a viable CO₂ cooling system with high-efficiency, and decreased maintenance

costs. A full working prototype must be constructed and then integrated into a working HVAC system for wider demonstration. Reliability testing in a variety of conditions must be performed due to the industry's unfamiliarity with this technology.

References

Appollo Wind Technologies, LLC. 2011. Retrieved from <http://www.appollowind.com>.

Roisin et al. Appollo Wind Technologies LLC. 2010. "Turbo-compressor-condenser-expander." World Intellectual Property Organization. Publication No. WO/2010/090866

Swett, P. and Hannon, J. 2011. Personal Communication. Appollo Wind Technologies, LLC.

4.8 Zephyr Ceiling Tiles

Brief Description	By replacing a conventional drop-ceiling, Zephyr ceiling tiles (ZCT) use the low relative humidity of return air to provide additional space cooling. The return air flows over a wicking material in the ZCT, cooling the ceiling, and reducing the need for traditional cooling.	
Attribute	Value	Comments
Systems Impacted	Ducted cooling systems	
Relevant Annual Energy Consumption	1.07 Quads/yr	Offsets cooling load for any type of system
Retrofit Potential	Medium	Primarily for new construction, but renovation or fit-out projects requiring a new ceiling would apply
Non-energy Benefits	Reduced refrigerant use	

Description of Technology

For ducted cooling systems, the hot, dry return air can further cool a space via latent heat transfer. Possessing a low relative humidity, the exhaust air can absorb water vapor and provide evaporative cooling. Designed for commercial drop-ceilings, The Zephyr ceiling tile (ZCT) system channels return air over a moist layer of wicking material. As the dry air passes over the wicking sheet, water evaporates and latently cools the ceiling tile. The tile then extracts additional heat from the conditioned space, reducing the load required by the conventional air-conditioning system. The ZCTs use the dry exhaust air to provide additional cooling with only minimal power requirements. In most instances, only small pumps will be required to replenish the wicking layer. The evaporative cooling provided by the ZCTs either augments or replaces part of the air conditioning supplied by the current forced air system. This raises overall cooling system efficiency without major changes to existing operations.

Technical Maturity and Recent Developments

This technology is not commercially available, with a few product development issues to be resolved through short-term R&D activities. A room-scale prototype has been successfully tested to confirm modeled savings. Secondary issues such as tile integration and material reliability have been resolved, and the technology is in the commercialization phase.

Professor Harry Salt and Professor Dennis Loveday at Loughborough University (U.K.) have developed the ZCT system. They measured the performance of the ZCT system in a test chamber with a ceiling covered 70% by ZCTs. Compared to a conventional system alone for various heat gains, the ZCTs reduced energy consumption to cool the room by:

- 65% for 36 W/m²
- 51% for 54 W/m²
- 50% for 73 W/m²
- 37% for 91 W/m².

Next Steps for Technology

Ongoing research into the viability of this novel cooling strategy will reveal its applicability for commercial buildings. Field testing with a market-ready product in an office setting and in various climate locations should provide the necessary data to fully evaluate the ZCT system. Commercial office buildings will be the first adopters of this technology with their prevalent use of drop-ceilings. Current collaboration with a leading ceiling manufacturing company should facilitate commercialization.

References

Loughborough University. 2009. "University System Makes Top Five of International Climate Change Competition." <http://www.lboro.ac.uk/>. March 19th, 2009. PR 09/35.

Loveday, Dennis and Salt, Harry. 2011. Loughborough University. Co-inventors of Zephyr Ceiling Tile. Personal Communication. April, 2011.

Salt and Loveday. Loughborough University Innovations LTD. 2002. Patent Application No. PCT/GB01/04532. World Intellectual Property Organization. Publication No. WO 02/33326 A1.

5 Conclusions

In this study, we identified a wide range of technology options having the potential to reduce commercial HVAC energy consumption. In this section, we:

- Summarize the screening process through which we identified the final priority technology options on which to perform an in-depth analysis
- Compare the list of the 17 priority technology options and the technologies included in Roth, et al. (2002)
- Discuss general observations regarding the current state of development for the 17 priority technology options
- Recommend high-level RD&D initiatives that would help advance these technology options.

5.1 Summary of the Technology Screening Process

We identified a wide range of technology options having the potential to reduce commercial HVAC energy consumption in U.S. buildings. This included energy-saving HVAC technology options at various stages of development, from those in proof-of-concept research to those that are widely adopted in the market. After a thorough literature survey, we developed a comprehensive list of 182 technology options, and evaluated their technical energy-savings potential and applicability to various HVAC equipment/system types. From this comprehensive list, we selected and analyzed 57 technology options to better understand each technology options' energy savings, cost/complexity, retrofit potential, non-energy benefits, potential for peak-demand reduction, technical maturity, and next steps for development. Section 3 describes each of the 57 technology options.

After establishing the scoring criteria for the second round of technology screening, we scored each of the 57 technology options based on our research and the input of HVAC experts within Navigant. Through this process, we identified the top technologies which clearly scored above the rest and best fit the goals of this report. We analyzed in detail the remaining 17 priority technology options and recommended next steps for their continued development. Each of the 17 priority technology options features significant technical energy-savings potential²⁰ (see **Figure 5-1**). In some cases, multiple technology options target the same savings opportunity through different approaches (e.g., Retrocommissioning and Continuous Commissioning). For these technology options, the technical energy-savings potentials are not additive.

²⁰ Technical energy-savings potential is the theoretical national primary energy savings that could be achieved if all technically suitable installations are replaced with a particular energy-saving technology.

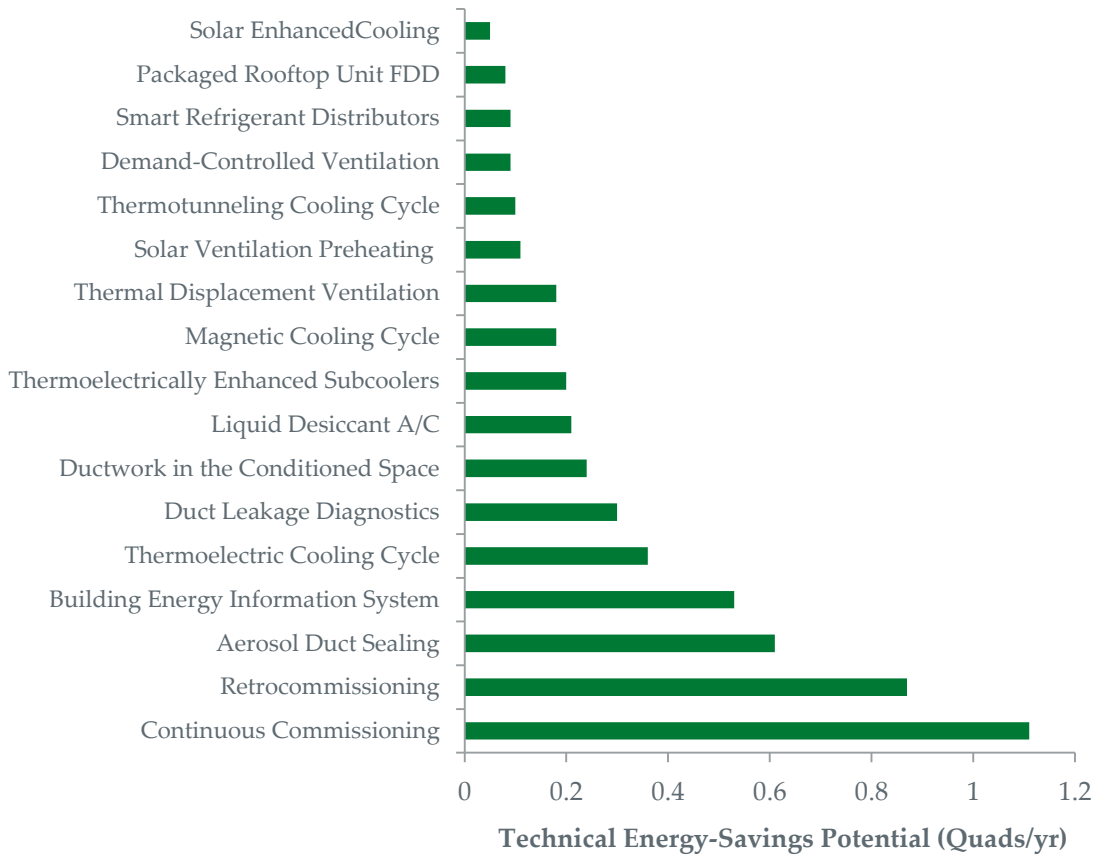

a. Potential savings are not additive for most technology options and applications

Figure 5-1: Technical Energy-Savings Potential for the 17 Priority Technology Options^a

Because technical energy-savings potential depends both on the applicability of the technology across HVAC equipment/systems and the projected annual unit energy savings, technology options that address both heating and cooling (e.g., Aerosol Duct Sealing) or benefit multiple HVAC system types (e.g., Retrocommissioning) have the largest technical energy-savings potentials. Technology options that are readily retrofit into existing buildings either as a supplementary system (e.g., Building Energy Information System) or could be integrated in replacement equipment (e.g., Thermoelectric Cooling Cycle) have higher technical energy-savings potential as well.

5.2 Comparison with 2002 TIAX Study

As discussed in Section 1.2, DOE-BT commissioned a similar study in 2002 [Roth, et al. (2002)]. One difference between the current study and the 2002 study is that we considered fit with DOE-BT’s mission as a screening criterion, whereas the 2002 study did not. This led us to choose some technology options for the in-depth analysis that the 2002 study screened out. On the other hand, we determined that some technology options that the 2002 study analyzed in depth are either widely adopted today, would not benefit significantly from future DOE involvement in its development, or both. Either case would suggest that these technology options are a poor fit with DOE-BT’s mission, and, therefore, we screened them out. **Table 5-1**

compares the technology options analyzed in detail in the current study to those analyzed in detail in the 2002 study.

Table 5-1: Comparison of Technology Options Analyzed to those Analyzed by Roth, et al. (2002)

Technology Options	2011	2002	Notes
Liquid Desiccant Air-Conditioner	●	●	The technology has advanced from conceptual stage to limited commercial demonstrations since 2002. Several key technical challenges (e.g., desiccant carryover) have been addressed, and several demonstration units have been manufactured. However, it is still far from widespread commercial availability. Additional work is needed to make these systems truly competitive with vapor-compression systems.
Thermal Displacement Ventilation	●	●	Recent efforts that started to address key challenges identified in 2002, including verification of performance in various climates. However, continued effort is required to address remaining challenges on a national scale, which would be appropriate for DOE to lead.
Aerosol Duct Sealing (Improved Duct Sealing)	●	●	The 2002 study discussed Aerosol Duct Sealing under “Improved Duct Sealing”. This study focuses on aerosol sealing as opposed to other solutions because aerosol duct sealing systems remain the only technology designed to repair existing duct systems with minimal invasiveness, aside from labor-intensive visual inspections and repair. Recent studies have confirmed the effectiveness of aerosol duct sealing (mostly in residential settings, but in some commercial settings as well). However, a key remaining challenge is increasing the rate of market adoption, especially in the commercial sector.
Building Energy Information System	●	(●)	The 2002 study addressed the savings opportunities associated with performance optimization and diagnostics under “System/ Component Diagnostics”. With advances in supporting technologies, these technology options are starting to be adopted by the market. However, there continues to be a strong need for DOE and industry support to improve the market adoption of these technologies.
Continuous Commissioning	●	(●)	
Duct-Leakage Diagnostics	●	(●)	
Packaged RTU FDD	●	(●)	
Retrocommissioning	●	(●)	
Magnetic Cooling Cycle	●	○	The 2002 study does not document why these technologies were screened out. This study includes them because of their strong fit with DOE-BT’s mission and high technical energy-savings potential. Researchers have made incremental improvements in basic science (e.g., new materials) and system design since 2002 for these technology options. As a result, thermo-electric, in particular, have gained greater market acceptance in smaller-capacity applications.
Thermoelectric Cooling Cycle	●	○	
Demand-Controlled Ventilation	●	○	These technology options have become more viable since 2002 because of

Technology Options	2011	2002	Notes
Smart Refrigerant Distributors	●	×	advances in supporting technologies, particularly sensors and control devices. This study includes them because of their strong fit with DOE-BT's mission and high technical energy-savings potential.
Solar Enhanced Cooling	●	×	The 2002 study did not consider solar-assisted technologies. This study includes them because of their strong fit with DOE-BT's mission and high technical energy-savings potential.
Solar Ventilation Preheating	●	×	
Thermoelectrically Enhanced Subcoolers	●	×	The 2002 report did not break out this technology option separately from the Thermoelectric Cooling Cycle. The current study considers this option separately because the low-capacity requirements leverage the inherent advantages of thermoelectric cooling systems.
Thermotunneling Cooling Cycle	●	×	This technology emerged over the last decade, thanks to advances in nano-scale engineering of materials and increased understanding of quantum mechanical effects. Thermotunneling represents an improvement over older thermoelectric and thermoionic technologies, and its remaining RD&D needs fit well with DOE-BT's mission.
Ductwork in Conditioned Space	●	×	The 2002 report does not mention this technology option. The current study identified it as a priority technology option because of its high technical energy-savings potential. While this technology option is not new, it has received increased attention in recent years due to renewed interest in energy-efficient and sustainable building designs and retrofits. However, further RD&D is required to adapt this strategy in existing buildings where duct leakage is a main source of thermal energy loss.
Adaptive and Fuzzy Logic Control	×	●	Screened out or not considered in the current study mainly due to relatively poor fit with DOE-BT mission. Technical energy-savings potentials were not sufficiently large to overcome their poor DOE fit.
Dedicated Outdoor Air Systems	○	●	
Electrically Commutated Motors	○	●	
Enthalpy/Energy Recovery Heat Exchanger	○	●	
Microchannel Heat Exchangers	○	●	
Radiant Ceiling Cooling/Chilled Beam	○	●	
Variable Refrigerant	○	●	

Technology Options	2011	2002	Notes
Volume/Flow			
Microenvironment	○	●	Screened out mainly in the current study due to low technical energy-savings potential. The technical energy-savings potential is low because of its low retrofit potential. Also, its DOE fit was too small to overcome its poor technical energy-savings potential.
Thermal Energy Storage	○	●	Screened out in the current study mainly due to low technical energy-savings potential. The 2002 report suggests notable energy-savings potential, but TES is considered to be a peak-demand reduction strategy today.
Cold-Weather Heat Pump	○	●	Screened out in the current study mainly due to low technical energy-savings potential compared to high-efficiency gas equipment. Challenges associated with the technology are mainly in the realm of product design and development.
Small Centrifugal Compressors	○	●	Screened out in the current study mainly due to relatively poor fit with the DOE-BT mission. The introduction and success of Danfoss' Turbocor centrifugal compressor line over the last decade has reduced the need for DOE involvement.
<p>● - Included in the in-depth analysis (●) – Included in the in-depth analysis, but combined into one entry ○ - Considered in the study but was screened out × - Not considered in the study</p>			

5.3 Observations on the Final Priority Technology Options

5.3.1 Technology Categories

Through the screening process, we analyzed a wide spectrum of technology options available for achieving HVAC energy savings in U.S. commercial buildings. Table 5-2 describes four technology categories by which we grouped the technology options. The categories represent a top-level breakdown of the complex HVAC systems used in commercial buildings:

Table 5-2: Descriptions of the Categories used to group the Final Priority Technology Options

Category	Energy-Savings Opportunity
Advanced Component Technologies	Optimizing the performance of critical components offsets the energy consumption of conventional HVAC systems
Alternative Heating & Cooling Technologies	Novel technologies and strategies that can provide heating or cooling more efficiently, often using renewable heating sources or non-vapor-compression cooling cycles
Thermal Distribution Systems	Eliminating duct leakage and maximizing the performance of thermal distribution systems consisting of ducts, pipes, and other mechanisms that deliver space conditioning to building occupants.
Performance Optimization & Diagnostics	Monitoring, measurement, and benchmarking of HVAC system operations to maintain peak performance over the life of the equipment

5.3.2 Non-Energy Benefits

In addition to reducing energy consumption, many of the priority technology options selected for in-depth analysis feature non-energy benefits as well (**Table 5-3**). These additional benefits provide both qualitative and quantitative value to building owners and occupants. In many instances (e.g., data centers, which have critical temperature and humidity requirements), the non-energy benefits may be far more important than energy savings.

Table 5-3: Non-Energy Benefits for the Final Priority Technology Options

Technology Option	Applicable Non-Energy Benefits					
	Improved Occupant Comfort	Improved Indoor Air Quality	Equipment Down-Sizing	Noise Reduction	FDD Capabilities / Extends Equipment Life	Less Refrigerant Charge
Aerosol Duct Sealing	✓	✓	✓	✓		
Building Energy Information System					✓	
Continuous Commissioning	✓	✓			✓	
Demand-Controlled Ventilation	✓	✓			✓	
Duct-Leakage Diagnostics		✓		✓		
Ductwork in Conditioned Space	✓	✓	✓			
Liquid Desiccant Air-Conditioner	✓	✓	✓			
Magnetic Cooling Cycle						✓
Packaged RTU FDD	✓			✓	✓	
Retrocommissioning	✓	✓	✓		✓	
Smart Refrigerant Distributors					✓	✓
Solar Enhanced Cooling						
Solar Ventilation Preheating						
Thermal Displacement Ventilation		✓		✓		✓
Thermoelectric Cooling Cycle				✓		✓
Thermoelectrically Enhanced Subcoolers			✓			✓
Thermotunneling Cooling Cycle				✓		✓

5.3.3 Technical Maturity

As **Figure 5-2** presents, the final priority technology options cover a broad range of development status. For R&D technology options, **Figure 5-2** shows both conservative and more optimistic (“Max”) projections of technical energy-savings potential, the latter based on the most optimistic projections found in the literature.

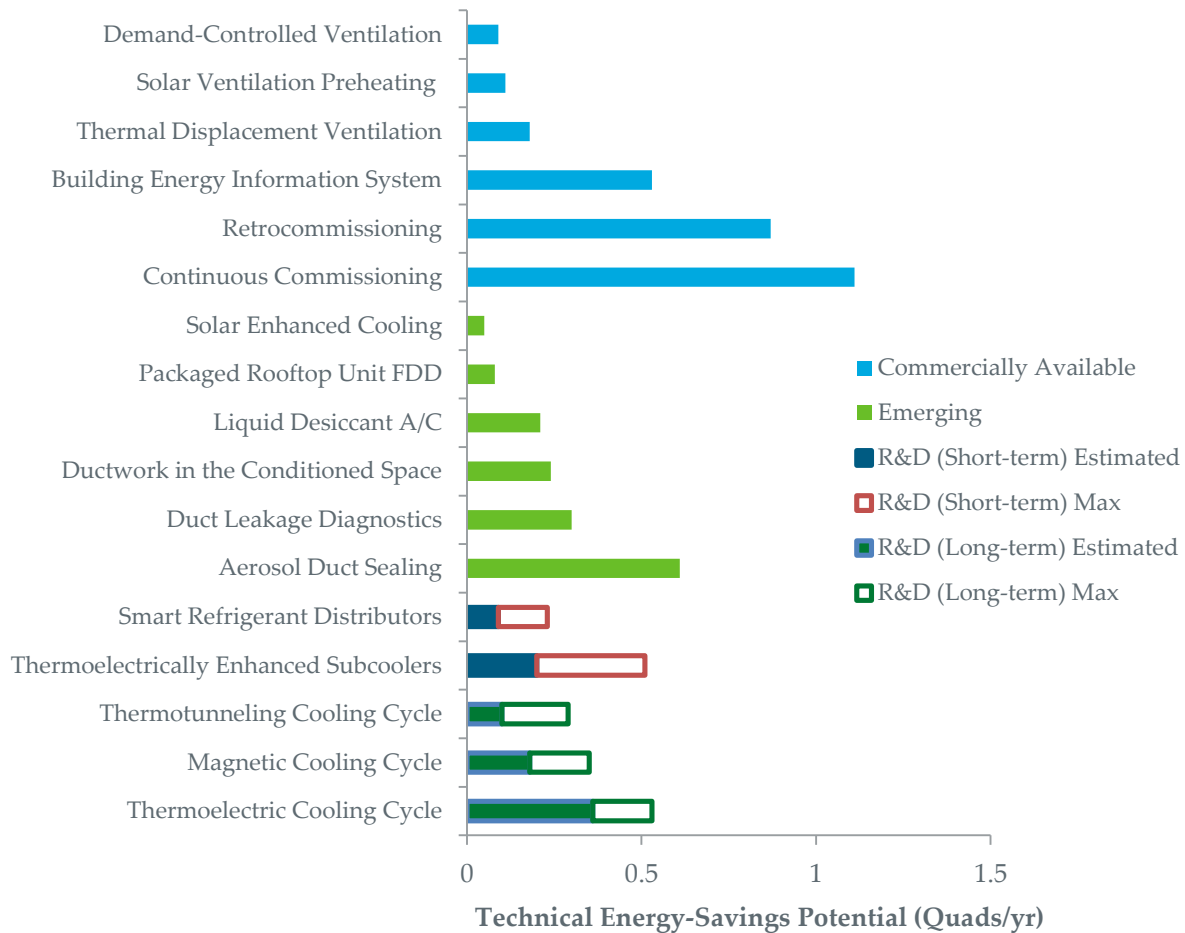

Figure 5-2: Technical Energy-Savings Potential for the Final Priority Technology Options by Technical Maturity

Throughout this study, we have used conservative projections for the technical energy-savings potentials of technology options in the R&D phase for the following reasons:

- Significant advances in material science must occur for successful development of technology option (e.g., Thermotunneling Cooling Cycle)
- Issues exist relating to the scalability of the technology option for commercial HVAC systems (e.g., Smart Refrigerant Distributors)
- Lack of proven performance from testing in real-world conditions over time (e.g., Thermoelectrically Enhanced Subcoolers).

5.3.4 Cost and Complexity

It is difficult to quantify the upfront cost and complexity for technology options not yet widely available. Key challenges include:

- Cost (and performance) claims by technology developers are often unsubstantiated, with few publicly available, independent, detailed examinations;

- Wide variations in upfront costs and depending on site-specific conditions and characteristics for certain technology options; and
- Uncertainties in cost associated with the current development status of the technology.

In most cases, we evaluated cost/complexity qualitatively, considering the incremental first cost and the added complexity associated with installation, operation, and maintenance for the technology option compared to conventional technology.

Given that the available information may be biased or unreliable for immature technology options, we focused our economic analysis on technologies closer to commercialization. Developers of technology options in early-stage R&D often project costs based on large economies of scale and mature manufacturing techniques. Many of these technology options still require significant material-science improvements to demonstrate technical viability. Nevertheless, some of these early-stage technology options may reduce equipment complexity because they have fewer moving parts, potentially lowering maintenance requirements and providing higher reliability.

Table 5-4 categorizes estimated cost/complexity for the technology options closest to widespread market availability. For most of the technology options, potential energy-savings impacts (and even first costs) vary widely depending on the specific building type, size, location, existing HVAC systems, etc. Even with this uncertainty, these technology options typically have low cost/complexity leading to favorable economics and energy savings for a variety of buildings, especially where HVAC loads are high. Section 3 discusses the cost/complexity for each priority technology option.

Table 5-4: Estimated Cost/Complexity for Technology Options Closest to Widespread Market Availability

Categorization of Cost/Complexity for Technology Options Closest to Widespread Market Availability	
Potential for Similar Cost/Complexity	Retrocommissioning
Slightly Higher Cost/Complexity	Aerosol Duct Sealing Building Energy Information System Continuous Commissioning Ductwork in Conditioned Space Packaged RTU FDD Thermal Displacement Ventilation
Moderately Higher Cost/Complexity	Demand-Controlled Ventilation Duct-Leakage Diagnostics Liquid Desiccant A/C Solar Enhanced Cooling Solar Ventilation Preheating

5.4 Summary of Recommended Technology Development Initiatives

Based on our review of the 17 priority technologies, we recommend that DOE and industry stakeholders focus on the 13 recommended initiatives outlined at the end of this subsection. Advancing these technology options to commercialization and greater industry practice will reduce commercial HVAC natural gas and electricity consumption in the U.S. Figure 5-3 lists the 17 priority technology options, sorted by technical maturity and designated with one of three lead organizations.

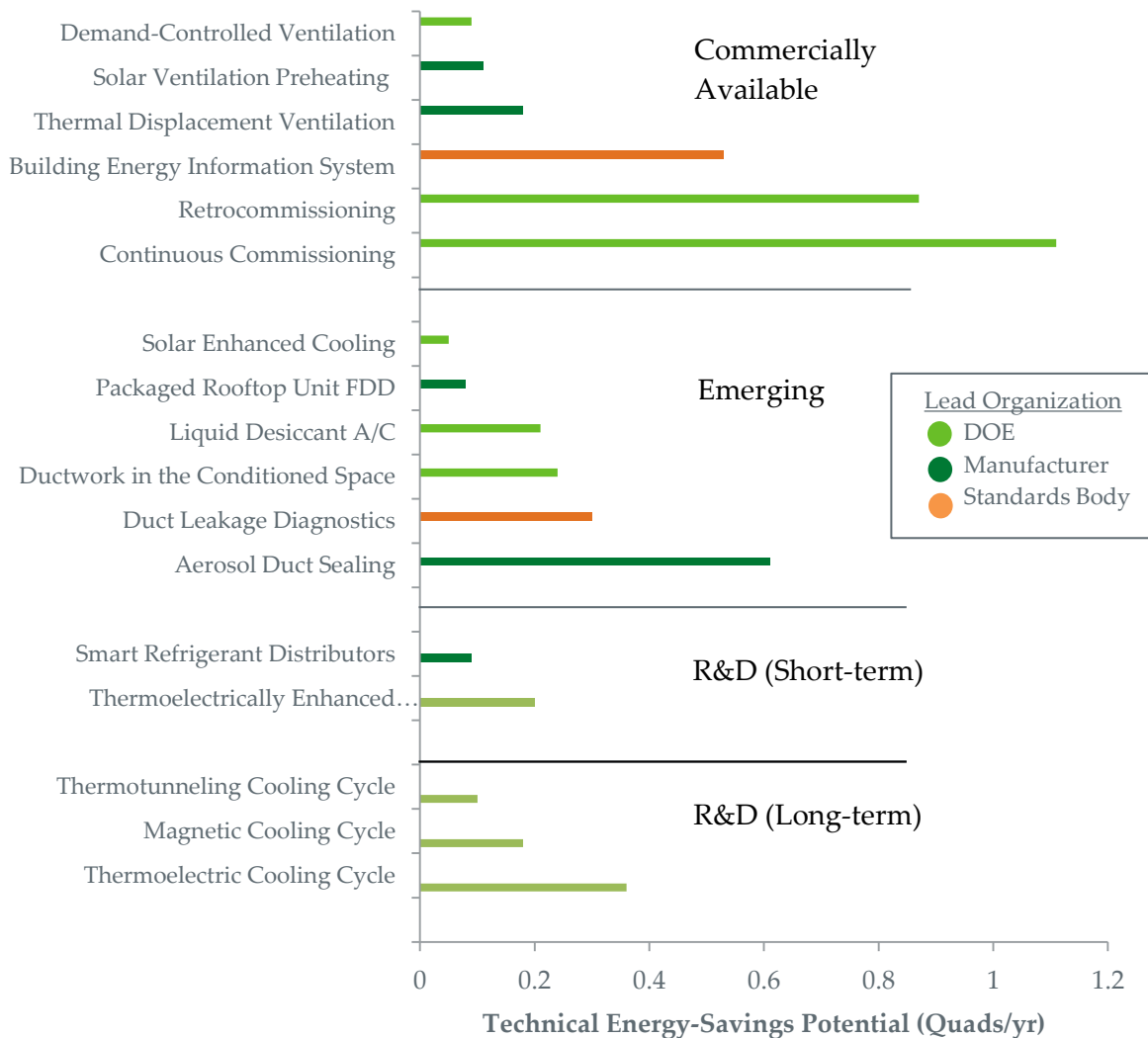

Figure 5-3: Recommended Lead Organizations for Advancement of the Final Priority Technology Options

We assume that DOE, in conjunction with other stakeholders, will have a large role in supporting basic research and development of immature technologies, while manufacturers and industry organizations (e.g., standards bodies) will have primary roles in demonstrating, refining, and

supporting emerging and available technologies. While we suggest a lead organization for each initiative, many of these initiatives will require collaboration among the various industry stakeholders, including building owners. For mature technologies, we suggest that DOE has a role in developing resources for collecting and sharing of information, in funding research of further design options, and in shaping incentive programs. We also suggest that manufacturers, industry organizations, and utilities have an equally large role in shaping the development of these technologies. For systems based on sensor technology and software, we see development of consensus standards as the greatest need, and this is most appropriate for standards bodies.

5.4.1 Summary of Recommended DOE-Led Initiatives

Early Stage Technologies

Section 4 identifies eight technology options in the early stages of R&D for which there was a paucity of publicly available information. These innovative technologies show potential, but need R&D support to understand their applicability for commercial HVAC systems. Because we were unable to reliably evaluate their unit energy savings, we recommend that DOE conduct independent testing and monitor the development of these technology options. If the results of testing are promising, DOE should support ongoing R&D efforts for these technologies.

R&D Stage Technology Options

I. Support development of advanced high-ZT materials and low work-function materials

Applicable Technology Options: Thermoelectric Cooling Cycle, Thermoelectrically Enhanced Subcoolers

The low efficiency of current thermoelectric materials has been a major obstacle for the development of thermoelectric systems. We recommend that DOE support basic material science research and nano-scale engineering research that aims to advance material properties. This includes research on nano-scale material structures that can greatly enhance the electrical properties that may lead to development of new thermoelectric material beyond what are currently used today. It also includes research on high-ZT thermoelectric materials for both localized cooling (e.g., thermoelectrically enhanced subcoolers) and centralized cooling equipment (i.e., application of thermoelectric cooling cycle to the cooling plant of a central air-conditioning equipment).

II. Support development of designs reducing the use of rare-earth metals

Applicable Technology Options: Magnetic Cooling Cycle, Thermoelectric Cooling Cycle, Thermoelectrically Enhanced Subcooler, Thermotunneling Cooling Cycle

Alternative cooling systems such as magnetic cooling rely on expensive, rare-earth metals to power key magnetic components. We recommend that DOE support research of alternative designs that reduce or eliminate dependence on rare-earth metals while preserving current levels of system efficiency.

III. Support development of improved manufacturing strategies for small-scale, advanced-material technologies

Applicable Technology Option(s): Magnetic Cooling Cycle, Thermoelectric Cooling Cycle, Thermoelectrically Enhanced Subcooler, Thermotunneling Cooling Cycle

Advanced cooling-cycle technologies require new fabrication techniques to reduce production costs and increase their commercial viability. Manufacturers have not identified any suitable manufacturing methods for reliable large-scale production of these technologies. Manufacturers produce prototypes using manufacturing techniques based on semiconductor production strategies; however, the strategies are not optimized to the materials and designs used by these technologies. New materials possess different material properties from conventional semiconductor manufacturing materials; they usually require different bonding and shaping techniques. We recommend that DOE support research on alternative manufacturing strategies that are optimized to both the small-scale of the technologies and the advanced materials being used. In addition, we recommend DOE to evaluate larger-scale manufacturing concepts to help project the ultimate cost of manufacturing commercial HVAC systems using advanced cooling cycles.

Emerging and Commercially Available Technology Options

- I. Conduct long-term field studies on alternative ventilation strategies***
Applicable Technology Options: Demand-Controlled Ventilation, Thermal Displacement Ventilation

The alternative ventilation strategies of demand-controlled and thermal-displacement ventilation have been shown to save energy in certain commercial applications (particularly buildings having low occupancy during peak hours). To better understand the capabilities of these technologies, we recommend that DOE conduct field testing across a variety of locations, building types, system designs, etc. The chosen buildings should undergo long-term monitoring to help quantify the non-energy benefits in addition to any energy savings. The goal of these nationwide field studies is to identify the most promising applications of alternative ventilation strategies in the U.S. and facilitate integration with building simulation software for modeling of future projects.

- II. Support development of strategies to facilitate assessment of airflow and thermal efficiency of ducts***
Applicable Technology Options: Aerosol Duct Sealing, Duct-Leakage Diagnostics, Ductwork in the Conditioned Space

HVAC duct leakage contributes to increased fan usage and wasted thermal energy. Although duct leakage is a systemic problem in many HVAC systems, strategies to quickly identify and remediate duct leakage are underdeveloped, especially for complex duct systems. Duct-leakage diagnostics and aerosol sealing systems depend on methods to quickly and accurately evaluate the state of a duct system. Because of the substantial time and equipment costs associated with identifying and repairing leaky ducts, we recommend that DOE conduct a comprehensive study of the U.S. commercial building stock to identify which building types could improve most through duct-leakage remediation. We also recommend that DOE support development of

standards, sensor systems, and strategies for evaluating airflow and thermal efficiency in commercial duct systems.

III. Support further refinement of the energy economics for performance optimization and diagnostics technologies

Applicable Technology Options: Building Energy Information System, Continuous Commissioning, Packaged Rooftop Unit FDD, Retrocommissioning

As seen in **Figure 5-2**, performance optimization and diagnostics technologies, listed above, have an enormous potential to reduce HVAC energy consumption (>0.25 Quads/yr). These technologies save both electricity and natural gas across most building types and climate regions. Energy savings can vary widely depending on whether a building’s HVAC system is operating as designed or whether its performance has fallen off significantly over time. To help remove uncertainty, we recommend that DOE create a database of successful projects demonstrating the capabilities of these strategies to building owners. By providing better estimations of upfront costs, energy savings, and non-energy benefits, these DOE actions should alleviate much of the decision makers’ initial hesitation, and lead to wider commercialization for these technologies.

IV. Develop greater understanding of real-world energy performance for HVAC equipment and systems over their lifetime

Applicable Technology Options: Building Energy Information System, Continuous Commissioning, Packaged Rooftop Unit FDD, Retrocommissioning

Technologies in this category optimize and maintain energy performance over the life of the building’s HVAC system. These technologies identify inefficiencies by benchmarking trends against expected performance levels. Understanding how equipment aging affects system operations and energy consumption leads to more accurate baseline performance and efficiency models. We recommend DOE to support research to better assess the real-world performance of HVAC systems as they age. The analysis should be based on collect operational data through both laboratory testing and long-term field testing of existing systems, and focus on specific equipment (e.g., a chiller rather than the entire cooling system) over its operational life. The results of this testing would correlate the effects that various degrees of directed maintenance have on equipment energy consumption and expected operational duration. Understanding which system problems lead to decreased equipment lifetimes helps users prioritize their maintenance strategies. The insights gained from this study could improve the benchmarking capabilities of performance optimization and diagnostics systems as well as establish baselines for lifetime building energy standards.

5.4.2 Summary of Recommended Manufacturer-Led Initiatives

I. Develop techniques for cost-effective integration of component technologies into existing systems

Applicable Technology Options: Smart Refrigerant Distributors, Thermoelectrically Enhanced Subcoolers

The largest opportunity to reduce building energy consumption comes from retrofitting existing building equipment to increase its efficiency, as opposed to improving the efficiency of equipment for new construction. However, retrofitting existing systems can be costly and labor-intensive, and typically require specialized equipment. We recommend that manufacturers investigate component designs and installation strategies that minimize the cost burden and inconvenience on building owners and tenants. This investigation could extend to the system level; for example, a modular system that allows for rapid exchange of key components.

II. Conduct demonstrations of, and publish field data for, advanced components using a variety of refrigerant types and equipment designs

Applicable Technology Options: Smart Refrigerant Distributors, Thermoelectrically Enhanced Subcoolers

Documentation of successful and reliable installations will reduce the uncertainty associated with these technologies, which is a key barrier in accelerating the adoption of these technologies. We recommend that manufacturers conduct extensive demonstrations of these components in existing equipment to establish their viability in the retrofit market.

III. Optimize the capabilities and number of sensors for performance optimization and diagnostics systems

Applicable Technology Options: Building Energy Information System, Continuous Commissioning, Packaged Rooftop Unit FDD, Retrocommissioning

Each technology option in this category reduces energy consumption over time by utilizing sensor information that measures HVAC system operations and conditions. We recommend that manufacturers develop strategies that supply the needed information more effectively at lower cost. Offering sensors having self-identifying capabilities or systems that link multiple sensors over a wireless network can reduce installation costs. We also recommend that manufacturers determine which HVAC components and state conditions are the leading indicators for inefficient performance and then develop algorithms that provide the necessary monitoring and benchmarking capabilities using fewer sensors. Creating a better monitoring network using an optimal number of sensors and advanced software algorithms should reduce installation costs and spread the use of these technologies.

5.4.3 Summary of Recommended Industry Organization-Led Initiatives

I. Incorporate duct-leakage prevention and best practices into future building standards and codes

Applicable Technology Options: Aerosol Duct Sealing, Duct-Leakage Diagnostics, Ductwork in the Conditioned Space

Because of their unique position to communicate with HVAC technicians and building operators across the country, HVAC industry organizations can compile information and best practices from the field. We recommend that these organizations conduct training seminars on the latest prevention, detection, and repair methods to increase awareness of this common commercial

building problem. Creating building standards that encourage placement of ducts in the condition space and duct-leakage testing upon installation would widen its practice in industry. Building certification programs could award points in their ratings for benchmarking a building's duct leakage.

II. *Establish industry standards for fault detection and diagnostics systems*
Applicable Technology Options: Building Energy Information System, Continuous Commissioning, Packaged Rooftop Unit FDD

Fault detection and diagnostics systems use the accurate identification of system malfunctions or trends of poor efficiency to alert the need for directed maintenance. Although various FDD methods exist to find faults, we recommend that industry establish common terminology and standards for fault thresholds to facilitate interoperability across the HVAC industry. The success of FDD systems, especially for packaged equipment, depends on eliminating potential false alarms and easily identifying faults. Creating these standards allows field technicians to read and repair faults more quickly, and increases compatibility across the multiple levels of automated systems and controls. Terminology standards foster industry-wide understanding of FDD's benefits and capabilities while providing a platform to share best practices.

5.4.4 *Summary of Recommended Utility Initiatives*

I. *Offer incentives to decrease the upfront costs of performance optimization and diagnostics systems*
Applicable Technology Options: Building Energy Information System, Continuous Commissioning, Packaged Rooftop Unit FDD, Retrocommissioning

To achieve wider practice in industry, we recommend strategies to lessen the uncertainty of potential energy-savings impacts and the expected payback for decision makers. While other industry stakeholders should focus their efforts on improving the estimation of energy savings, gas and electric utilities should offer incentive programs that reduce the upfront cost of these technologies. For example, rebates could cover a portion of the cost for a retrocommissioning study or the associated premium of packaged equipment with FDD capabilities. Because of their potential for significant peak-demand reduction and overall energy savings, an incentive program of this type would provide value to the utility's service territory.

References

Note: References cited in In-Depth Analyses of the Final Priority Technologies (Section 3) are listed at the end of each analysis write-up.

Brodrick, James. 2000. "Are Fans Blowing Your Energy Budget?" HPAC Heating/Piping/Air Conditioning Engineering. December, 2000. P 74-77.

NCI, 2009. *Energy Savings Potential and R&D Opportunities for Commercial Refrigeration* Prepared for the Building Technologies Program, US DOE. September 2009.

Roth, K., Goldstein, F., and Kleinman, J., 2002. *Energy Consumption by Office and Telecommunications Equipment in Commercial Buildings – Volume I: Energy Consumption Baseline*. Report for the DOE Office of Building Equipment, Office of Building Technology State and Community Programs. January.

US Department of Energy (US DOE), 2005. *2003 Commercial Building Energy Consumption Survey*.

US DOE, 2011. *2011 Building Energy Databook*. November 2011.

Appendix A List of the Initial 135 Technology Options

Components (68)	Equipment (51)
Active Window Insulation	Absorption Heat Pump
Advanced Absorption Pairs	Adsorption Cooling Cycle
Advanced HID Lighting	Air to Water/Brine Heat Pump
Advanced Noise Control	Bio Filtration (Phytoremediation)
Aerosol Duct Sealing	Brayton Cooling Cycle
Airfoil-Blade Centrifugal Fan	Carbon-Dioxide Heat Pump
Ambient Subcoolers	Centrifugal Bernoulli Heat Pump
Backward-Curved Centrifugal Fan	Cold-Weather Heat Pump
Better Insulation of Heaters/Chiller	Combined Heat and Power (mCHP)
Better Pipe Insulation	Condensing Gas or Oil Boilers/Furnaces
Brushless DC Motors	DEVap A/C
Carbon-Dioxide Refrigerant	Dual-Compressor Chillers
Commercial Roof Coloring	Dual-Fuel Heat Pump
Copper Rotor Motor	Dual-Source Heat Pump
Disk Permanent Magnet Motors	Dual-Stirling Engine Heat Pump
Doubly-Salient Permanent Magnet Motors	Ejector Heat Pump
Electrohydrodynamic Heat Transfer Enhancement	Electrochemical Pump Heating/Cooling
Enhanced Swirl Furnaces	Electrostatic Filter
Evaporative Condensers	Engine-Driven Heat Pump
Fans Optimized for Every Application	Enthalpy Heat Wheel
Heat Pipes	Evaporative Cooling
HFO Refrigerants	Evaporative Precooling
High-Performance Windows ($U < 0.25$)	Ground Source Heat Pump
High-Quality Building Insulation	Helmholtz Pulse Combustion Furnace
High-Temperature Superconducting Motors	High-Efficiency R744 Centrifugal Chiller
Hydrocarbon Refrigerants	Hot-Dry Air-Conditioner
Inlet Guide Vanes	Hybrid Chillers
Integrated Skylight Illuminaire	Improved-Efficiency Oil Burner
Interior Duct Insulation	Kitchen Ventilation Heat Recovery
Larger Duct Cross-Sections	Liquid Desiccant Air-Conditioner
Lower dP Diffusers	Low-Temp Absorption Chillers
Lower dP Terminal Boxes	Low-Temp Vapor Compression
Metal Foam Heat Exchanger	Magnetic Cooling Cycle
Microchannel Heat Exchanger	Mechanical Subcooler
Nanofluids Enhanced Twisted Tape Heat Exchanger	Membrane Humidity Control w Advanced Active Desiccant Materials
Nanofluid Refrigerant Additives	Modulating Boiler/Furnace

Optimize Cooling Tower Airflow	Multistage HP
Optimized Heat Exchangers	Ozone Air Treatment
Part-Load Staged Compressors	Plasmacutter Ion Air Purifier
Passive Unsteady Airflow Mechanisms	Pulse-Tube Compressor
Polymer/Metal Hybrid Heat Exchanger	Runaround Recovery Coils
Premium Lubricants	Solar Enhanced Cooling
Refrigerant Pump to Reject Compressor Heat Directly to Condenser	Tankless Water Heater for Radiant
Rotary Screw Compressors	Thermoacoustic Cooling Cycle
Screw Compressor w/ Vapor Injection	Thermoelastic Cooling Cycle
Smaller Centrifugal Compressors	Thermoelectric Cooling Cycle
Small-Grooved Copper Tubes	Thermotunneling Cooling Cycle
Smart Refrigerant Distributors	Triple-Effect Absorption Chillers
Smooth Duct Section Connections	UV Outdoor-Air Treatment
Smooth Duct Transitions	Vortex-Tube Cooling Cycle
Stirling Subcooling	Vuillimier Cooling Cycle
Swing/Rolling Piston Compressors	
Switched Reluctance Motors	Systems (37)
Thermoelectrically Enhanced Radiators	3D BIM / Energy Modeling
Thermoelectrically Enhanced Subcoolers	Active Thermal Energy Storage
Turbo-Compressor-Condenser-Expander	Air-Side Economizer
Twin-Single Compressors	All-Natural Ventilation
Two-Speed Motors	All-Water vs. All-Air Thermal Distribution Systems
Two-Way Valves in Chillers	Baopt Pulse Cooling System
Use Larger Fan Blades	Chilled Beam Radiant Cooling
Use Low-Friction Pipes	Chilled Water Economizer
Variable pitch fans	Data Center Chilled Water Racks
Variable-Stroke Compressor / Bowtie Compressor	Daylighting Strategies
VFD/Motor Grounding Bearings	Dedicated Outdoor Air System
Water-Cooled Condensers for Unitary Equipment	Demand-Controlled Ventilation
Winglets for Fans	District Heating/Cooling
Written-Pole Motors	Ductless Split-Systems
Zephyr Ceiling Tiles	Ductwork in the Conditioned Space
	Eliminate Balance Valves in Chilled Water Loops
Operations/Maintenance (20)	Eliminate Series Fan Boxes
Chemical Water Treatment	Evaporative Roof Cooling
Complete Commissioning	Floating Head-Pressure in Large DX systems
Continuous Commissioning	Giant Fan Ventilation/Cooling

Damper FDD	In-Room Zonal Radiant Heating/Cooling
Duct Static Pressure Reset and Control	Low-Lift Chilled Water System
Duct-Leakage Diagnostics	Mini-Duct System
Electron-Beam Water Treatment	Mixed-mode Conditioning
Electrostatic Water Treatment	Modular Chillers and Boilers
Magnetic Water Treatment	Night Sky Rooftop Radiant Cooling
Multilevel FDD	Optimize Condenser Water Pump Size
Occupant Education	Passive Thermal Energy Storage (Phase Change Ceiling / Insulation)
Optimizing Thermostat Behavior	Proper Alignment of Fans/Ducting
Ozone Water Treatment	Seasonal Thermal Energy Storage
Packaged Rooftop Unit FDD	Shading Condenser Coils
Reduced/Zero Maintenance Design	Solar Ventilation Preheating
Regular Maintenance	Solar-Assisted Mechanical Systems
Retrocommissioning	Thermal Displacement Ventilation
Submetering loads	Unitary Thermal Energy Storage System
UV Water Treatment	VRV/VRF
Whole Building Diagnostics	Water-loop HP System (California Loop)
Controls (6)	
Building Automation System	
Building Energy Information System	
Direct Digital Control	
Electronic Expansion Valves	
Microenvironments	
Variable-Speed motors	

Appendix B Preliminary Analyses

As discussed in Section 2.3, we performed a preliminary analysis of technical energy-savings potential and potential next steps toward greater market adoption for each of the 57 technology options we selected after the first round of screening. Of these 57 technology options, we performed in-depth analyses for 17 priority technology options (Section 3), and presented summary write-ups for eight technology options that are still in the early stages of R&D (Section 4).

This section includes the preliminary analysis write-ups for the remaining 32 technology options, organized in alphabetical order, as presented in **Table B-5-5**.

Table B-5-5: 57 Technology Options Selected for Preliminary Analysis

Advanced Absorption Pairs	Modular Chillers and Boilers
Airfoil-Blade Centrifugal Fan and Blowers	Multilevel FDD
Chilled Beam Radiant Cooling	Nanofluids Enhanced Twisted Tape Heat Exchanger
Cold Weather Heat Pump	
Copper Rotor Motor	Optimized Heat Exchangers
Damper FDD	Passive Unsteady Airflow Mechanisms
Dedicated Outdoor Air System	Permanent Magnet Motors
Dual-Source Heat Pump	Regular Maintenance
Duct Static Pressure Reset and Control	Seasonal Thermal Energy Storage
Electrohydrodynamic Heat-Transfer Enhancement	Smaller Centrifugal Compressors
Fans Optimized for Every Application	Small-Grooved Copper Tubes
High-Temperature Superconducting Motors	Switched Reluctance Motors
Hot-Dry Air-Conditioner	Triple-Effect Absorption Chillers
Membrane Humidity Control with Advanced Active Desiccant Materials	Thermal Energy Storage System in RTU
	Variable-Pitch Fans
Microchannel Heat Exchangers	VRV/VRF
Mixed-mode Conditioning	Water-Cooled Condensers for Unitary Equipment

B.1 Advanced Absorption Pairs

Systems Impacted by Technology		Energy-Savings Performance	Technical Maturity
Absorption Chillers		0.01 Quads/yr	R&D(long-term)
Peak-Demand Reduction Potential	Non-Energy Benefits	Ease of Retrofit	Cost/Complexity
Low	Uses Low-quality Heat	High	Medium

Description of Technology

Absorption chillers rely on the chemical and thermodynamic properties of working fluid pairs to supply cooling from a heating source. Ammonia-water ($\text{NH}_4 - \text{H}_2\text{O}$) and water-lithium bromide ($\text{H}_2\text{O} - \text{LiBr}$) pairs have been used as the primary working fluids for decades. In an effort to utilize lower quality heating sources, the use of absorption cooling can expand through development of advanced absorption pairs. Ammonia-lithium nitrate ($\text{NH}_4 - \text{LiNO}_3$), R134a-DMAC, and lithium bromide-sodium formate ($\text{LiBr} - \text{CHO}_2\text{Na}$) are among others that have been shown to provide an efficiency advantage over conventional working fluids for certain applications.

Description of How Technology Saves Energy

Low-quality heating sources consist of low-temperature steam or hot water and can drive certain absorption chiller designs, although with limited capacity. Low-quality heat produced from industrial, solar, or geothermal sources can offset the lower COP of absorption chillers. The characteristics of the working fluid can be optimized for these low-quality heating sources beyond the capabilities of traditional $\text{NH}_4 - \text{H}_2\text{O}$ and $\text{H}_2\text{O} - \text{LiBr}$ pairs. Developing chemical pairs with lower vapor pressure, crystallization temperature, and latent heat of absorption offer operational and economic advantages. The advanced absorption pairs produce higher COPs at the temperatures provided by the low-quality heating sources.

Potential for Retrofit

This technology will be included in high efficiency replacement equipment. Due to the nature of absorption chillers, the advanced working pairs cannot be substituted on existing equipment.

Potential Scope of Impact

Absorption chillers with novel working fluids will replace conventional absorption equipment when the opportunity exists. The conventional absorption pairs will still provide superior performance with high quality heat sources. The advanced absorption chillers will primarily replace direct expansion vapor compression chillers or packaged equipment where there is an appropriate low-quality heating source. Based on an analysis of its potential impact on HVAC systems in the U.S., this technology would save 0.01 Quads of electricity per year.

Energy-Savings Performance

Crepinsek et al. (2000) investigated a number of alternative absorption pairs and determined that $\text{NH}_4 - \text{LiNO}_3$ has an 8-10% increase in efficiency for single-effect systems. For half-effect

systems, R134a-DMAC increased efficiency by as much as 50% and for double-effect systems, TFE-TEGDME has an increase of 15%.

Lucas et al. (2007) found that LiBr – CHO₂Na had a better absorption capacity at low-temperatures increasing system COP up to 10%.

Abdulateef et al. (2007) proposed that NH₄ – LiNO₃ was comparable to conventional absorption pairs and provided better performance for low-quality heat sources.

Cost Information

Absorption chillers have a higher first cost compared to vapor compression equipment, but become economically advantageous where there is a low-cost heating source or high electricity rates. The cost of advanced pairs as absorption working fluids is unknown at this time.

Peak-Demand Reduction and other Benefits beyond Energy-Efficiency Gains

Advanced absorption pairs increase the efficiency of systems utilizing low-grade heat provided by solar, geothermal or waste sources. Absorption cooling has high reliability with low maintenance requirements.

Technical Maturity and Recent Developments

This technology is not commercially available, with a few significant technical issues that requires long-term R&D efforts before they are resolved. Research into the chemical and thermodynamic properties of advanced pairs has found a number of viable alternatives. Computer modeling has shown at least theoretically that these absorption pairs could work in absorption chillers driven by low-quality heat.

Barriers to Market Adoption

The absorption chiller is designed specifically around its working fluid pairs. Introducing alternate absorption pairs greatly changes the cooling cycle and will require entire system redesign to take advantage of their improved efficiencies. The significant research and development costs needed for such an overhaul might outweigh any added benefit over currently available technology.

Opportunities and Next Steps for Technology

Research into the material characteristics of advanced absorption pairs will continue to identify promising working fluids that reduce some of the drawbacks of current pairs. The new working fluid pairs need to be introduced in a laboratory chiller to see how they react over time with other chiller components. A thorough market assessment will determine whether the advanced pairs continue to the product development phase. Although holding limited market share today, rising electricity prices make absorption cooling with and without advanced pairs more attractive.

References

Abdulateef et al. 2007. “Solar Absorption Refrigeration System Using New Working Fluid Pairs.” International Journal of Energy. Issue 3, Vol. 1, 2007. p 82-87.

Crepinsek et al. 2000. "Comparison of the Performances of Working Fluids for Absorption Refrigeration Systems." Proceedings of the 3rd WSEAS Int. Conf. on Energy Planning, Energy Saving, Environmental Education. p 59-64.

Etatech, Inc. 2006. "Waste Heat Powered Absorption Cycle Compressor." Retrieved from <http://etatech.us/>.

Lucas et al. 2007. "Absorption of Water Vapor into New Working Fluids for Absorption Refrigeration Systems." Industrial & Engineering Chemistry Research. Vol. 46, No.1, 2007. p 345-350.

Mittal et al. 2005. "The Study of Solar Absorption Air-Conditioning Systems." Journal of Energy in Southern Africa. Vol. 16, No. 4. November 2005. p 59-66.

Wang and Chua. 2009. "Absorption Cooling: A Review of Lithium Bromide-Water Chiller Technologies." Recent Patents on Mechanical Engineering 2009. Vol. 2, No.3. p 193-213.

B.2 Airfoil Blade Centrifugal Fans and Blowers

Systems Impacted by Technology		Energy-Savings Performance	Technical Maturity
Forced Draft Blowers		0.06 Quads/yr	Comm. Available
Peak-Demand Reduction Potential	Non-Energy Benefits	Ease of Retrofit	Cost/Complexity
Low	Noise Reduction	High	Medium

Description of Technology

Centrifugal fans and blowers are the primary movers of air in packaged commercial HVAC systems. Fan blades in centrifugal equipment either angle forward to the direction of rotation or backward against it. Forward curved blades usually are used in residential HVAC systems with lower first cost and limited performance capabilities. Backward curved fan blades typically rotate twice as fast as forward curved blades and come in either flat, curved, or airfoil blade shapes. For clean air HVAC situations, airfoil blade centrifugal fans provide more efficient performance with lower discharge noise.

Description of How Technology Saves Energy

Airfoil blades have variable thickness in their cross section (chord) for better aerodynamic properties. Although many airfoil shapes used in industry, the improved lift and drag characteristics of airfoils reduce rotational losses. All backward curved blowers provide highly efficient airflow expansion in forced draft systems. When coupled with airfoil blades, reductions in motor power requirements and heat transfer losses to cooled air from the rotational energy raise overall system performance.

Potential for Retrofit

Airfoil blade centrifugal blowers could be individually retrofit into large commercial systems, or as a component in high-efficiency packaged replacement equipment.

Potential Scope of Impact

All commercial HVAC forced draft blowers would benefit if the airflow is clean. Grease and dust accumulates on centrifugal fans and debris can damage the precise airfoil shape. Based on an analysis of its potential impact on HVAC systems in the U.S., this technology would save 0.06 Quads of electricity per year.

Energy-Savings Performance

UNEP (2006) stated that airfoil blade centrifugal fans have static efficiencies of 79-83%, which is a 20% improvement over forward curved fans, and 10% over axial fans.

Kostromitin (2009) found that airfoil blades have efficiencies of 87-92% translating to a 5% improvement over other backward curved blades.

Total HVAC energy savings will depend on each particular system and its fan requirements.

Cost Information

Higher manufacturing costs for the airfoil blades result in higher costs for this technology across the industry.

Twin City Fans and Blowers estimates a 2% price premium over standard backwards curved blowers.

Peak-Demand Reduction and other Benefits beyond Energy-Efficiency Gains

The improved aerodynamics of the airfoil blades reduce system noise.

Technical Maturity and Recent Developments

This is a commercial available technology with many manufacturers offering backwards curved airfoil blowers.

Barriers to Market Adoption

This technology is limited by its higher first cost and its impracticality with dirty or hazardous airstreams.

Opportunities and Next Steps for Technology

Large commercial office buildings with relatively clean airflow will benefit most from blowers with airfoil blades. Applying the aerodynamic curving to other sections of the blower will also increase efficiency.

References

Chicago Blower Corporation. "SQA Centrifugal Fans." Bulletin SQA 108.

Kostromitin, Vitaliy. 2009. "Efficient Fan Blades." Oregon State University. Energy Efficiency Center.

Twin City Fans and Blowers. "BC & BAF SWSI Backward Inclined and Airfoil Fans." Bulletin 300.

U.S. Department of Energy. 2003. "Improving Fan System Performance – A Sourcebook for Industry." U.S. Department of Energy. Office of Energy Efficiency and Renewable Energy. DOE/GO-102003-1294. April 2003

United Nations Environmental Programme. 2006. "Electrical Energy Equipment: Fans and Blowers." Energy Efficiency Guide for Industry in Asia.

B.3 Chilled Beam Radiant Cooling

Systems Impacted by Technology		Energy-Savings Performance	Technical Maturity
VAV or other Cooling Systems		0.04 Quads/yr	Comm. Available
Peak-Demand Reduction Potential	Non-Energy Benefits	Ease of Retrofit	Cost/Complexity
Medium	IAQ/Comfort	Medium	Medium

Description of Technology

For commercial buildings that would typically use a ducted VAV system, chilled beam radiant cooling offers many design advantages. Chilled water flows directly into specialized ceiling panels that use convection and radiative heat transfer to cool a room with a separate dedicated outdoor air system (DOAS) for ventilation. A passive chilled beam panel consists of only piping and fins where an active system uses ventilation air to distribute the cooling from the panel to the surrounding air. In this way, sensible cooling is separated from ventilation, raising system efficiency and reducing the size of other HVAC equipment.

Description of How Technology Saves Energy

Since a radiant cooling system does not require air delivery to condition spaces, it reduces fan energy consumption. Chilled water has a much higher capacity than air so pumping energy is significantly less than the equivalent energy for air movement. Chillers can be sized smaller and supply water at a higher temperature reducing energy consumption. The system could achieve further energy savings through the use of chilled water economizers or a geothermal ground loop.

Potential for Retrofit

Chilled beam cooling systems are readily retrofitted into large commercial buildings that use chilled water systems. Sachs et al. (2009) estimates that combined with new constructions, 27% of US office space would be ready for installation of a chilled beam system.

Potential Scope of Impact

Chilled beam systems would replace conventional VAV cooling systems in appropriate building types. Based on an analysis of its potential impact on HVAC systems in the U.S., this technology would save 0.04 Quads of electricity per year.

Energy-Savings Performance

Sachs, et al. (2009) estimate that a radiant heating/cooling system would reduce energy consumption by approximately 20% compared to a standard VAV system.

Alexander and O'Rourke (2008) discussed various design considerations for chilled beam cooling and found that building HVAC usage could be reduced by >40% once accounting for smaller equipment sizing.

Cost Information

Sachs, et al. (2009) estimates the installation cost savings of 5% compared to a typical VAV HVAC system installation. Incremental cost according to the recent experiences listed by the study ranges from a 16% savings to a 15% cost premium for chilled beam projects.

Costs will vary with application, especially for new construction. The chiller, ductwork, air handlers etc. can all be downsized with the use of chilled beams. Because of their slim profile, this technology reduces the amount of ceiling space needed for HVAC systems. Chilled beams also require separate heating and ventilation systems which can increase costs.

Peak-Demand Reduction and other Benefits beyond Energy-Efficiency Gains

In cases where the chiller size can be decreased, peak demand will decline as well. Radiant cooling is considered to be more comfortable and quiet compared to conventional forced air systems.

Technical Maturity and Recent Developments

This is a commercial available technology.

Barriers to Market Adoption

The application of chilled beam cooling is limited by both high latent and sensible cooling demands. Condensation on the chilled beam is an issue, but can be mitigated by controlling humidity levels and keeping indoor dew-point temperatures below that of the chilled water. Sealed building envelopes are required to reduce outdoor air infiltration and maintain humidity control. Rooms with high ceilings like atriums or who have high humidity levels such as health clubs should not use chilled beams. Areas with high cooling loads, $>70 \text{ W/m}^2$ for passive and $>160 \text{ W/m}^2$ for active beams, would lose the effectiveness of the chilled beam system design.

Opportunities and Next Steps for Technology

The use of chilled beam cooling will rise in the U.S. for its many benefits to system designers and occupants. More analysis should be done on the existing buildings with chilled beams, especially in various building types and climates. The lifecycle benefits including smaller equipment, reduced operational costs, and lower maintenance requirements should be studied further to provide better comparison with VAV systems.

References

Alexander and O'Rourke. 2008. "Design Considerations for Active Chilled Beams." ASHRAE Journal. September 2008. p 50-58.

Roth et al. 2007. "Chilled Beam Cooling." ASHRAE Journal. September 2007. p 84-86.

Rumsey and Weale. 2007. "Chilled Beams in Labs." ASHRAE Journal. Vol. 49, Jan. 2007. p 18-25.

Sachs et al. 2009. "Emerging Energy-Saving HVAC Technologies and Practices for the Buildings Sector (2009)". ACEEE Report Number A092.

Virta, M. 2005. “Modern air distribution systems in occupied spaces for better energy efficiency and indoor environment”. REHVA Workshops at Clima at Lausanne, Switzerland: October 10-12, 2005.

B.4 Cold Weather Heat-Pump

Systems Impacted by Technology		Energy-Savings Performance	Technical Maturity
Packaged HVAC Systems in Cold Climates		0.06 Quads/yr	Emerging
Peak-Demand Reduction Potential	Non-Energy Benefits	Ease of Retrofit	Cost/Complexity
None	None	Medium	Medium

Description of Technology

Air-source heat pumps are typically installed and operated in regions with warmer climate. However, there are technology providers that are developing heat pump systems that can operate economically in cold climate conditions by enhancing the heat pump performance through advanced controls and the use of two-stage compressors and an auxiliary compressor that come on to increase capacity once the outside temperature falls below a certain threshold [Sachs, et al. (2009)].

Description of How Technology Saves Energy

One such product offered by Hallowell International, the Acadia, uses a unique two-cylinder compressor. The compressor operates on one cylinder during mild weather. When outside temperatures drop to approximately 42°F, the compressor reverses rotation and both cylinders operate to increase the displacement and volumetric flow. As outside temperature continues to fall, below about 30°F, a booster compressor comes on to further increase capacity. Advanced controls and programmable thermostat optimizes compressor performance and controls back-up resistance heat.

Other features of the Acadia that improves its performance in cold climate are the use of economizer and the use of specially designed outdoor coil. An economizer sub-cools the warm liquid from the condenser before it reaches the evaporator, which increases the ability of the refrigerant to absorb energy from the cold outside air. The outdoor coil used in the Acadia is designed to reduce the rate of moisture build-up on its surface, which reduces defrost losses when compared to a standard air-source heat pump.

Potential for Retrofit

This technology would replace new or existing packaged HVAC equipment in cold weather climates.

Potential Scope of Impact

Packaged HVAC systems that would typically use vapor compression cooling and gas heating would be impacted by the introduction of cold weather heat pumps. Based on an analysis of its potential impact to HVAC systems in the U.S., this technology would save .048 Quads of natural gas, and .015 Quads of electricity per year.

Energy-Savings Performance

According to Sachs, et al. (2009), the estimated energy savings is 26%.

Cost Information

EnergyIdeas (2007) reports that the installed cost of a cold weather heat-pump system is in the range of \$8,000 to 12,000, including ducting, which suggests that the cost premium over a standard, conventional heat pump is in the range of \$3,000 to \$4,000 per installation. However, a more detailed breakdown of installed cost is not publicly available due to the reluctance of the manufacturer and distributor to disclose the cost information.

Similarly, Sachs, et al. (2009) reports that Washington State University estimated a premium of \$3000-4000, and Bonneville Power Association estimated \$2000 in separate studies.

Peak-Demand Reduction and other Benefits beyond Energy-Efficiency Gains

Cold Climate Heat Pumps don't use resistance heating to supply heat, thus avoiding very large peak-demand loads that occur at times of peak heating. Resistance heating is very expensive, and imposes large loads [Sachs, et al. (2009)].

According to the manufacturer, the Acadia provides “a more pleasant heat than normal air source systems, which typically deliver temperatures in the 85°F to 100°F range.” It also requires less maintenance, since the compressor has a split-capacity it operates at a reduced load for longer periods of time than a standard air-source heat pump. This reduces the number of stops and starts, which should reduce wear and tear on the equipment. Other non-energy benefits include smaller unit size and reduced noise.

Technical Maturity and Recent Developments

This is an emerging technology with limited availability in the U.S. market today. In the early 2000s, Nyle Systems started developing their “Cold Climate Heat Pump” technology for HVAC applications, but decided to switch focus to heat-pump water heaters [Stein (2006)]. Hollowell International then developed the technology into their Acadia Heat Pump and began selling the units throughout the Northeast, but went out of business in May 2011 amid the economic downturn and rising customer dissatisfaction associated with faulty controls and compressor starting circuits [Russell (2011a)]. A coalition of customers have devised a solution to overcome of these technical issues, however there is no ongoing effort to further develop this technology [Russell (2011b)].

Barriers to Market Adoption

First costs are much higher than traditional units. Furthermore, Sachs, et al. (2009) asserts that “published rating systems impede meaningful comparisons”.

Opportunities and Next Steps for Technology

Residential and Low Commercial Buildings in cold climate regions (where the temperature is below 30 °F for a significant portion of time) would benefit from this technology. Potential next steps for the technology include additional field studies to verify the performance, and further product development to reduce cost. Also, there may be opportunities to change efficiency ratings in order to increase awareness and attractiveness of the technology in the industry.

References

EnergyIdeas. “Acadia Heat Pump.” EnergyIdeas Clearinghouse – Product and Technology Review. PTR #19. December 2007.

[2011a] Russell, Eric. “NH Man has Fix for Failed Heat Pumps Made by Defunct Bangor Manufacturer.” Bangor Daily News Online. August 2011. Retrieved from <http://bangordailynews.com/2011/08/07/business/nh-man-has-fix-for-failed-heat-pumps-made-by-defunct-bangor-manufacturer/>.

[2011b] Russell, Eric. “City Official Confirms Bangor Heat Pump Firm Out of Business.” Bangor Daily News Online. May 2011. Retrieved from <http://bangordailynews.com/2011/05/24/business/auction-notice-indicates-bangor-heat-pump-firm-out-of-business/>.

Sachs, H., Lin, W., and Lowenberger, A. “Emerging Energy-Saving HVAC Technologies and Practices for the Building Sector (2009).” December 2009. Report Number A092. ACEEE.

Stein, Jay. “Will Utilities Warm Up to Low-Temperature Heat Pumps?” EnergyPulse. February 2006. Retrieved from http://www.energypulse.net/centers/article/article_print.cfm?a_id=1199.

B.5 Copper Rotor Motors

Systems Impacted by Technology		Energy-Savings Performance	Technical Maturity
Induction Motors		0.04 Quads/yr	Emerging
Peak-Demand Reduction Potential	Non-Energy Benefits	Ease of Retrofit	Cost/Complexity
Low	Longer Lifetime	High	Low

Description of Technology

For the majority of HVAC applications, induction motors are used to power fans, pumps, and compressors because of their relatively efficient performance and low first cost. They traditionally use a “squirrel cage” rotor constructed out of cheaper and more easily manufactured aluminum or steel. For years industry experts have known that using copper in the rotor would improve induction motor efficiency, but were restricted by copper’s high melting point. Traditional steel dies would fail from the high temperatures needed for copper rotor manufacturing. Recent material developments for rotor dies have made it possible to create copper rotor motors (CRM).

Description of How Technology Saves Energy

CRMs have higher efficiency due to the improved conductivity properties of copper compared to aluminum. The aluminum rotor requires fins to dissipate heat buildup from experiencing 40% higher I²R losses than the CRM. By reducing heat losses, the CRM can use less material, runs cooler, and last longer. The CRM utilizes a more efficient rotor geometry from the increased conductivity.

Potential for Retrofit

The improved CRM can be retrofit into any existing HVAC system which utilizes a traditional induction motor and will be a component of high efficiency replacement equipment.

Potential Scope of Impact

The efficiency gain of the copper rotor is small, but when factored for the operation times associated with induction motors, has a significant impact across the U.S. Based on an analysis of its potential impact on HVAC systems in the U.S., this technology would save 0.04 Quads of electricity per year.

Energy-Savings Performance

Stark et al. (2005) found a 1.4% increase in overall motor efficiency from the switch to copper rotors. They expected production efficiency increases of 1-3% after further development.

E Source (2007) summarized that the copper rotor swap would increase induction motor efficiency 1-2%.

CDA and ICA (2004) compared a CRM to an aluminum rotor model and found a 1.6% overall system efficiency improvement.

Cost Information

E Source (2007) stated that the price for the advanced CRM will depend on the variable overall price of copper and on each motor size. Large (>25 hp) motors will be less cost competitive than medium ones. On a case by case basis, CRMs may cost 10-20% more.

deFay (2010) noted that only 2% of a motor lifetime cost is reflected by the first cost. He believed that CRMs would gain market acceptance for their increased energy efficiency.

Peak-Demand Reduction and other Benefits beyond Energy-Efficiency Gains

Stark (2005) stated that because of lower operating temperatures, CRMs would have a 50% longer lifetime.

Technical Maturity and Recent Developments

This is an emerging technology with limited availability in the U.S. market today. Siemens currently sells CRM motors for HVAC in the U.S.

Barriers to Market Adoption

The fluctuating price of copper directly affects the first cost of CRMs.

Opportunities and Next Steps for Technology

CRMs like aluminum induction motors should be tested with variable speed drives and investigated for additional energy savings. CRMs are still a developing technology and additional research into the rotor geometry should maximize the specific conductivity properties of copper. Translating the die cast copper process to other critical HVAC components could raise efficiencies in other systems.

References

CDA and ICA. 2004. "Technology Transfer Report - The Die-Cast Copper Motor Rotor." Copper Development Association Inc. and International Copper Association, Ltd. Revision No. 4, April 2004.

deFay, Richard. 2010. "Benefits of the Copper Rotor Motor." Copper Development Association. Coppertalk. April 9th, 2010.

E Source. 2007. "New Motors Offer Better Performance." E Source Companies LLC.

Stark et al. 2007. "Copper in the Rotor for Lighter, Longer Lasting Motors." ASNE San Diego Section Fleet Maintenance Symposium 2005.

B.6 Damper FDD (Fault Detection & Diagnostics)

Systems Impacted by Technology		Energy-Savings Performance	Technical Maturity
HVAC Systems with Economizers or VAV Boxes		0.03 Quads/yr	Emerging
Peak-Demand Reduction Potential	Non-Energy Benefits	Ease of Retrofit	Cost/Complexity
Medium	Reduced O&M	Low	Medium

Description of Technology

Many HVAC systems rely on dampers to modulate the flow of air to correctly condition a space. Dampers in VAV boxes control the amount of heating/cooling to a space by adjusting the damper blade positioning. Air handling units (AHU) use dampers to control the mixture of return air with outdoor air (OA) and provide economizer capabilities. Damper malfunctions occur over time reducing the performance and efficiency of the HVAC system. Damper fault detection and diagnostics (FDD) is a software based strategy that senses malfunctions, and either solves the issue automatically or alerts building operators for maintenance.

Description of How Technology Saves Energy

Proper function of the damper system maintains performance and system efficiency. For example, if the OA damper is stuck fully open in winter, more heat energy is required to accommodate the increased OA volume. Poor damper operation can have cascading effects in VAV systems. A fully closed VAV damper causes fan energy use increases in that zone to provide the same conditioning and can affect performance in other areas as well. An economizer damper left open allows hot and humid air into the AHU, raising the energy consumption needed for space cooling. If the damper does fail, the FDD system alerts building managers to fix the problem before regularly scheduled maintenance. Damper FDD ensures that the system does not receive too little or too much airflow with proper control of the damper.

Potential for Retrofit

Sensors can be placed onto existing equipment, but the control algorithms require specialists to retrofit in the field. This technology will primarily be included in high-efficiency replacement equipment or building automation systems.

Potential Scope of Impact

HVAC systems which use dampers such as VAV boxes or AHUs with mixing boxes and economizers would benefit from this technology. Based on an analysis of its potential impact on HVAC systems in the U.S., this technology would save 0.009 Quads of natural gas, and 0.021 Quads of electricity per year.

Energy-Savings Performance

Roth et al. (2005) studied the use of advanced HVAC diagnostics software and found that 25-40% of systems had a damper related fault. This reduced system performance by 10-30% overall.

Miyata et al. (2005) examined faulty VAV units and attributed damper malfunctions to energy losses of 20-50%. Control of many zones was affected by the decreased performance of a single damper system. Diagnostics software was developed to identify the problematic VAV damper and reduce maintenance time and costs.

Jacobs (2003) surveyed California commercial buildings and found poor economizer operation in over 60% of equipment examined. It was estimated that California would reduce its cooling electricity use by >12% if the economizer damper were properly functioning.

Cost Information

Many manufacturers provide equipment which features microprocessor controls measuring operational characteristics of various system parts. The only additional costs to include damper FDD in future products would be the software development and training for local installers and representatives.

Peak-Demand Reduction and other Benefits beyond Energy-Efficiency Gains

Maintaining optimal damper control impacts peak demand when economizers reduce the need for conventional mechanical A/C systems. Dampers that restrict OA ventilation contribute to poor IAQ in buildings.

Technical Maturity and Recent Developments

This is an emerging technology with limited availability in the US market today. Although the prevalence of poor damper operation is known, customers do not demand FDD in equipment. Because of this, manufacturers have not included damper FDD in many of their product offerings. Numerous sample control algorithms have been developed to test damper FDD operation in the laboratory setting.

Barriers to Market Adoption

Building owners and operators lack awareness of the benefits to proper system maintenance that damper FDD software would provide. Sensors which encounter “false positives” are time consuming and lower the perception of FDD systems. FDD issues are difficult to quantify in terms of energy savings.

Opportunities and Next Steps for Technology

Buildings which use many VAV boxes or smaller packaged HVAC units would benefit most since those dampers tend to go unnoticed if malfunctioning. Economizers are required by building codes in many areas, but are often not optimized in the field. Manufacturers can implement FDD strategies in their control software to provide better system performance and longevity.

References

Cherniack, Mark. 2006. “Fault Detection and Diagnostics: Automated, Ongoing Commissioning Functionality for Large and Small HVAC Systems.” National Conference on Building Commissioning.

Fernandez et al. 2009. "Self-Correcting HVAC Controls Project Final Report." Pacific Northwest National Laboratory. Prepared for the U.S. Department of Energy. PNNL-19074.

Jacobs, Pete. 2003. "Small HVAC Problems and Potential Savings Reports." Prepared for California Energy Commission. P500-03-082-A-25.

Miyata et al. 2005. "Estimation of Excessive HVAC Energy Consumption due to Faulty VAV Units." Ninth International IBPSA Conference. p 777-784.

Roth et al. 2005. "Energy Impact of Commercial Building Controls and Performance Diagnostics: Market Characterization, Energy Impact of Building Faults and Energy Savings Potential." TIAX LLC. Prepared for U.S. Department of Energy.

B.7 Dedicated Outdoor Air System

Systems Impacted by Technology		Energy-Savings Performance	Technical Maturity
Ducted HVAC Systems		0.44 Quads/yr	Comm. Available
Peak-Demand Reduction Potential	Non-Energy Benefits	Ease of Retrofit	Cost/Complexity
Low	Increased Ventilation	Medium	Medium

Description of Technology

In a typical ducted HVAC system, return air mixes with outdoor ventilation air before redistribution to the conditioned space. Current building standards require high amounts of fresh outdoor air (OA) to maintain acceptable indoor air quality (IAQ). When OA conditions differ from return air, conditioning the mixed air consumes significant energy. A dedicated outdoor air system (DOAS) separates the ventilation air from the primary recirculating air system. DOAS delivers the correct amount of ventilation without compromising thermal comfort and allows the entire HVAC system to operate more efficiently.

Description of How Technology Saves Energy

A parallel DOAS provides energy savings by independently meeting the separate space conditioning and ventilation loads. Providing the precise volume of OA needed reduces fan usage and the cost to condition the OA. The DOAS can act as an economizer when OA conditions permit and use a desiccant wheel for dehumidification. Bringing the OA down to cool dry conditions allows for latent space cooling from the DOAS. When DOAS controls the latent heat load, the primary recirculation system can provide sensible heating/cooling with better COP.

Potential for Retrofit

This strategy can be employed on existing buildings where the additional ductwork can be accommodated.

Potential Scope of Impact

Buildings with ducted HVAC systems are candidates for DOAS. The building should be sealed against OA infiltration to reduce humidity contamination. Based on an analysis of its potential impact on HVAC systems in the U.S., this technology would save 0.132 Quads of natural gas, and 0.304 Quads of electricity per year.

Energy-Savings Performance

TIAX (2006) experimented with an integrated DOAS unit and found a 10% overall efficiency improvement. In certain climates, the savings were estimated over 17%.

McDowell and Emmerich (2005) examined the use of DOAS in various U.S. climates. They found savings of 14-37%, especially in moderate Northern climates.

Fischer and Bayer (2003) investigated DOAS as a solution to poor ventilation in schools. Besides providing higher IAQ, they found a 22% energy savings after installation.

E Source (2009) found that using DOAS decreased OA volume by 20% resulting in a COP increase of 20% for the primary compressor driven system. Total energy savings are 8-12% on heating and 15-20% on cooling.

Cost Information

TIAX (2006) estimated a 10-20% increase in manufacturing costs for an integrated DOAS system compared to an 11-EER conventional system.

Dieckmann et al. (2007) believed that a DOAS would have a payback of 1-4 years in new construction and major renovation projects. Primary equipment can be downsized with the use of a parallel DOAS.

Peak-Demand Reduction and other Benefits beyond Energy-Efficiency Gains

IAQ is maintained with the precise use of ventilation air. DOAS operates most efficiently in part-load conditions and will not result in large peak reductions.

Technical Maturity and Recent Developments

This is a commercial available technology.

Barriers to Market Adoption

Most barriers to DOAS deal with public perception and designer unfamiliarity. Many believe that having two systems is inefficient, but when designed and sized correctly, first cost can be minimal or lower than a single conventional system. Infiltration of OA through the building envelope decreases performance. DOAS requires the use of sensors and controls connected throughout the HVAC system.

Opportunities and Next Steps for Technology

Buildings in moderate climates that require significant ventilation will benefit most from DOAS. Manufacturers offer DOAS integrated into packaged equipment, reducing their size while allowing for parallel airflow distribution. Much work has been done to show the benefits of increased ventilation for productivity and IAQ, but few models are available to predict DOAS performance.

References

Dieckmann et al. 2007. "Dedicated Outdoor Air Systems Revisited." ASHRAE Journal. December 2007. p 127-129.

E Source. 2009. "HVAC: Dedicated Outdoor Air Systems." Wisconsin Public Service. Retrieved from <http://www.wisconsinpublicservice.com/>.

Emmerich and McDowell. 2005. "Initial Evaluation of Displacement Ventilation and Dedicated Outdoor Air Systems in Commercial Buildings." National Institute of Standards and Technology. NISTIR 7244.

Fischer and Bayer. 2003. "Failing Grade for Many Schools - Report Card on Humidity Control." ASHRAE Journal. May 2003. p 30-37.

TIAX LLC. 2006. "Rooftop Unitary Air Conditioner with Integral Dedicated Outdoor Air System." National Renewable Energy Laboratory. U.S. Department of Energy. Agreement Number DE-FC26-03NT41949.

B.8 Dual-Source Heat Pump

Systems Impacted by Technology		Energy-Savings Performance	Technical Maturity
Packaged Cooling and Heat Pump Equipment		0.02 Quads/yr	Emerging
Peak-Demand Reduction Potential	Non-Energy Benefits	Ease of Retrofit	Cost/Complexity
Low	None	Low	Medium

Description of Technology

The dual-source heat pump is a hybrid heat pump system that uses both air and geothermal sources for the condensing process in the cooling mode and the evaporating process in the heating mode. The economy of dual-source technology is more favorable compared to a traditional ground-source heat pump, as the ground loop requirements are significantly smaller, reducing the initial cost of the system.

Description of How Technology Saves Energy

On the cooling mode, the liquid refrigerant discharging from an air-source condenser is sub-cooled by a fluid cooled by a ground-source condenser. After the sub-cooler, this fluid is then reused to remove some of the superheat from the hot gas before it goes into the air-source condenser. This process can increase net cooling capacities by more than 1% per degree of sub-cooling. Factors that affect the technology performance include refrigerant types, evaporator temperature, and evaporator surface area.

Desuperheating with a secondary fluid, or by direct geothermal contact, results in much more rapid desuperheating of the hot gas refrigerant than does air-source desuperheating. This rapid desuperheating results in much lower back head pressure to the compressor, and therefore results in significantly reduced power consumption, a cooler-running compressor, and higher refrigerant mass flow.

Potential for Retrofit

The potential for retrofit installation is low, given the invasiveness of ground loop installation.

Potential Scope of Impact

Dual-source heat pumps work well in applications which require sizable space/water heating and cooling for extended periods of time. Buildings that do not meet the surface area requirements of traditional ground-loop heat pumps would be candidates for dual-source systems. Based on an analysis of its potential impact to HVAC systems in the U.S., this technology would save 0.0 Quads of natural gas, and .019 Quads of electricity per year.

Energy-Savings Performance

According to FEMP (2000), Global Energy & Environmental Research, Inc. (GEER) reports dual-source heat pump performance of 18 to 21 EER for cooling, and COPs of about 3.5-4 for heating, under typical ARI conditions for laboratory testing.

Data collected through a field demonstration at a military training facility by GEER suggests that dual-source heat pump reduced the heating season energy use from 4,000 kWh vs. 3,400 kWh, or 15% reduction, when compared to an air-source alternative. The reduction in energy use in the cooling season is even greater, from 10,300 kWh to 7,100 kWh, or 31% reduction.

During another field demonstration at a public service facility, daily energy use was reduced by nearly 38% from 319 kWh before the demonstration to 199 kWh. On a typical cooling day, peak demand was reduced by almost 8 kW, from the previous peak demand of 18.3 kW.

Cost Information

The ground loop installation makes the initial costs higher for dual-source system compared to air-source heat pumps. However, the initial costs would still be lower for dual-source system than group-source heat pump given the relatively smaller ground loop requirement. FEMP (2000) suggests that on a life-cycle cost basis, a dual-source heat pump “should frequently be the most cost-effective alternative, but not in every circumstance.”

Peak-Demand Reduction and other Benefits beyond Energy-Efficiency Gains

Compared to a solely air-source heat pump, there will be a peak-demand reduction associated with the dual-source system, but will vary.

Technical Maturity and Recent Developments

This is an emerging technology with limited availability in the US market today. This technology is available only from GEER, which manufactures a line of residential units and retrofit packages for larger commercial-sized systems. Residential sizes range from 2.5-ton to 5-ton nominal cooling capacities with a 20+ SEER under rated conditions. GEER also makes the dual-source technology available as a retrofit package for commercial HVAC systems in the 5- to 30-ton range. In the retrofit application, the existing compressor(s) are replaced with downsized high-efficiency compressor(s) and the dual-source geothermal technology. The compressors can be downsized because the dual-source technology makes up the difference in capacity.

Barriers to Market Adoption

Installation costs, while lower than those of ground-source heat pump, may be too high for many of the potential customers. There is limited applicability to retrofit market, given the need for invasive ground loop installation.

Opportunities and Next Steps for Technology

Buildings which would be candidates for traditional ground-source heat pumps would benefit from dual-source heat pumps as well. This market could be expanded to include projects that cannot accommodate the larger area requirements of traditional ground-source systems, and provide lower installation costs.

References

Federal Energy Management Program (FEMP), 2000 “Energy Savings from Dual-Source Heat Pump Technology.” Technology Installation Review. DOE/EE-0220.

B.9 Duct Static Pressure Reset Control

Systems Impacted by Technology		Energy-Savings Performance	Technical Maturity
VAV Systems		0.09 Quads/yr	Comm. Available
Peak-Demand Reduction Potential	Non-Energy Benefits	Ease of Retrofit	Cost/Complexity
Low	Less noise/maintenance	High	Medium

Description of Technology

For large commercial buildings, VAV systems provide efficient zonal control over a large area. Typically, the individual VAV terminal units control comfort by maintaining constant static pressure and the fan flow rate in the main duct. Fan power consumption can decrease by reducing duct static pressure to the minimum setting where VAV boxes still supply the necessary load. By resetting pressure control, the fan can slow down, and the VAV dampers open until one terminal box sends a critical signal. At this point, the damper of the critical box is nearly completely open and the fan stabilizes the supply duct pressure at this level. Static pressure reset (SPR) systems consist of a network of damper position sensors connected to a central controller that can modulate the fan speed. Building automation or energy management systems (BAS/EMS) implement SPR control to reduce both the fan and thermal energy required in a VAV system.

Description of How Technology Saves Energy

SPR control reduces the fan requirement of a VAV system while providing sufficient comfort and airflow to the building occupants. By opening the dampers, a greater percentage of supply air reaches the zone, so the fan speed can decrease to meet the load. Besides reducing the fan power consumption, the system conserves thermal energy by reducing the volume of air needing conditioning.

Potential for Retrofit

VAV systems have either pneumatic or direct digital control (DDC) between the terminal boxes, supply fan, and heating/cooling equipment. SPR strategies can be implemented for any control type as long as the fan speed can change. This strategy can be applied on existing control systems or new BAS/EMS.

Potential Scope of Impact

Buildings that use VAV systems for HVAC can benefit from SPR control. Based on an analysis of its potential impact on HVAC systems in the U.S., this technology would save 0.09Quads of electricity per year.

Energy-Savings Performance

Taylor (2007) discussed various SPR control strategies to reduce energy use in VAV systems. He noted that SPR could reduce fan energy use by 30-50% in properly designed systems.

Scruton et al. (2008) found that buildings could reduce fan energy by 30% without any change in comfort or indoor air quality.

Liu et al. (2011) built a simulation model to determine the fan and thermal energy savings for a building using SPR. Baseline fan savings were found to be 15% and would increase with the presence of duct leakage.

Wray and Sherman (2010) implemented a SPR control system into a large commercial office building and found a 25-30% reduction in fan energy use.

Cost Information

Scruton et al. (2008) found that the payback for installing SPR control for two buildings in California was less than a year.

The additional cost of implementing SPR into new BAS/EMS can be minimal.

Peak-Demand Reduction and other Benefits beyond Energy-Efficiency Gains

SPR reduces fan usage particularly during partial-load hours. Reduced fan speed and duct airflow decrease system noise and damper malfunction.

Technical Maturity and Recent Developments

This is a commercial available technology.

Barriers to Market Adoption

Not all VAV systems will benefit from SPR without modifications to existing practices. Undersized VAV boxes, zone thermostats which operate lower than design temperatures, and other considerations can be solved through custom control logic. Many existing buildings do not have DDC controls or damper position sensors, and would require a VFD drive for the supply fans. SPR often requires trial-and-error tuning during the installation and commissioning process.

Opportunities and Next Steps for Technology

SPR control reduces the significant fan usage for VAV systems in commercial buildings. As more buildings go to advanced BAS/EMS, these control strategies will become commonplace. More work needs to be done to understand the thermal energy effects of SPR since case studies have shown both increases and decreases in thermal energy use. Older systems would additionally benefit from the upgraded damper position sensors since their commissioning would find any malfunctions which would also decrease efficiency.

References

Liu et al. 2011. "Impacts of Static Pressure Reset on VAV System Air Leakage, Fan Power and Thermal Energy – Part I: Theoretical Model and Simulation." University of Nebraska, Lincoln.

Scruton et al. 2008. "Static Pressure Reset Strategy Boosts VAV System Efficiency." California Energy Commission's Public Interest Energy Research (PIER) Program. CEC-500-2008-046-FS.

Taylor, Steven. 2007. "Increasing Efficiency with VAV System Static Pressure Setpoint Reset." ASHRAE Journal. June 2007. p 24-32.

Wray and Sherman. 2010. "Duct Leakage Modeling in EnergyPlus and Analysis of Energy Savings from Implementing SAV with InCITe." Lawrence Berkley National Laboratory.

Wray et al. 2008. "Heating, Ventilating, and Air-Conditioning: Recent Advances in Diagnostics and Controls to Improve Air-Handling System Performance." Lawrence Berkley National Laboratory.

B.10 Electrohydrodynamic Heat-Transfer Enhancement

Systems Impacted by Technology		Energy-Savings Performance	Technical Maturity
Vapor Compression Heat Exchangers		0.02 Quads/yr	R&D(short-term)
Peak-Demand Reduction Potential	Non-Energy Benefits	Ease of Retrofit	Cost/Complexity
Low	Controllability, Less Refrigerant	High	High

Description of Technology

Active heat transfer enhancement requires energy input into the system to raise effectiveness of an HVAC heat exchanger (HX). Electrohydrodynamic (EHD) enhancement systems increase heat transfer rate with minimal additional power requirements. An EHD system uses high-voltage (>1kV), low-current, electricity from integrated electrodes to create an electric field and incite fluid mixing. Incorporating EHD electrodes in a HX decreases the size of a conventional HX but provides higher operating efficiencies and controllability.

Description of How Technology Saves Energy

EHD systems enhance heat transfer by causing greater fluid mixing especially in two-phase refrigerant flows. The electrodes placed in the evaporator incite quicker boiling of the refrigerant as it flows over the electric field. For condensers, the refrigerant gas increases vorticity in the presence of the electric field and rejects a larger amount of heat. The imbedded electrodes do consume electricity and cause an increase in fluid pressure drop, but the heat transfer benefits outweigh additional power consumption.

Potential for Retrofit

This technology will be a component in high-efficiency replacement equipment.

Potential Scope of Impact

Vapor compression systems will use EHD electrodes in evaporators and condensers. Based on an analysis of its potential impact to HVAC systems in the U.S., this technology would save 0.02 Quads of electricity per year.

Energy-Savings Performance

Dulikravich et al. (1993) developed a mathematical model to analyze fluid flows with EHD systems. They found a 12-64% increase in heat transfer efficiency from their models.

Baumgarten (2003) investigated the performance of EHD electrodes in a metal heat exchanger. He found a 3 fold increase in heat transfer capacity with a 2.4 fold increase in pressure drop.

Kasayapanand and Kiatsiriroat (2007) performed CFD analyses on heat exchangers with a variety of EHD systems. They noted an overall 25% increase in heat transfer and found that an intermediate number of electrodes optimizes system efficiency.

Laohalertdecha et al. (2007) reviewed the current published research on EHD technology and found that a 27-100% efficiency increase can be expected for use with two-phase fluids. They summarized the effect of EHDs by a ratio of heat transfer coefficients with and without the enhancements in systems with modern refrigerants. Generally, use with condensers had a ratio of 1-7 while evaporators had a ratio of 1-6.

Cost Information

Little quantitative cost data is available for EHD systems. Heat exchangers with EHDs will use less material but can be more difficult to manufacture and involve the electronics.

Peak-Demand Reduction and other Benefits beyond Energy-Efficiency Gains

Capacity can be regulated by controlling the voltage applied by the EHD electrode. This can lead to improved part-load efficiency and performance.

Technical Maturity and Recent Developments

This technology is not commercially available, with a few product development issues to be resolved through short-term R&D activities. EHD systems are currently used in other industries for cooling small electronics. Extensive research had been done at the academic level but no commercial product development has taken place.

Barriers to Market Adoption

Reliability of EHD electrodes and how they react with refrigerants over time is not well known at this point. Using high voltage in HVAC equipment poses a safety risk. Limited testing has occurred in real world HVAC systems. Costs are an unknown for HVAC applications.

Opportunities and Next Steps for Technology

EHD systems can be optimized to raise heat transfer output while minimizing the power consumption and fluid pressure drop. The orientation, number, and type of electrodes used in an EHD system determine its effectiveness. Field testing of HVAC systems utilizing EHD electrodes should determine its reliability for future use. Cost parameters still need to be determined for heat exchangers with EHDs.

References

Baumgarten, Bruce. 2003. "EHD-Enhanced Heat Transfer in a Metallic and Ceramic, Compact Heat Exchanger." University of Maryland.

Dulikravich et al. 1993. "Simulation of Electrohydrodynamic Enhancement of Laminar Flow Heat Transfer." *Enhanced Heat Transfer*. 1993 Vol. 1, No. 1. p 115-126.

Kasayapanand and Kiatsiriroat. 2007. "Numerical Modeling of the Electrohydrodynamic Effect to Natural Convection in Vertical Channels." *International Communications in Heat and Mass Transfer*. Vol. 34, Issue 2, February 2007. p 162-175.

Laohalertdecha et al. 2007. "A Review of Electrohydrodynamic Enhancement of Heat Transfer." *Renewable and Sustainable Energy Review*. Vol. 11, Issue 5, June 2007. p 858-876.

B.11 Fans Optimized for Every Application

Systems Impacted by Technology		Energy-Savings Performance	Technical Maturity
Fans (especially axial)		0.09 Quads/yr	Comm. Available
Peak-Demand Reduction Potential	Non-Energy Benefits	Ease of Retrofit	Cost/Complexity
Low	Noise Reduction	High	Low

Description of Technology

Fan manufacturers offer many configurations to match size, airflow, and rotational speeds to meet the needs of an HVAC system. Each motor speed has an optimum geometry maximizing the airflow to motor power ratio. HVAC fans typically have mass-produced stamped aluminum blades to cover a greater number of systems with only a few models. In many instances, fan and system efficiency can be improved through custom manufacturing of fans for each specific application.

Description of How Technology Saves Energy

Off-the-shelf mass produced fans are designed to provide adequate efficiency and airflow over many different fan speeds. Each HVAC application has a specific airflow requirement, and for a given motor, there are optimal blade geometries. A custom fan made to fit these specific conditions performs with greater efficiencies than conventional fans. The blade profile, pitch, and blade count constructed from polymer molding provides long, reliable service life at the optimum design conditions.

Potential for Retrofit

Custom molded fans can be retrofit or a component in high-efficiency replacement equipment.

Potential Scope of Impact

Most HVAC systems could benefit from use of fans built through mass-customization methods. Axial fans can most benefit from aerodynamically improved blade geometries. Based on an analysis of its potential impact on HVAC systems in the U.S., this technology would save 0.9 Quads of electricity per year.

Energy-Savings Performance

Monroe (1979) discussed the benefits of using custom fiberglass fans to optimize performance, reduce noise and minimize energy use. For a certain fan speed, there is a pitch angle of peak efficiency and 10-15% drop in performance outside of this design condition.

Dubin and Homs (2003) compared a 5-blade injection molded fan vs. a 3-blade conventional stamped fan. The customized molded fan had a 14-30% better airflow to power ratio over a range of fan speeds.

Parker et al. (2005) experimented on a condenser fan with airfoil shaped blades. This resulted in a 21% fan efficiency and a 6-8% total system improvement.

Cost Information

Custom fans will cost more than conventional stamped fans upfront. The design flexibility, energy savings, noise reduction, and potential smaller motor sizing make optimized fans commercially advantageous, especially for packaged systems.

Peak-Demand Reduction and other Benefits beyond Energy-Efficiency Gains

Custom molded fans operate with less noise.

Technical Maturity and Recent Developments

This is a commercial available technology. Computer aided design and analysis software as well as mature molding technologies have made mass-customization of HVAC fans possible.

Barriers to Market Adoption

Higher first cost and added design steps are roadblocks to full utilization of this technology.

Opportunities and Next Steps for Technology

Packaged HVAC systems featuring factory customized options should include advanced molded fans in the user designed process. Additional field research should demonstrate the benefits of optimized fan design in HVAC systems.

References

Dubin and Homsy. 2003. "Comparing the Performance of Plastic and Metal HVAC Fans." BASF Corporation.

Monroe, Robert. 1978. "Improving Cooling Tower Fan System Efficiencies." Hudson Products Corporation. Combustion Magazine. Vol. 50, No. 11. May 1979.

Multi-Wing. Retrieved from <http://www.multi-wing.net>.

Parker et al. 2005. "Development of High Efficiency Air Conditioning Condenser Fans." ASHRAE Transactions. June 2005.

Swifter. 2011. "Frequently Asked Questions for Industrial Fans." Retrieved from <http://www.swifterfans.com>.

B.12 High-temperature Superconducting Motors

Systems Impacted by Technology		Energy-Savings Performance	Technical Maturity
Fan/Pump/Compressor Motors >1000 HP		0.06 Quads/yr	R&D (short-term)
Peak-Demand Reduction Potential	Non-Energy Benefits	Ease of Retrofit	Cost/Complexity
Low	Compact Size	High	High

Description of Technology

High-temperature superconducting motors (HTSM) use superconducting wires as field windings in the synchronous rotor of the electromechanical machine. The superconducting wires carry larger amounts of current per volume than normal copper windings, providing higher power density for the motor. First generation superconducting materials required operating temperatures around 10 °K while second generation high-temperature materials operate in the 60-80 °K range. Cryogenic refrigeration equipment connected with the motor provides the required low temperatures. By having higher power density, the HTSMs can be smaller, lighter, and more efficient than other industrial motors.

Description of How Technology Saves Energy

HTSMs operate with higher efficiencies since the superconducting rotor windings operate with little or no resistive losses. The normal I^2R losses associated with current carrying copper wires are eliminated when the superconducting wires run below their critical temperature. Without heat losses, the increased motor efficiency and power density allows the motor to be made smaller while maintaining output capacity.

Potential for Retrofit

A HTSM can be retrofit to existing large HVAC systems because high-output motors are typically placed in an area where they can be serviced regularly. The smaller size of HTSMs and the additional refrigeration equipment will need to be accounted for in a retrofit situation.

Potential Scope of Impact

Although there have been HTSMs built down to less than 10hp, only large motors (>1000hp) will be economically feasible in the near future. For HVAC systems, this will mean large centrifugal chillers, fans and pumps in continuous operation. Based on an analysis of its potential impact on HVAC systems in the U.S., this technology would save 0.06 Quads of electricity per year.

Energy-Savings Performance

Schiferl and Rey (2006) presented on recent industry findings and noted that HTSMs have 50% less losses than other motor types. This number is reflected throughout many industry sources.

American Superconductor (2011) touts its Amperium, second generation, superconducting wire for having a 100 fold improvement over a copper wire of the same size.

SuperPower Inc. (2011) has provided HTSMs for naval applications with 98% efficiency.

Cost Information

Schiferl and Rey (2006) discussed how HTSMs will be cost effective in motors >1000hp due to their higher efficiency, lower life cycle costs, compact design, and longer lifespan. The additional first cost of smaller HTSMs currently does not make it practical. This opinion is held throughout the industry and commercial product development is in >1000hp range.

Peak-Demand Reduction and other Benefits beyond Energy-Efficiency Gains

Other benefits include a more compact motor system.

Technical Maturity and Recent Developments

This technology is not commercially available, with a few product development issues to be resolved through short-term R&D activities. Superconducting wires are being used in many applications including electric power transmission cables and transformers. HTSMs are being funded and developed for ship propulsion in the U.S. Navy. Companies such as American Superconductor, SuperPower Inc., and Reliance Electric are working with Oak Ridge National Laboratory and various Navy research labs to bring HTSMs into wider use.

Barriers to Market Adoption

High first cost and low market familiarization will be tough to overcome for uses in HVAC.

Opportunities and Next Steps for Technology

HTSMs are cost effective and energy-efficient motors in high horsepower applications. Centrifugal chiller manufacturers should use the current technology in product development of compressor motors.

References

American Superconductor. 2011. Retrieved from <http://www.amsc.com>.

Driscoll et al. 2000. "Development Status of Superconducting Motors." IEEE Power Engineering Review 2009. p 12-15.

Rockwell Automation. 2005. "Genius Strikes Again." A-B Journal. November, 2005.

Schiferl and Rey. 2006. "Development of Ultra Efficient HTS Electric Motor Systems." 2006 Annual Superconductivity Peer Review Meeting. Washington, DC. July 26, 2006.

SuperPower Inc. 2011. Retrieved from <http://www.superpower-inc.com>.

B.13 Hot-Dry Air-Conditioner

Systems Impacted by Technology		Energy-Savings Performance	Technical Maturity
Direct A/C systems in hot and dry climates		0.14 Quads/yr	Emerging
Peak-Demand Reduction Potential	Non-Energy Benefits	Ease of Retrofit	Cost/Complexity
High	None	Medium	Low

Description of Technology

Hot-dry air-conditioners operate using the same vapor-compressor system as conventional air-conditioning systems. However, conventional systems are rated using humid test conditions, and so their performance is optimized for performance in humid climates. Hot-dry air-conditioners are designed to optimize performance in hot-dry climates, by tweaking standard air-conditioner components found in conventional air conditioners (Buntine et al., 2007). Adjustments may include:

- Higher saturation temperature evaporator coil;
- Higher airflow across the evaporator coil;
- Controls to minimize latent capacity under dry indoor conditions;
- Increased condensate retention on the evaporator coil;
- Controls to obtain latent capacity when indoor moisture rises significantly; and
- Controls to evaporate moisture off the coil rather than allow condensate drainage;

Description of How Technology Saves Energy

Currently, the minimum efficiency standards for air-conditioners are roughly based on an artificially calculated “average” cooling season weather conditions across the United States. Because of this, commercially available air-conditioners today are not designed to perform optimally in hot and dry conditions that are prevalent in southwestern states, including California, Arizona, New Mexico, Colorado, Utah, Nevada and parts of western Texas. (Buntine et al., 2007) Field testing of prototypical units indicated that they can reduce energy consumption by 17% to 29% (Proctor, 2007).

Potential for Retrofit

Any HVAC system installed in hot/dry climate, including California, Mountain states and parts of Texas would benefit from this technology option.

Potential Scope of Impact

New and existing buildings with direct air-conditioning systems in hot and dry climates. Based on an analysis of its potential impact to HVAC systems in the U.S., this technology would save .14 Quads of electricity per year.

Energy-Savings Performance

According to Buntine, et al (2007), the results from laboratory and field testing demonstrated energy savings of up to 20 percent.

Cost Information

Buntine, et al. (2007) estimates the incremental cost of HDAC at \$246 for the Residential Unit and \$67 for the Commercial unit in California. These estimated were derived using the DOE methodology as used in federal rule setting. The results are similar to a previous study produced by LBNL for the CEC (Rosenfeld et al., 2005).

Peak-Demand Reduction and other Benefits beyond Energy-Efficiency Gains

According to Buntine, et al. (2007), the results from laboratory and field testing demonstrated peak-demand reductions of up to 35%. Regions with hot/dry climate are summer peaking utility regions, and air conditioning is the primary cause of the peaks. In California, residential air conditioning has a ratio of peak load to average load of 3.5 to 1.

Technical Maturity and Recent Developments

This is an emerging technology with limited availability in the US market today. Manufacturers developed several prototypes as part of the PIER project, and these were laboratory tested and field tested [Buntine, et al., (2007)].

Barriers to Market Adoption

The market would be able to adopt HDAC once it is commercially developed. However, the energy cost savings must be sufficiently large to justify the incremental cost of HDAC, which is not yet demonstrated outside of California. While Buntine, et al. (2007) suggests that the industry stakeholders engaged during the study “indicated confidence and a willingness to sell and install HDAC units” in California, similar level of enthusiasm would be required in other applicable states to be able to capture the entire market.

Opportunities and Next Steps for Technology

This technology is intended for application in southwestern United States. While the performance potential of HDAC is well documented for applications in California, additional demonstrations may be needed in other hot/dry areas with more extreme weather conditions (e.g., Arizona and New Mexico).

References

Buntine, Chris, Southern California Edison; Proctor, John, Proctor Engineering, Ltd.; Knight, Robert, Bevilacqua-Knight, Inc.; Cherniack, Mark, New Buildings Institute, 2007. “Energy Performance of Hot Dry Air Conditioning Systems.” California Energy Commission, PIER Building End-Use Energy Efficiency Program. CEC-500-2008-056.

Proctor Engineering Group, Ltd. “Hot Dry Climate Air Conditioner (HDAC) Combined Field Test Report.” Prepared for: Southern California Edison Company. Final Report, July 19, 2007.

Rosenfeld, Arthur, et al. "Economic Evaluation of Residential Air Conditioner Designs for Hot Dry Climates." Presentation at ARI Spring Product Section Meeting. April 18, 2005. California Energy Commission.

B.14 Membrane Humidity Control with Advanced Active Desiccant Materials

Systems Impacted by Technology		Energy Savings Performance	Technical Maturity
Packaged HVAC Systems		0.14 quads/yr	Emerging
Peak Demand Reduction Potential	Non-Energy Benefits	Ease of Retrofit	Cost/Complexity
Medium	Improved IAQ	Medium	Medium

Description of Technology

The Active Desiccant Module (ADM) combines a rooftop unitary air conditioner with an active desiccant wheel to dry a portion of the air that is treated by the system’s evaporator. By placing the desiccant behind the evaporator, the desiccant’s performance is enhanced by providing saturated air. The dried air is then mixed with the rest of the air going through the evaporator (Sand 2003). The system is intended as a replacement for current packaged rooftop units.

The system uses less heat to regenerate the desiccant (compared to typical desiccant applications), and can be combined with water heating or CHP applications for further energy savings (Sand 2003).

Description of How Technology Saves Energy

Conventional packaged rooftop systems are oversized to handle both ventilation and cooling loads. To provide appropriate humidity levels, these systems overcool incoming air before reheating it to the supply temperature. By eliminating excessive overcooling and reheating, the ADM system allows for decreased unit sizing (Sand 2005). Placed behind the evaporator, the ADM also minimizes compressor cycling and enhances the effectiveness of the desiccant material (Sand 2003).

Potential for Retrofit

The ADM system was specifically designed to act as a direct replacement for conventional packaged rooftop units.

Potential Scope of Impact

Based on an analysis of its potential impact to HVAC systems in the U.S., this technology would save .000 Quads of natural gas, and .140 Quads of electricity per year.

Energy Savings Performance

Sand (2005) noted that the EER of the ADM system (13.6 EER) was 20% higher than that of a typical rooftop unit. By varying the compressor speed, the unit achieved further EER gains (up to 20 EER).

Cost Information

Sand (2005) noted that the ADM approach is extremely cost competitive with current technologies. The estimated installation costs (per sq.ft.) for the ADM are 15-35% lower than conventional packaged systems, both with and without recovery and DOAS systems. Based on

test data, Sand (2003) also noted that operating costs for the ADM system could be 45% less than conventional systems that over-cooled and then reheated incoming air.

Peak Demand Reduction and other Benefits beyond Energy Efficiency Gains

A system that removes outdoor air humidity offers opportunities for improved indoor air quality and improved comfort.

Technical Maturity and Recent Developments

This is an emerging technology with limited availability in the US market today. SEMCO and ORNL jointly developed prototype products, and the product is available on the market. They developed prototypes for both DOAS and complete VAV systems. (Sand 2005)

Barriers to Market Adoption

Although the product will be limited to markets with moderate-to-high humidity, few barriers to market adoption remain. Principally, building owners and operators lack awareness of the benefits that ADM systems would provide.

Opportunities and Next Steps for Technology

Demonstrations to illustrate the long-term performance of ADM systems would raise industry awareness of the energy savings and benefits of this system.

References

Sand, James and Fischer, John. "Active Dessicant Integration with Packaged Rooftop HVAC Equipment." Oak Ridge National Lab. IRC0415. International Congress of Refrigeration 2003, Washington DC.

Sand, James and Fischer, John. "Field Test and Performance Verification: Integrated Active Dessicant Rooftop Hybrid System Installed in a School." Final Report: Phase 4a. November 2005. ORNL/Sub-01-4000025209.

B.15 Microchannel Heat Exchangers

Systems Impacted by Technology		Energy-Savings Performance	Technical Maturity
Vapor Compression Heat Exchangers		0.20 Quads/yr	Comm. Available
Peak-Demand Reduction Potential	Non-Energy Benefits	Ease of Retrofit	Cost/Complexity
Low	Lower Refrigerant Charge	High	Medium

Description of Technology

Microchannel heat exchangers (MCHX) use many thin (<2mm) tubes connected in parallel to facilitate heat transfer between air and refrigerant. The summation of numerous tiny channels results in less volume, face area, and weight while maintaining high capacity. The depth of the microchannels is limited in order to maintain a moderate fan pressure drop. Originally found in automobile air-conditioning systems, the MCHX provides efficient heat transfer performance in tightly packaged situations. Their use in commercial HVAC equipment has risen to meet demand for high efficiency, compact, and environmentally conscious air-conditioners.

Description of How Technology Saves Energy

MCHXs greatly increase the surface area to volume ratio over conventional shell-and-tube or finned-tube heat exchangers. The thin microchannels provide a large heat transfer surface with a small area requirement, reducing airflow restriction and fan usage. The low-volume microchannels provide comparable capacity with less refrigerant, lowering compressor energy consumption.

Potential for Retrofit

This technology will be a component in high-efficiency replacement equipment.

Potential Scope of Impact

Evaporators and condensers for vapor compression systems. Based on an analysis of its potential impact on HVAC systems in the U.S., this technology would save 0.20 Quads of electricity per year.

Energy-Savings Performance

Danfoss (2009) developed a MCHX which uses the increased efficiency to reduce refrigerant charge by 40-50%.

Turpin (2008) reported that MCHX use reduces fan use by 20% compared to other heat exchangers in industry.

Westphalen et al. (2003) estimated the total system energy savings of a unitary air conditioner with a MCHX to be 10%.

Cost Information

MBI (2011) found that MCHXs provide the same capacity with a 5-10 fold reduction in volume and 2-5 fold reduction in weight.

Turpin (2008) reported decreases in face area and weight of 40% and 30% respectively.

Westphalen et al. (2003) estimated that the efficiency gains of MCHX result in a one to two-thirds cost reduction compared to a conventional heat exchanger.

Peak-Demand Reduction and other Benefits beyond Energy-Efficiency Gains

Systems with MCHX require less refrigerant.

Technical Maturity and Recent Developments

This is a commercial available technology. Many large HVAC manufacturers are incorporating MCHXs into their product offerings including McQuay, Carrier, Trane, and York, among others.

Barriers to Market Adoption

Switching manufacturing processes over to MCHX technology was the primary hurdle before larger implementation. Recent developments in manufacturing technology have made MCHX mass-production easier.

Opportunities and Next Steps for Technology

Equipment manufacturers include MCHXs in their current high-efficiency and environmentally conscious products. Improvements in the manufacturing of MCHXs should increase its applicability to more commercial systems.

References

Danfoss. 2009. "Microchannel Heat Exchanger Technology—Best Practices from Auto Industry Lead to Increased Efficiency in Air Conditioning." Danfoss United Kingdom.

Kulkarni and Bullard. 2003. "Design Tradeoffs in Microchannel Heat Exchangers." University of Illinois. Air Conditioning and Refrigeration Center. ACRC TR-208.

MBI. 2011. "Advanced Microchannel Heat Exchangers." Microproducts Breakthrough Institute. Retrieved from <http://mbi-online.org>.

Tonkovich, Anna Lee. "Microchannel Heat Exchangers: Applications and Limitations." Velocys, Inc. Presentation from <http://www.velocys.com>

Turpin, Joanna. 2008. "Microchannel Coil Moves into Commercial Apps." Air Conditioning, Heating & Refrigeration News. May 19th, 2008.

Westphalen et al. 2003. "Microchannel Heat Exchangers." ASHRAE Journal, December 2003. p 107-109.

B.16 Mixed-mode Conditioning

Systems Impacted by Technology		Energy-Savings Performance	Technical Maturity
Cooling and Ventilation Systems		0.04 Quads/yr	Comm. Available
Peak-Demand Reduction Potential	Non-Energy Benefits	Ease of Retrofit	Cost/Complexity
Low	IAQ/Comfort	Low	Medium

Description of Technology

Mechanically driven HVAC systems typically supplies both ventilation and cooling to maintain proper indoor comfort for commercial buildings. Outdoor air (OA) passively enters buildings through windows to provide ventilation and possibly cooling if designed appropriately. Mixed-mode conditioning (or hybrid ventilation) combines a mechanical cooling system with passive ventilation to reduce HVAC energy use where applicable. OA cycles through a building, rising from lower level windows to rooftop exits driven by thermal buoyancy or breezes. The windows and vents that allow OA into the space can be controlled manually or by automated controls. Passive and mechanical building systems can operate at the same time (concurrent), one at a time (changeover), or in different parts of the building (zoned).

Description of How Technology Saves Energy

Mixed-mode conditioning uses the natural movement of OA throughout a building to provide ventilation without the use of a fan. When available, the ventilation can also act as an economizer and provide “free cooling” for the space. Overall, fan usage decreases with mixed-mode conditioning as well as lowered mechanical cooling during certain off-peak periods.

Potential for Retrofit

Nearly all mixed-mode conditioning projects require significant upfront architectural design, limiting its use in retrofit applications.

Potential Scope of Impact

Mixed-mode design would lower the energy consumption of conventional cooling and ventilation systems. Mechanical air-conditioning still provides cooling during peak periods. Based on an analysis of its potential impact on HVAC systems in the U.S., this technology would save 0.013 Quads of natural gas, and 0.03 Quads of electricity per year.

Energy-Savings Performance

Brager (2006) discussed the advantages of mixed-mode conditioning to improve occupant comfort and reduce building energy use. Energy savings vary with each location but a 24.5% total savings was realized in a case study.

Hu et al. (2007) found that buildings with mixed-mode conditioning would save 5-50% on yearly energy usage. They also noted that buildings only conditioned with ventilation air were impractical.

Anseeuw et al. (2008) examined a Vancouver community center constructed to use mixed-mode conditioning. An overall first year energy savings of 10% was found compared to pre-construction design models.

Cost Information

It is well understood that mixed-mode conditioning requires redundant systems to handle the ventilation and cooling. Costs will vary with each project due to the building layout, occupancy activity, and climate. The necessary additional upfront design increases costs substantially. Systems with automated controls are more expensive than user operated ones.

NSF/IUCRC (2004) estimated the cost of implementing mixed-mode conditioning systems to be \$5/sq.ft. for new construction, and \$17/sq.ft. for retrofit.

Peak-Demand Reduction and other Benefits beyond Energy-Efficiency Gains

Limited peak-demand reduction is possible because the cooling load will exceed the ventilation cooling capacity during peak hours.

Technical Maturity and Recent Developments

This is a commercial available technology.

Barriers to Market Adoption

Mixed-mode conditioning is not well known by system designers and has limitations in humid climates. Each building requires significant design work often catered to their specific location. The openings in the building envelope for OA ventilation also allow outdoor noise, pollution, insects, and animals to enter the building. Having any openings to the building, especially at night is also a security risk. Building energy codes often do not allow for windows to be present in a conditioned space.

Opportunities and Next Steps for Technology

Buildings in dry, moderate climates that require high-OA levels are best suited for mixed-mode conditioning. This is why most projects of this type take place on the West Coast of the U.S.

References

Anseeuw et al. 2008. "Integrated Design for Community Center." ASHRAE Journal. July, 2008. p 30-34.

Brager, Gail. 2006. "Mixed-Mode Cooling." ASHRAE Journal. Vol. 48, August 2006. p 30-37.

Grumman, David. 2003. "ASHRAE Green Tips." ASHRAE GreenGuide.

Hu et al. 2007. "Feasibility of Controlled Hybrid Ventilation in Mid Rise Apartments in the USA." Proceedings: Building Simulation 2007. p 478-485.

NSF/IUCRC. 2004. "Guidelines for High Performance Buildings 2004." Center for Building performance and Diagnostics at Carnegie Mellon University. Advanced Building Systems Integration Consortium.

B.17 Modular Chillers and Boilers

Systems Impacted by Technology		Energy-Savings Performance	Technical Maturity
Centralized Chillers and Boilers		0.03 Quads/yr	Comm. Available
Peak-Demand Reduction Potential	Non-Energy Benefits	Ease of Retrofit	Cost/Complexity
Low	Redundancy/Reliability	Medium	Medium

Description of Technology

Many commercial buildings receive hydronic heating and cooling from central boilers and chillers that often operate differently than designed. These systems operate most efficiently at their peak output since thermal pipe losses are minimized. Consequently in part-load conditions, large central chillers and boiler operate at lower-efficiency. Modular chillers and boilers consist of multiple smaller units which individually operate at high-efficiency and aggregate to meet the variable heating/cooling load. The peak and partial loads are met efficiently by controlling the output of any or all of the modular units.

Description of How Technology Saves Energy

Instead of having one or two heating/cooling units, many are used to meet the building load. Each of the modular units can be staged so that the smallest number of units operates at peak-efficiency. By having certain units fully on and others modulated or off, this strategy matches the building load without excess heating/cooling. Pipe losses do not vary much with output, minimizing their impact during peak conditions. Running a number of modular units at maximum output to meet a partial load reduces losses compared to large central systems.

Potential for Retrofit

Modular chillers and boilers are designed to be retrofit into existing buildings using freight elevators and standard doorways.

Potential Scope of Impact

Modular equipment replaces large centralized chillers and boilers for both energy-efficiency and redundancy improvements. Based on an analysis of its potential impact on HVAC systems in the U.S., this technology would save 0.02 Quads of natural gas, and 0.011 Quads of electricity per year.

Energy-Savings Performance

Energy savings with modular chillers and boilers depends on existing system efficiency, peak and partial operation load profile, and equipment maintenance schedules.

Colorado Springs Utilities (2005) modeled the impact of switching to modular boilers. They realized a 5-7.5% fuel savings.

Lawrence Berkley National Laboratory (2007) installed modular units to replace two central boilers and found significant savings. Fuel use decreased ~45% by switching to on-demand modular equipment to avoid idling, and an additional ~15% operational savings from the more efficient boiler design.

Cost Information

While modular chillers and boilers have more components during installation, the majority of these are smaller and relatively inexpensive pipes and valves. For retrofit, modular units are designed to be installed without any structural modifications to the building.

Peak-Demand Reduction and other Benefits beyond Energy-Efficiency Gains

Modular equipment offers better reliability, ease of redundancy, expansion capabilities, accessibility for maintenance, and lower sound output.

Technical Maturity and Recent Developments

This is a commercially available technology. More advanced modular units can provide simultaneous heating/cooling by using waste heat from the chiller to assist the boiler.

Barriers to Market Adoption

Customers often replace existing equipment rather than move to a modular design. First cost may be higher in certain situations. System energy-efficiency gains require extensive modeling but can be predicted.

Opportunities and Next Steps for Technology

Modular chillers and boilers have seen the greatest use in systems that require high-reliability, part-load operation, and redundancy. The smaller profile of the modular units also makes them attractive for retrofit situations where the building was constructed originally around the major HVAC equipment.

References

ClimaCool. 2006. ClimaCool Corp. Retrieved from <http://www.climacoolcorp.com/>.

Colorado Springs Utilities. 2005. "Modular Boilers to Save Energy." White Paper No. 13.

Lawrence Berkley National Laboratory. 2007. "Modular Boiler Systems for Laboratory Facilities." Laboratories for the 21st Century Technical Bulletin. December 19, 2007.

Multistack. 2011. Multistack LLC. Retrieved from <http://www.multistack.com/>.

B.18 Multilevel FDD (Fault Detection and Diagnostics)

Systems Impacted by Technology		Energy-Savings Performance	Technical Maturity
Essentially All Building HVAC Systems		0.44 Quads/yr	Emerging
Peak-Demand Reduction Potential	Non-Energy Benefits	Ease of Retrofit	Cost/Complexity
High	Longer Equipment Life	Medium	Medium

Description of Technology

Commercial buildings use multiple overlapping HVAC systems to provide space conditioning to occupants. These integrated multilevel systems build on each other so that if there is a malfunction to one component, many others will experience diminished performance. Fault detection and diagnostic (FDD) systems compare component operation to a baseline model and alert building operators of the need for maintenance. When applied to the hierarchical structure in multilevel HVAC systems, common problems that waste energy can be found at their source and remedied faster. For example, the FDD system may receive a fault from a number of VAV boxes unable to provide sufficient cooling to an area. Since a number of air-side terminal units show faults, the FDD software checks sensors on the chilled water distribution piping and finds that the chiller supply temperature is high. This multilevel approach directs service technicians to the source of the problem so they can be repaired quickly, saving time, energy, and money.

Description of How Technology Saves Energy

Multilevel FDD saves energy by integrating multiple HVAC systems so that when a failure or drop in efficiency occurs, the correct repairs are made quickly. Multilevel FDD does not fix problems directly, although this capability would exist if included as part of a wider building automation system (BAS). It is up to the maintenance personnel to follow the direction of the FDD system and repair equipment where needed. Multilevel FDD systems compare HVAC operations against robust whole building models that adapt to weather, occupancy, and other conditions. When performance deviates past a modeled threshold, the diagnostics determine the root of the problem and alert building operators.

Potential for Retrofit

This multilevel FDD approach could be applied to existing HVAC systems, especially as a BAS system feature, or included in new construction.

Potential Scope of Impact

Most commercial buildings would benefit from multilevel FDD if they featured several HVAC systems. Certain less complex cases such as buildings with simple packaged units and ductwork would be better suited for other types of FDD. Based on an analysis of its potential impact on HVAC systems in the U.S., this technology would save 0.132 Quads of natural gas, and 0.304 Quads of electricity per year.

Energy-Savings Performance

Katipamula et al. (2003) examined the robustness of the Whole Building Diagnostician program developed by Pacific Northwest National Laboratory to determine its capabilities in a variety of conditions. They estimated that a multilevel FDD system could decrease energy waste contributed to equipment malfunctions by up to 30%. By having a FDD system in place, service technicians can be better utilized as well.

Roth et al. (2005) discussed FDD systems which compare real-time operations to an energy-efficient model and evaluate performance across multiple HVAC systems. It is believed that this multilevel approach could save 20% on energy use if the detected faults were repaired.

The specific energy savings of installing a multilevel FDD system depend on the type, number, and age of equipment, the building heating/cooling energy usage, and the willingness of building operators to perform the suggested maintenance.

Cost Information

Roth et al. (2005) determined that the multilevel FDD system could be installed for \$.10-1.36/sq.ft. with a payback from 1-10 years. All systems require significant labor and software costs above the price of sensors. Because of this, larger systems have a more favorable payback by with limited added labor associated with the additional sensors.

Peak-Demand Reduction and other Benefits beyond Energy-Efficiency Gains

Multilevel FDD can reduce wastes associated with air-conditioning during peak-demand periods, although this varies with each application. Servicing equipment when it first shows a performance drop extends the life of equipment. Occupant comfort can improve when systems operate as designed after maintenance.

Technical Maturity and Recent Developments

This is an emerging technology with limited availability in the U.S. market today.

Barriers to Market Adoption

As with many FDD systems, the energy savings for a specific building are difficult to predict without extensive monitoring. These technologies only save energy if the building operators remedy the performance issues found through the FDD process. The first cost of these systems is high, but can be manageable for very large HVAC users. False alarms reduce the effectiveness of FDD systems.

Opportunities and Next Steps for Technology

Large commercial buildings that feature complex HVAC systems can benefit greatly by including multilevel FDD as part of regular maintenance programs. The FDD would direct technicians to immediate problems that affect system performance, helping to maintain optimal efficiency. BAS systems can readily add in the FDD sensors and algorithms in their control structures. Sensors using plug-and-play or wireless transmission reduce installation costs. Better dynamic modeling will prevent false alarms and can be tailored to meet the specific load profile of that building. Further field testing will reveal the strengths of multilevel FDD and build a database of successful case-studies.

References

Katipamula et al. 2003. “Enhancing Building Operations through Automated Diagnostics: Field Test Results.” In Proceedings of 2003 International Conference for Enhanced Building Operations.

Lan and Chen. 2007. “Application of Modeling and Simulation in Fault Detection and Diagnosis of HVAC Systems.” Proceedings: Building Simulation 2007. p 1299-1306.

Roth et al. 2005. “Energy Impact of Commercial Building Controls and Performance Diagnostics: Market Characterization, Energy Impact of Building Faults and Energy Savings Potential.” TIAX LLC. Reference No. D0180.

Schein and Bushby. 2005. “A Simulation Study of a Hierarchical, Rule-Based Method for System-Level Fault Detection and Diagnostics in HVAC Systems.” National Institute of Standards and Technology. NISTIR 7216.

Wu and Sun. 2010. “Multilevel Fault Detection and Diagnosis on Office Building HVAC Systems.” 2010 ACEEE Summer Study on Energy Efficiency in Buildings. p 3.362 – 3.373.

B.19 Nanofluids Enhanced Twisted Tape Heat Exchanger

Systems Impacted by Technology		Energy-Savings Performance	Technical Maturity
Fluid Heat Exchangers		0.03 Quads/yr	R&D(short-term)
Peak-Demand Reduction Potential	Non-Energy Benefits	Ease of Retrofit	Cost/Complexity
Low	Less Material/Refrigerant	High	Medium

Description of Technology

Heat exchangers (HX) for HVAC systems can be augmented by physical enhancements inside the pipe that increase the effectiveness of the working fluid. These passive structures add turbulence and vorticity to the fluid flow increasing the convective heat transfer (HT) coefficient. Twisted tape inserts placed within a circular tube have been shown to raise HT in both gas and liquid HXs. Small volumes of nanoparticles added to the working fluid boost HT even further. The major issue with placing any impediment in the flow is a rise in fluid pressure drop and pump work. Twisted tape inserts placed in nanofluid flow minimize friction and pressure losses while enhancing HT much higher than a smooth pipe HX.

Description of How Technology Saves Energy

The twisted tape insert raises HX efficiency by physically swirling the fluid, energizing the stream to turbulent flow. The increased mixing of the turbulent flow enhances the convective HT coefficient so that the capacity of the HX is raised without additional pump work. The nanoparticles suspended in the fluid reduce pressure losses by agitating the boundary layers close to the twisted tape surface. When agitated, the particles themselves significantly increase the effective surface area of the fluid and consequently the HT capacity of the HX.

Potential for Retrofit

This technology will be a component in high-efficiency replacement equipment. The nanofluid enhanced twisted tape needs to be optimized for each application.

Potential Scope of Impact

The twisted tape insert works for any heat exchanger using straight tubes and then nanoparticles can be suspended in refrigerant, water, or another working. Based on an analysis of its potential impact on HVAC systems in the U.S., this technology would save 0.03 Quads of electricity per year.

Energy-Savings Performance

Sunder et al. (2007) tested a single-phase water HX containing a twisted-tape insert with an Al₂O₃ nanofluid. They found a 28% increase in HX efficiency for the same mass flow rate.

Liu and Yu (2010) tested a liquid minichannel HX using an Al₂O₃ nanofluid over a range of concentrations. The found HT coefficient increases 10-20% over a range of concentrations and Reynolds numbers.

Yadav (2009) found a 40% HT enhancement by using a half-length twisted tape insert for a U-bend HX. It was also noted that the insert increased friction losses 1.3-1.5 fold.

Murugesan et al. (2009) improved HT by 41% using a twisted tape insert with trapezoidal cuts and friction factor more than doubled.

Cost Information

Twisted tape inserts have been used on water side HXs for years to enhance HT. Little is known about the costs of nanoparticles to increase HT.

Peak-Demand Reduction and other Benefits beyond Energy-Efficiency Gains

This technology reduces the HX size and amount of required refrigerant.

Technical Maturity and Recent Developments

This technology is not commercially available, with a few product development issues to be resolved through short-term R&D activities. Twisted tape inserts have been used previously to enhance convective HT, but nanofluids have not seen wide applications in this area. The exact combination of tape size and twist along with the nanofluid concentration determines the degree of system benefit. Each system type will require a different combination.

Barriers to Market Adoption

This technology has not proven to work with refrigerants or in two-phase flows. The nanoparticles used to enhance HT are still being developed.

Opportunities and Next Steps for Technology

Limited research into the use of twisted tape inserts or nanoparticles with refrigerants slows introduction with vapor compression systems. Water based heating/cooling systems will most likely see the first introduction of these technologies since the research has been focused in these areas. Further testing should determine possible scale buildup with these technologies in the pipe flow. Significant research is needed to determine the best orientation of the twisted tape insert in a pipe, as well as the optimal concentration of nanoparticles in the working fluid.

References

Liu and Yu. 2010. "Single-phase Thermal Transport of Nanofluids in a Minichannel." Department of Mechanical Engineering. University of Houston.

Murugesan et al. 2009. "Heat Transfer and Pressure Drop Characteristics of Turbulent Flow in a Tube Fitted with Trapezoidal-cut Twisted Tape Insert." International Journal of Academic Research. Vol. 1. No. 1. September 2009. p 123-128.

Noothong et al. 2006. "Effect of Twisted-tape Inserts on Heat Transfer in a Tube." The 2nd Joint International Conference on Sustainable Energy and Environment. A-030 (P).

Sarada et al. 2010. "Enhancement of Heat Transfer Using Varying Width Twisted Tape Inserts." International Journal of Engineering, Science and Technology. Vol. 2, No. 6, 2010. p 107-118.

Sundar et al. 2007. "Experimental investigation of Heat Transfer Enhancements with Al₂O₃ Nanofluid and Twisted Tape Insert in a Circular Tube." International Journal of Nanotechnology and Application. Vol. 1 No. 2, 2007. p 21–28.

Yadav, Anil Singh. "Effect of Half Length Twisted-Tape Turbulators on Heat Transfer and Pressure Drop Characteristics inside a Double Pipe U-Bend Heat Exchanger." Jordan Journal of Mechanical and Industrial Engineering. Volume 3, Number 1, March. 2009. p 17-22.

B.20 Optimized Heat Exchangers

Systems Impacted by Technology		Energy-Savings Performance	Technical Maturity
Vapor Compression Heat Exchangers		0.05 Quads/yr	R&D (short-term)
Peak-Demand Reduction Potential	Non-Energy Benefits	Ease of Retrofit	Cost/Complexity
Low	Less Refrigerant	High	Medium

Description of Technology

In vapor compression systems, fin-and-tube heat exchangers (HX) heat or cool the airflow distributed to building occupants. Air passes over the collection of refrigerant filled tubes to either gain or reject heat. The geometry of the HX can be optimized to reduce the energy requirements of the compressor or fan while maintaining capacity. Changing the spacing of fins, along with the number, size, and orientation of tubes can significantly improve system efficiency.

Description of How Technology Saves Energy

Lowering fin density and increasing tube spacing minimizes fan pressure drop and the subsequent fan energy use. Utilizing tubes with larger bends reduces the fluid resistance of the coil. With lower resistance, the compressor better maintains refrigerant flow and capacity while using less energy.

Potential for Retrofit

Advanced HXs could be retrofit into existing systems or in high-efficiency replacement equipment.

Potential Scope of Impact

Evaporators and condensers for vapor compression systems would benefit from this technology. Based on an analysis of its potential impact on HVAC systems in the U.S., this technology would save 0.05 Quads of electricity per year.

Energy-Savings Performance

Domanski et al. (2004) utilized software to evaluate refrigerant circuitry in HXs. The advanced designs found through their analysis could increase total system capacity by 2%.

NIST (2008) used computer based tools to reduce uneven airflow distributions in finned tube coils. Through the use of hi-resolution cameras during experimentation, a 5% increase in system efficiency can be realized during subsequent optimized HX designs.

Thermorise (2009) developed their patented DEEP heat transfer coil with various configurations featuring both fin and tube spacing modifications. Reductions of 19% in fan and 10% in compressor power showed a 20% decrease in total energy use in laboratory testing.

Cost Information

Primarily, costs will be borne in the design stage since manufacturing infrastructure and materials would not need to change. Changes in the amount of material used for the coils will depend on the specific design. No information on how the equipment cost would be affected has been offered.

Peak-Demand Reduction and other Benefits beyond Energy-Efficiency Gains

This technology would lower the refrigerant charge of vapor-compression equipment.

Technical Maturity and Recent Developments

This technology is not commercially available, with a few product development issues to be resolved through short-term R&D activities. Software and testing techniques can be applied in the product development stage. Large scale testing of HXs using the optimized coil designs has yet to occur.

Barriers to Market Adoption

Powerful computational fluid design (CFD) software or high speed visual equipment requires both time and expertise to test for various HX configurations. Even then, the multiple rounds of high-tech testing may not return expected efficiency improvements using the novel HX ideas. Changes to the primary HX components greatly alter system performance, and other efficiency measures require less upfront design work.

Opportunities and Next Steps for Technology

The advanced testing process needs to be fully established along with predictive software. A CFD software program which would allow for non-physical testing of new finned tube orientations would lower lab costs. Further development in software streamlining the computer design and optimization stage lowers the cost of full scale CFD analysis. Major testing of promising novel heat exchanger designs would facilitate manufacturers to apply the experimental findings.

References

Abdelaziz et al. 2010. "Novel Heat Exchanger Design Using Approximation Assisted Optimization." Presentation at SAE 2011 Automotive Alternate Refrigerant System Symposium.

ACHR News. 2010. "DEEP COIL: A New Energy Efficient Solution." Air Conditioning, Heating & Refrigeration News. March 29th, 2010.

Domanski et al. 2004. "An Optimized Design of Finned-Tube Evaporators Using the Learnable Evolution Model." HVAC&R Research. Vol.10 No.2 April 2004. p 201-211.

NIST. 2008. "NIST Helps Heat Pumps 'Go With the Flow' to Boost Output." NIST Tech Beat. January 23rd, 2008.

Thermorise Inc. 2009. Retrieved from <http://thermorisecoil.com/>

B.21 Passive Unsteady Airflow Mechanisms

Systems Impacted by Technology		Energy-Savings Performance	Technical Maturity
DX Condensers and Evaporators		0.08 Quads/yr	R&D (short-term)
Peak-Demand Reduction Potential	Non-Energy Benefits	Ease of Retrofit	Cost/Complexity
Low	Reduced Equipment Size	High	Medium

Description of Technology

In direct expansion (DX) cooling systems, the evaporator and condenser act as heat exchangers (HX) between the air and refrigerant working fluids. The capacity and efficiency of the cooling system depends on how well the HX transfers energy. Passive unsteady airflow mechanisms are modifications made to the HX to raise the overall heat transfer coefficient. The enhancements are integrated into the HX structure so that as air passes through, more heat is transferred to the fluid. These passive mechanisms can take the form of surface roughness, dimples, or vortex generating fins.

Description of How Technology Saves Energy

Passive enhancements trip the airflow as it passes over the HX surface from laminar to more turbulent boundary layers. The energized turbulent boundary layer creates an unsteady vorticity raising the overall heat transfer coefficient for the HX surface. Through these small changes in HX geometry, the temperature difference across the HX decreases, lowering the needed temperature lift provided by the compressor, resulting in higher system efficiency. The passive enhancements themselves do not require energy to function, but may increase fan usage across the HX.

Potential for Retrofit

Unsteady flow mechanisms will be embedded in high-efficiency equipment used for retrofit.

Potential Scope of Impact

Any DX system that uses an air/refrigerant HX can benefit from the heat transfer enhancements. Condensers will be the primary equipment to use this technology since the mechanisms may collect harmful condensation and ice on evaporators. Based on an analysis of its potential impact on HVAC systems in the U.S., this technology would save 0.075 Quads of electricity per year.

Energy-Savings Performance

Sanders (2005) found a 52% increase in heat transfer on a louvered HX by adding vortex generating fins.

Obrien et al. (2002) used vortex generating fins on a finned tube HX and found a 35% heat transfer increase.

Westphalen et al. (2006) analyzed current enhanced heat transfer technologies and found that for every 100% increase in heat transfer coefficient, there is a 10-15% savings in cooling system energy usage. The report also notes that this does not take into account the increased fan requirements.

Cost Information

Westphalen et al. (2006) proposed that these types of unsteady flow mechanisms either can be used to raise the EER, or reduce material costs of unitary equipment. Increased manufacturing costs can be expected with the HX structural modifications.

Peak-Demand Reduction and other Benefits beyond Energy-Efficiency Gains

By increasing system efficiency, equipment can be sized smaller for the same capacity.

Technical Maturity and Recent Developments

This technology is not commercially available, with a few product development issues to be resolved through short-term R&D activities. Optimization of HX, compressor, fan, and product enclosure will need to be done by manufacturers as part of product development.

Barriers to Market Adoption

The capital cost of changing manufacturing processes may be too high compared to using a conventional HX with larger surface area. Rising material costs may change this.

Opportunities and Next Steps for Technology

Condensing units for unitary DX air conditioners should be the most effective application with the least amount of potential issues. Research has been carried out on the academic level primarily, and will need to be applied to specific manufacturer products in order to enter the marketplace.

References

O'Brien et al. 2002. "Heat Transfer Enhancement For Finned-Tube Heat Exchangers With Vortex Generators: Experimental And Numerical Results." Idaho National Engineering and Environmental Laboratory. ID 83415-3885.

Sanders, Paul. 2005. "Effects of Louver Length and Vortex Generators to Augment Tube Wall Heat Transfer in Louvered Fin Heat Exchangers." Virginia Polytechnic and State University.

Westphalen et al. 2006. "Heat Transfer Enhancement." ASHRAE Journal Vol. 48, April 2006.

B.22 Permanent Magnet Motors

Systems Impacted by Technology		Energy-Savings Performance	Technical Maturity
Compressor/Fan/Pump Motors		0.42 Quads/yr	Comm. Available
Peak-Demand Reduction Potential	Non-Energy Benefits	Ease of Retrofit	Cost/Complexity
Low	Noise/Controllability	High	High

Description of Technology

Permanent magnet (PM) motors use specific ferrous magnets integrated in either the rotor or stator to produce many benefits over the typical induction motor. The use of imbedded magnets allows for a simpler mechanical design that runs quieter and with less vibration. A doubly salient permanent magnet (DSPM) motor uses two sets of poles for greater flux concentration and power density. This increases the motor output while maintaining the compact profile of a PM motor. These motors are used in conjunction with variable speed drives with their improved responsiveness and controllability. Also known as Brushless DC motors.

Description of How Technology Saves Energy

The high-energy permanent magnets eliminate excitation and friction losses found in a normal induction motor. From the use of these magnets, the motor also operates at lower temperatures reducing operational losses associated with excess motor heating. The controllability of PM motors allows for efficient part-load operation when applicable.

Potential for Retrofit

The PM motors would be an imbedded component in new high-efficiency replacement equipment. There will be instances where a direct motor swap would be possible as well.

Potential Scope of Impact

Motors can be found in most HVAC systems including fans, compressors, and pumps in fractional horsepower (hp) applications. Because of this, advances in motor efficiency would have a significant impact in overall energy consumption. Based on an analysis of its potential impact to HVAC systems in the U.S., this technology would save 0.42 Quads of electricity per year.

Energy-Savings Performance

Liao et al. (1995) tested a DSPM motor to have an efficiency of 90.5% compared to a similar induction motor of 75%.

Li and Lipo (1995) developed an advanced DSPM motor with an efficiency of 96.5%.

Cost Information

Sachs et al. (2002) examined the impact of PM motors compared to typical induction motors on the market. Even with a higher first cost (up to 3 times larger), the design and part-load efficiency gains save significantly on heating/cooling energy costs with a payback under 3 years.

Peak-Demand Reduction and other Benefits beyond Energy-Efficiency Gains

Quieter operation and increased controllability are added benefits of PM motors.

Technical Maturity and Recent Developments

This is a commercially available technology with low market penetration. Recent developments have raised the availability of PM motors from the fractional-hp to the multi-hp range.

Barriers to Market Adoption

PM motors experience high first cost due to the premium of the magnets and electronics which make up the sophisticated control equipment. Demagnetization caused by overheating either the surrounding environment or motor overload drops system efficiency.

Opportunities and Next Steps for Technology

PM motors will continue to gain a larger market acceptance as prices become lower. With wider applications of the DC motor technology, manufacturing volume of the magnets and power electronics will rise. The same technology which goes into motors for electric vehicles is found in PM motors used for HVAC. This will lead to more innovation in the multi-HP segment and lower costs overall.

References

Aydin and Lipo. "Field Weakening of Permanent Magnet Machines – Design Approaches." Wisconsin Electrical Machines and Power Electronics Consortium. University of Wisconsin.

Li and Lipo. 1995. "A Doubly Salient Permanent Magnet Motor Capable of Field Weakening." Wisconsin Power Electronics Center. University of Wisconsin. Research Report 95-25.

Liao et al. 1995. "A Novel Permanent Magnet Motor with Doubly Salient Structure." IEEE Transactions on Industry Applications. Vol.31, No. 5, September/October 1995. p 1069-1078.

Sachs et al. 2002. "Residential HVAC Fans and Motors Are Bigger than Refrigerators." Proceedings of the ACEEE 2002 Summer Study on Energy Efficiency in Buildings. 1.261.

B.23 Regular Maintenance

Systems Impacted by Technology		Energy-Savings Performance	Technical Maturity
All HVAC Systems		0.87 Quads/yr	Comm. Available
Peak-Demand Reduction Potential	Non-Energy Benefits	Ease of Retrofit	Cost/Complexity
Medium	Equipment Longevity	High	Medium

Description of Technology

HVAC systems require periodic maintenance to operate efficiently and prolong the lifetime of critical equipment. Building managers and occupants tend to respond only to system failures after they happen. This reactive approach proves more costly than preventive maintenance in both the near- and long-term. HVAC systems operate largely hidden from sight so malfunctions are not noticed unless there is a serious change in comfort. Regular inspection and preventive maintenance identifies and repairs system deviations before they become failures. Servicing HVAC systems regularly extends equipment lifetime, maintains peak efficiency, reduces system downtime, and provides better occupant comfort.

Description of How Technology Saves Energy

Regular maintenance saves energy by sustaining optimal system performance. Heat exchangers lose performance when dirt or scale accumulates on surfaces causing a drop in capacity and increased energy use. Fan belts wear over time, slip, and reduce system performance. Complicated controls are often changed unknowingly from their most efficient settings and never recalibrated. Equipment deteriorates and loses efficiency over time, but that process speeds up significantly without regular maintenance.

Potential for Retrofit

Regular maintenance applies to HVAC systems in existing buildings only.

Potential Scope of Impact

Virtually all HVAC equipment and systems could benefit from regular maintenance. Based on an analysis of its potential impact on HVAC systems in the U.S., this technology would save 0.263 Quads of natural gas, and 0.609 Quads of electricity per year.

Energy-Savings Performance

Piper (2009) discusses the importance of regular maintenance on HVAC systems. Maintained equipment is 15-20% more efficient than units left alone to deteriorate and lose performance.

Colorado Springs Utilities (2009) found a 15-20% increase in efficiency by regularly cleaning evaporator and condenser coils. HVAC systems with unmaintained controls are 5-30% less efficient.

Cost Information

ADM Associates Inc. (1999) found that yearly HVAC maintenance costs were \$.251-.457/sq.ft. and \$.094-.198/sq.ft. for buildings with and without in-house maintenance staffs. Service costs for a packaged rooftop unit are low until it is 10-15 years old. At this time it is worth considering new equipment if many costly repairs are needed.

Energy Market Innovations Inc. (2004) studied the costs and benefits of regular maintenance programs. They found that maintenance costs for a packaged rooftop unit are \$250-500 per year and varies with the number and age of the units.

Van Buskirk and Pearce (2010) implemented an HVAC maintenance process as part of utility sponsored efficiency programs. The maintenance saves on average \$340 per unit yearly.

Peak-Demand Reduction and other Benefits beyond Energy-Efficiency Gains

Besides energy efficiency, regular maintenance extends equipment lifetimes and reduces noise.

Technical Maturity and Recent Developments

This is a commercial available technology.

Barriers to Market Adoption

Energy savings through maintenance are tough to quantify without intrusive monitoring equipment. Because of this, building owners only budget for maintenance after repairs are needed. Building maintenance staff is often limited, and the time to regularly maintain each HVAC system component exceeds their capabilities.

Opportunities and Next Steps for Technology

Buildings with large or many packaged HVAC units would benefit most from regular maintenance. Gas and electric utility programs have supported regular maintenance of HVAC equipment for efficiency savings and peak-demand reduction. Advanced diagnostics and building management software can notify maintenance staff of any abnormalities in between tune-ups and increase the application of regular maintenance.

References

ADM Associates Inc. 1999. "HVAC Maintenance Costs." ASHRAE Research Project 929.

Colorado Springs Utilities. 2009. "White Paper #3 – Targeted Maintenance." April 30, 2009.

Energy Market Innovations Inc. 2004. "Market Progress Evaluation Report of the Small Commercial HVAC Pilot Program." Northwest Energy Efficiency Alliance. Report E04-135.

Hunt et al. 2010. "HVAC Energy Efficiency Maintenance Study." Southern California Edison. CALMAC Study ID SCE0293.01.

Jacobs, Pete. 2003. "Small HVAC Problems and Potential Savings Reports." Prepared for California Energy Commission. P500-03-082-A-25.

Piper, James. 2009. "HVAC Maintenance and Energy Savings." Facilitiesnet. Retrieved from <http://www.facilitiesnet.com/>.

Van Buskirk and Pearce. 2010. "Yes You Can! Achieving Quantity and Quality with Commercial HVAC Programs." ACEEE Summer Study August 2010.

B.24 Seasonal Thermal Energy Storage

Systems Impacted by Technology		Energy-Savings Performance	Technical Maturity
Hydronic Heating/Cooling		0.01 Quads/yr	Emerging
Peak-Demand Reduction Potential	Non-Energy Benefits	Ease of Retrofit	Cost/Complexity
Medium	Smaller Equipment	Low	High

Description of Technology

Thermal energy storage allows heating and cooling loads to be met by low-cost energy produced at a different time. In Northern climates, building operators can use the seasonally available solar or snow thermal energy for HVAC applications. Seasonal thermal energy storage (STES) collects abundant thermal energy in the summer and transfers it for use in the winter, and vice versa. Minimizing heat losses due to the relatively stable temperatures, underground, STES systems use groundwater directly in open-loop aquifer systems, or use the soil's thermal mass in closed-loop borehole or submerged tank systems.

Description of How Technology Saves Energy

The energy provided by solar hot water panels in the summer and snow/ice collectors in the winter is both abundant and low-cost. These thermal sources reduce the amount of fuel or electricity needed to provide heating/cooling instead of reducing the overall system load. The available thermal energy is stored for months to offset the load provided by conventional heating/cooling sources.

Potential for Retrofit

STES systems require either large underground storage tanks, or deep holes drilled into the ground. Detailed site analyses and necessary ancillary systems make STES applications difficult to implement for retrofit and new construction.

Potential Scope of Impact

Through the use of STES, conventional hydronic heating and cooling systems are reduced. STES systems sized to meet only a percentage of the total heating/cooling load, still require conventional equipment. Based on an analysis of its potential impact on HVAC systems in the U.S., this technology would save 0.01 Quads of natural gas, and 0.005 Quads of electricity per year.

Energy-Savings Performance

STES systems use low-cost available energy sources that offset the use of heating fuel or electricity. The amount of energy savings will vary significantly depending on the size of the system and the building loads.

Paksoy et al. (2004) state that STES reduces energy use by 20-30% for heating and 60-80% for cooling applications.

Zizzo and Kennedy (2010) found that implementing STES systems in the Toronto area would reduce energy use by 30-40% for space and water heating.

Cost Information

Roth and Brodrick (2009) discuss how the size and utilization of the storage system affects the economic performance of a STES system. The per-unit cost of the system decreases as both size and percentage of yearly energy use increases. The stored energy cost 2-20 times higher than natural gas.

Schmidt and Mangold (2003) surveyed STES systems in Germany and found a 300% cost premium for stored heating energy over natural gas.

Peak-Demand Reduction and other Benefits beyond Energy-Efficiency Gains

Peak demand caused by cooling will decrease according to the size and utilization of the STES system to the needed load. Zizzo and Kennedy (2010) state that peak demand of cooling systems can be reduced by 80-90%.

Technical Maturity and Recent Developments

This is an emerging technology with limited availability in the US market today. European countries have used STES provided by solar thermal panels for decades but still have not seen wide adoption. Northern European countries have implemented chilled water STES provided from snow/ice collection to provide cooling in the summer. This technology is also developing for pavement snow/ice removal in both the European and Asian markets. Recent research has shown the efficiency advantages of coupling an underground tank with borehole wells or with a phase-changing material.

Barriers to Market Adoption

High first cost, system complexity, unfamiliarity of designers, and size considerations have limited the application of STES.

Opportunities and Next Steps for Technology

Large institutional or commercial buildings could utilize heating/cooling STES in Northern U.S. climates where large amounts of winter snow or summer sun can be used at different times of the year. Costs of the thermal storage containers, borehole drilling, and solar thermal panels will decrease as those technologies become mature.

References

Lottner and Mangold. 2000. "Status of Seasonal Thermal Energy Storage in Germany." Terrastock 2000.

Paksoy et al. 2004. "Cooling in All Climates with Thermal Energy Storage." IEA FBF Conference – Cooling Buildings in a Warming Climate. June 2004.

Roth and Brodrick. 2009. "Seasonal Energy Storage." ASHRAE Journal. January 2009. p 41-43.

Schmidt and Mangold. 2006. "New Steps in Seasonal Thermal Energy Storage in Germany." Proceedings of Ecstock 2006: The Tenth International Conference on Thermal Energy Storage.

Zizzo and Kennedy. 2010. "Designing an Optimal Urban Community Mix for an Aquifer Thermal Energy Storage System." 2010 ACEEE Summer Study on Energy Efficiency in Buildings. p 11-253 – 11-264.

Zohoor and Moosavi. 2010. "Increase in Solar Thermal Energy Storage by using a Hybrid Energy Storage System." International Journal of Engineering and Applied Sciences. Vol. 6 No. 5. p 307-312.

B.25 Smaller Centrifugal Compressors

Systems Impacted by Technology		Energy-Savings Performance	Technical Maturity
Chiller Compressors (25-80 tons)		0.09 Quads/yr	Comm. Available
Peak-Demand Reduction Potential	Non-Energy Benefits	Ease of Retrofit	Cost/Complexity
High	Controllability/Noise	High	Medium

Description of Technology

Centrifugal chillers provide the most efficient cooling for vapor-compression chilled-water systems. While centrifugal compressors typically are used for systems with cooling loads over 100 tons, reciprocating, scroll, and screw compressors make up the small chiller market. Small oil-free centrifugal compressors bridge this gap and provide the energy-efficient technology for low-tonnage chillers. The compressor system consists of a centrifugal impeller, permanent magnet synchronous motor, magnetic bearings, and variable speed drive. These innovative components combine to provide controllability and energy efficiency with less vibration and noise in a compact unit.

Description of How Technology Saves Energy

The high-performance components of the small centrifugal compressor allow it to achieve higher efficiencies. The variable speed drive controls the compressor output to better match part-load conditions. The magnetic bearings replace mechanical gears and linkages, raising efficiency by connecting the centrifugal impeller directly with the motor. Additionally, the magnetic bearings eliminate the need for oil in the compressor which has been shown to reduce heat transfer efficiency by up to 35% (Payvar and Tatara, 1999).

Potential for Retrofit

This technology can be retrofit onto existing chiller systems or implemented as a component in high-efficiency packaged chillers.

Potential Scope of Impact

Reciprocating and screw compressors for chilled-water systems in the 25-80 ton range will be replaced by the small centrifugal compressors. Based on an analysis of its potential impact on HVAC systems in the U.S., this technology would save 0.09 Quads of electricity per year.

Energy-Savings Performance

Erpelding and Moman (2005) examined the installation of Danfoss Turbocor compressors in the California market. After installation, a 30-50% reduction in yearly energy usage was found. Citing the manufacturer's material, the small centrifugal compressor had improved efficiencies of 30%, 33%, and 40% over other centrifugal, screw, and reciprocating compressors respectively.

Diekmann et al. (2003) estimated a total energy savings of 15% for small centrifugal compressors and much higher efficiencies in part-load situations.

Danfoss (2011) advertises a part-load improvement of 33%, a 10-40% demand reduction, and a 40% total energy savings for certain installations.

Cost Information

Erpelding and Moman (2005) cite incremental cost increases of 33%, 45% and 15% over other commercially available centrifugal, screw, and reciprocating compressors respectively.

Diekmann et al. (2003) note that 75% of the system costs for the small centrifugal compressors consists of the high-speed motor and variable speed drive. Both of these technologies have reduced costs in recent years.

Peak-Demand Reduction and other Benefits beyond Energy-Efficiency Gains

Small centrifugal compressors are highly controllable due to the variable speed drive and have reduced noise and vibration compared to other compressors.

Technical Maturity and Recent Developments

This is a commercial available technology. Danfoss has been marketing its Turbocor small centrifugal compressor since the early 2000s and it has been implemented for compressor replacement or as a part of chillers offered by other manufacturers.

Barriers to Market Adoption

First cost for centrifugal compressors is always an issue but is overcome by the improved energy efficiency. Manufacturers of packaged chillers driven by reciprocating or screw compressors may resist introducing products with small centrifugal compressors because it would cut into their current product offerings.

Opportunities and Next Steps for Technology

Further development of packaged chillers utilizing the small centrifugal compressors will bring the optimized systems to market. The technical maturity of variable speed drives and high-speed motors will reduce their costs and make the small centrifugal compressor system more economical.

References

Danfoss Turbocor Compressors Inc. 2011. Retrieved from <http://www.turbocor.com>.

Diekmann et al. 2003. "Small Centrifugal Compressors." ASHRAE Journal. October 2003. p 67.

Erpelding and Moman. 2005. "Small Oil-Less Centrifugal Compressors: Bringing Energy Efficiency and Reduced Costs to Chiller Plants." 2005 ACEEE Summer Study on Energy Efficiency in Industry.

Payvar and Tatara. 1999. "Experimental Determination of the Effect of Oil on Heat Transfer with Refrigerants HCFC-123 and HFC-134a." ASHRAE Research Project 751-RP.

B.26 Small-Grooved Copper Tubes

Systems Impacted by Technology		Energy-Savings Performance	Technical Maturity
Heat Exchangers Using Copper Tubes		0.03 Quads/yr	Medium
Peak-Demand Reduction Potential	Non-Energy Benefits	Ease of Retrofit	Cost/Complexity
Low	Less Refrigerant/Material	High	Low

Description of Technology

Refrigerant-based cooling and heat pump systems pass a working fluid through various heat sources and sinks. To ensure safe, reliable, and efficient operation, the closed refrigerant circuit typically travels through either copper or aluminum tubes. Although copper has higher thermal conductivity, less-expensive aluminum is often used. Small-grooved copper tubes can provide superior heat transfer while reducing material costs.

Description of How Technology Saves Energy

The grooved tubes provide higher efficiency than smooth tubes because of a surface-to-volume ratio and enhanced fluid agitation. The volume of a tube is strictly determined by its diameter and wall thickness. A smooth tube has a surface area based on the circumference of its inner diameter. Helically rifling the tube, or adding grooved teeth greatly increases the internal surface area of a tube without significantly changing its volume, resulting in better heat transfer. The rifled or grooved tube also trips the fluid from laminar to turbulent flow creating better heat transfer through fluid agitation.

Potential for Retrofit

Upgrading copper tubes in existing equipment is unrealistic. Rather, the smaller grooved copper tubes will be a component of the high-efficiency replacement equipment.

Potential Scope of Impact

The enhanced copper tubes can be part of any refrigerant based heat exchanger. Based on an analysis of its potential impact on HVAC systems in the U.S., this technology would 0.03 Quads of electricity per year.

Energy-Savings Performance

Abedin and Lampinen (2005) experimentally found that a rough copper tube had a 10-15% increase in heat transfer coefficient over a smooth tube of similar diameter.

Yang et al. (2010) tested 9.52 mm smooth and 5mm inner-grooved copper tubes for their heat transfer qualities. The small-grooved tube had a 15% higher heat transfer coefficient for the same amount of copper.

Cost Information

Yang et al. (2010) tested 9.52 mm smooth and 5mm inner-grooved copper tubes for their heat transfer qualities. The small-grooved tube used 41.8% less raw copper for essentially the same heat transfer.

Shunyi et al. (2010) tested a 7mm smooth and 5mm inner-grooved copper tubes in an evaporator to test their heat transfer efficiencies. The evaporator with the small-grooved tubes used 43% less raw copper for slightly higher heat transfer.

Manufacturing cost for the grooved copper pipes will be potentially higher because of the added extrusion complexity for the inner enhancements.

Peak-Demand Reduction and other Benefits beyond Energy-Efficiency Gains

With more efficient smaller tubes, less harmful refrigerant needs to be used.

Technical Maturity and Recent Developments

This is an emerging technology with limited availability in the US market today. The rifled and grooved copper tubes have been used in Japan since the late 1970s (Houfuku, 2007). U.S. manufacturers have largely chosen smooth aluminum to reduce material costs over the years. Goodman Manufacturing has switched to a 5mm grooved “SmartCoil” for many of its products, and showcases the units for using 25% less refrigerant and 15% less volume (Goodman, 2008).

Barriers to Market Adoption

The fluctuating price of copper will always be an issue, but the efficiency gains from the grooved tubes make them economically feasible. Pressure drop and compressor work increase with smaller tubes, but this can be balanced by using more branches with shorter pipe lengths in the heat exchanger.

Opportunities and Next Steps for Technology

Additional testing with various refrigerants is needed. Optimization of the inner tube enhancement geometry is needed from both a manufacturing, and efficiency standpoint.

References

Ambedin and Lampinen. 2005. “Heat Transfer Coefficient Measurements for Smooth and Rough Tubes at Low Reynolds Number.” International Conference on Mechanical Engineering 2005. ICME-TH-45.

Goodman Air Conditioning and Heating. 2008. “The Future of Air Conditioning... Smaller is Smarter!” Goodman Manufacturing Company, LP. <http://www.goodmanmfg.com>.

Houfuku, Mamoru. 2007. “Development Trends in Inner-grooved Tubes in Japan.” Hitachi Cable Review No 26. August 2007.

Shunyi et al. “Application of Small Diameter Inner-Grooved Copper Tubes in Air-Conditioning Systems.” Presented at Second IIR Workshop on Refrigerant Charge Reduction. June 2010.

Yang et al. "Performance and Cost Analysis and Research of Air-Cooled Heat Exchanger Using Small Diameter Copper Tubes." Presented at Second IIR Workshop on Refrigerant Charge Reduction. June 2010.

B.27 Switched Reluctance Motors

Systems Impacted by Technology		Energy-Savings Performance	Technical Maturity
Fans, Pumps, Compressors		0.42 Quads/yr	Comm. Available
Peak-Demand Reduction Potential	Non-Energy Benefits	Ease of Retrofit	Cost/Complexity
Low	Size/Weight/Controllability	High	Low

Description of Technology

Operating at part-load conditions is a modern energy saving strategy for HVAC systems. To do this, the fans, pumps, and compressors throughout the HVAC system need to run efficiently at non-peak settings. Switched reluctance DC motors (SRM) have been in use since the 1800s but have not seen wider application due to their higher noise and lower peak efficiency than other motor types. The rise of low-cost power electronics allows SRMs to become quieter with greater controllability. Because of this, SRMs become an attractive motor choice for HVAC systems looking for high-efficiency during part-load conditions.

Description of How Technology Saves Energy

SRMs match output directly as needed with their simple and reliable design. The stacked steel laminate sheets of the rotor turn to align with the excited stator pole in the presence of current. The rotor twists to align with the excited pole and this process circulates the stator to run the motor. This simple electrical machine is compact, and cheaper to make than other motors. Electronic controls have mitigated the sound and vibration issues that plagued earlier designs. Rotor magnets used on other motors lose efficiency quickly outside of design conditions where SRMs have a wider speed range of efficient operation.

Potential for Retrofit

SRMs will be an integrated part in high-efficiency replacement equipment as well as for retrofit in buildings where individual fan/pump motors were installed originally.

Potential Scope of Impact

Motor applications which require part-load controllability will benefit from the SRM. Based on an analysis of its potential impact on HVAC systems in the U.S., this technology would save 0.42 Quads of electricity per year.

Energy-Savings Performance

Panda and Ramanarayanan (2007) found that SRMs are 30% more efficient than induction HVAC motors when part-load analysis is included.

Teschler (2008) state that SRMs provide 90% of the peak efficiency of conventional HVAC motors over a much wider speed range when other motors' efficiency falls drastically. The SRMs consume 50% less electricity in the power conversion process used by variable speed drives (VSD) to provide controllability for induction motors.

Cost Information

Due to their simple and compact design, SRMs are known throughout the industry to have low manufacturing costs.

Peak-Demand Reduction and other Benefits beyond Energy-Efficiency Gains

No rare earth permanent magnets are used with SRMs. Additionally, these motors are smaller, weigh less, and can be scaled for high-hp applications.

Technical Maturity and Recent Developments

This is a commercial available technology. Many motor manufacturers are introducing SRMs to the HVAC market as an alternative to VSDs for induction motors.

Barriers to Market Adoption

The popularity of retrofitting VSDs with existing equipment limits the application of SRMs.

Opportunities and Next Steps for Technology

SRMs need to be paired with packaged HVAC equipment to determine the performance benefits over other forms of fan, pump, and compressor controllability. Larger production numbers will reduce the price of SRMs.

References

Panda and Ramanarayanan. 2007. "Reduced Acoustic Noise Variable DC-Bus-Voltage-Based Sensorless Switched Reluctance Motor Drive for HVAC Applications." IEEE Transactions on Industrial Electronics, Vol. 54, No. 4, August 2007. p 2065-2078.

Texas Instruments Europe. 1997. "Digital Signal Processing Solutions for the Switched Reluctance Motor." Texas Instruments Incorporated. Literature No. BPRA058

Teschler, Leland. 2008. "The Switch to Switched Reluctance." Machine Design. December 11, 2008.

B.28 Triple Effect Absorption Chiller

Systems Impacted by Technology		Energy-Savings Performance	Technical Maturity
Traditional Absorption Chillers		0.07 Quads/yr	R&D (short-term)
Peak-Demand Reduction Potential	Non-Energy Benefits	Ease of Retrofit	Cost/Complexity
Low	Low Maintenance	Medium	Medium

Description of Technology

Triple-effect absorption chiller system consists of a double-effect lithium bromide/water cycle with an added high-temperature, high-pressure generator. The system includes three generators, with one generator each at a high, medium, and low temperature.

Description of How Technology Saves Energy

According to Mori, et al. (2003), triple-effect absorption chiller systems achieve a cooling COP higher than that of a double-effect system “by using gas heating or some other form of heat source to heat the high-temperature generator and using the high-temperature heat as it cascades downward through the absorption cycle”.

Potential for Retrofit

This technology can be retrofit in situations that are suitable for absorption cooling. Due to the long lifetimes of absorption cooling systems, triple-effect absorption chillers would primarily be for new installations.

Potential Scope of Impact

This technology would replace conventional chillers. Based on an analysis of its potential impact to HVAC systems in the U.S., this technology would save .006 Quads of natural gas, and .059 Quads of electricity per year.

Energy-Savings Performance

Mori, et al. (2003) reports that the Japan Gas Association (JGA) developed a 527 kW prototype triple-effect absorption chiller system that achieved a cooling COP of 1.49. JGA then leverage the results of this initial prototype testing to develop a larger, 1,054 kW prototype system that reached a cooling COP of 1.60.

Cost Information

Like other absorption cooling systems, triple-effect absorption chillers are economical if the cost of thermal energy is lower compared to the electricity for a conventional vapor compression chiller. Triple-effect systems require high temperature heating input to operate the third stage of absorption. Because of this, the complexity of the chiller as well as the materials needed to operate in such a corrosive high temperature environment raise the cost of the triple-effect absorption chiller. The efficiency gains of the triple-effect chiller may outweigh these costs, but should be determined for each potential application.

Peak-Demand Reduction and other Benefits beyond Energy-Efficiency Gains

This technology is expected to have a modest peak-demand reduction impact, since it would reduce cooling energy consumption. Absorption cooling typically has lower maintenance requirements and can utilize low grade waste heat where available.

Technical Maturity and Recent Developments

This technology is not commercially available, with a few product development issues to be resolved through short-term R&D activities.

Japan Gas Association is collaborating with absorption chiller system manufacturers, including Daikin Industries, to evaluate the performance of prototype systems [Mori, et al., (2003)]. The aim of the project is “to perform cycle simulations, to perform evaluations of corrosiveness, to evaluate the performance of prototype systems, and to develop policies regarding means of dealing with safety regulations and other types of regulations”. Through the project, each manufacturer will develop its own prototype design based on their own different solution flow system currently used in their commercially available double-effect system products. However, Daikin Industries is developing a new flow system optimized for triple-flow system instead of leveraging the existing system. The prototype systems are expected to have cooling capacities in the range of 352 kW to over 1,000 kW.

Barriers to Market Adoption

Quantifiable performance data, including expected energy savings, is not yet available. In addition to the ongoing prototype demonstration with Japan Gas Association, the technology would require a series of field demonstrations before the technology can gain acceptance in the industry and from the customers.

Opportunities and Next Steps for Technology

Next steps for the technology would include follow-on prototype demonstration as necessary, depending on the outcome of the ongoing efforts in Japan, and field testing and demonstration of the technology’s performance in a variety of operating conditions.

References

Mori, K., Oka, M., and Ohhashi, T., 2003. “Development of Triple-Effect Absorption Chiller-Heater”. Japanese Gas Association.

B.29 Thermal Energy Storage System in Rooftop Units

Systems Impacted by Technology		Energy-Savings Performance	Technical Maturity
Packaged A/C Units		0.03 Quads/yr	Emerging
Peak-Demand Reduction Potential	Non-Energy Benefits	Ease of Retrofit	Cost/Complexity
High	Distributed Energy Resource	High	Medium

Description of Technology

Thermal energy storage reduces peak demand and utilizes operational savings offered by favorable time-of-use electricity (ToU) rates for large chilled water commercial cooling systems. The same principals can be used on smaller 5-20 ton packaged A/C units to achieve energy efficiency. The unitary thermal storage system (UTSS) consists of a separate charging/condensing unit and connects with an evaporator coil in a packaged air-handler. The UTSS creates cooling at night for use during the day achieving a sizable peak-demand reduction with minimal efficiency loss.

Description of How Technology Saves Energy

Besides reducing peak demand and electricity costs under ToU rate structures, the UTSS saves energy by its alternative operation cycle during the night. The lower nighttime ambient temperatures raise system efficiency by improving condenser performance. Since the A/C unit does not run during less-efficient daytime conditions, the unit (especially the compressor) can be downsized while meeting the same cooling load. Instead of cycling many times per day to provide cooling, the A/C unit cycles only once during nighttime charging. The UTSS has an efficiency loss in thermal conversion, but the operational efficiency improvements equal or exceed these losses.

Potential for Retrofit

The UTSS charging/condensing unit and the specialized evaporator coil can be retrofit to existing packaged systems. New packaged equipment is available with the ice-cooling coil factory installed for easy installation.

Potential Scope of Impact

Packed A/C equipment in the 5-20 ton range in areas with high demand or ToU electricity rates will benefit from the UTSS. Based on an analysis of its potential impact on HVAC systems in the U.S., this technology would save 0.03 Quads of electricity per year.

Energy-Savings Performance

The difference between the day and night operating efficiency of the A/C unit determines the total system performance and will vary across applications.

The City of Anaheim Public Utilities Department (2005) installed a UTSS on a continuous-use fire house and found a 3.5% HVAC system savings during the trial period.

Willis and Parsonnet (2010) detailed the energy savings due to the nighttime operation of a UTSS. A 5-20% energy savings is achieved by downsizing A/C units once they no longer operate during peak hours. Eliminating cooling system cycling reduces energy use by 5-9%.

Cost Information

This is a new technology entering the marketplace with a subsequently high cost due to low-volume production. Installing a UTSS to a factory enabled A/C unit saves 60% on installation costs compared to existing A/C equipment. In the City of Anaheim Public Utilities Department (2005) test case, a pre-production unit cost \$10,000 to serve a 5 ton packaged system. Currently the technology is only offered to utilities as a distributed energy resource solution in favorable markets. Because of this, the price of the units is negotiated for each utility-scale application and no data is readily available for an individual unit price.

Peak-Demand Reduction and other Benefits beyond Energy-Efficiency Gains

The City of Anaheim Public Utilities Department (2005) found a 12% peak-demand reduction at their installation. Ice Energy (2011) has seen a 25% demand reduction in some installations, but each application will vary.

Since the system primarily runs during off-peak periods, packaged cooling equipment can be downsized for savings to both first and operating cost. There are numerous other benefits for utilities to use this technology including avoided capacity, and reduction of peak losses.

Technical Maturity and Recent Developments

This is an emerging technology with limited availability in the U.S. market today. Ice Energy has developed the UTSS and demonstrated its advantages to electric utilities, manufacturers and large building operators. Trane and Carrier both offer packaged A/C units with specialized cooling coils designed to accommodate UTSS. Utilities include UTSS in their incentive programs to reduce peak demand on the electrical grid caused by A/C. The Southern California Public Power Authority (SCPPA) began a program to roll out over 6,000 Ice Energy systems for a 53 MW avoided-cost savings (LaBella, 2010).

Barriers to Market Adoption

This technology is only practical in areas which have high demand or ToU electricity rates. Ice Energy does not sell units to building owners but only to utilities. First costs are high for situations where UTSS is paired with existing equipment. Retrofit projects using equipment with factory installed UTSS capabilities minimize upfront costs. Predicting energy savings with UTSS is difficult because of the limited body of knowledge. The additional space requirement may pose a problem in certain situations.

Opportunities and Next Steps for Technology

With the majority of commercial buildings utilizing packaged A/C systems, this technology should have wide acceptance in areas that offer the financial incentive to do so. The economic viability of this technology requires high demand charges, ToU electricity rates, or utility

incentives. Information gained from the increased number of installations should allow system designers to better predict UTSS energy savings and system performance.

References

City of Anaheim Public Utilities Department. 2005. "Application of a Small-Scale Thermal Energy Storage System." American Public Power Association Demonstration of Energy-Efficient Developments. July 2005.

Ice Energy. 2011. Retrieved from <http://www.ice-energy.com/>.

LaBella, Jeanne. 2010. "Public Power Daily: SCPPA to Rollout 53-MW Storage Project." January 27, 2010. Retrieved from <http://www.ice-energy.com/content10256>.

R.W. Beck. 2011. "Ice Bear Energy Storage System Electric Utility Modeling Guide." Developed for Ice Energy. February, 2011.

Willis and Parsonnet. 2010. "Energy Efficient TES Designs for Commercial DX Systems." ASHRAE Transactions. OR-10-016. p 147-156.

B.30 Variable Blade Pitch

Systems Impacted by Technology		Energy-Savings Performance	Technical Maturity
Large Supply/Return and Cooling Tower Fans		0.04 Quads/yr	Comm. Available
Peak-Demand Reduction Potential	Non-Energy Benefits	Ease of Retrofit	Cost/Complexity
Low	Noise Reduction	Medium	Low

Description of Technology

Variable pitch fan blades automatically change the fan geometry to optimize the desired airflow. The pitch of the blade determines the fan efficiency and airflow characteristics. Normally fan blades are fixed position so that the only way to modulate the airflow volume would be through changing motor speed. The blades adjust either through pneumatic or electronic controller located in the fan hub. Designers use computational fluid dynamics (CFD) software to find optimal pitch angles for the necessary conditions.

Description of How Technology Saves Energy

By controlling fan blade pitch, the fan airflow performance can be matched to the load while maintaining the fan motor at an efficient setting. Excess airflow volume consumes unnecessary electricity and changing the motor output can greatly decrease efficiency in some instances. Variable blade pitch fans remain at high efficiency over a wide range of conditions for specific temperature control applications.

Potential for Retrofit

Variable pitch blade controllers can be retrofit to existing equipment with axial fans only. Larger fans will see the airflow control benefits more than smaller fans and are the primary target of manufacturers.

Potential Scope of Impact

This technology will impact large fan systems in supply/return air ducts and cooling towers. Based on an analysis of its potential impact on HVAC systems in the U.S., this technology would save 0.04 Quads of electricity per year.

Energy-Savings Performance

Flexxaire (2010) developed variable pitch fans for large transportation cooling needs and states that fan energy consumption decreases by 30+%.

Monroe (1993) states that variable pitch fans on a cooling tower reduce consumption by 50%.

Cost Information

Monroe wrote a number of papers for the fan manufacturer Hudson Products Corp. One titled “Consider Variable Pitch Fans” outlines the expected payback of a variable pitch system vs. a

typical fixed fan configuration. From this study, the increased first cost of the variable pitched blades was recovered within one year of operation due to higher efficiency.

Peak-Demand Reduction and other Benefits beyond Energy-Efficiency Gains

Fan noise decreases in many instances.

Technical Maturity and Recent Developments

This is a commercial available and mature technology but has not seen wider use due to the rise of variable speed drives (VSD). Both systems reduce the airflow of fans and the power that they consume. VSDs modulate the motor speed while variable blades change the fan configuration.

Barriers to Market Adoption

VSDs are a viable option for modulating fans and many other motorized HVAC systems. Variable pitch fan systems have reliability issues with the pitch actuators resulting in a constant need for readjustment and attention.

Opportunities and Next Steps for Technology

Variable pitch fan blades seem to have a future only for very large fan applications (10 ft. and over). The commercial availability and familiarity with VSDs has limited their application since VSDs cover more components than just fans.

References

Flexxaire. Retrieved from <http://www.flexxaire.com>

Monroe, Robert. 1993. "Minimizing Fan Energy Costs, Parts 1 and 2." Hudson Products Corporation, Houston, Texas. Reprinted from Chemical Engineering Cost File, 1993

Monroe, Robert. 1980. "Consider Variable Pitch Fans." Hudson Products Corporation, Houston, Texas. Based on material originally presented at the 19th ASME-AICHe Heat Transfer Conference, Orlando, Florida

United Nations Environmental Programme. 2006. "Electrical Energy Equipment: Fans and Blowers." Energy Efficiency Guide for Industry in Asia.

B.31 Variable Refrigerant Volume Systems (VRV/VRF)

Systems Impacted by Technology		Energy-Savings Performance	Technical Maturity
Building HVAC Systems		0.19 Quads/yr	Comm. Available
Peak-Demand Reduction Potential	Non-Energy Benefits	Ease of Retrofit	Cost/Complexity
Low	Zonal Control, Noise	Medium	Medium

Description of Technology

Used extensively outside of the U.S. for over 25 years, variable refrigerant volume/flow (VRV/VRF) systems are ductless split heat pump systems with improved controllability. Like a regular direct expansion (DX) split system, VRV uses an indoor evaporator and outdoor condenser but without the use of extensive distribution ducts. Each indoor unit contains an electronic liquid expansion valve to control the supply of refrigerant to match the space conditioning load. Many of these indoor units can be linked together to an outdoor condenser through a single refrigerant loop. The VRV units can either be single setting (heating or cooling only) or dual setting heat recovery units (heating or cooling simultaneously to different zones). VRV systems bring efficient heat pump technology and increased zonal comfort to building occupants.

Description of How Technology Saves Energy

VRV reduces building energy use in a number of ways compared to conventional ducted DX or chilled water cooling systems. Distribution losses are diminished since VRV systems are typically ductless and located in the conditioned space. VRV units contain high efficiency parts such as modulating fan drives, variable speed inverter driven compressors, and multiple compressors for staged performance. For heat recovery units, waste heating/cooling energy is used to precondition refrigerant flows, reducing compressor usage. All of these features combine for considerably improved part-load performance compared to typical equipment.

Potential for Retrofit

For buildings receiving air-conditioning for the first time, VRV systems are attractive options. In buildings with existing cooling systems, replacing ducts and water piping with VRV distribution piping can be problematic.

Potential Scope of Impact

Packaged DX and chilled water systems heating and cooling systems would be replaced by VRVs. Based on an analysis of its potential impact on HVAC systems in the U.S., this technology would save 0.19 Quads of electricity per year.

Energy-Savings Performance

Goetzler (2007) discussed the advantages of VRV systems in certain building applications. VRV systems can achieve 30% higher efficiency through improved part-load operation, and eliminating duct losses.

Hitachi (2008) discovered a 40% COP improvement over conventional Hitachi equipment when using a similar sized VRV system.

Amarnath and Blatt (2008) surveyed literature on VRV use in commercial buildings. They found a 10-60% HVAC energy savings for buildings using VRV systems. They noted that savings varied with building climate and occupant use.

Cost Information

Goetzler (2007) stated that first cost will depend on each building application, but a 5-20% cost premium can be expected. For projects where ductwork or chillers may pose an installation issue, VRV can be cheaper to use.

Amarnath and Blatt (2008) found that VRV systems typically have higher first costs of 8-16% for chilled water, and 30-50% for packaged DX equipment.

Peak-Demand Reduction and other Benefits beyond Energy-Efficiency Gains

The efficiency improvements of VRV occur during off-peak performance. VRV systems improve occupant comfort by providing simultaneous heating or cooling zones as needed. VRV systems are quiet since the compressors are located in the condensing unit outdoors, and there are no ducts to propagate fan and airflow noise.

Technical Maturity and Recent Developments

This is a commercial available technology. In recent years, overseas manufacturers have either expanded into the U.S. or partnered with domestic manufacturers to market VRV systems to U.S. customers.

Barriers to Market Adoption

Like all heat pump systems, VRVs lose heating efficiency as outdoor temperatures near freezing. Currently there are no VRV systems that offer a dual-fuel approach and use natural gas as a backup heating source. For many buildings, installing replacement packaged DX or chiller equipment is less complicated than VRVs. Since VRVs only provide heating and cooling, a separate ventilation system is needed. Building operators and designers often fear refrigerant leakage from the long piping.

Opportunities and Next Steps for Technology

The first cost of VRVs will become more attractive as their high-efficiency components drop in price when used in other HVAC systems. High-rise buildings or those which require many separate zones with individual controls (such as hospitals) are ideal locations for VRV systems. Test studies performed across a number of climate regions should prove the viability of VRVs in the U.S.

References

Air Conditioning & Heat Pump Institute. 2010. "VRV/VRF Variable Refrigerant Volume (or Flow) Technology." Institute of Refrigeration. April, 2010.

Amarnath and Blatt. 2008. "Variable Refrigerant Flow: An Emerging Air Conditioner and Heat Pump Technology." 2008 ACEEE Summer Study on Energy Efficiency in Buildings. p 3-1 – 3-13.

Daiken. 2005. "VRV Variable Refrigerant Volume – Intelligent Air-Conditioning Technology." Daiken Industries, Limited. PCVUSE06-04C.

Goetzler, William. 2007. "Variable Refrigerant Flow Systems." ASHRAE Journal. April, 2007. p 24-31.

Hitachi. 2008. "Set-Free FSN – Variable Refrigerant Flow Air Conditioning Systems." Hitachi Appliances, Inc. HR-E568T.

Zhou et al. 2006. "Module Development and Simulation of the Variable Refrigerant Flow Air Conditioning System under Cooling Conditions in Energyplus." Proceedings of the Sixth International Conference for Enhanced Building Operations. HVAC Technologies for Energy Efficiency Vol.IV-1-2. ESL-IC-06-11-80.

B.32 Water-Cooled Condensers for Unitary Equipment

Systems Impacted by Technology		Energy-Savings Performance	Technical Maturity
Unitary DX A/C		0.06 Quads/yr	Emerging
Peak-Demand Reduction Potential	Non-Energy Benefits	Ease of Retrofit	Cost/Complexity
Low	Equipment Flexibility	Medium	High

Description of Technology

Packaged or unitary HVAC equipment leaves the factory ready for installation, and has become the primary provider of HVAC for low-rise U.S buildings. The majority of unitary direct expansion (DX) systems use air as the condenser cooling fluid. Because of its higher density, water is a more efficient heat transfer fluid than air, but traditionally has been used only for large chiller systems. Manufacturers developing water-cooled unitary condensers have found improved year-round performance with significant energy savings in initial testing. The condenser can be linked with either the local water system, water heater, or a cooling tower.

Description of How Technology Saves Energy

Water-cooled condensers benefit from the larger heat transfer capacity of water. Despite the requirements of additional pumps and fans, the added efficiency of the water-cooled system outweighs these auxiliary components. Air-cooled systems lose efficiency and capacity with ambient temperature fluctuations where inlet water remains constant over a small temperature range. Heat recovery methods are more effective as well with water-based systems. Shorter refrigerant pipe lengths lower compressor energy while reducing the leakage rate and total refrigerant charge.

Potential for Retrofit

Water-cooled unitary condensers will be part of replacement equipment in retrofit situations for DX systems.

Potential Scope of Impact

Packaged rooftop DX or VRV/VRF systems can share a water-cooled condenser line among many units. Light commercial split systems using water-cooled condensers are also under development. Based on an analysis of its potential impact on HVAC systems in the U.S., this technology would save 0.06 Quads of electricity per year.

Energy-Savings Performance

Hu and Huang (2005) created a prototype water-cooled split air-conditioning system that saw a COP increase of 17% over a similar air-cooled system.

Lee and Chen (2006) tested a water-cooled prototype over various conditions. They found that their water-cooled split system increased efficiency by over 25%.

Daiken (2010) has developed a water-cooled VRV/VRF system that is 30% more efficient than their air-cooled VRV/VRF system.

Cost Information

Generally water-cooled equipment has higher first and lower operating costs compared to air-cooled systems. Carrier (2005) outlines the differences in cost and function for water vs. air-cooled chillers. They do note that each building location, load schedule, and water supply will affect the analysis.

Peak-Demand Reduction and other Benefits beyond Energy-Efficiency Gains

The condenser can pump water to any location needed inside a building to act as a heat sink for the evaporated refrigerant. Because the refrigerant line does not need to run outdoors, the evaporator unit can be placed virtually anywhere in the building.

Technical Maturity and Recent Developments

This is an emerging technology with limited availability in the U.S. market today. Water-source heat pumps and chilled water systems have been used for decades in the U.S. market. At the 2011 AHR Expo, Rheem introduced a hybrid air-and-water packaged unit for customers that require considerable simultaneous cooling and hot water capabilities, such as restaurants.

Barriers to Market Adoption

Water-cooled equipment will have higher first cost and system complexity than air-cooled systems. The higher efficiency of water-cooled equipment leads to lower operating costs in places with suitable water conditions or comfort requirements. Nevertheless, building operators may be reticent to switch to water-cooled systems in retrofit situations, especially when there are high efficiency air-cooled systems on the market.

Opportunities and Next Steps for Technology

Buildings that require many packaged rooftop units will have the easiest integration of the necessary water pipes and cooling towers. In places where space is tight, the water-cooled VRV/VRF systems will be advantageous. A water-source heat pump cooled through the city water supply was also developed by Technibel (2009) for use in residential and light-commercial applications. Applying the condenser heat recovery techniques of industrial facilities to smaller commercial equipment can lead to greater total system efficiency and lower energy usage.

References

Carrier Corporation. 2005. "Commercial HVAC Equipment: Air-cooled Chillers." Technical Development Program.

Daiken AC. 2010. "VRV-WIII Water Cooled." Daiken Industries, Limited.
<http://www.daikenac.com>

Hu and Huang. 2005. "Study of a High Efficiency Residential Split Water-cooled Air Conditioner." Applied Thermal Engineering 25, 2005. p 1599-1613.

Key, Brian. 2008. "Heat Recovery from Chilled Water Systems." Carrier Corporation. April 2008. Publication no. 04-581025-01.

Lee and Chen. 2006. "Applying a Domestic Water-cooled Air-conditioner in Subtropic Cities." HVAC Technologies for Energy Efficiency, Vol. IV-9-4. Proceedings of the Sixth International Conference for Enhanced Building Operations, Shenzhen, China, November 6 - 9, 2006

McIver, Terry. 2011. "Rheem Unveils New Look at AHR Expo." Contracting Business. Feb. 2nd, 2011. Retrieved from <http://contractingbusiness.com/>.

Technibel. 2009. "Single Package Console Unit Reve." 2009 Technibel CATALOGUE Air to Water and Air to Air Heating and Air-conditioning Systems.

Appendix C Technical Energy-Savings Potential of the 57 Technology Options (Except Early-Stage Technologies)

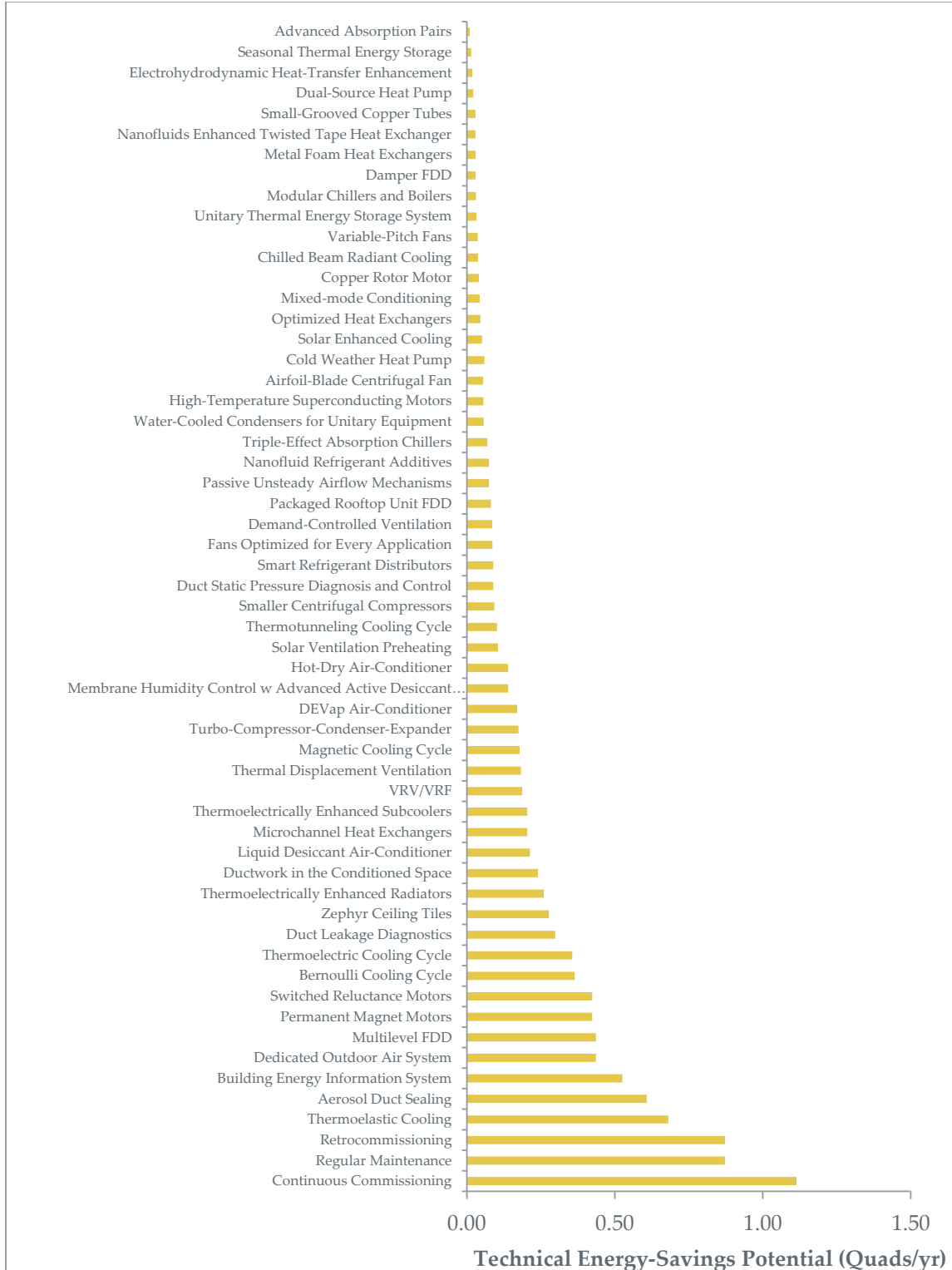

U.S. DEPARTMENT OF
ENERGY

Energy Efficiency &
Renewable Energy

DOE/EE-0846 • September 2011

Printed with a renewable-source ink on paper containing at least 50% wastepaper, including 10% post-consumer waste.