

Renaissance in Flow-Cell Technologies

Recent Advancements and Future Opportunities



Mike Perry
Project Leader, Electrochemical Systems
United Technologies Research Center

Grand Challenges in Electrical Energy Storage (EES)

SCALE & COST: *Want to go from Wh to kWh to MWh...*

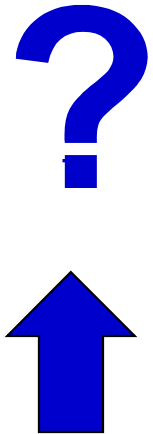
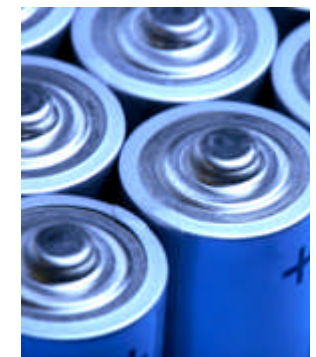
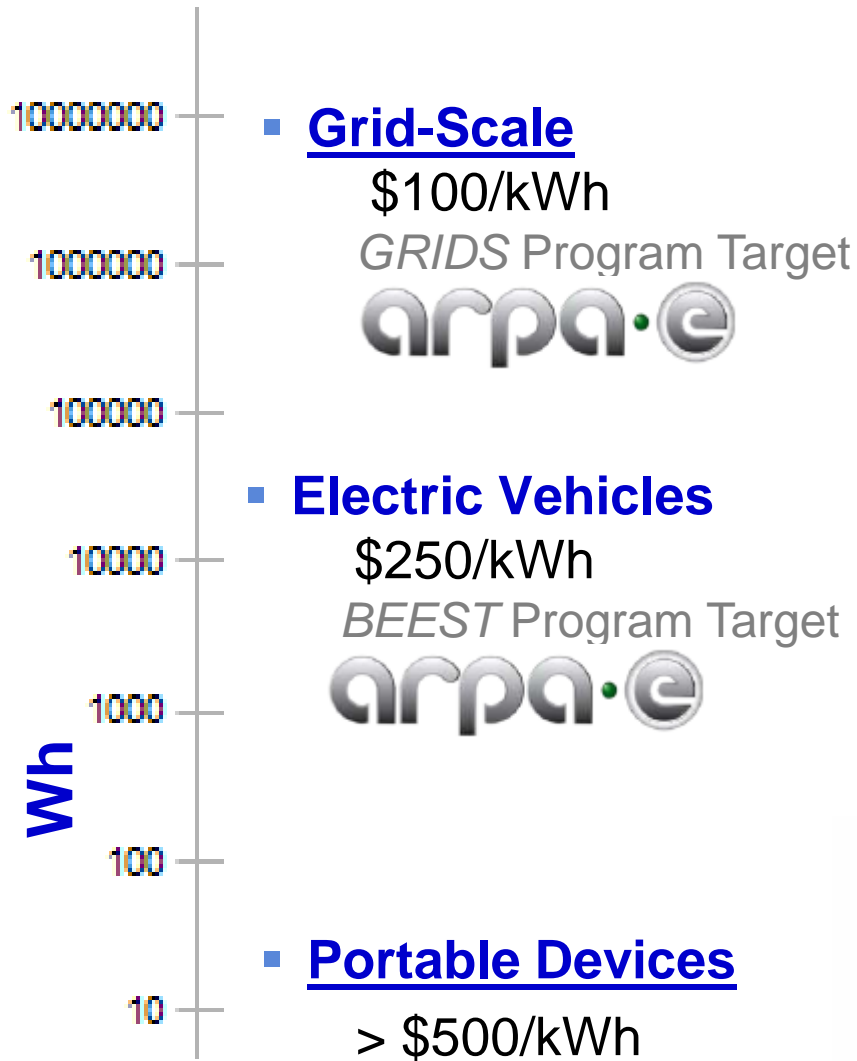

Batteries are currently < 1% of Grid-Scale EES

There is a (growing) need; but not being met by batteries

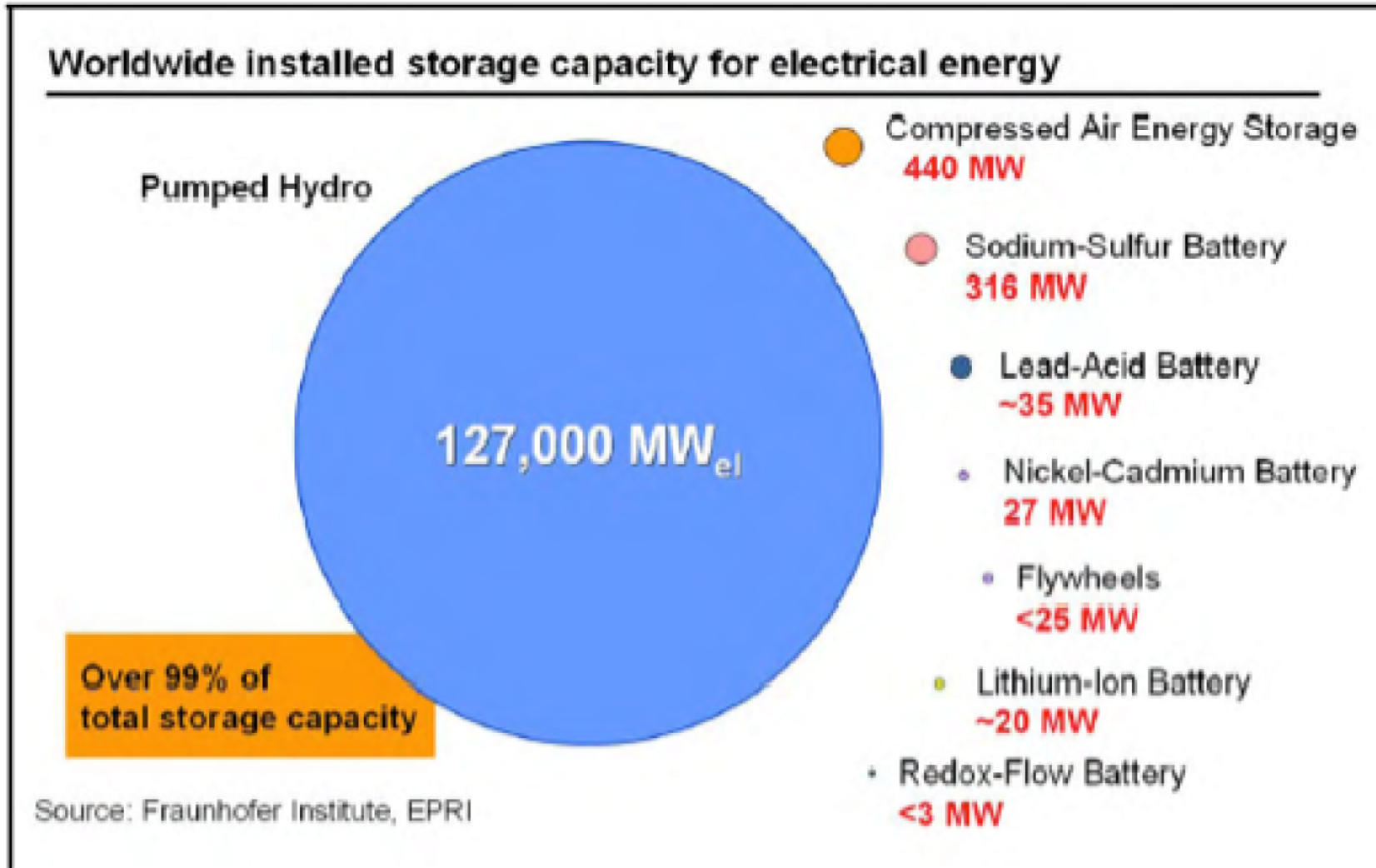

Key Issues with Conventional Batteries

These issues make conventional batteries ill-suited for large-scale EES

- Fundamental issues:
 - Power and Energy are not independent
 - Limits modular flexibility
 - Relatively low active-material-to-inactive-material ratios
 - Typically ~ ½ cost, weight, & volume
 - Relatively short cycle life with deep charge/discharge cycles
 - Electrodes undergo physiochemical changes
 - Safety is inherently challenging
 - Reactants are cannot be easily isolated
 - High replacement costs
 - Must replace essentially entire system
 - Lower round-trip efficiency with less expensive chemistries

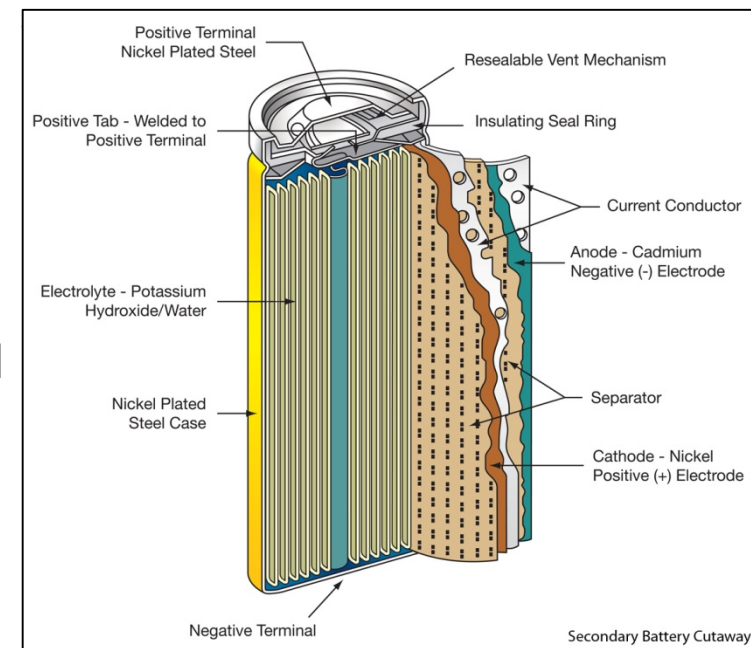
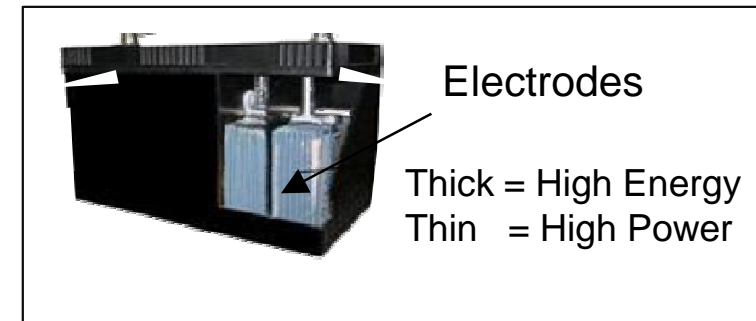

Flow Batteries are essentially rechargeable fuel-cell systems

Combine the best attributes of rechargeable batteries and fuel cells

Cell stack attributes

- Energy and power independent
- Long life cycle
- Low self-discharge rates
- Superior safety

Fuel cell issues (for energy storage)

- Low round-trip efficiencies
- Precious-metal catalysts
- Hydrogen storage

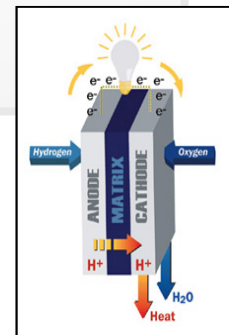

Flow Battery System

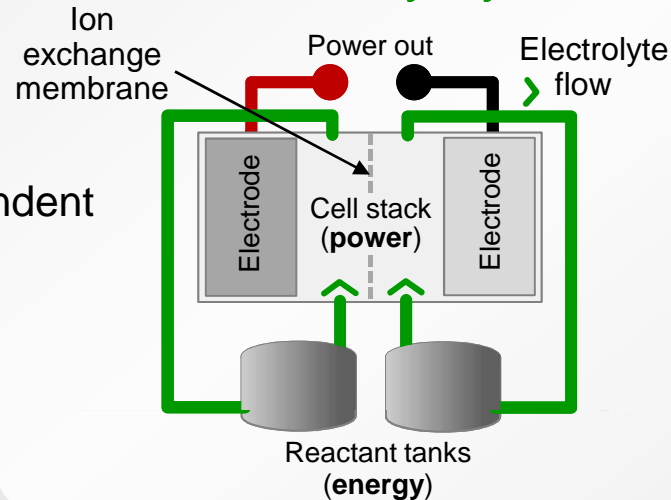

Battery attributes

- Rechargeable
- High round-trip efficiencies
- No precious-metal catalysts

Conventional battery constraints

- High power OR High energy
- Limited life cycle
- Continuous self-discharge



Battery System Architectures

Flow Batteries:

- Energy stored in solutions that are pumped or flowed through an electrochemical cell.
- Reactants contained outside of cell / stack.
- Charge-discharge via redox reactions in solution.
- Common redox couples: $V^{(+2/3)}-V^{(+4/5)}$, $Fe^{(+2/3)}-Cr^{(+2/3)}$

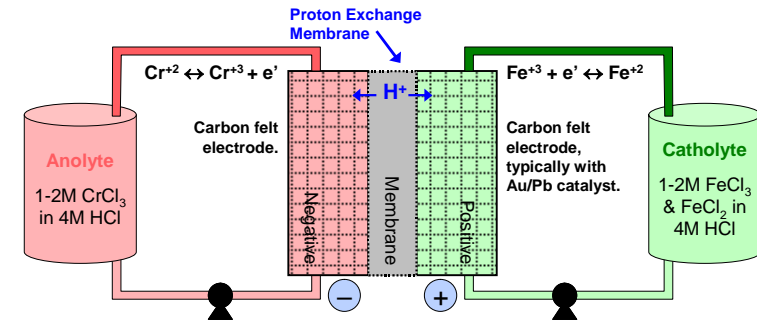

Hybrid Flow Batteries:

- One half cell involves solid-phase deposition
- Second half cell relies on flowing solution.
- Most common solid: $Zn(s) \rightarrow Zn^{+2}(aq) + 2e'$

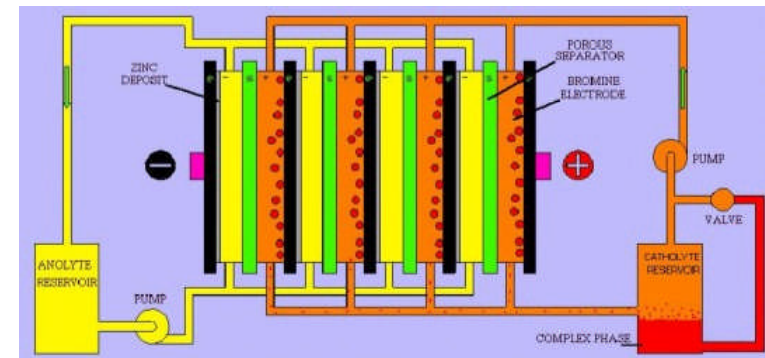

Conventional Batteries:

- All reactants stored with/inside the electrochemical cell
- May involve a combination of solid and liquid reactants
- May require thermal-management system (large packs)

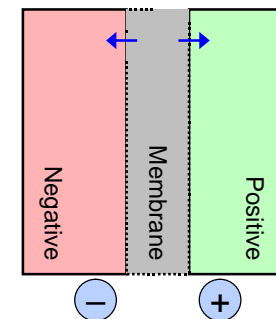

Flow Battery Systems (FBS) have been demonstrated in field

Technology is proven, but not cost effective

- Flow Battery concept originally developed by NASA in 1970s (Fe-Cr system)
- Multiple fielded FBS demonstrations have been done, especially with VRB (e.g., Sumitomo Electric in Japan)
- Generally, successful except for Capital Cost of the System

■ Example of fielded prototype unit

- Installed by VRB Power Systems
- 500-kW / 2-MWh plant in Moab, Utah
 - Ambient temperature range of -25 to 55+ C
 - T&D upgrade deferral in sensitive site
- Hand-off in Mar. 2004; run unmanned thru 2009
 - Availability > 96% over 5-yr period
 - Experienced PCS card failure (lightening strike)
 - Completed > 1600 cycles

However, technology has not received much attention in last ~ 30 years, since FBS is only suitable for large-scale EES applications, and the cost targets for these applications are very challenging (i.e., lower than portable or even transportation)



Battery Architecture Comparison

Preferred architecture will depend on EES Application

- Small EES applications favor less System Complexity
- Portable and Transportation applications value Energy Density

Key Attribute	Conventional	Flow
Energy Density	+	-
System Complexity	+	-
Inherent Safety	-	+
Deep Cycle Life	-	+
Cell-to-cell Uniformity	-	+
Power / Energy Independence	-	+
Capital Cost* (\$/kWh)	Inactive materials scale with Energy (kWh)	Inactive materials scale with Power (kW)

* Active material cost depends on chemistry; however, **active-material utilization will depend on architecture** (e.g., DoD limits, accessibility)

Inactive Cell Material Cost (\$/kWh)

Order-of-magnitude comparison of two types of battery architectures

Depends on:

1. Cost of materials (\$/m²)

- Conventional Battery:
 - Current Collector, Electrodes, Separator
 - Typically on the order of ~ **\$100/m²**
- Flow Battery = Stack repeat parts:
 - Bipolar Plate, Electrodes, Membrane
 - Typically on the order of ~ **\$1,000/m²** (at low production volumes)

2. Cell Power Density (W/cm²)

- $P = I \times V$
- **Both are typically ~ 100 mW/cm²**

3. Active material per cell (h at rated power)

- Conventional Battery = Typically < 1 h
- Flow Battery = Theoretically unlimited

Manufactured Cost	2007 MEA ¹ (\$/m ²)	2008 MEA ¹ (\$/m ²)
<i>Material</i>	135.48	117.71
- Membrane	- 13.89	- 13.83
- Electrode	- 109.61	- 91.90
- GDL	- 11.98	- 11.98
<i>Capital Cost</i>	7.08	6.57
<i>Labor</i>	0.99	1.02
<i>Tooling & Equipment</i>	3.80	3.73
<i>Other²</i>	1.73	1.71
Total	149	131

TIAX study, DOE Merit Review (2009)
Automotive PEMFC power plants,
Assumes 500K units/yr, 80-kW/unit
40-GW/yr. (includes Pt & assembly)

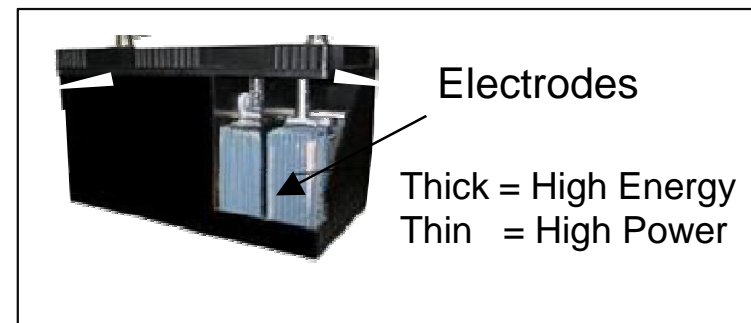

Inactive Material Cost (\$/kWh)

Current status is on the order of ~ \$250/kWh with both architectures

- No significant cost advantage based on architecture
- Both require significant improvements to meet ARPA-E targets

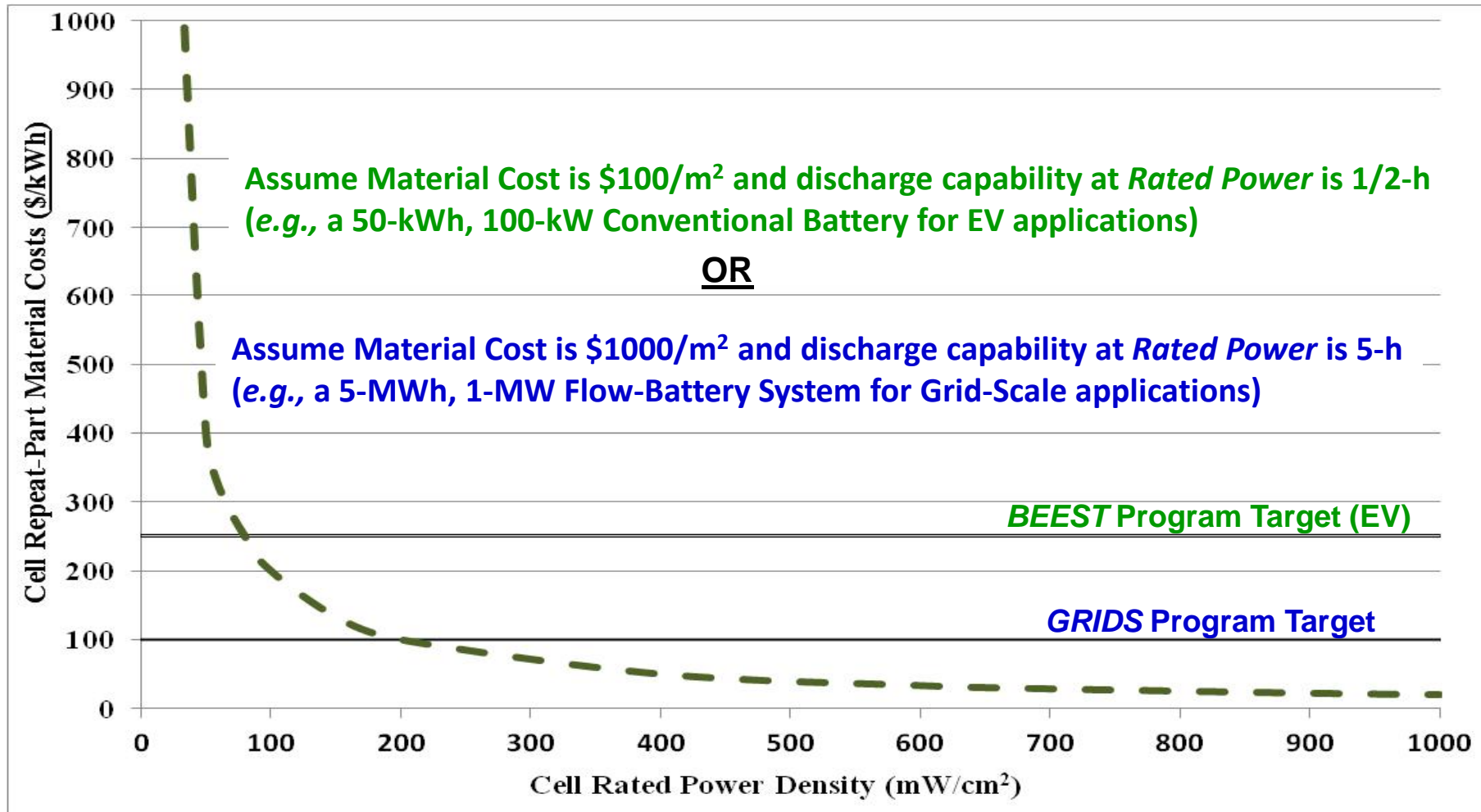

Flow-Battery cells are capable of high power densities

Already developed and demonstrated at UTRC with aqueous systems

- **UTRC has demonstrated > 10X improvement in power density**

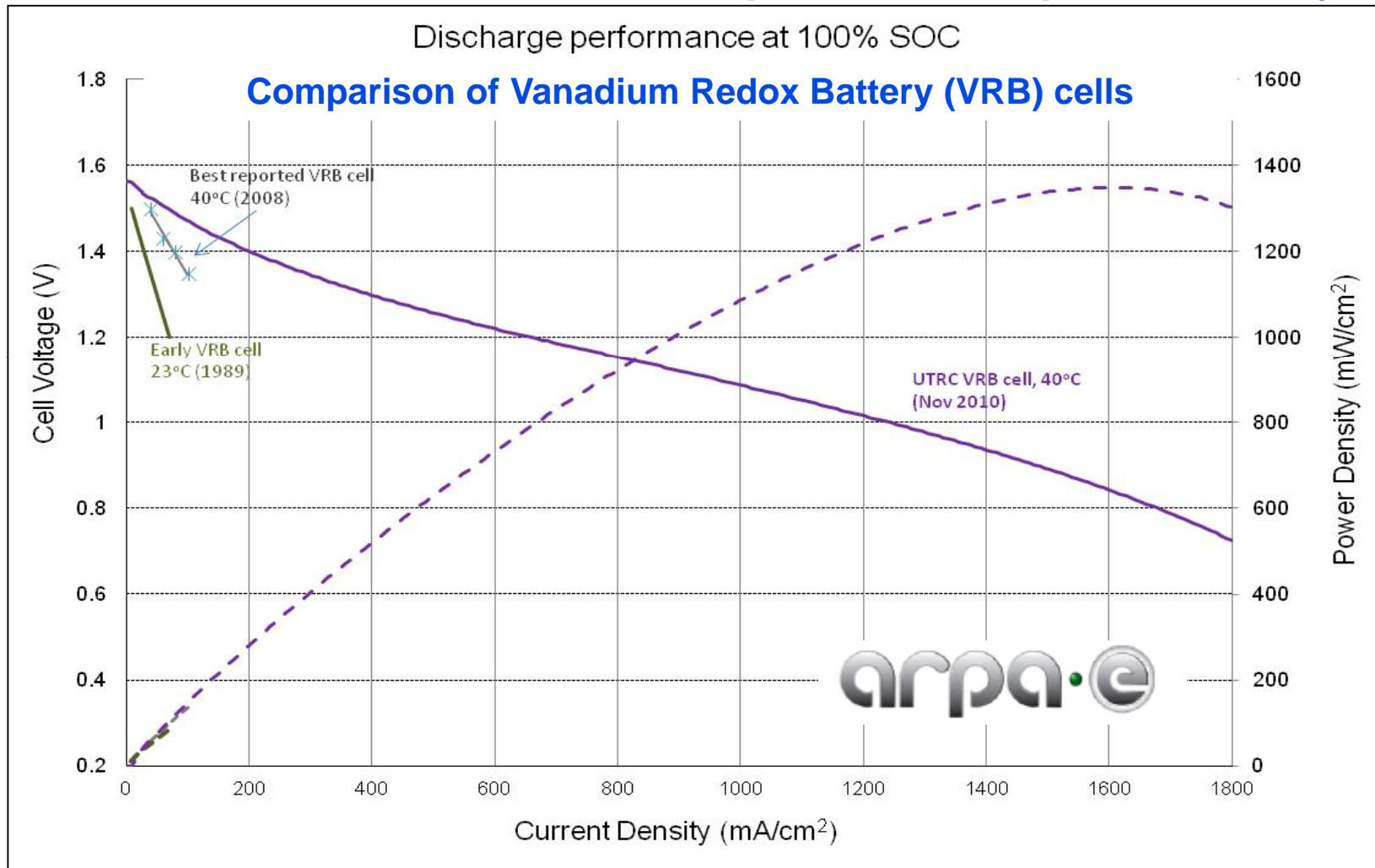

UTRC is currently scaling-up to complete Prototype System

- Key ARPA-e Project deliverable is 20-kW/40-kWh System demonstration Stack based on full-size cells ($> 800 \text{ cm}^2$ active area)



Improvements in Energy Density

Modified electrolytes can improve solubility of reactants

- Recent example from Pacific Northwest National Laboratory (PNNL)
 - Modified conventional Vanadium Redox Battery (VRB) chemistry
 - Instead of aqueous H_2SO_4 electrolyte, use mixture of HCl & H_2SO_4
 - Demonstrate > 60% improvements in Energy Density
 - Also improves temperature stability window (- 5 to 60 C)

Discharge Current, (mA.cm ⁻²)	Energy Density (Wh.L ⁻¹)			Columbic Efficiency			Energy Efficiency		
	Mixed		sulfate	Mixed		sulfate	Mixed		sulfate
	2.5MV	3MV	1.6MV	2.5MV	3MV	1.6MV	2.5MV	3MV	1.6MV
100	36.2	39.5	22.3	0.95	0.95	0.94	0.81	0.76	0.83
75	37.5	40.8	22.4	0.96	0.96	0.94	0.84	0.81	0.85
50	38.5	41.8	22.6	0.96	0.97	0.94	0.87	0.85	0.87
25	39.2	43.1	22.6	0.96	0.97	0.94	0.90	0.89	0.88

Cell operation conditions: 10 cm² flow cell, Charged to 1.7V by 50 mA/cm² current.

Also need domestic source of electrolyte solutions for VRBs

Non-Aqueous Flow Batteries

Growing interest in this area

- Wider potential-stability window
- Higher cell potentials enables:
 - Higher Energy Density solutions
 - If solubility is comparable to aqueous
 - Higher Power Density cells
 - If capable of comparable current densities
- Being investigated by multiple labs
- Two examples from last ECS meeting:
 - University of Michigan (U.M.)
 - Modified vanadium redox couples
 - Argonne National Lab (ANL)
 - Redox couples in Li-based electrolytes

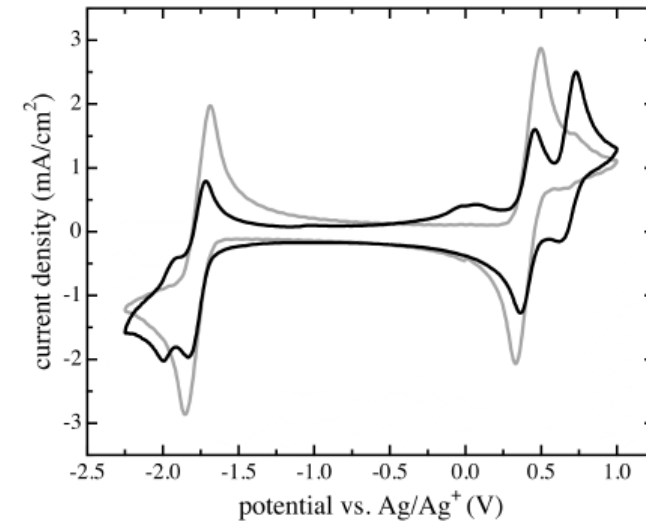

Figure 2. Comparison of cyclic voltammograms for fresh 0.01 M $V(acac)_3$ (gray line) and 0.01 M $V(acac)_3$ prepared from a sample that had been aged with trace amounts of air (black line).

From: **C.W. Monroe, et. al. (U.M.)**

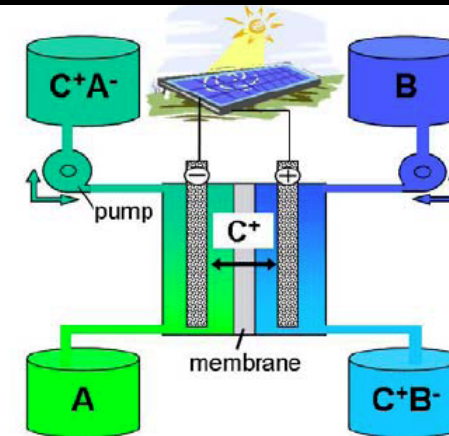

Figure 1. Simplified schematic of a non-aqueous flow battery for load-leveling and renewable energy storage. Species A and B represent generic electrode materials. Species C^+ represents a generic cation which shuttles across a membrane to maintain electroneutrality.

From: **F. Brushett, et. al. (ANL)**

Solid Materials in Flow-Battery Architectures

Not constrained by solubility limits

- Many possibilities...
 - Aqueous or non-aqueous electrolyte solutions
 - Reactants that are always solid or sometimes solid (e.g., Zn)
- Many challenges (and opportunities!)
 - Two-phase charge transfer
 - Solution stability and viscosity
- Example at this meeting:
 - MIT working on Li-ion and Carbon suspensions
 - Estimate 300 to 500 Wh/L possible
 - Work supported by BEEST program

Figures from: **W.C. Carter, Y.-M. Chiang, et al. (MIT)**

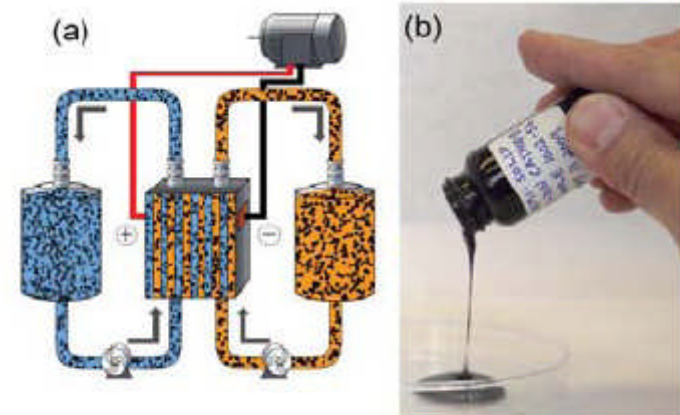

Figure 1a: Schematic of a semi-solid flow cell (SSFC) system using flowing lithium-ion cathode and anode suspensions.

Figure 1b: Semi-solid suspension containing LiCoO_2 powder and Ketjen Black dispersed in an alkyl carbonate electrolyte.

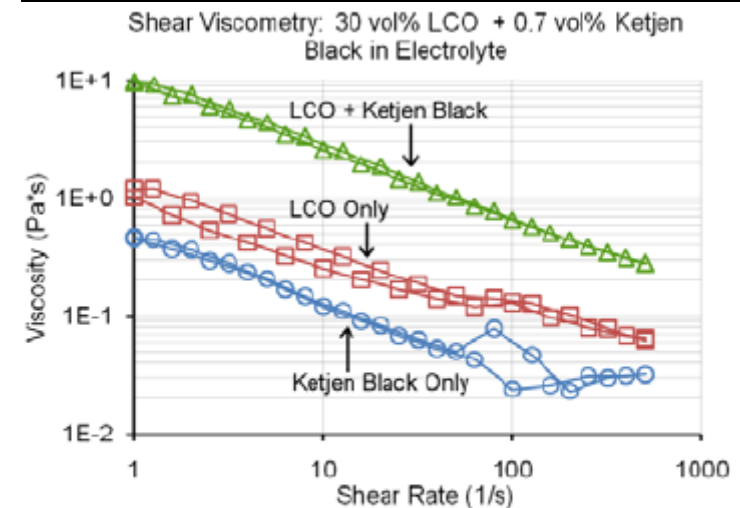
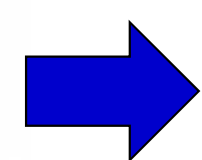
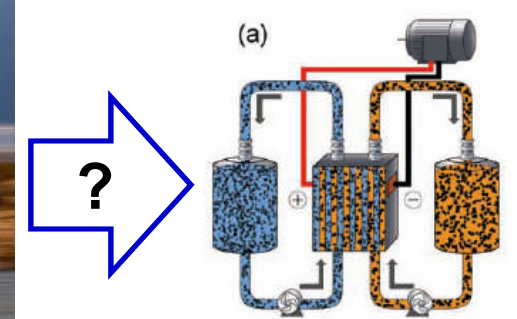
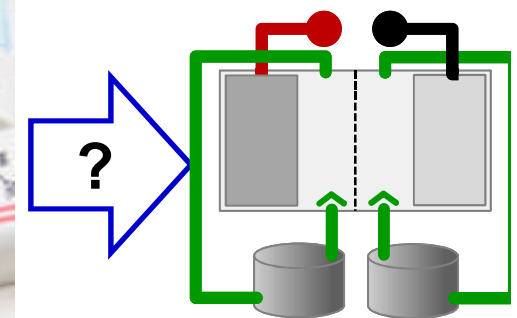
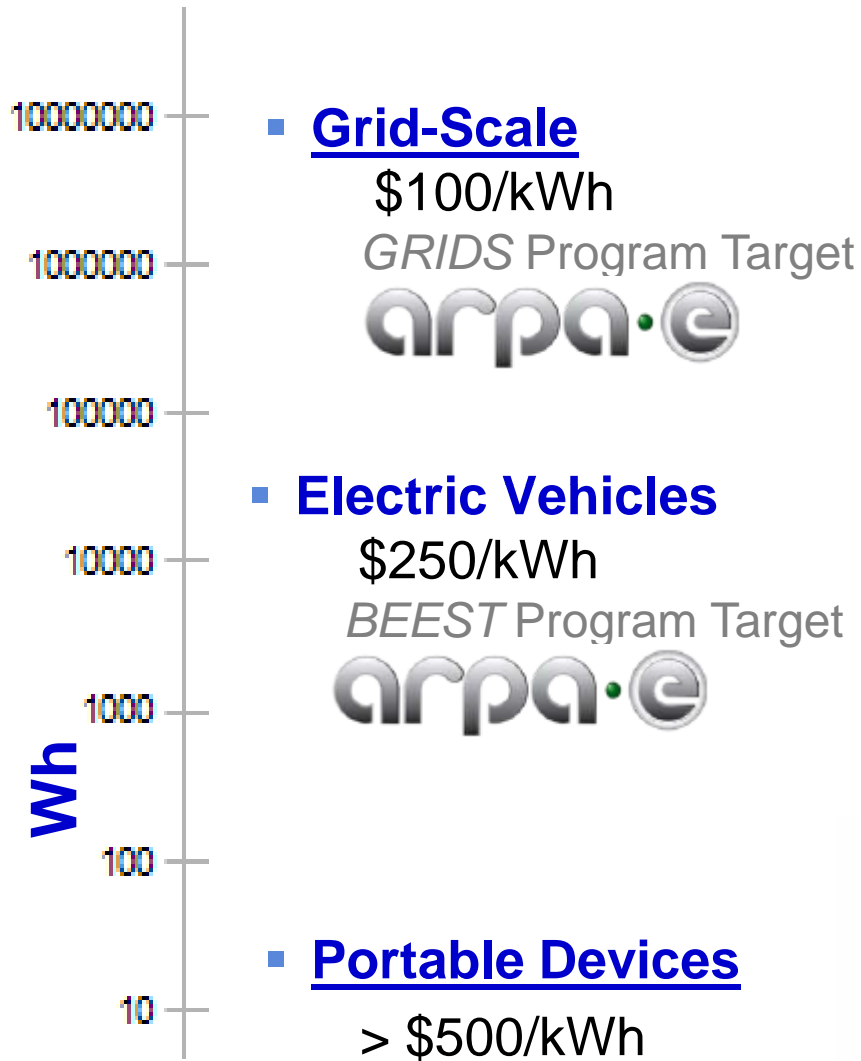

Figure 3: Flow curves of the components of a filled gel electrode, suspended in an alkyl carbonate electrolyte having a viscosity of 0.01 Pa*s.

Grand Challenges in Electrical Energy Storage (EES)

SCALE & COST: *Want to go from Wh to kWh to MWh...*



Future Flow-Cell Research Opportunities

Think “Outside the Box”... “Go with the Flow”

- Cell objective: *Improved performance with lower cost materials*
 - Reaction Kinetics
 - Fundamental mechanisms, pre-treatments, mitigation of side reactions
 - Two-phase charge transfer (for two-phase electrolyte solutions)
 - Advanced Cell Components
 - Electrodes (e.g., stability of surfaces under cyclic conditions)
 - Separators (e.g., are ion-exchange membranes required?)
 - Bipolar plates / Current collectors (e.g., alternatives to graphite?)
- Reactant objective: *Improved energy density and thermal stability window*
 - Advanced Reactant Materials
 - Modified redox couples (e.g., especially single-species pairs like VRB)
 - Supporting electrolytes (e.g., alkaline, or even neutral pH , options?)
 - Two-phase Dispersions
 - Rheological studies (e.g., improved stability, reduced viscosity)

Summary

Flow-Battery Architecture offer many advantages for large-scale EES apps

- Key Benefits:
 - Both High Energy Capacities and High Power Density cells
 - Minimize non-active material costs
 - Power & Energy are independent
 - High utilization of active materials
 - Inherently safer storage of reactants
 - Good round-trip energy efficiencies
 - Long cycle life
- Basic technology is proven, but not (yet) cost effective
- ***Future potential is promising***
 - Very limited development over the past three decades
 - Fuel-cell and battery developers well suited to transform these technologies

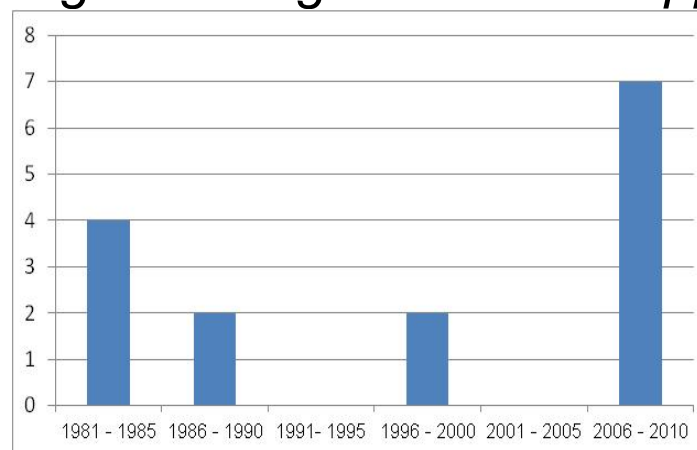

Number of papers appearing in peer-reviewed *JECs* and *Electrochemical & Solid-State Letters* that have the terms “flow battery,” “redox battery,” or “redox fuel cell” in the title or abstract

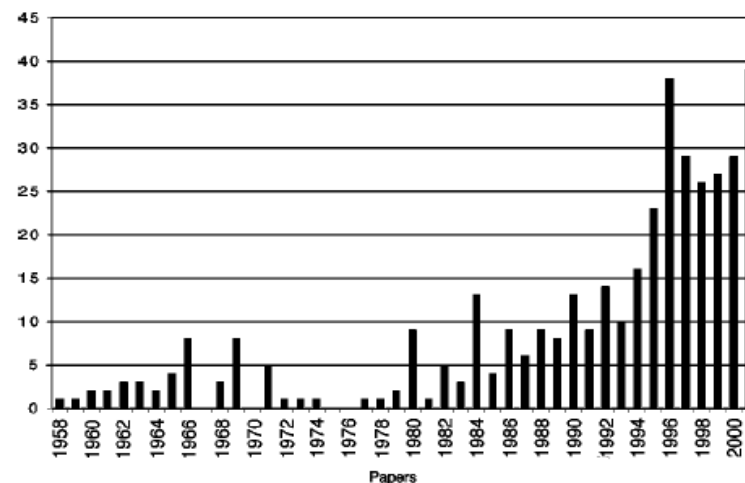

Figure 3. The number of papers appearing in the Journal which include the phrase “fuel cell” in the title.

M. Perry & T. Fuller, “A historical perspective of fuel-cell technology in the 20th Century,” *Journal of the Electrochemical Society*, **V149**, S59 (2002).