

Method and Apparatus for Handling and Dry Quenching Coke



New Equipment Results in Increased Yield and Emissions Reductions

Coke is a vital component of the iron and steel production process. Coke is derived by heating coal inside coking ovens. Once the coal to coke conversion is complete inside of the coking ovens, a ram pushes the hot coke from the oven into an open quenching car. The quenching car of hot coke is moved by rail to the quench tower, where several thousand gallons of water are used to cool the coke. The push and quench process at coke oven facilities is a very large source of fugitive dust, volatile organic compound (VOC), and wastewater emissions.

The Kress Indirect Dry Cooling (KIDC) System, demonstrated using a grant from the Department of Energy's Inventions and Innovation Program, replaces the quenching car with a sealable coke box. A carrier positions the box flush against the coke oven where the box can receive the push. During the push, the box is sealed at the jamb, and when the push is completed, the KIDC's guillotine door closes and the box is automatically sealed. Following the push, the carrier moves the box to the quench station and onto a cooling rack. Cooling water runs over the box to cool the coke indirectly. The KIDC system includes a vehicle, a series of boxes (a single box will serve approximately six ovens), a cooling rack with space for each box, and a receiving station. The entire cycle is planned with minimal operator involvement required, thereby eliminating human error. A computer with manual override controls all functions and moves if required.

Overview

- ◆ Developed by the Kress Corporation
- ◆ Demonstrated at 2 United States coke plants

Applications

Replaces the conventional push and quench process at steel mill coke-oven facilities

Capabilities

- ◆ Fugitive dust is nearly eliminated from the push and quench operations.
- ◆ VOCs emitted from the coke are controlled by a flare at the rear of the box.

Benefits

Energy Savings

Reduces energy requirements for emissions control and waste treatment equipment.

Environmental Benefits

Reduces emissions of particulates from the pushing operations by 75% while quenching emissions are virtually eliminated. There is minimal water quality impact, as the quenching water does not come in contact with the coke.

Productivity

Improves coke yield and quality because the coke is cooled slowly, does not become wet, and is not shocked by direct water quenching.

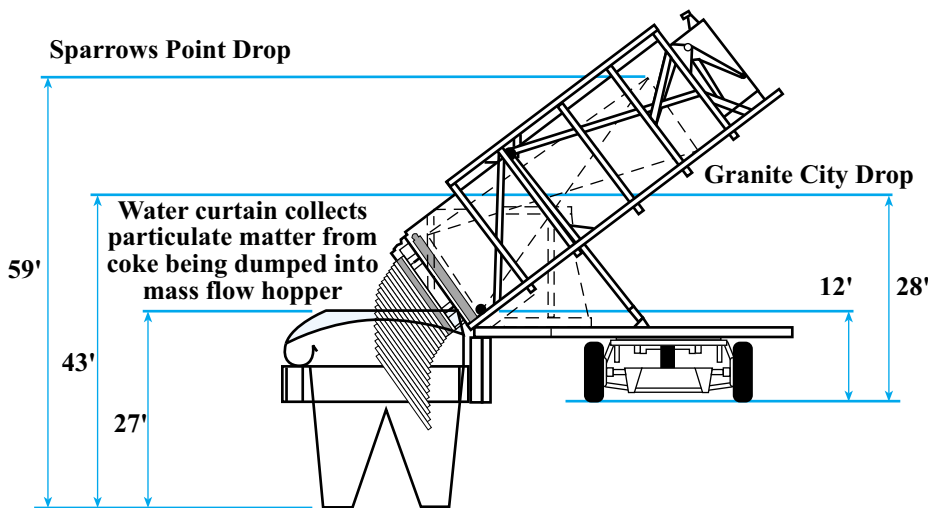

KIDC Carrier and Box Dumping Coke