

# METALCASTING

## Project Fact Sheet



## FILTERING MOLTEN METAL

### BENEFITS

- Energy savings of as much as 500,000 barrels of crude oil annually by reducing the scrap that must be remelted by an estimated 5%
- Makes stronger parts that can be lighter weight and can be transported with less energy use
- Lighter weight metal components in vehicles will require less fuel
- Uses off-the-shelf components
- Capital investment is small
- Creates savings from the reduced need to further machine products for a smooth surface finish
- Works with existing injection casting systems

### APPLICATIONS

This filtering method will work in the injection metal casting of many metals including iron, copper, zinc, and aluminum, as well as alloys. It is not designed for use in slab or continuous casting.

## FILTERING METAL INCREASES STRENGTH OF CASTINGS, REDUCES SCRAP

Casting molten metal presents many opportunities for contamination, often with particles as small as a few microns. This contamination may be slag, dross, or pieces of refractory from the melting crucible. Metal that contains impurities will have reduced strength, and this usually requires a heavier section thickness to compensate for the lower strength. Impurities also present serious stress points if they are located on the surface of the castings that are subjected to mechanical forces.

The standard ceramic cellular or reticulated foam filters are not readily adaptable to the highly automated die casting and permanent mold casting operations. This invention circumvents these problems by creating a filter system that has a continuous supply of filter material. Before each pour of metal into the shot tube or mold, the filter material is advanced to present a clean filter area. As the next section of clean filter material is advanced, the impurities that were filtered out can be observed on the exiting used filter.

### FILTERING MOLTEN METAL

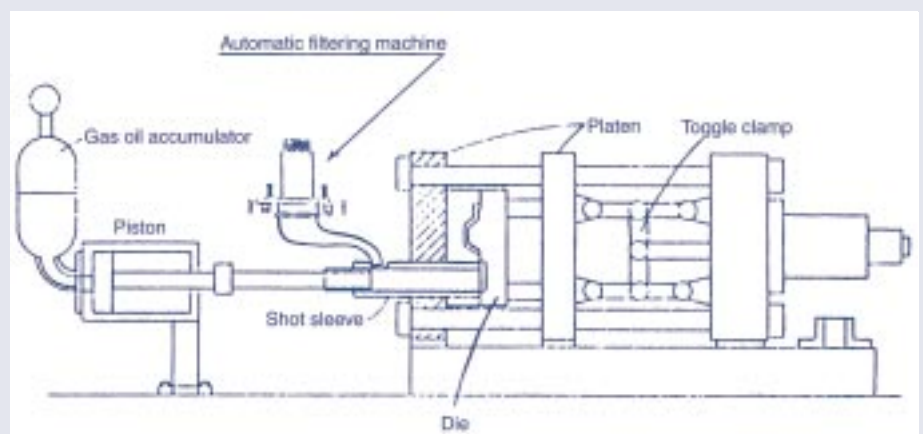

This schematic shows where an automatic filtering system would be installed where molten metal enters the die of one of the most common die casters. These types of die casters are used to produce many aluminum and zinc castings such as automobile parts and tools.



## Project Description

**Goal:** The goal of the project is to perform additional laboratory work to finalize the system design, optimizing the type of filter material best suited for the application, validating the estimated results, and inspiring commercial interest and acceptance. The resulting prototype will then be tested under actual foundry conditions.

A woven filter cloth made of metal wire, glass or ceramic fiber is automatically advanced between each pour, clamped, and sealed in place to filter the metal entering the mold.

Palmer Manufacturing and Supply, Inc. is developing this new technology with the help of a grant funded by the Inventions and Innovation Program through the Department of Energy's Office of Industrial Technologies.

## Progress and Milestones

- The technology has been well defined and tested at the laboratory level.
- The technology has been demonstrated in a video.
- Several foundries are interested in testing the prototype.
- Two U.S. patents have been awarded.

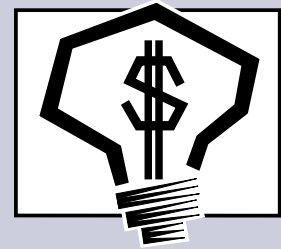

The Inventions and Innovation Program works with inventors of energy-related technologies to establish technical performance and conduct early development. Ideas that have significant energy savings impact and market potential are chosen for financial assistance through a competitive solicitation process. Technical guidance and commercialization support are also extended to successful applicants.

## PROJECT PARTNERS

Inventions and Innovation Program  
Washington, DC

Palmer Mfg. and Supply, Inc.  
Springfield, OH 45504

## FOR PROJECT INFORMATION, CONTACT:

Mr. Jack Palmer or Mr. Will Tinker  
Palmer Mfg. And Supply, Inc.  
25 Bechtle Ave.  
Springfield, OH 45504  
Phone: (800) 457-5456  
Fax: (937) 323-2709

## FOR PROGRAM INFORMATION, CONTACT:

Sandy Glatt  
Program Manager  
Inventions & Innovation Program  
U.S. Department of Energy  
1000 Independence Ave., SW  
Washington, DC 20585  
Phone: (202) 586-2079  
Fax: (202) 586-7114  
sandy.glatt@ee.doe.gov

Visit our home page at  
[www.oit.doe.gov](http://www.oit.doe.gov)

Office of Industrial Technologies  
Energy Efficiency  
and Renewable Energy  
U.S. Department of Energy  
Washington, D.C. 20585

## INDUSTRY OF THE FUTURE—METAL CASTING

*The metal casting industry – represented by the American Foundrymen's Society (AFS), North American Die Casting Association (NADCA), and the Steel Founder's Society of America (SFSA), has prepared a document, "Beyond 2000," to define the industry's vision for the year 2020. OIT's Metal Casting Vision Team partners with metalcasters, national laboratories, universities, and trade/environmental/technical organizations to develop and implement energy efficiency technologies that benefit both the industry and the United States. Recently, the Metal Casting Team facilitated the development of the Metal Casting Technology Roadmap, which outlines industry's near-, mid-, and long-term R&D goals.*

OIT Metal Casting Industry Team Leader: Harvey Wong (202) 586-9235.



DOE/GO-10099-681  
January 1999