



Improving efficiency of a vehicle HVAC system with comfort modeling, zonal design, and thermoelectric devices

Authors:

C.W. Maranville, Ford Motor Company

J. Schneider, Visteon Corporation

L. Chaney, National Renewable Energy Laboratory

T. Barnhart, GenTherm Incorporated

J.P. Heremans, The Ohio State University

DOE Technology Manager: **John Fairbanks**

NETL Project Manager: **Carl Maronde**

CEC Project Manager: **Rhetta deMesa**

DEER Conference

Detroit, MI

October 18, 2012

Disclaimer



This report was prepared as an account of work sponsored by the California Energy Commission and pursuant to an agreement with the United States Department of Energy (DOE). Neither the DOE, nor the California Energy Commission, nor any of their employees, contractors, or subcontractors, makes any warranty, express or implied, or assumes any legal liability or responsibility for the accuracy, completeness, or usefulness of any information, apparatus, product, or process disclosed, or represents that its use would not infringe privately owned rights. Reference herein to any specific commercial product, process, or service by trade name, trademark, manufacturer, or otherwise, does not necessarily constitute or imply its endorsement, recommendation, or favoring by the DOE, or the California Energy Commission. The views and opinions of authors expressed herein do not necessarily state or reflect those of the DOE or the California Energy Commission, or any of their employees, or any agency thereof, or the State of California. This report has not been approved or disapproved by the California Energy Commission, nor has the California Energy Commission passed upon the accuracy or adequacy of the information in this report.

Project Relevance / Objectives



Project Goal: Identify and demonstrate technical and commercial approaches necessary to accelerate deployment of zonal TE HVAC systems in light-duty vehicles

Program Objectives:

- Develop a TE HVAC system to optimize occupant comfort and reduce fuel consumption
- Reduce energy required from AC compressor by 1/3
- TE devices achieve $COP_{cooling} > 1.3$ and $COP_{heating} > 2.3$
- Demonstrate the technical feasibility of a TE HVAC system for light-duty vehicles
- Develop a commercialization pathway for a TE HVAC system
- Integrate, test, and deliver a 5-passenger TE HVAC demonstration vehicle

FY2012 Objectives:

- Continue thermal comfort modeling toolset development
- Finalize design & build all components for prototype vehicle integration
- Complete TE device fabrication and bench testing
- Complete evaluation of advanced TE heating/cooling materials at module level
- Initiate ancillary loads trade-study
- Conduct initial system and component cost analysis

Technical Approach to HVAC Design

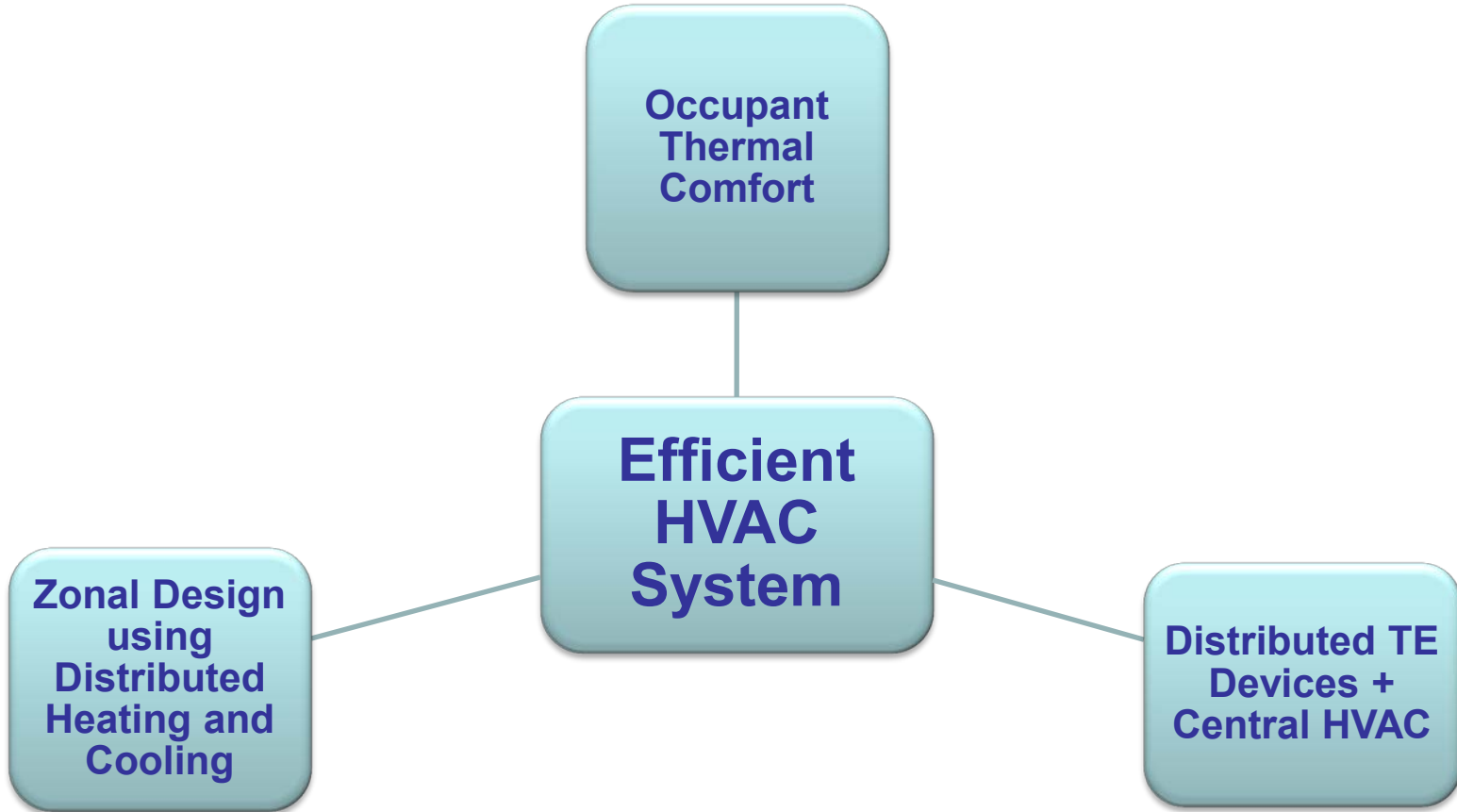

Phase 3 Task Overview (Jan '12 to Nov '12)



System-level HVAC architecture design

- Complete component packaging study
- Enhance multi-domain thermal comfort tools for design optimization
- Detailed design, build, and bench validation of components and subsystems:
 - Power supplies, air handling & distribution, liquid system, sensors & controls
- Initiate ancillary load reduction trade-off study
- Complete detailed system BOM and cost analysis

TE HVAC device development and materials research

- Utilize predictive computer models to optimize thermoelectric engines and matching heat exchangers
- Design and develop high performance mass producible liquid and air heat exchangers
- Continue to develop and optimize the manufacturing methods for fabricating thermoelectric engines
- Investigate routes to advanced thermoelectric materials with enhanced figure-of-merit

Success Criteria

- Vehicle-intent TE based subsystems meet bench-level performance and durability tests
- Cost analyses shows that there is a potential business case for a TE HVAC system

Phase 4 Workplan (Dec'12 to Aug'13)



System-level HVAC architecture design

- Integrate zonal climate system components, instrumentation, and sensors into vehicle
- Deploy basic control strategy for zonal, occupant-based HVAC system control
- Validate zonal system performance and compare to baseline tests
- Conduct jury testing to assess thermal comfort of zonal system
- Calculate HVAC energy utilization and compare to baseline tests

TE HVAC device development and materials research

- Study conducted to assess the design and manufacturing routes to low-cost, high-performance TE subassemblies
- Complete a vehicle-level commercialization assessment for zonal TE HVAC deployment

Success Criteria

- TE HVAC system meets thermal comfort performance criteria
- TE HVAC system demonstrates reduction in energy consumption compared to baseline
- Measured TE device COP meets program objectives
- Cost study and commercialization analysis show TE HVAC commercialization pathway

Vehicle Platform: 2011 Lincoln MKZ HEV



Occupant Thermal Comfort Analysis



Thermal manikin compared to trained climate control observer
Temperature, sensation, comfort



Thermal manikin helps to validate virtual manikin
Segment temperature, sensation, comfort

Design impacts performance
Design for comfort

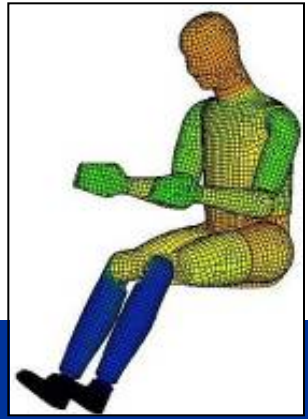
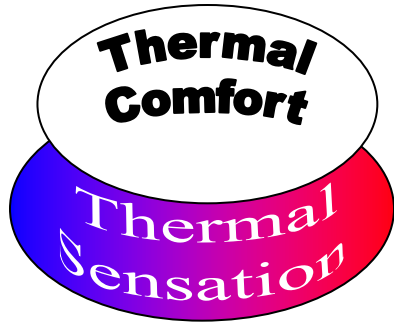

CAE tool guides design
Zonal climate control

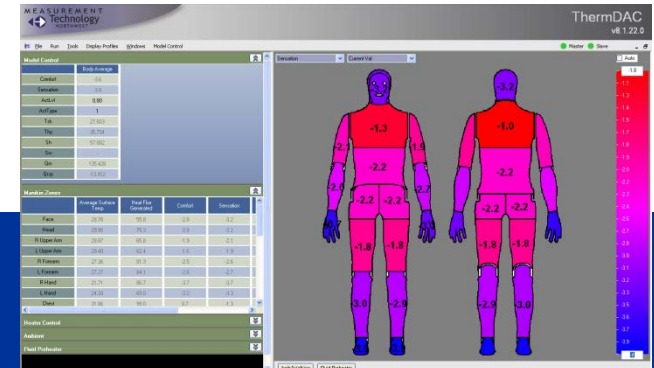

Comfort Validation Study



A/C Cool-Down Test: Thermal Sensation vs Time

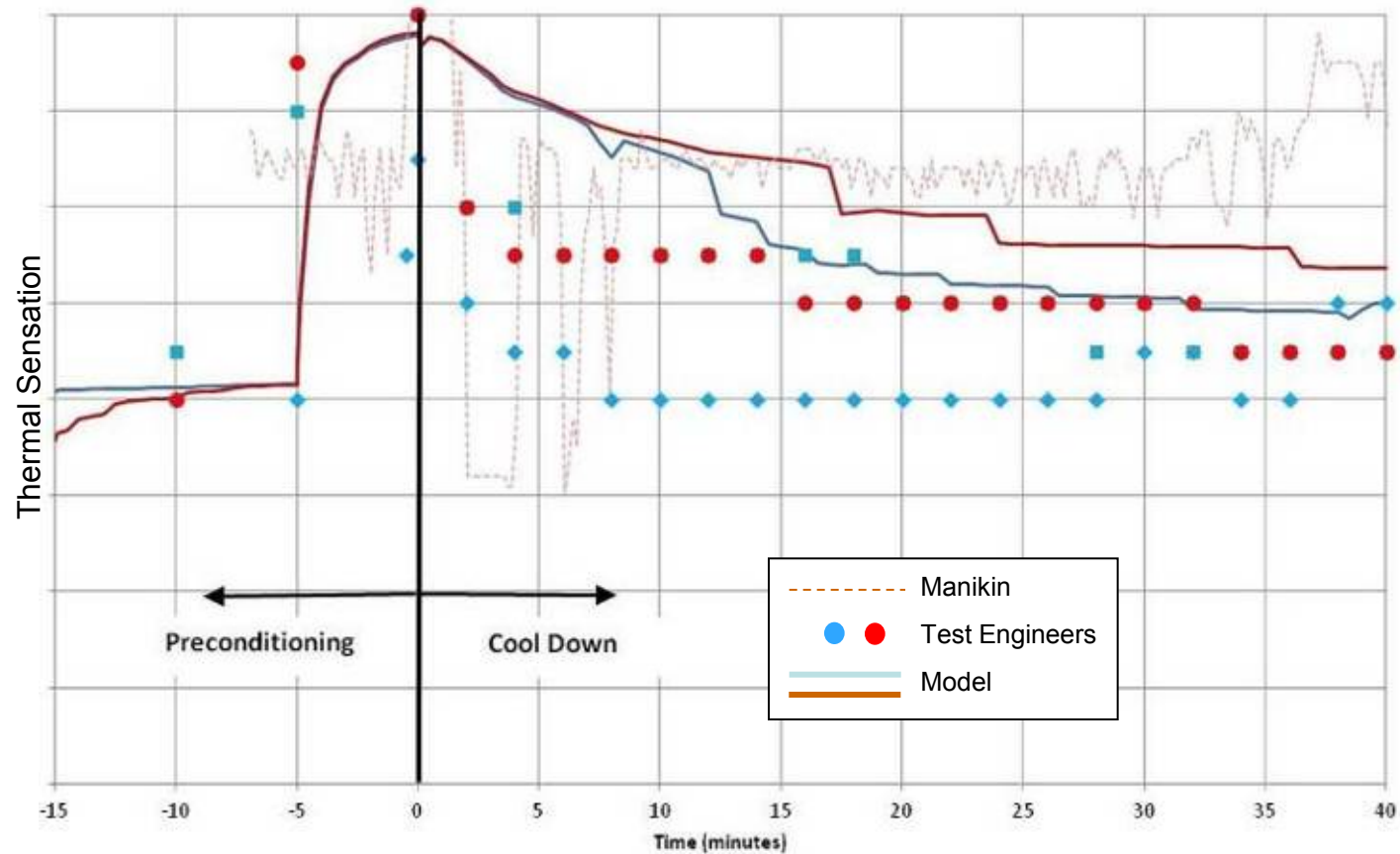

Good correlation between models, manikin, and test subjects

ZONAL THERMOELECTRIC DEVICE DEVELOPMENT



TE Device for Zonal System
LWH: 50x120x300mm



TE unit bench test

- Thermal cycling testing is ongoing for 2 units, currently at ~ 7000 cycles each with an average input power of $\sim 800W$
- Sealed units capable of managing condensation
- Transient model validation and correlation completed
- 6 Units for system testing and the vehicle build have been fabricated

TE DEVICE PERFORMANCE MODEL VS TEST

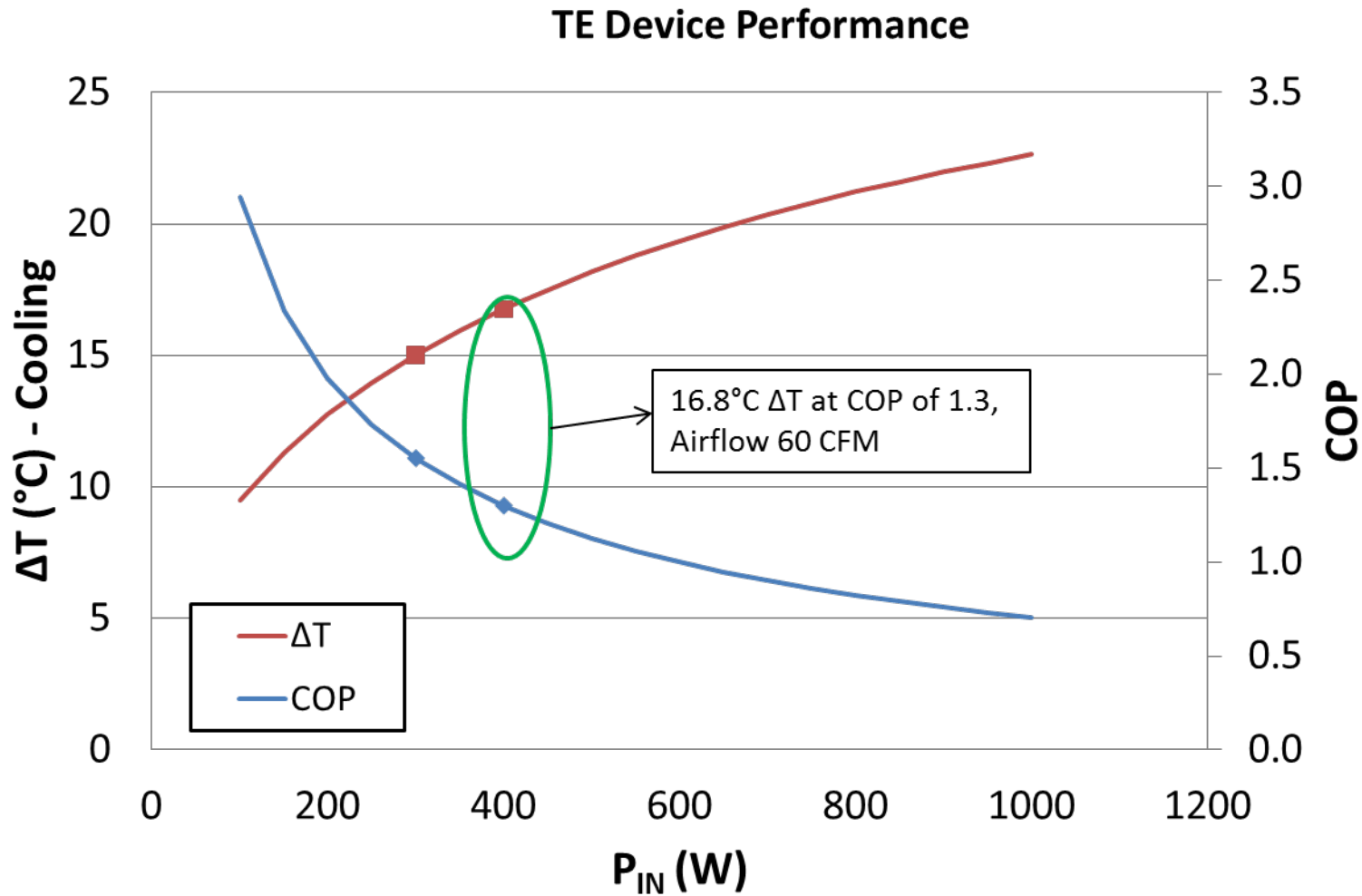

Zonal HVAC System Design



- Design verified using subjective and objection evaluations in thermal chamber tests
- HVAC design requirements developed to allow detailed component and sub-system design:
 1. Power Supplies for TE units, Blowers, and Liquid Pumps
 2. Liquid Loop
 3. Air Handling, Including Ducts & Blowers
- System and component fabrication completed
- Verification bench testing scheduled for 4Q2012

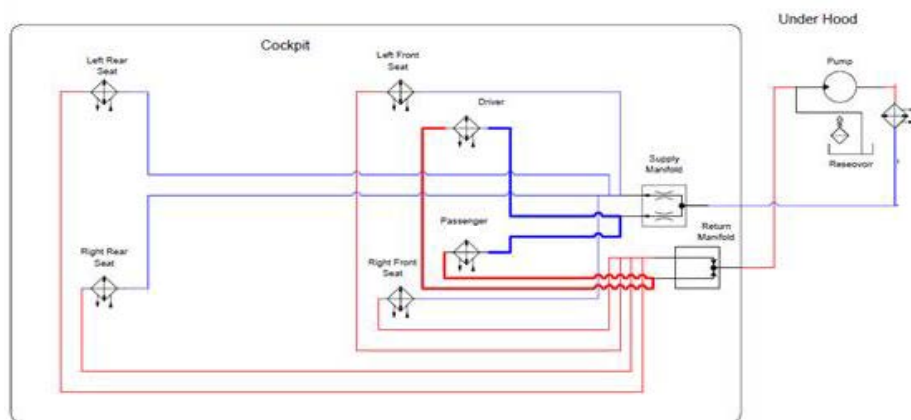

Liquid Loop Schematic

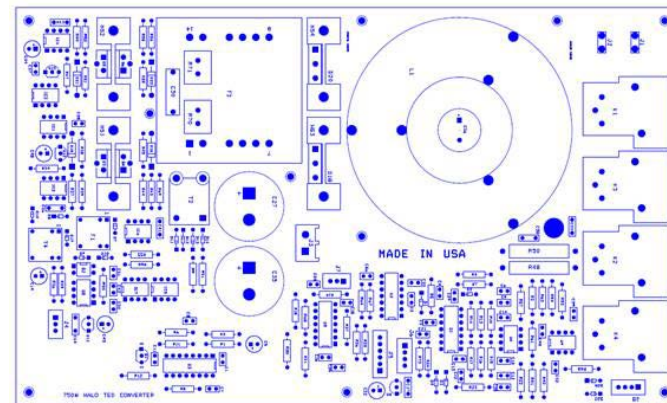

TE Power Supply PWB Design

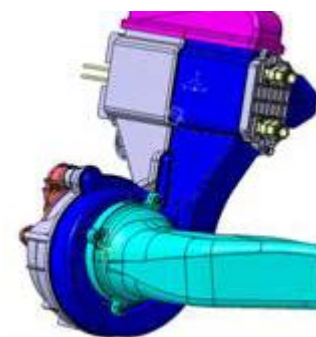

Blower & TE Housing Design

Zonal System Layout

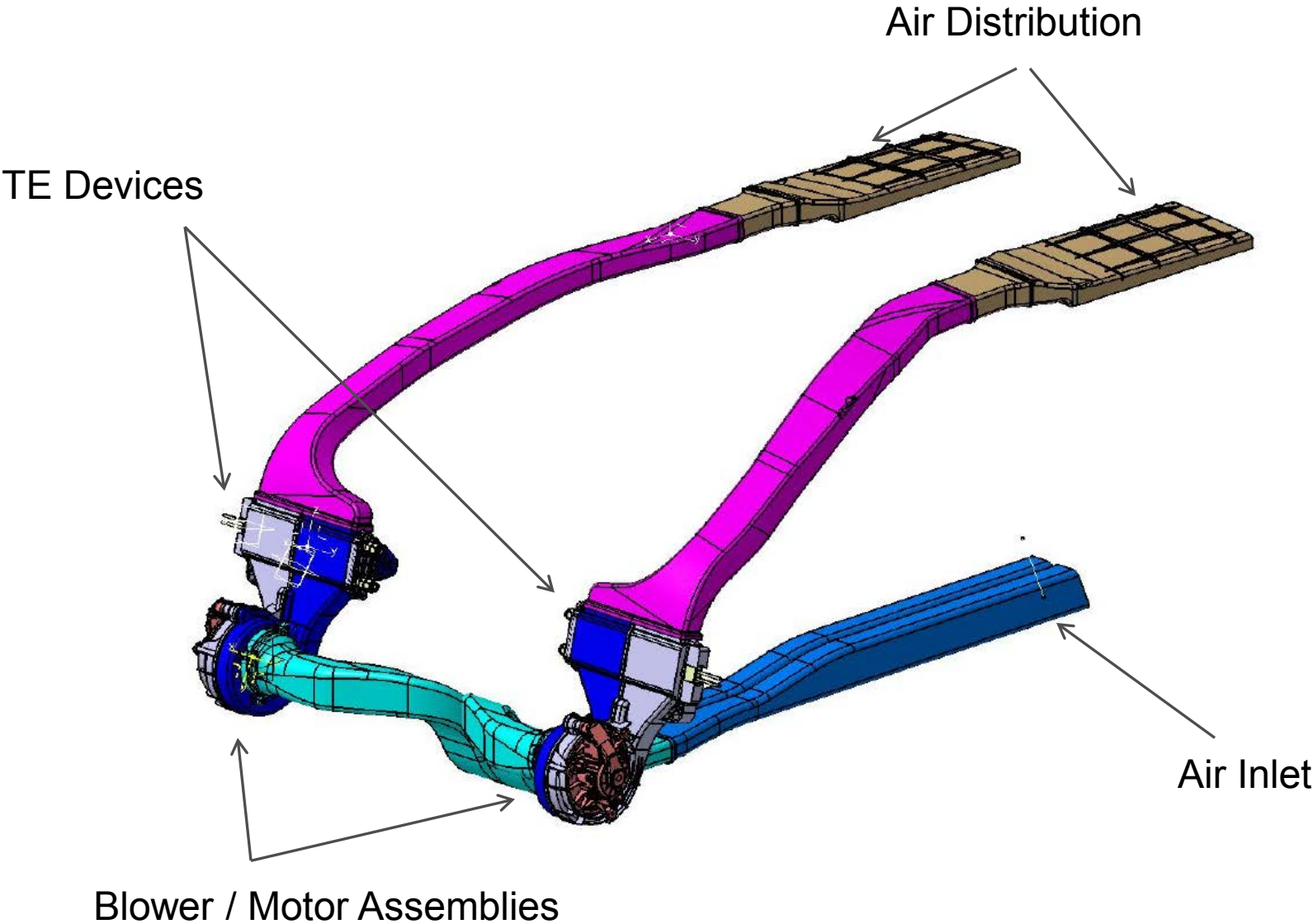

CLIMATE CONTROL SEAT DEVELOPMENT

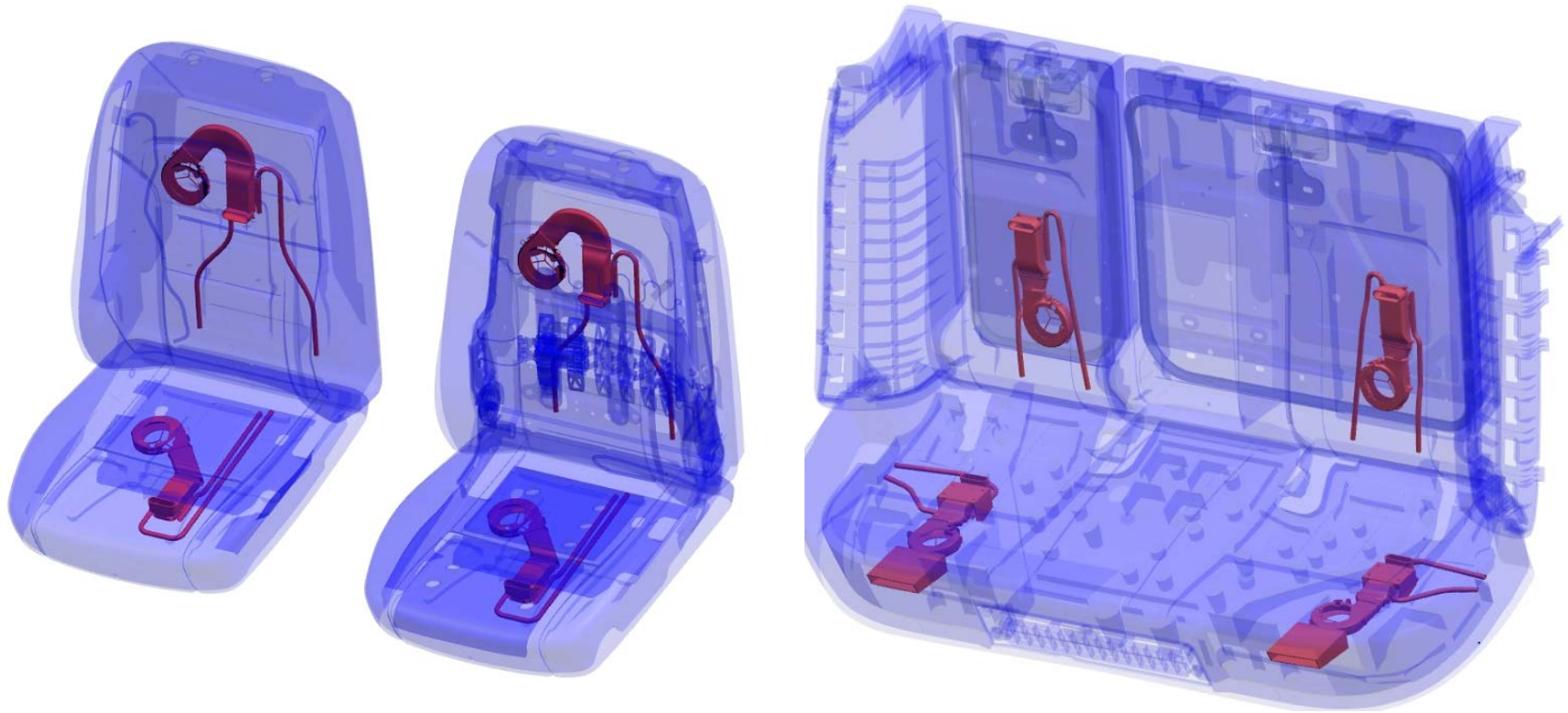

- Design of Liquid Loop CCS completed
- 8 liquid/air TE units in 4 seating positions
- Units capable of 10°C DT at 100 W_{elec}
- Utilize similar air distribution methodology as current CCS designs

Advanced Materials: Peltier couple tests

- Pass current (I) through assembled p - n Peltier couple
 - Measure $\Delta T(I)$, some I yields ΔT_{\max}
 - Direct measurement of device ZT
- zT_{device} tests on OSU material do not match up with 3 parameter zT
 - Attempting different contact technologies to verify performance of new materials

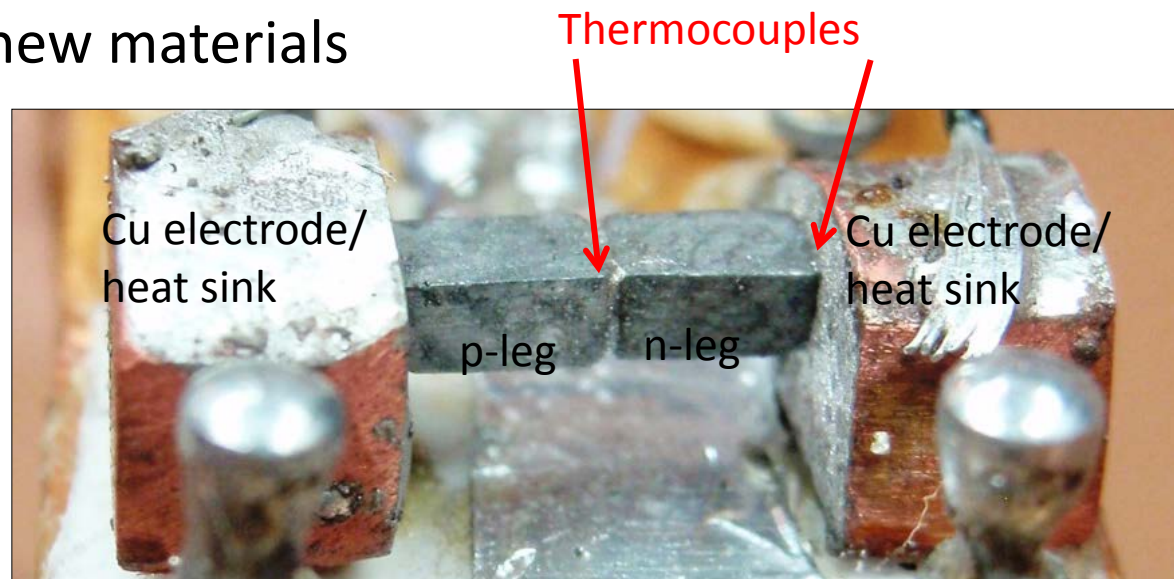
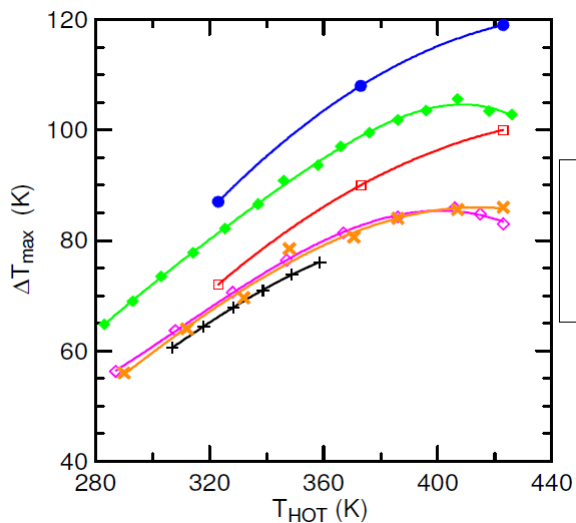

Summary and Future Work



- Project focuses on developing methods to optimize climate system efficiency while maintaining occupant comfort at current levels using new technology, architecture, and controls approaches
- Zonal TE HVAC commercial viability improves as vehicles evolve towards higher levels of electrification and engineering attribute criteria accounts for quantitative occupant-based comfort metrics
- Project on target to meet Phase 3 milestones and deliverables by the end of 4Q12:
 - Architecture selection, detailed design, fabrication, and bench validation testing
 - TE device performance and durability assessment
 - Cost analysis
- In-vehicle installation planned for 1Q13, system validation testing May – July 2013, project completion targeted for August 2013

Acknowledgements



- We gratefully acknowledge the US Department of Energy and the California Energy Commission for their funding support of this innovative program
- A special thank you to John Fairbanks (DOE-EERE), Reynaldo Gonzales (CEC), and Carl Maronde (NETL) for their leadership
- Thanks to the teams at Ford, Visteon, GenTherm, NREL, and OSU for their work on the program

U.S. DEPARTMENT OF
ENERGY

Energy Efficiency &
Renewable Energy

