

# 2010 DOE Vehicle Technologies Program Review

Presentation LM015, Mark T. Smith, (509) 375-4478,  
[mark.smith@pnl.gov](mailto:mark.smith@pnl.gov)

- 1. Pulse Pressure Forming of Lightweight Materials**
- 2. Development of High Strength Superplastic Aluminum Sheet for Automotive Applications**
- 3. Friction Stir Spot Welding of Advanced High Strength Steels**

This presentation does not contain proprietary, confidential, or otherwise restricted information

Project ID: LM015



**Pacific Northwest**  
NATIONAL LABORATORY

*Proudly Operated by Battelle Since 1965*

## 2010 DOE Vehicle Technologies Program Review

# Pulse Pressure Forming of Lightweight Materials

P.I.: Richard Davies, (509) 375-6474, [richard.davies@pnl.gov](mailto:richard.davies@pnl.gov)

Presenter: Mark T. Smith, (509) 375-4478, [mark.smith@pnl.gov](mailto:mark.smith@pnl.gov)

This presentation does not contain proprietary, confidential, or otherwise restricted information

Project ID: LM015



**Pacific Northwest**  
NATIONAL LABORATORY

*Proudly Operated by Battelle Since 1965*

# Project Overview

## Project Timeline:

- ▶ Start – 3Q FY08
- ▶ Finish – 3Q FY11
- ▶ 65% complete

## Budget:

- ▶ Total project funding:
  - PNNL: \$1475k
- ▶ FY08 Funding Received:
  - \$200k
- ▶ FY09 Funding Received:
  - \$450k
- ▶ FY10 Funding Received:
  - \$450k
- ▶ FY11 Funding Request:
  - \$375k

## Targets

- ▶ The VTP target for weight reduction of the vehicle and its subsystems is 50%.
  - Pulse Pressure Forming (PPF) of aluminum and Advanced High Strength Steels (AHSS) has the potential to achieve 25 to 45% weight savings vs. conventional steels

## Barriers

- ▶ Barriers to using PPF of aluminum and AHSS in the lightweighting of vehicles:
  - Lack of understanding of the formability and strain rates that develop during PPF processing
  - Lack of validated constitutive relations for lightweight materials during PPF processing
  - Lack of validation of finite element simulation of PPF processing

## Partners

- ▶ OEM and Industry participants:
  - Sergey Golovashchenko (Ford)
  - John Bradley (General Motors)
  - Ajit Desai, Chrysler
  - US Steel, Alcoa

# Relevance to Technology Gaps:

## Project Objectives:

- ▶ Enable broader deployment of automotive lightweighting materials in body-in-white and closure panels through extended formability of aluminum alloys, magnesium alloys, and HSS/AHSS.
- ▶ Enable a broad set of PPF technologies to effectively extend the benefits of high rate sheet metal forming beyond the limitations of electrically conductive metals (aluminum) that are required for electromagnetic forming (EMF) processes.
- ▶ Aluminum and AHSS have limited formability at room temperature and conventional strain rates. High strain rate forming (PPF) can enhance room temperature formability
  - Extended ductility of most metals
  - Extend the formability of AHSS at high rate loading
  - Generate greater ductility from lower cost steels
  - Increase formability of Al and Mg alloys
  - Utilize single-sided tooling at lower cost
  - Provide residual stress (springback) management
- ▶ PPF of Lightweight Materials will address technology gaps
  - Demonstrate and quantify extended ductility in Al, AHSS and Mg using PPF process and high speed camera system
  - Validate high strain rate constitutive relations for PPF of lightweight materials
  - Characterize material microstructure and texture evolution at high strain rates



**Pacific Northwest**  
NATIONAL LABORATORY

*Proudly Operated by Battelle Since 1965*

# Approach/Strategy

## Task 1 Formability and Fracture Characterization

- Design, fabricate, and demonstrate the operation of the PPF system. This includes procuring high-speed cameras for real-time image capture for strain-time history using existing PNNL DIC system
- Perform sheet forming experiments using single pulse and multi-pulse PPF of Al-5182, DP600, and Mg-AZ31 sheet materials
- Characterize high rate formability and extended ductility

## Task 2 Microstructure and Mechanical Property Evolution

- Develop materials constitutive relations for high rate forming
- Characterize microstructural and texture evolution
- Characterize post-forming mechanical properties

## Task 3 Numerical Simulation of PPF Process

- PPF sheet forming finite element modeling
- Sheet-die interaction during PPF



**Pacific Northwest**  
NATIONAL LABORATORY

*Proudly Operated by Battelle Since 1965*

# Project Milestones

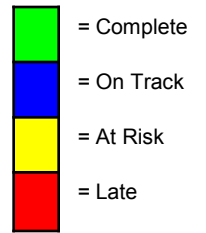

Milestones	Due	Color	Issues?
Demonstrate successful operation of the PPF apparatus	11/08		
Complete experimental characterization of PPF process	9/11		
Complete constitutive relations for Al, Mg, and AHSS	3/10		
Complete evaluation of post-forming properties of materials subject to PPF	6/11		
Complete evaluations of numerical simulations	3/11		



# Background and Technical Accomplishments

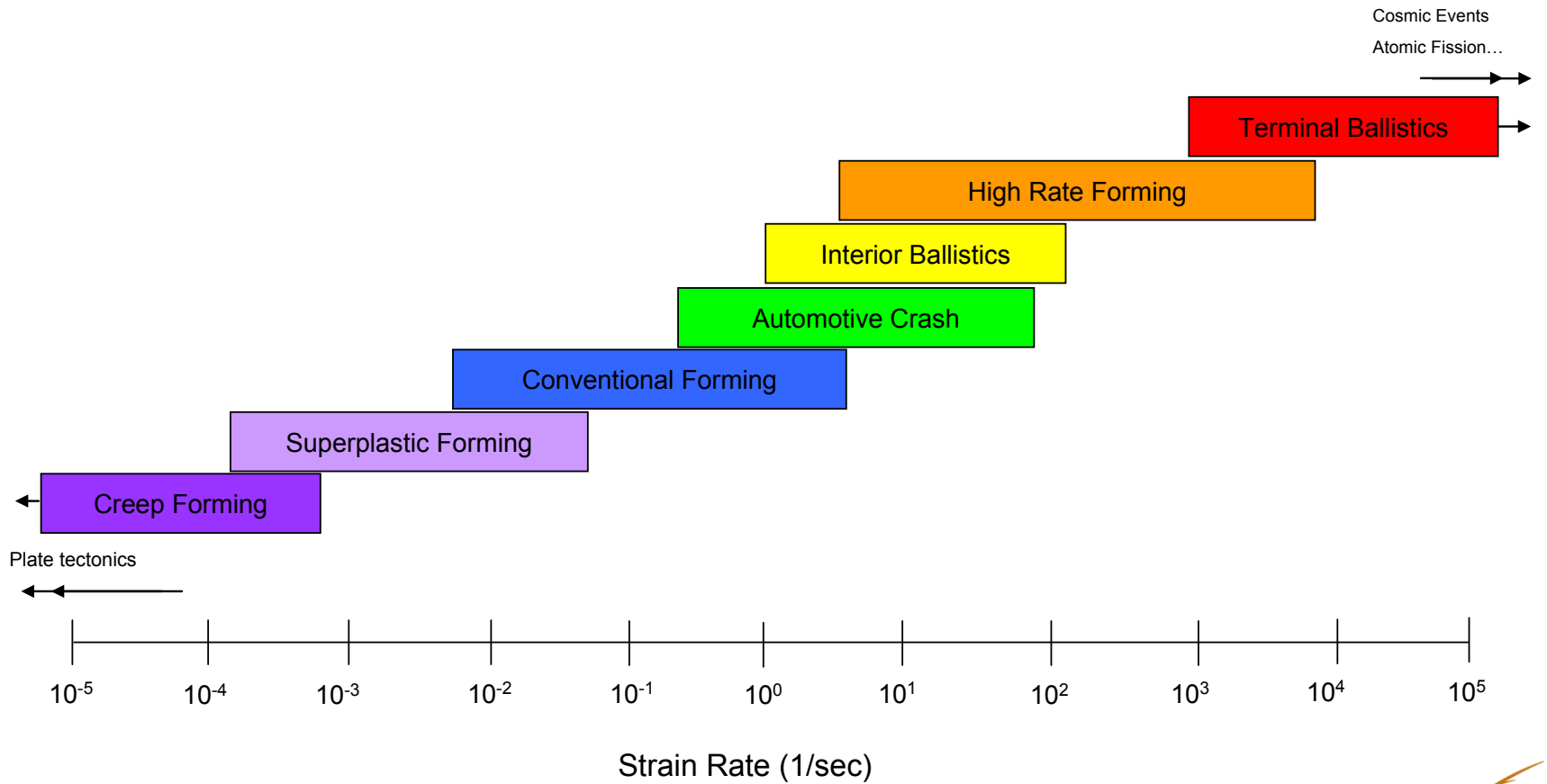

# Introduction

## High Rate Forming Technologies

- ▶ Electromagnetic Forming (EMF)
- ▶ Electrohydraulic Forming (EHF)
- ▶ Explosive Forming (classical)
- ▶ Laser Shock Forming (LSF)

## Project Plan - Subject Materials

- ▶ Aluminum Alloys
  - Initial focus on AA5182-O (1 mm and 2 mm)
- ▶ AHSS (and HSS)
  - Initial focus on DP600 (1 mm and 0.6 mm)\*
- ▶ Magnesium Alloys
  - Initial focus on AZ-31

\*Materials provide by US Steel



**Pacific Northwest**  
NATIONAL LABORATORY

*Proudly Operated by Battelle Since 1965*



# Technical Progress

## Task 1.1 - Fabrication, Assembly, and Testing of PPF Apparatus

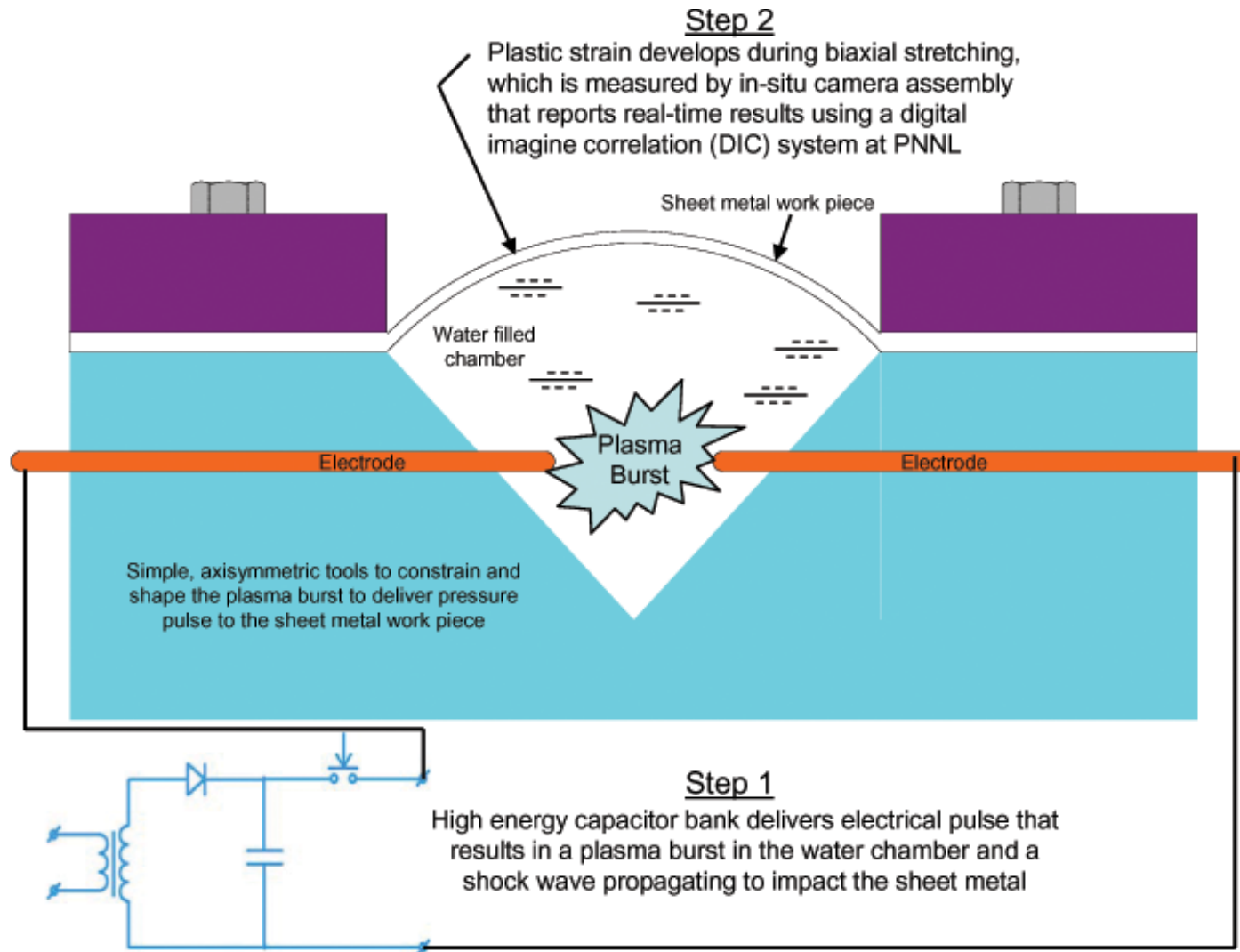

# Technical Progress

## Task 1.1 - Fabrication, Assembly, and Testing of PPF Apparatus

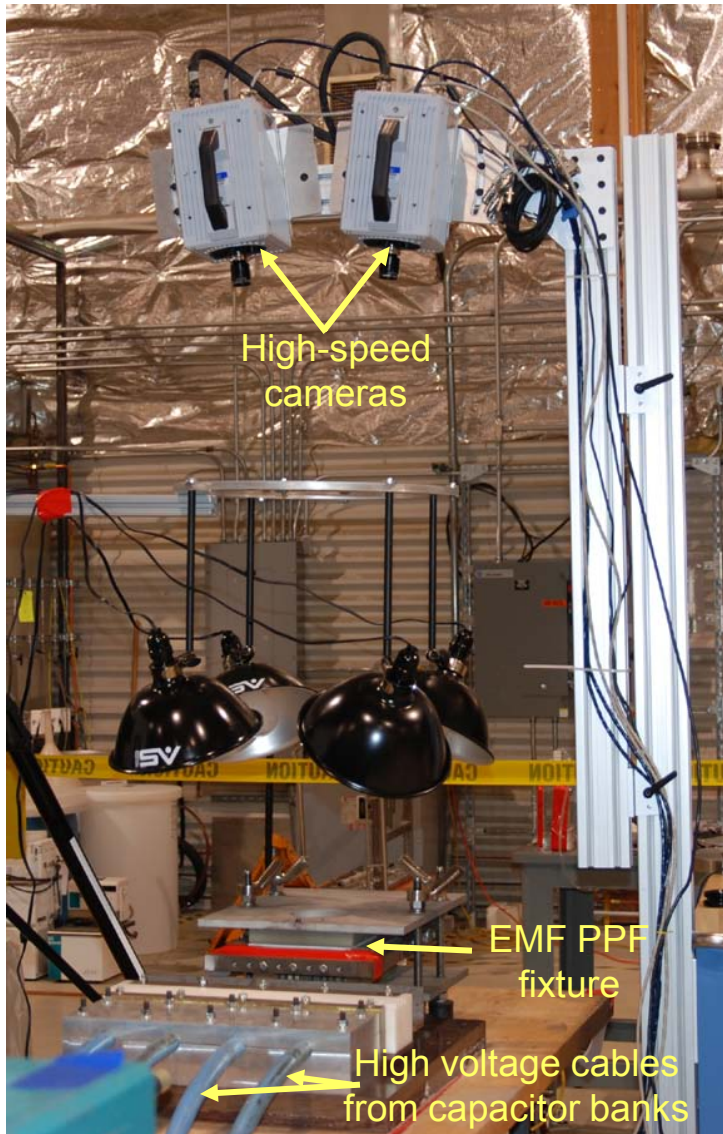

### Camera Capabilities

- ▶ Photron Fastcam SA1.1/5.1 High Speed Camera
- ▶ Image Acquisition
  - Sampling rate: 45,000 or 67,500 frames/second
  - Image size: 384 x 384 pixel
- ▶ Data Management
  - Use 'rolling buffer'; buffer contained several GB of data (Triggered manually)
  - Forming event was a small portion of overall data



# Technical Progress

## Task 1.1 - Fabrication, Assembly, and Testing of PPF Apparatus

### Deformation in Conical Die

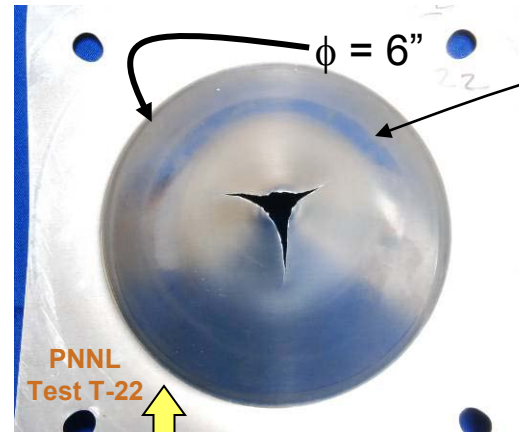
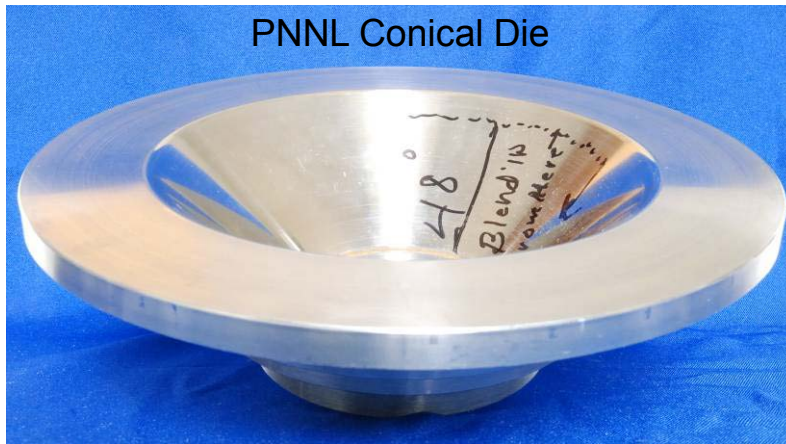

Conical die → Contoured dome  
Free-forming → Smooth dome

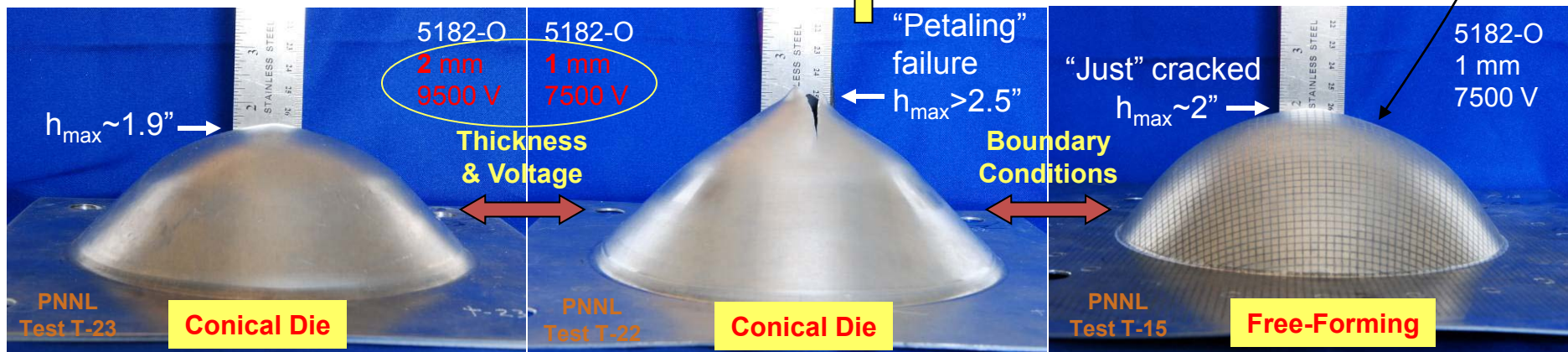

- Dome height: Conical die > Free-forming (same initial thickness and voltage).
- Thinner sheet failed at lower voltage while thicker sheet didn't fail at higher voltage.

# Technical Progress

## Single pulse PPF (Conical Die)

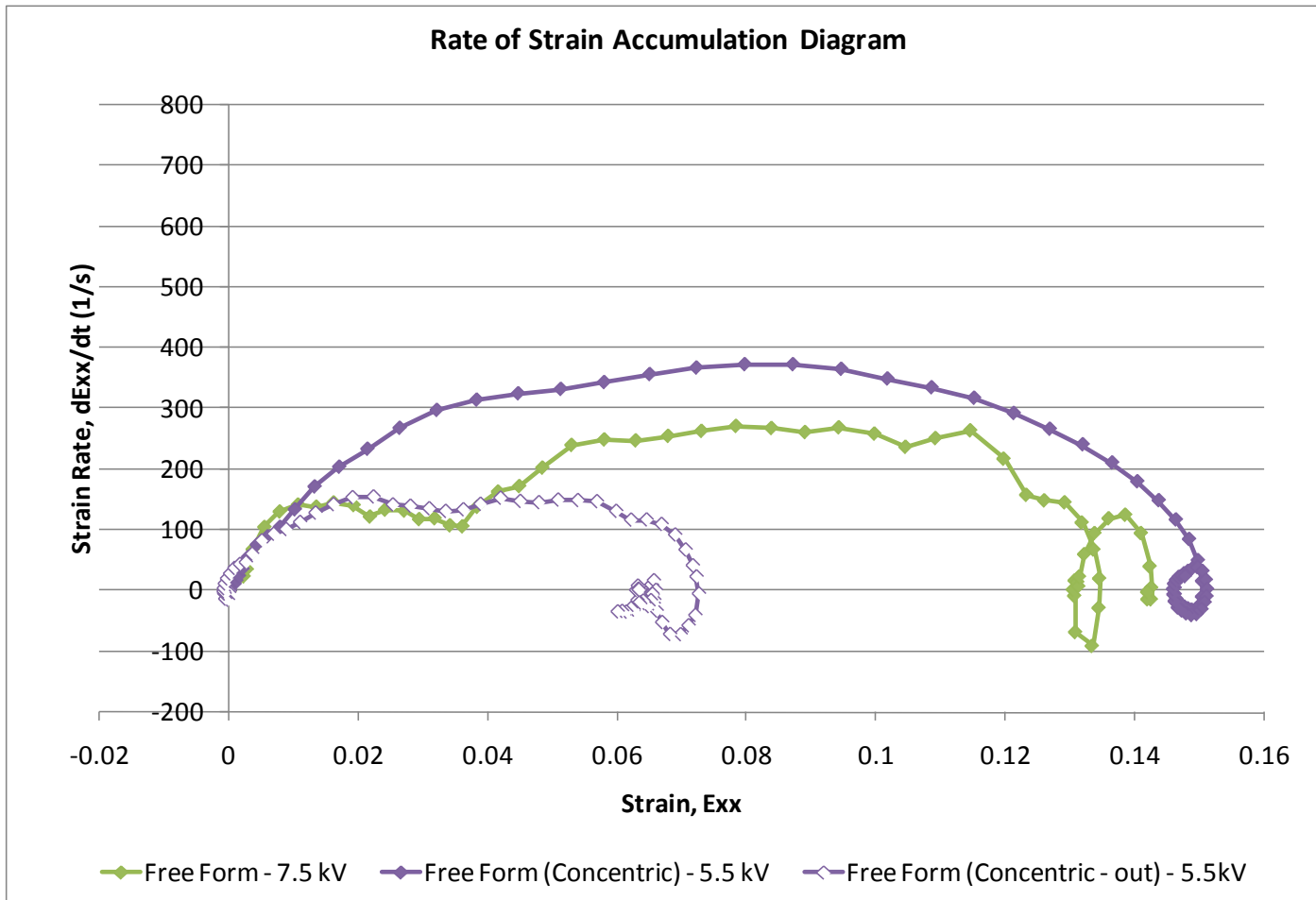

# Technical Progress

## Task 2.1 - Characterize constitutive relations

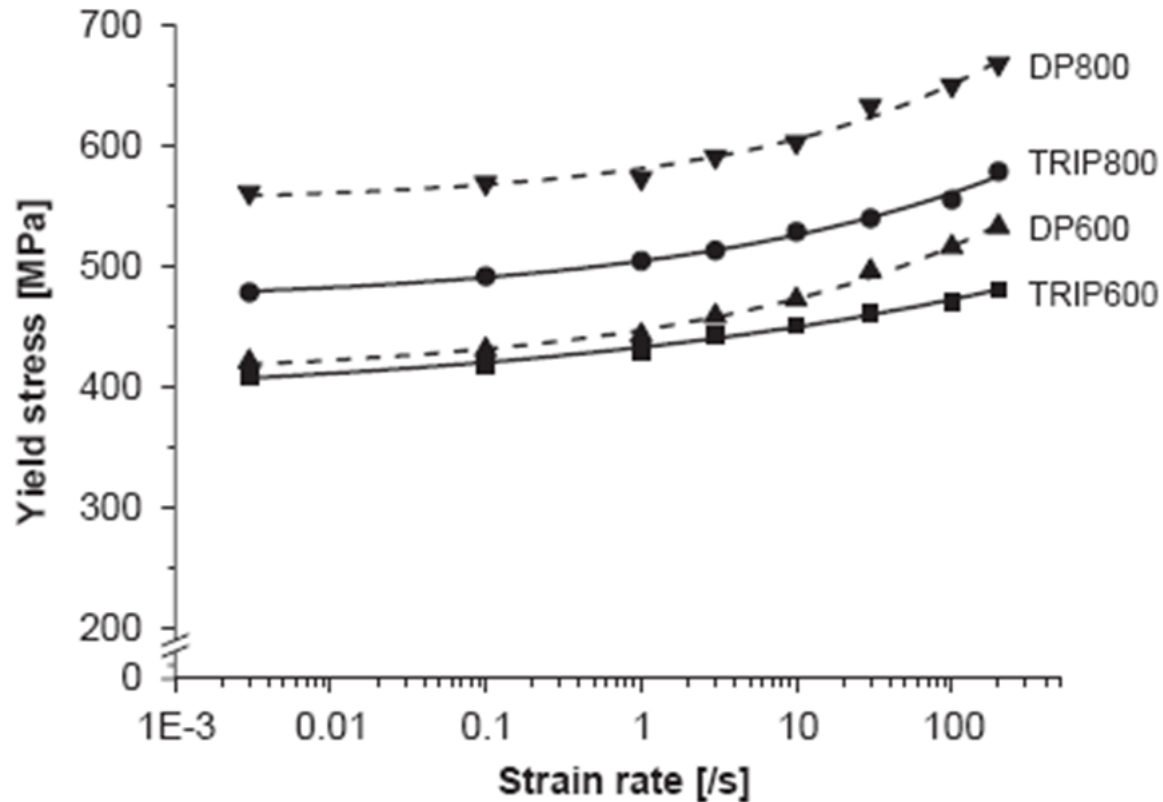

Yield stresses of TRIP-type and DP-type steel sheets at various strain rates

Huh H., et al., *Dynamic tensile characteristics of TRIP-type and DP-type steel sheets for an auto-body*. International Journal of Mechanical Sciences, 2008. **50**: p. 918 - 931.



Pacific Northwest  
NATIONAL LABORATORY

Proudly Operated by Battelle Since 1965

# Technical Progress

## Task 2.2 - Microstructure and texture evolution

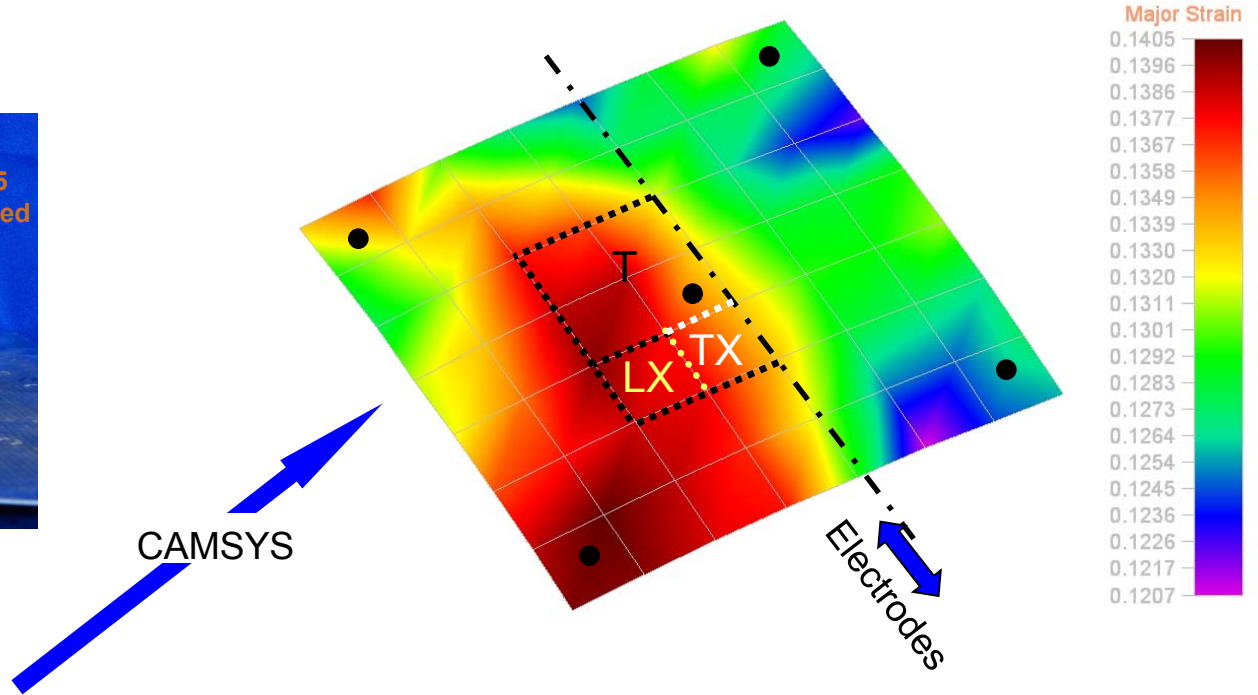
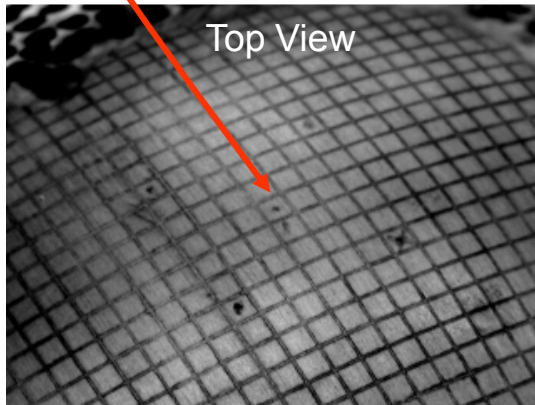
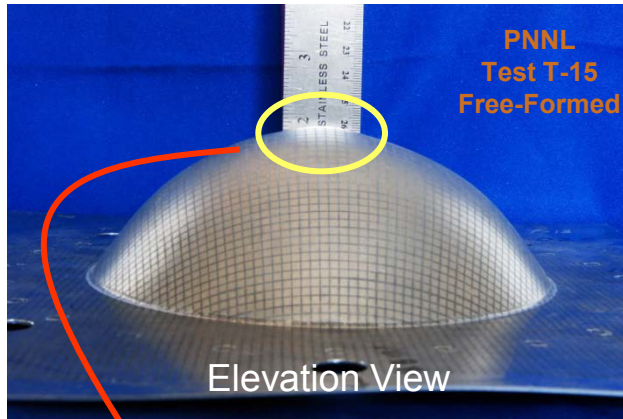

### Methods and Results of Strain Measurement

- High-speed DIC → live  $\epsilon$ ,  $\dot{\epsilon}$
- CAMSYS → post-mortem  $\epsilon$
- Manual → post-mortem  $\epsilon$

- ### Microstructure characterization
- Measuring strain-rate effects of high rate versus quasi-static
- EBSD and optical microscopy
  - Undeformed and deformed (dome apex)
  - Top (T), longitudinal (LX) and transverse (TX) cross-sections



**Pacific Northwest**  
NATIONAL LABORATORY

Proudly Operated by Battelle Since 1965

# Technical Progress

## Task 3.1 – Numerical Simulation of Sheet Forming

Developed ABAQUS-based model for free-forming and cone die forming – Revised to fit experiments

### ➤ ABAQUS/Explicit 6.8

### ➤ Elements types used for the metal sheet mesh

- Axisymmetric linear shell elements : SAX1
- 4-node bilinear axisymmetric 2D elements : CAX4R

### ➤ Type of loading

- Non-uniform distribution of the pressure on the bottom of the sheet.

$$P(x,t) = P(t) \left( 1 - \frac{x}{2L} \right), \quad 0 \leq x \leq L$$

- Pressure profile vs. time is established based on the experimental data of the vertical displacement/velocity of APEX obtained from the high speed camera recordings.

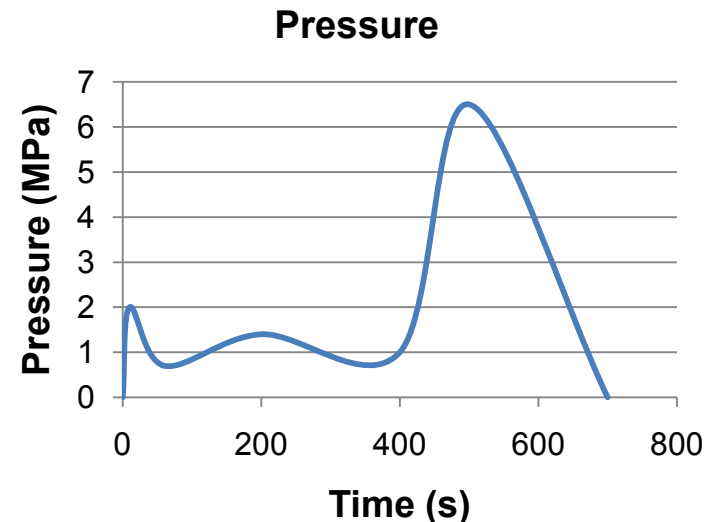
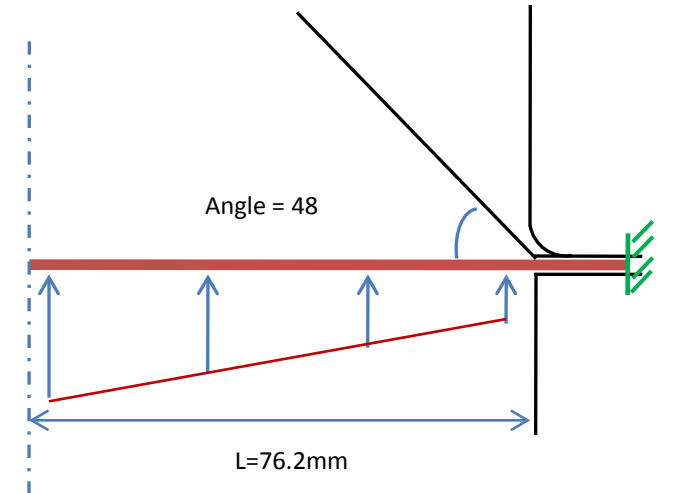

# Project Plan

## Technology transition including industry partners

- ▶ The project has an industrial team from the GM, Ford, and Chrysler that is:
  - Reviewing or project progress
  - Guiding our material and process priorities
  - Using our results for internal process development
- ▶ OEMs and Materials Suppliers have active development efforts that we inform through collaboration and delivery of our results



# Summary

- ▶ Completed fabrication, assembly, and testing of PPF apparatus
  - Direct experimental analysis of high rate forming events
  - High-speed camera DIC functions well – reliable results
  - Repetition shows some variability in dome height and strain
- ▶ Conical die magnifies maximum strain rate
  - True for both single- and multi-pulse
  - Strain rates above  $10^3/\text{sec}$  directly observed
- ▶ Measureable texture changes in the materials, and we are preparing high-rate versus quasi-static texture data
- ▶ Original pressure curve from literature used in FE models did not yield correlation with experimental results
- ▶ Project proceeding according to plan



# Supplementary Slides



**Pacific Northwest**  
NATIONAL LABORATORY

*Proudly Operated by Battelle Since 1965*

# Introduction - Technical Barriers

- ▶ lack of understanding of the formability and strain rates that develop during PPF processing
- ▶ lack of validated constitutive relations for lightweight materials during PPF processing
- ▶ lack of validation of finite element simulation of PPF processing

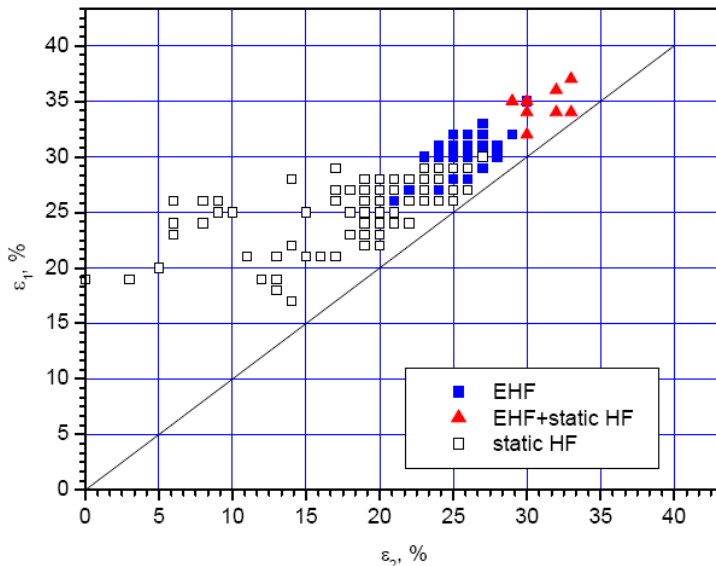

Experimental results on formability of AA6111-T4 sheet with HF, EHF and HF+EHF

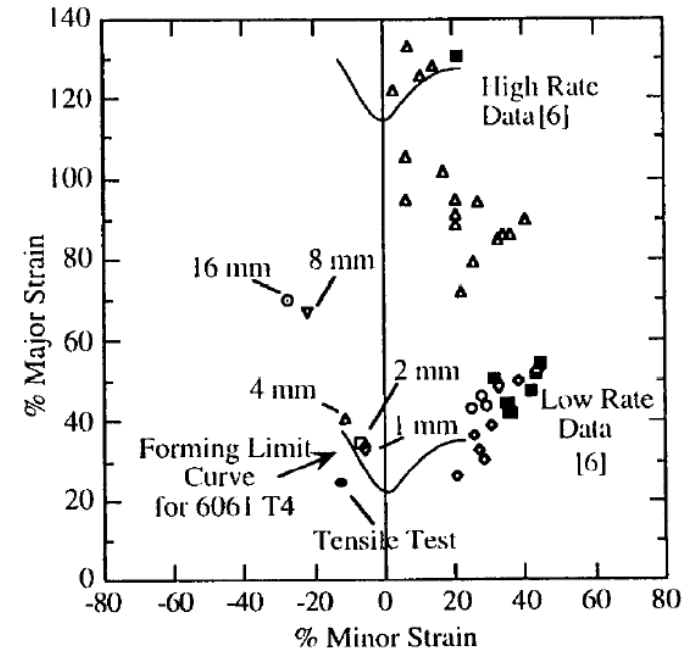

Pacific Northwest

Tamhane, A; Altynnova, M; Daehn, G.; 1996. Effect of Sample Size on the Ductility in Electromagnetic Ring Expansion; Scripta Materialia, Vol. 34, No. 8, pp 1345-1350

Golovashchenko, S; and Mamutov, V.; 2005. Electrohydraulic Forming of Automotive Panels; Symposium on Global Innovations in Materials Processing & Manufacturing, TMS.

# Project Plan

- ▶ Task 1: Formability and Fracture of Metals during PPF
  - 1.1 - Fabrication, assembly, and testing of PPF apparatus (complete)
  - 1.2 - Single-pulse PPF
  - 1.3 - Multi-pulse PPF
  - 1.4 - Conventional preforming and single-pulse PPF (restrike)
- ▶ Task 2: Microstructure and Mechanical Property Evolution during PPF
  - 2.1 - Characterize constitutive relations
  - 2.2 - Microstructure and texture evolution
  - 2.3 - Post-forming properties of materials subject to PPF
- ▶ Task 3: Numerical Simulation of PPF Process
  - 3.1 - Sheet forming
  - 3.2 – Sheet-die interaction



# Project Plan

Quarter	Fiscal Year 2008				Fiscal Year 2009				Fiscal Year 2010				Fiscal Year 2011				Fiscal Year 2012			
	Q 1	Q 2	Q 3	Q 4	Q 1	Q 2	Q 3	Q 4	Q 1	Q 2	Q 3	Q 4	Q 1	Q 2	Q 3	Q 4	Q 1	Q 2	Q 3	Q 4
<b>Task 1: Formability and Fracture</b>																				
1.1 PPF Apparatus			█	█																
1.2 Single pulse PPF					█	█	█	█	█	█										
1.3 Multiple pulse PPF							█	█	█	█	█	█	█							
1.4 PPF Restrike											█	█	█	█	█	█				
<b>Decision Gate</b>							█													
	Complete: functional test apparatus to characterize strain and strain rate during PPF and successful determination of formability																			
<b>Task 2: Microstructure and mech. property evolution</b>																				
2.1 Constitutive relations			█	█	█	█	█	█	█											
2.2 Microstructure and texture evolution					█	█	█	█	█	█	█	█	█	█	█					
2.3 Post-forming properties										█	█	█	█	█						
<b>Decision Gate</b>										█										
	Pending: validated constitutive relations of Al, Mg, and HSS/AHSS sheet materials during PPF																			
<b>Task 3: Numerical simulation</b>																				
3.1 Sheet Forming			█	█	█	█	█	█	█											
3.2 Sheet-Die Interaction										█	█	█	█	█						



# Project Plan

## Detailed Gap Analysis

	<b>Technical challenges</b>	<b>Today</b>	<b>Tomorrow</b>	<b>how to get there</b>
<b>Task 1</b>	<b>Formability and Fracture of Metals during PPF</b>			
1A	lack of method to characterize strain rate during PPF	No detailed understanding of strain rates during PPF processes	Apparatus to measure strain rates during PPF	1.1
1B	lack of understanding of the strain rates and strain rate variability developed during PPF	Estimates of strain rate based on total deformation in final parts/specimens and estimated process time process	A detailed understanding of the variable strain rate developed during single pulse PPF	1.2
1C	Lack of understanding of the influence of incremental PPF on sheet metal formability.	Some experience suggest incremental PPF may be more favorable than single pulse PPF from an overall material formability and properties standpoint.	A detailed understanding of how incremental forming influences sheet metal formability and properties	1.3-1.4
<b>Task 2</b>	<b>Microstructure and mechanical property evolution during PPF</b>			
2A	Lack of validated constitutive relations for automotive materials during PPF processing	Understanding of the detailed strain rate and strain rate variability during PPF processes is unknown	PPF laboratory experiments that detail strain rates, and a set of validated constituent relations for relevant automotive materials	2.1
2B	Lack of understanding of the microstructure and post-forming properties of materials subject to PPF	Most R&D limited to formability investigations, with limited research on the microstructure evolution and post-forming properties	Complete investigation of the microstructure and crystallographic texture evolution during PPF, and a detailed characterization of the post-forming properties of automotive lightweight materials.	2.2-2.3
<b>Task 3</b>	<b>Numerical simulation of PPF process</b>			
3A	Limited constitutive relations and detailed experimentation to validate FEA of PPF	PPF is a process that has a duration of microseconds, and little or no detailed strain data is available for validation	Detailed characterization of the strain rate coupled with numerical simulation comparisons to validate FEA predictions of PPF	3.1-3.2

# Technical Progress

## Task 1.1 - Fabrication, Assembly, and Testing of PPF Apparatus

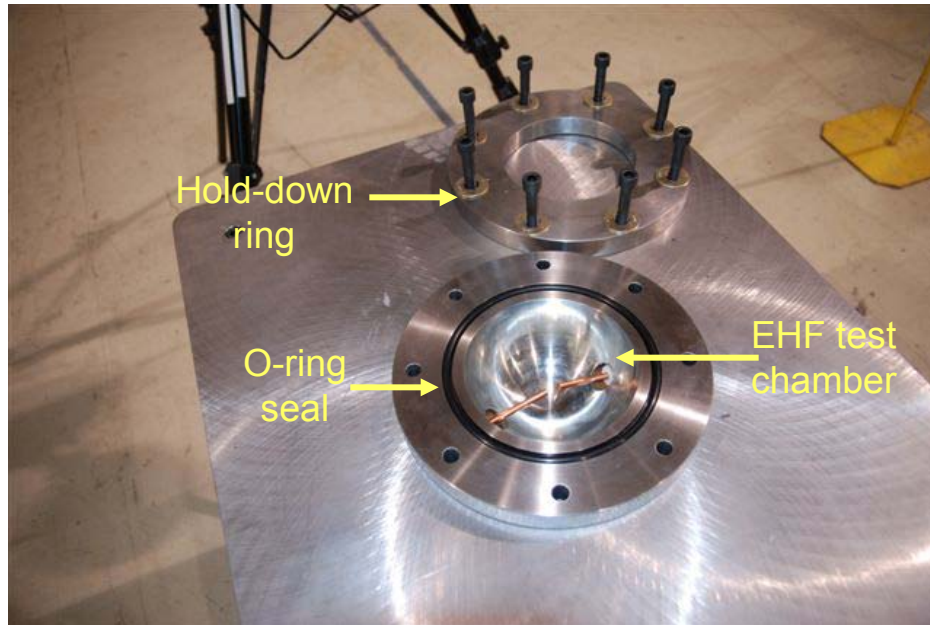

Exploded view of Pulse Pressure Forming set-up.

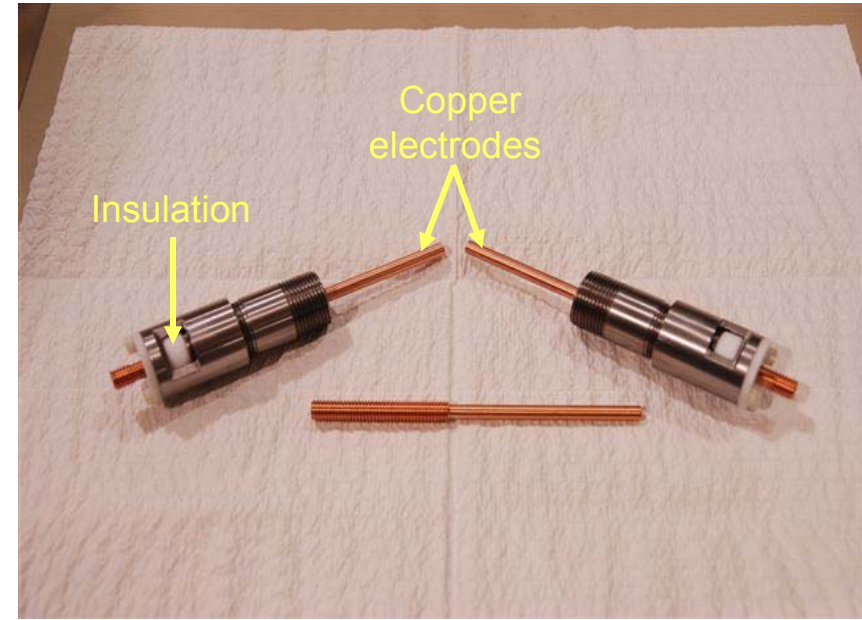

Electrode assemblies and a bare electrode used of Pulse Pressure-Forming set-up.

# Technical Progress

## Task 1.1 - Fabrication, Assembly, and Testing of PPF Apparatus

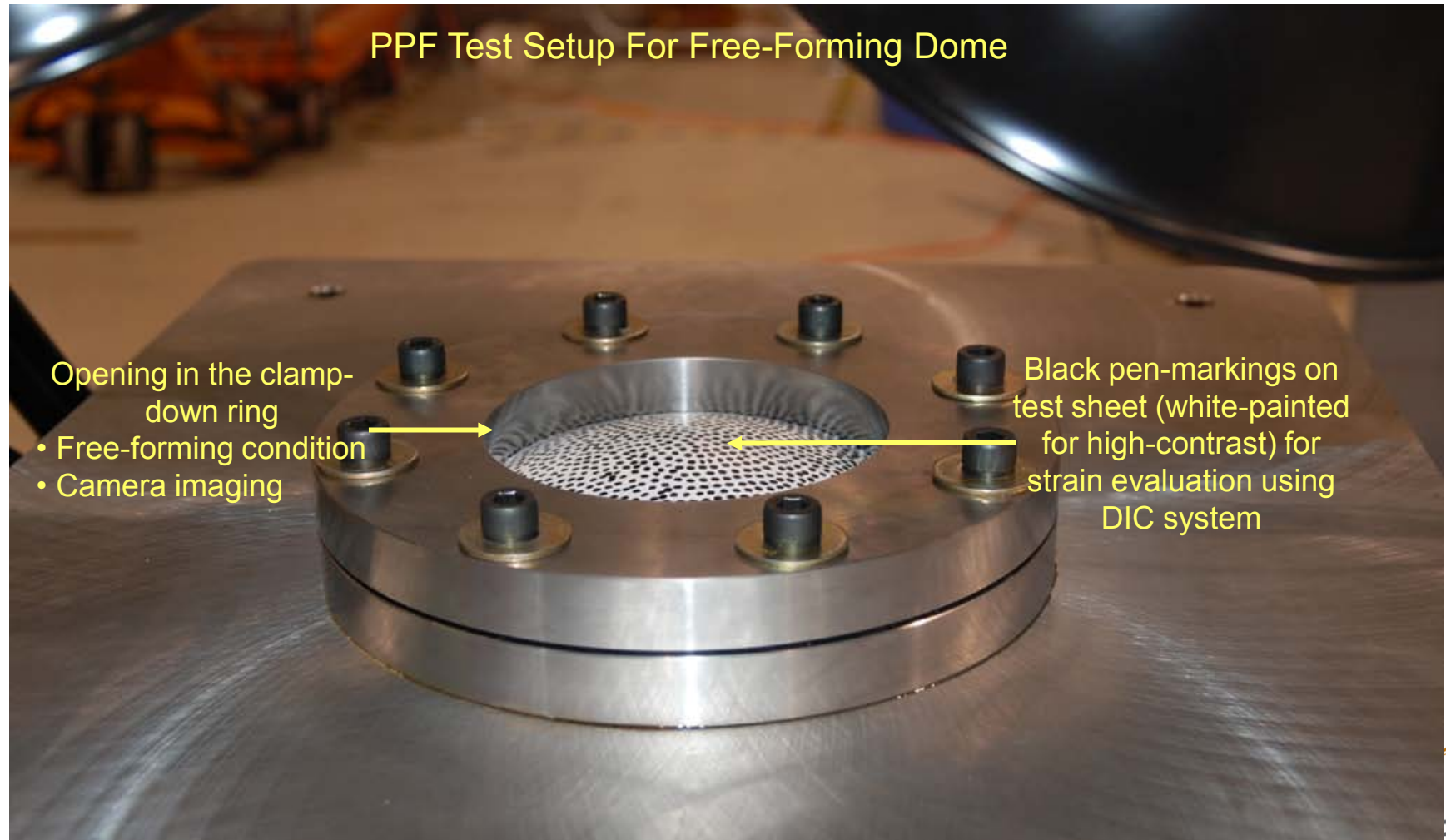

NATIONAL LABORATORY



# Technical Progress

## Task 1.2 - Single-pulse PPF

Top View: Free-Forming

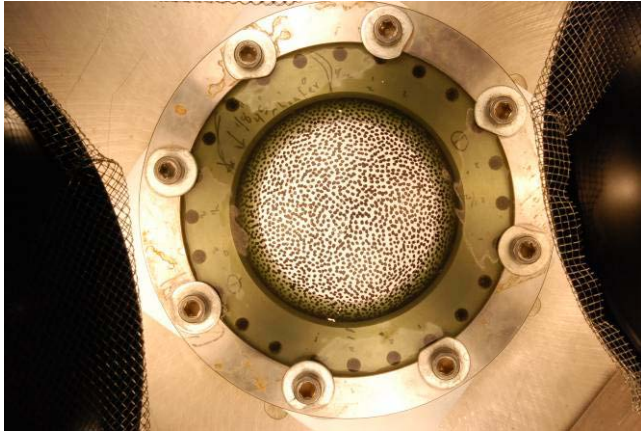

Imaging Setup



Close-up of Cameras

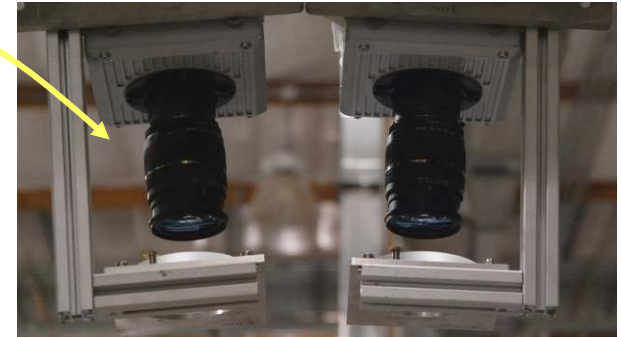

Side View: Cone Die



Looking Inside Conical Die

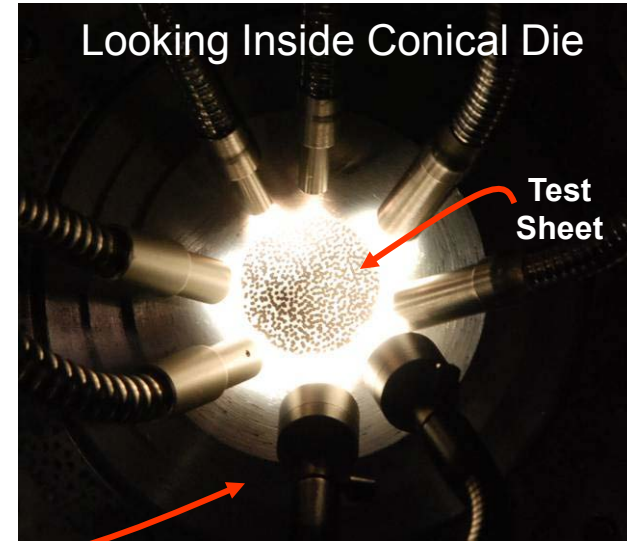

# Technical Progress

## Task 1.2 - Single-pulse PPF

Free Forming vs. Conical: 5182-O Aluminum 1mm, 7.5kV

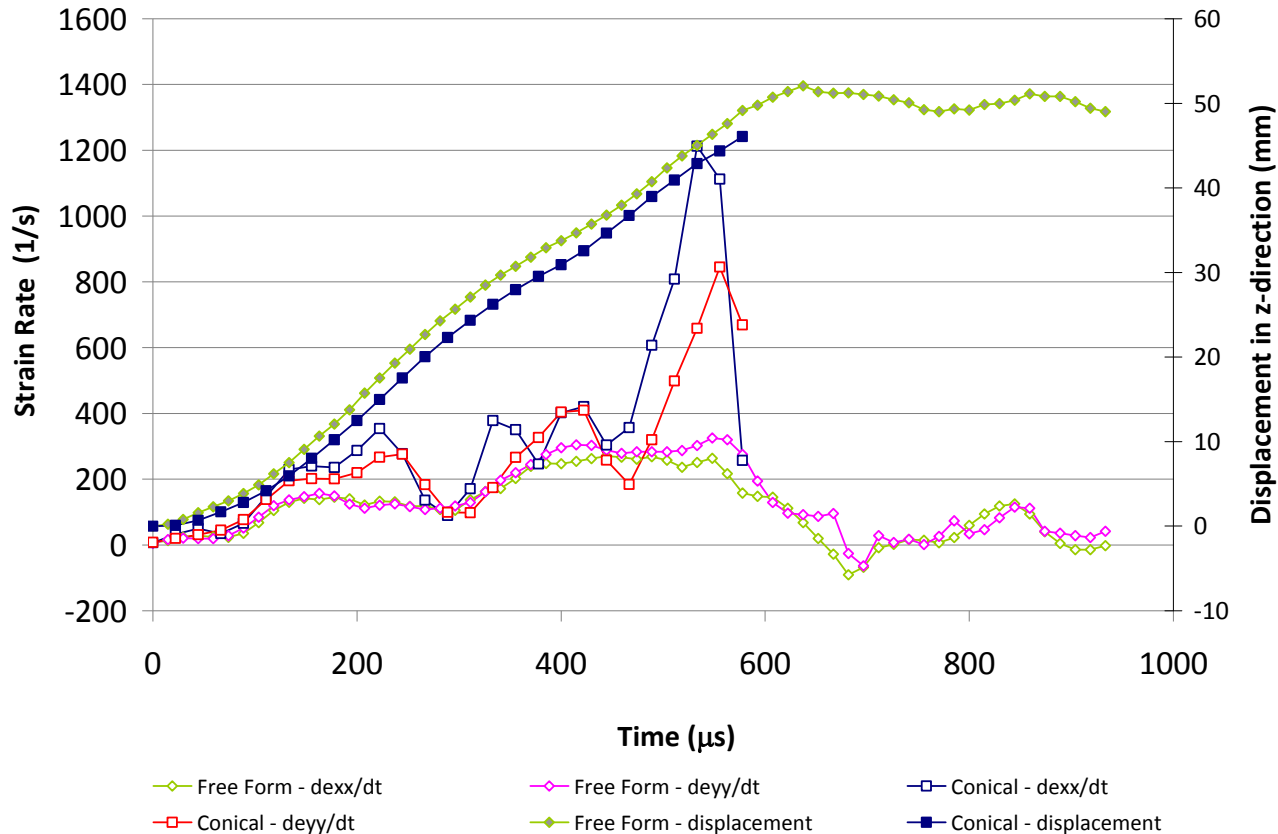

Comparison of the strain rate and displacement at the dome apex for the sheet metal under both free forming and conical die forming.



Pacific Northwest  
NATIONAL LABORATORY

Proudly Operated by Battelle Since 1965

# Technical Progress

## Task 1.2 - Single-pulse PPF

Vertical Velocity of Center of Dome: 5182-O Aluminum 1mm

Forming Velocity normal to the blank free surface

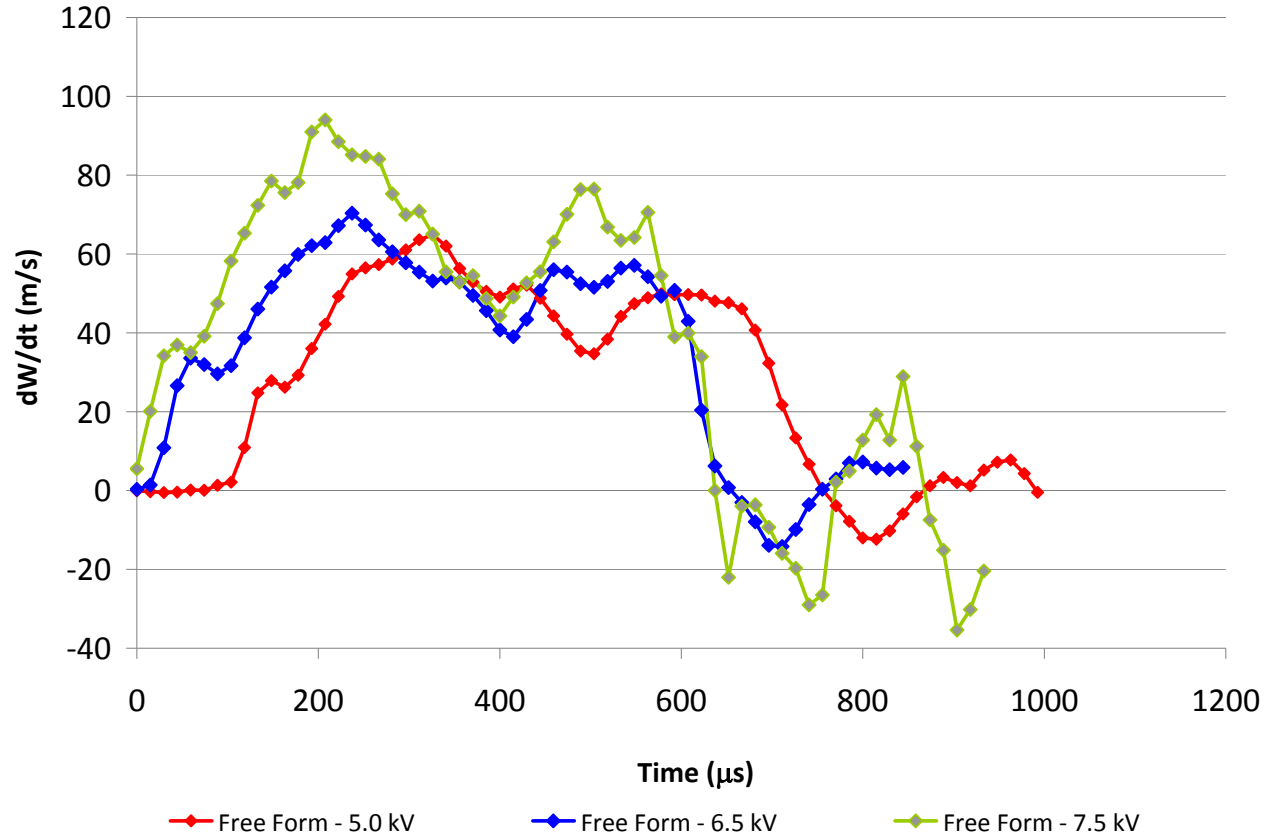

Comparison of the sheet velocity at the dome apex for the sheet metal under three two energy levels in free forming.

# Technical Progress

## Task 1.2 - Single-pulse PPF

Free Form vs. Conical: DP600 Steel 1mm, 9.5kV

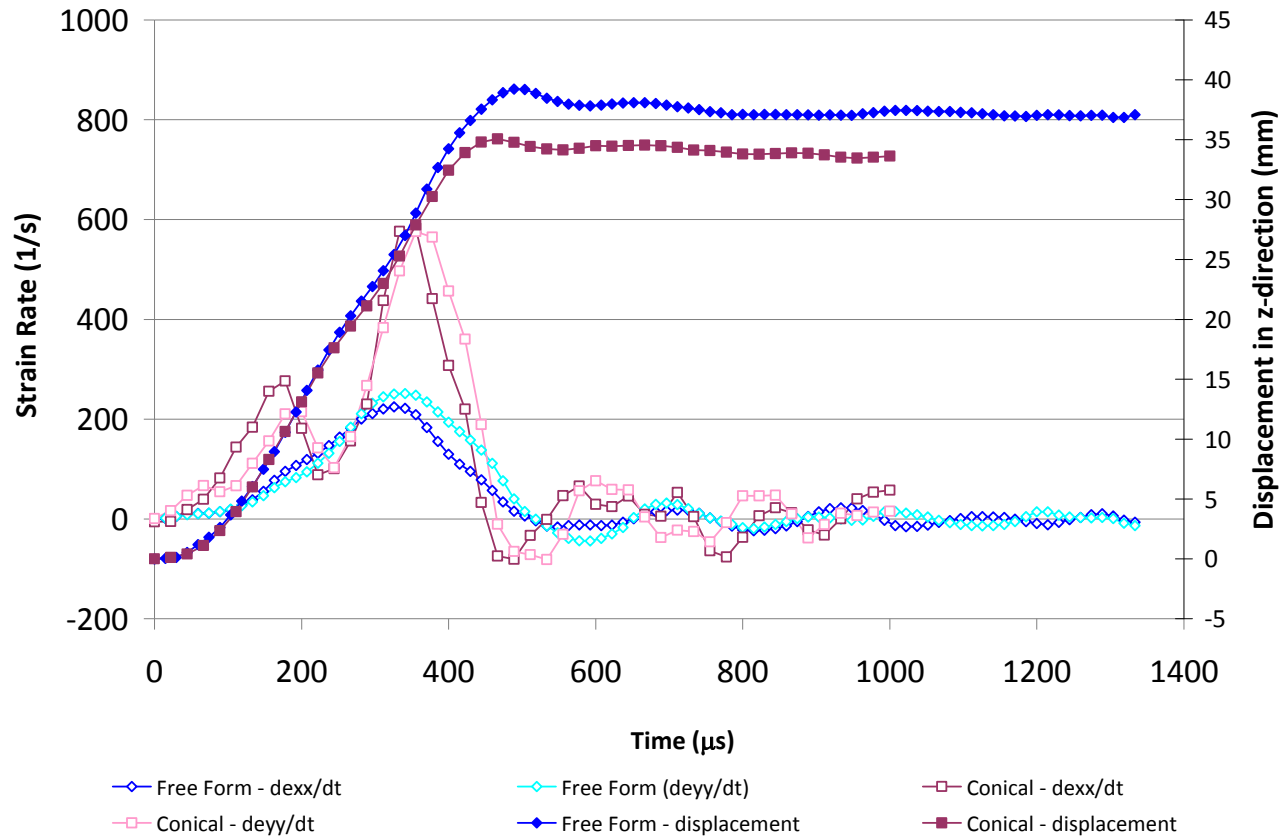

Comparison of the strain rate and displacement at the dome apex for the DP600 sheet metal under both free forming and conical die forming.



Pacific Northwest  
NATIONAL LABORATORY

Proudly Operated by Battelle Since 1965

# Technical Progress

## Task 1.3 - Multi-pulse PPF (Conical Die)

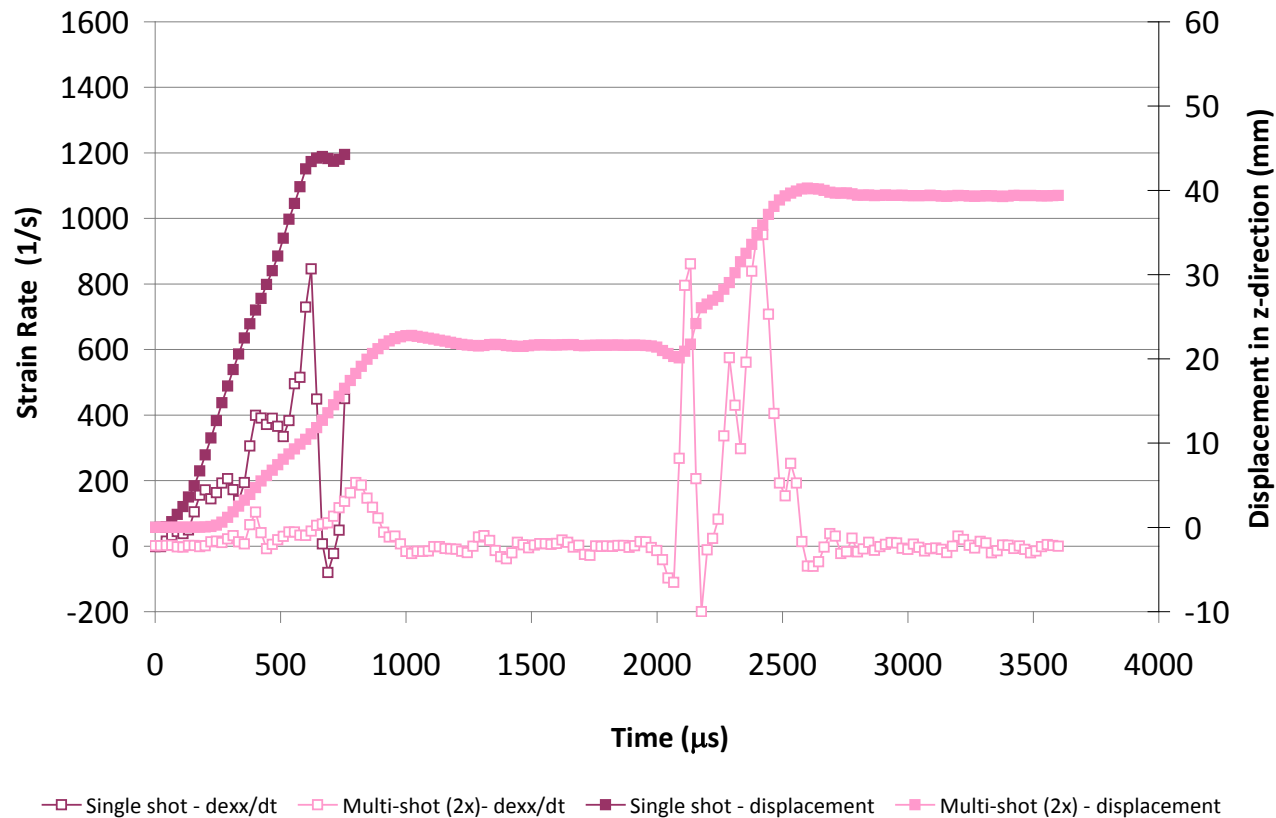

Comparison of the strain rate and displacement at the dome apex for single-pulse and multi-pulse under conical die forming.

# Technical Progress

## Task 1.2-1.3 – Forming Limit Data

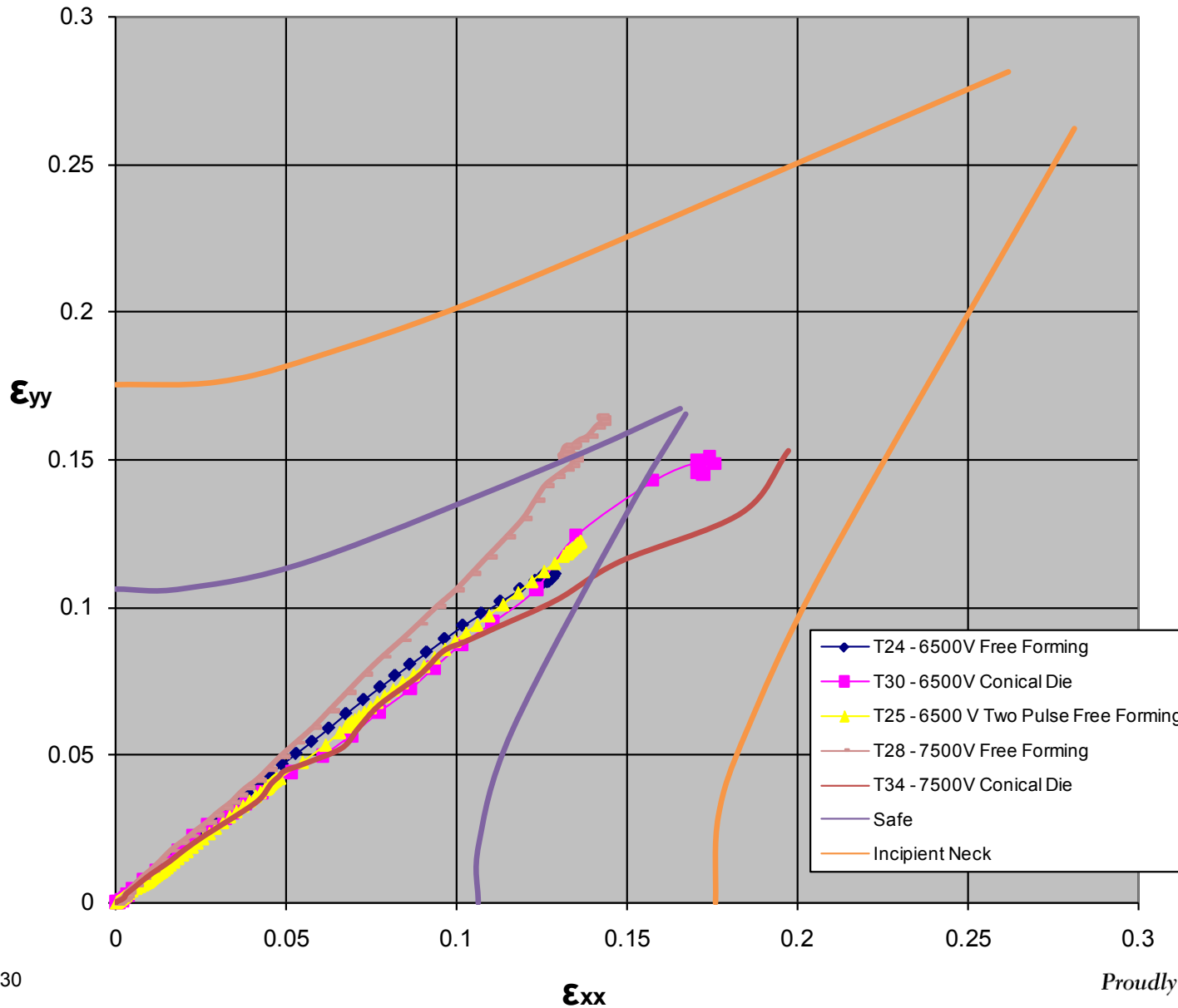

# Technical Progress

## Task 1.2-1.3 – Forming Limit Data

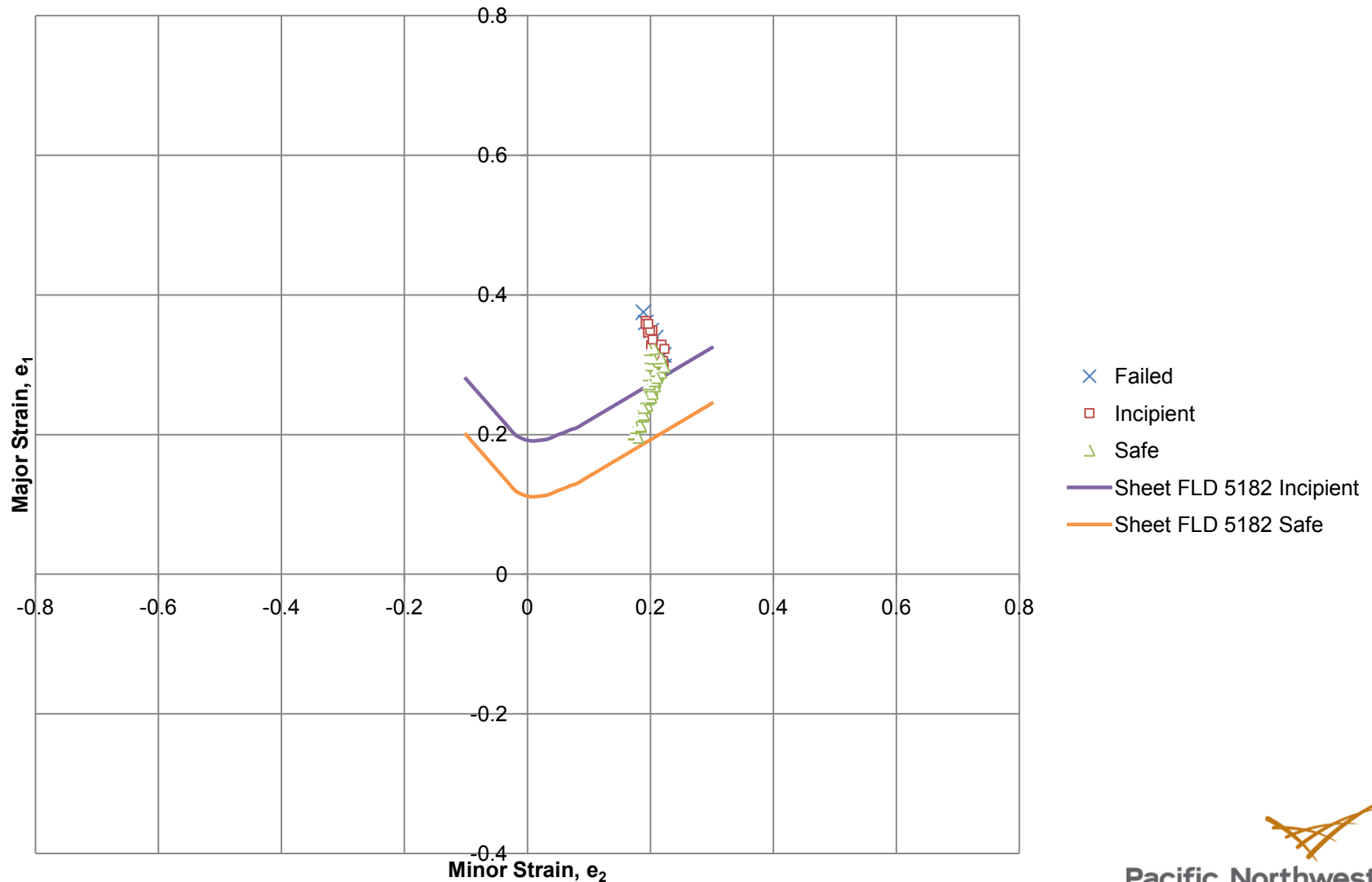

# Technical Progress

## Task 2.1 - Characterize Constitutive Relations

- ▶ Literature search is complete
  - Selected literature survey of testing methods and results relative to materials of interest.
  - Survey of ductile fracture models suitable for variable strain rates.
  - Survey of constitutive modeling approaches for high strain rate material behavior.



**Pacific Northwest**  
NATIONAL LABORATORY



# Technical Progress

## Task 2.1 - Characterize constitutive relations

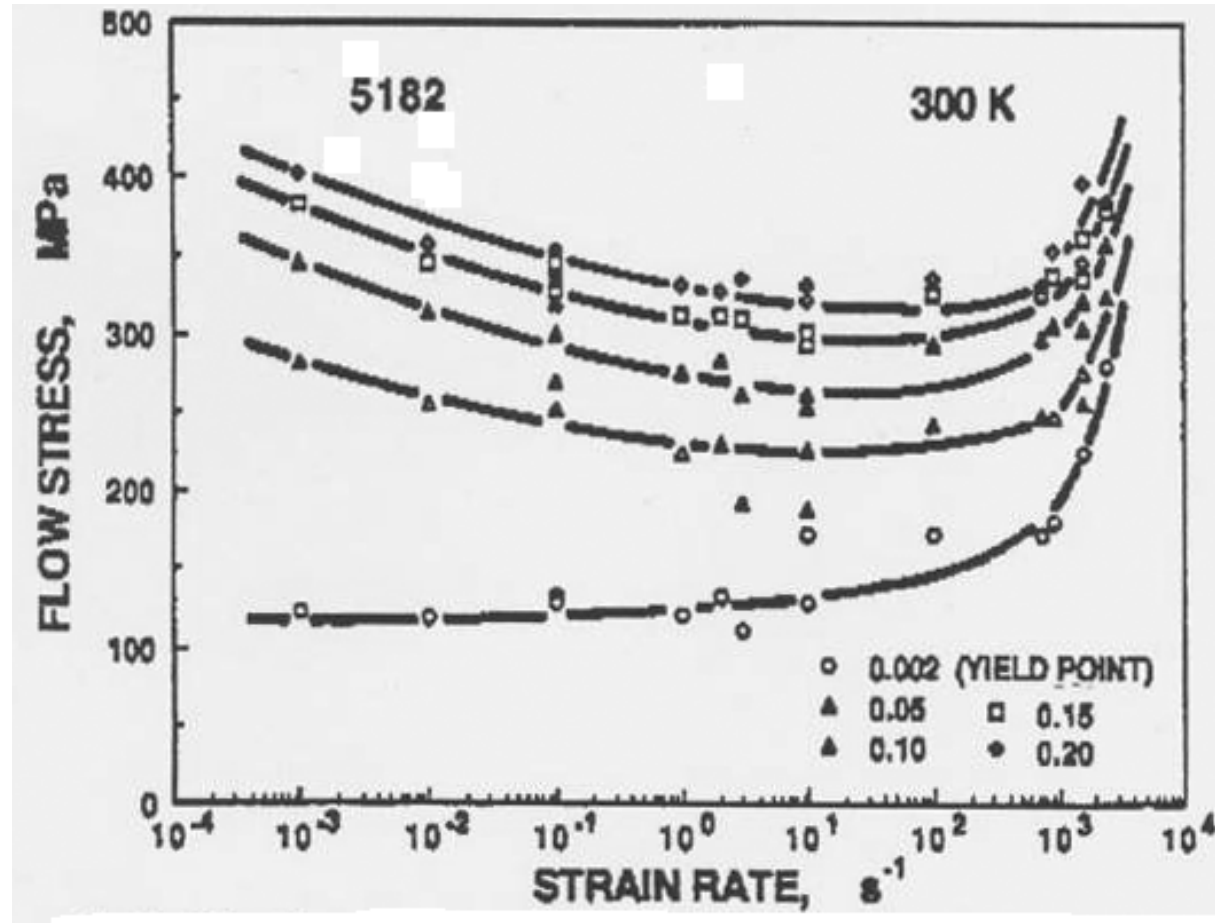

Higashi, K., et al., *The Microstructural Evolution During Deformation under Several Strain Rates in Commercial 5182 Aluminum Alloy*. Journal De Physique IV, Colloque C3, October 1991. p. 347-352.



Pacific Northwest  
NATIONAL LABORATORY

Proudly Operated by Battelle Since 1965

# Technical Progress

## Task 2.2 - Microstructure and texture evolution 5182-O, 1mm (Sheet Normal)

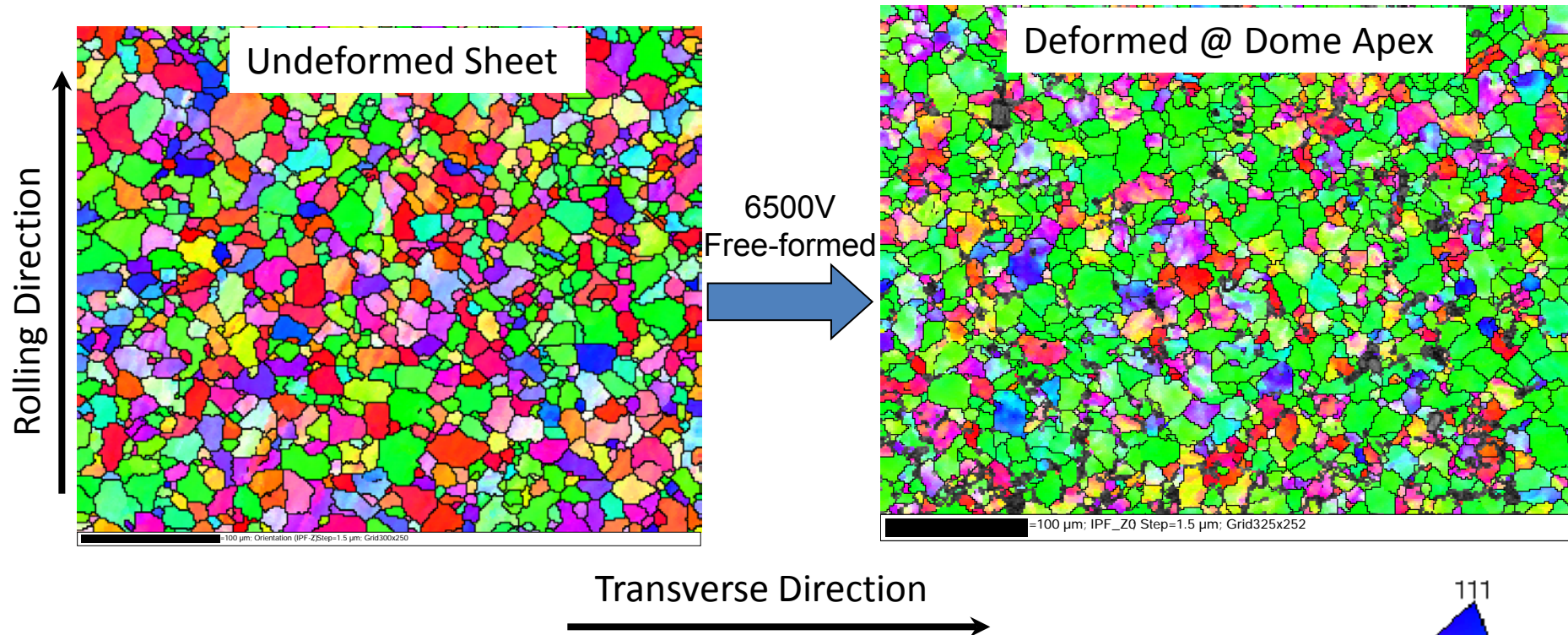

- Deformation
- Dome height
    - 1.602" (manual) vs. 1.575" (DIC camera)
  - Thickness strain
    - 18.8% (manual) vs. 20.1% (DIC camera)

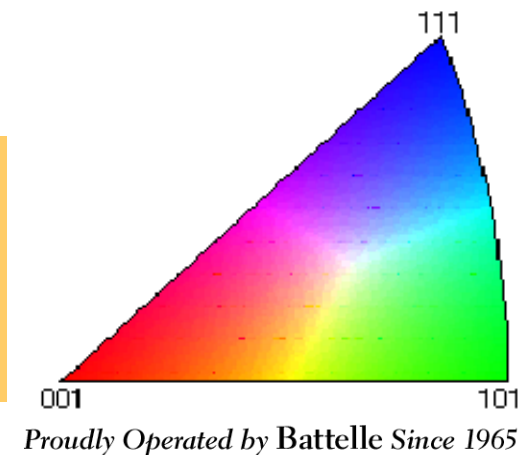

# Technical Progress

## Task 2.2 - Microstructure and texture evolution 5182-O, 1mm (Sheet Normal)

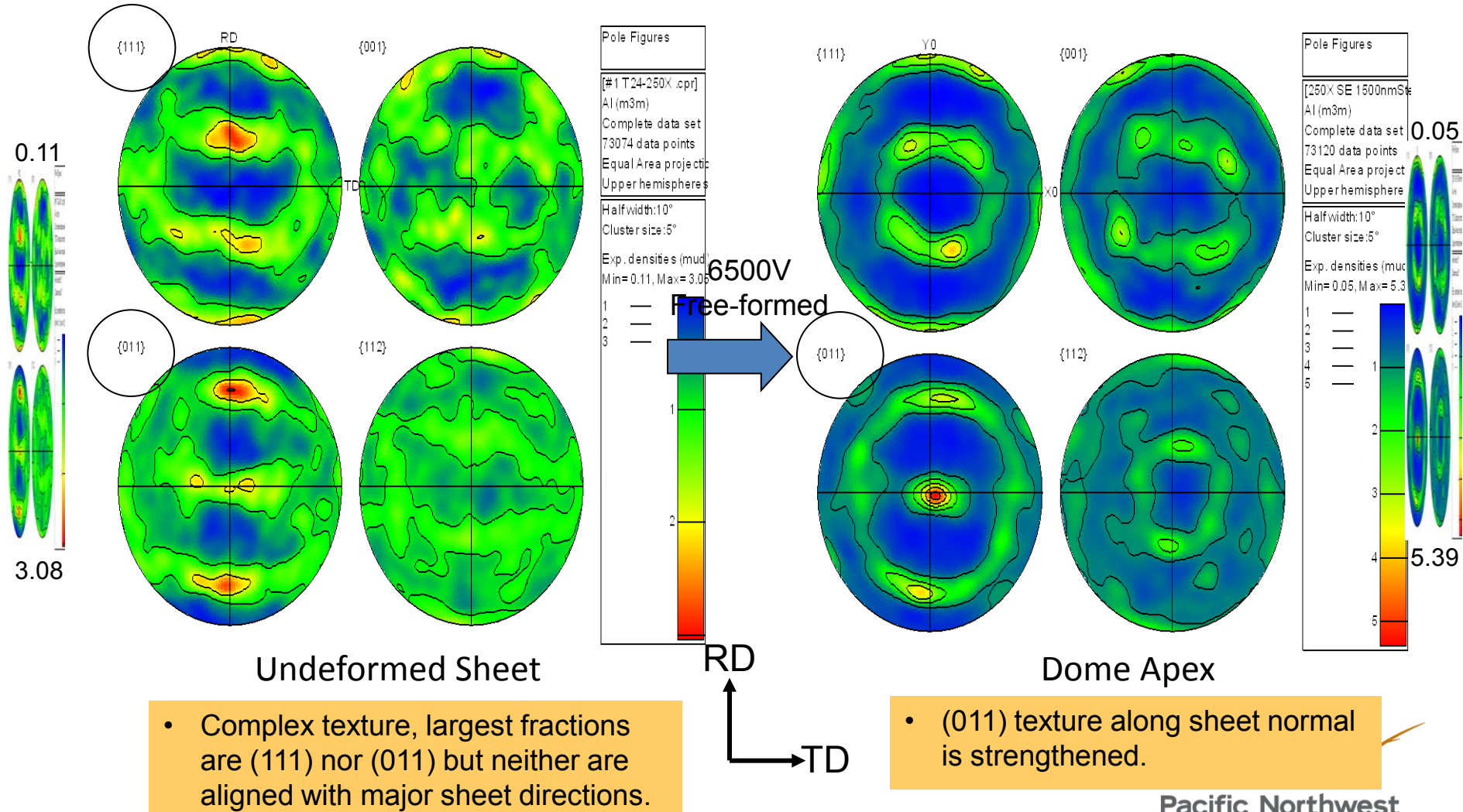

- Complex texture, largest fractions are (111) nor (011) but neither are aligned with major sheet directions.

- (011) texture along sheet normal is strengthened.

# Technical Progress

## Task 3.1 – Numerical Simulation of Sheet Forming

Developed ABAQUS-based model for free-forming and cone die forming – From Literature

- **ABAQUS/Explicit 6.8**
- **Elements types used for the metal sheet mesh**
  - Axisymmetric linear shell elements : SAX1
  - 4-node bilinear axisymmetric 2D elements : CAX4R
- **Type of loading**
  - Uniform pressure on the bottom of the sheet
  - Pressure profile assumed as (1, 2):

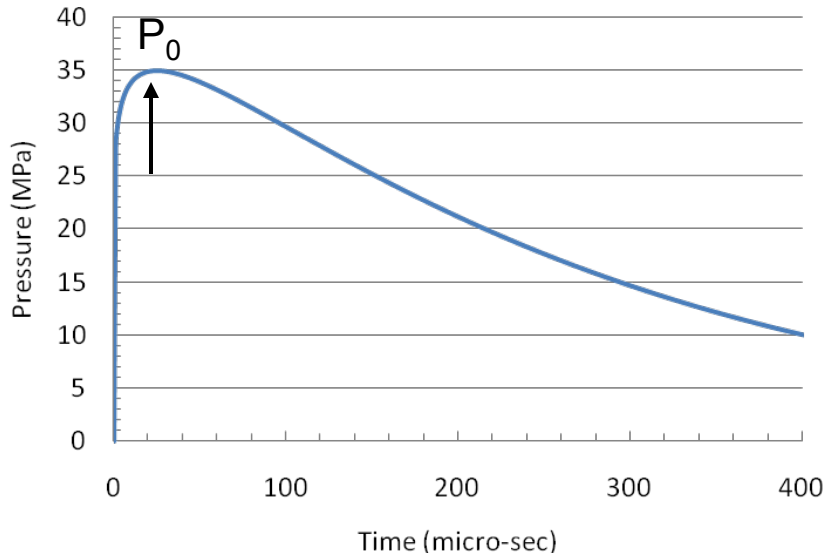
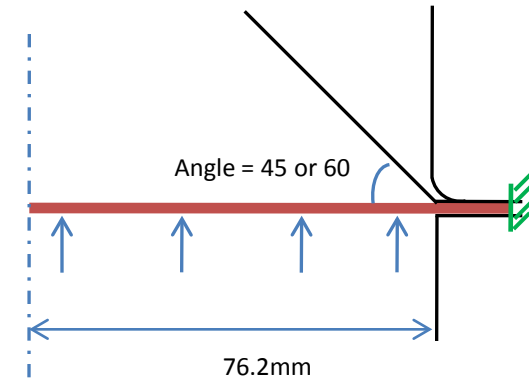

(1) Guliy, 1990 - (2) Vagin et al., 1990 - (3) Smerd R., et al., 2005

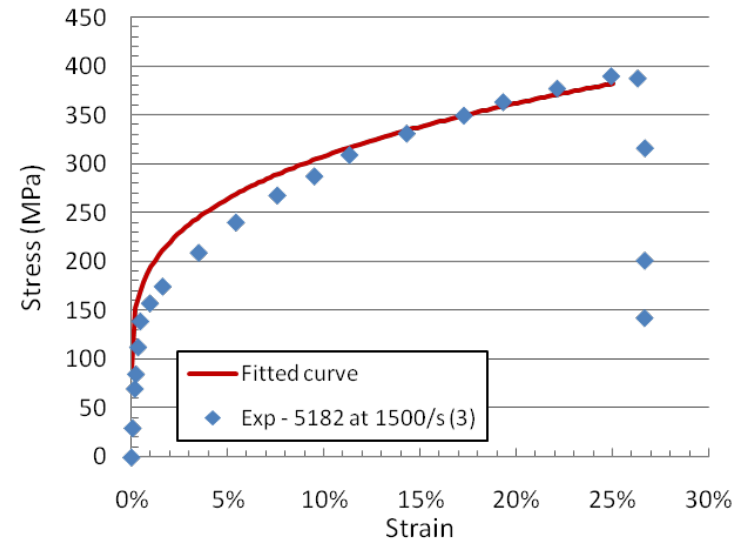

**Pacific Northwest**  
NATIONAL LABORATORY

*Proudly Operated by Battelle Since 1965*

# Technical Progress

## Task 3.1 – Numerical Simulation of Sheet Forming

Comparison of experimental and simulation vertical velocity for Al5182, 1mm, 6.5kV

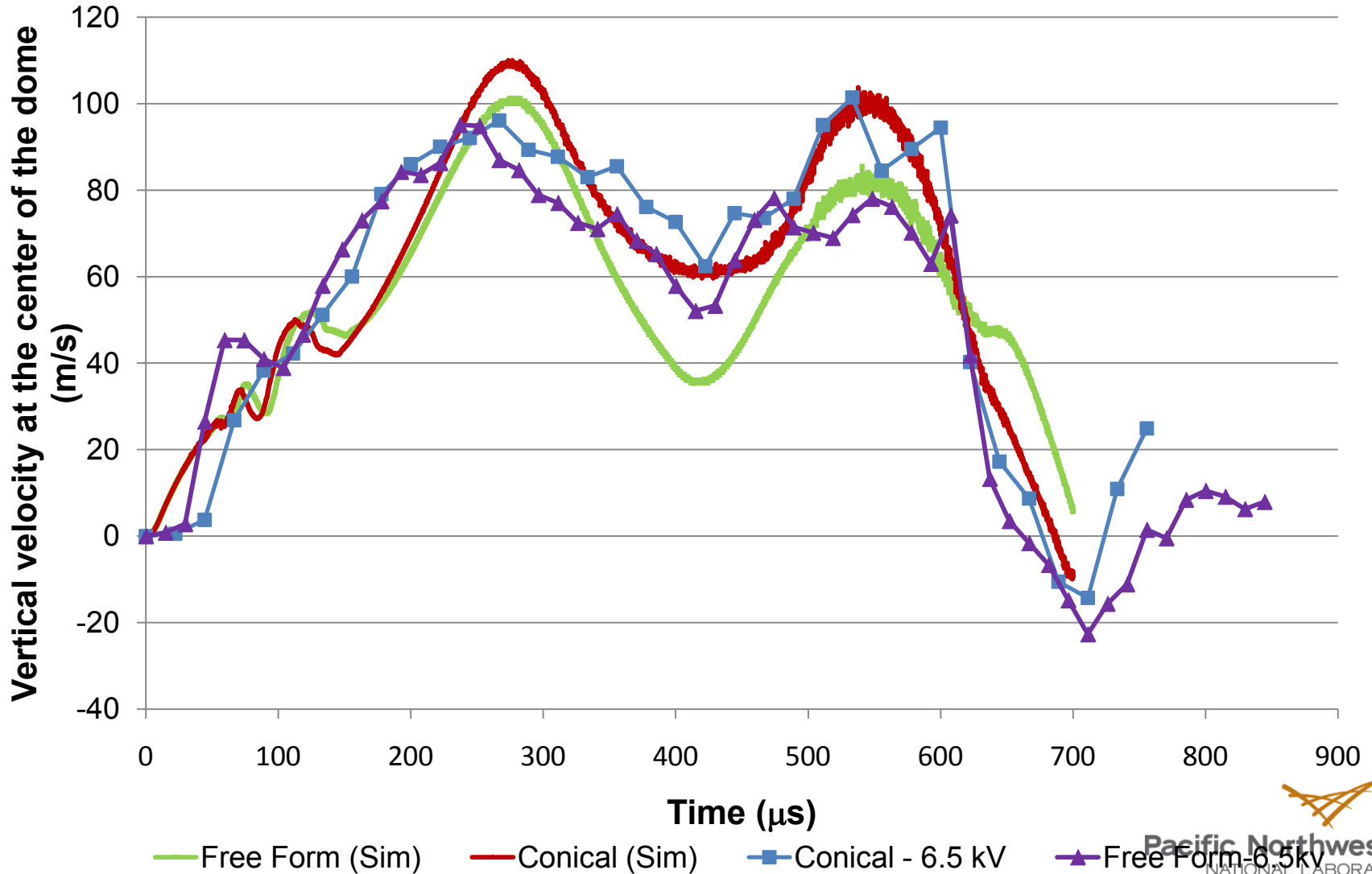

# Technical Progress

## Task 3.1 – Numerical Simulation of Sheet Forming

Comparison of experimental and simulation strain rates for Al5182, 1mm, 6.5kV

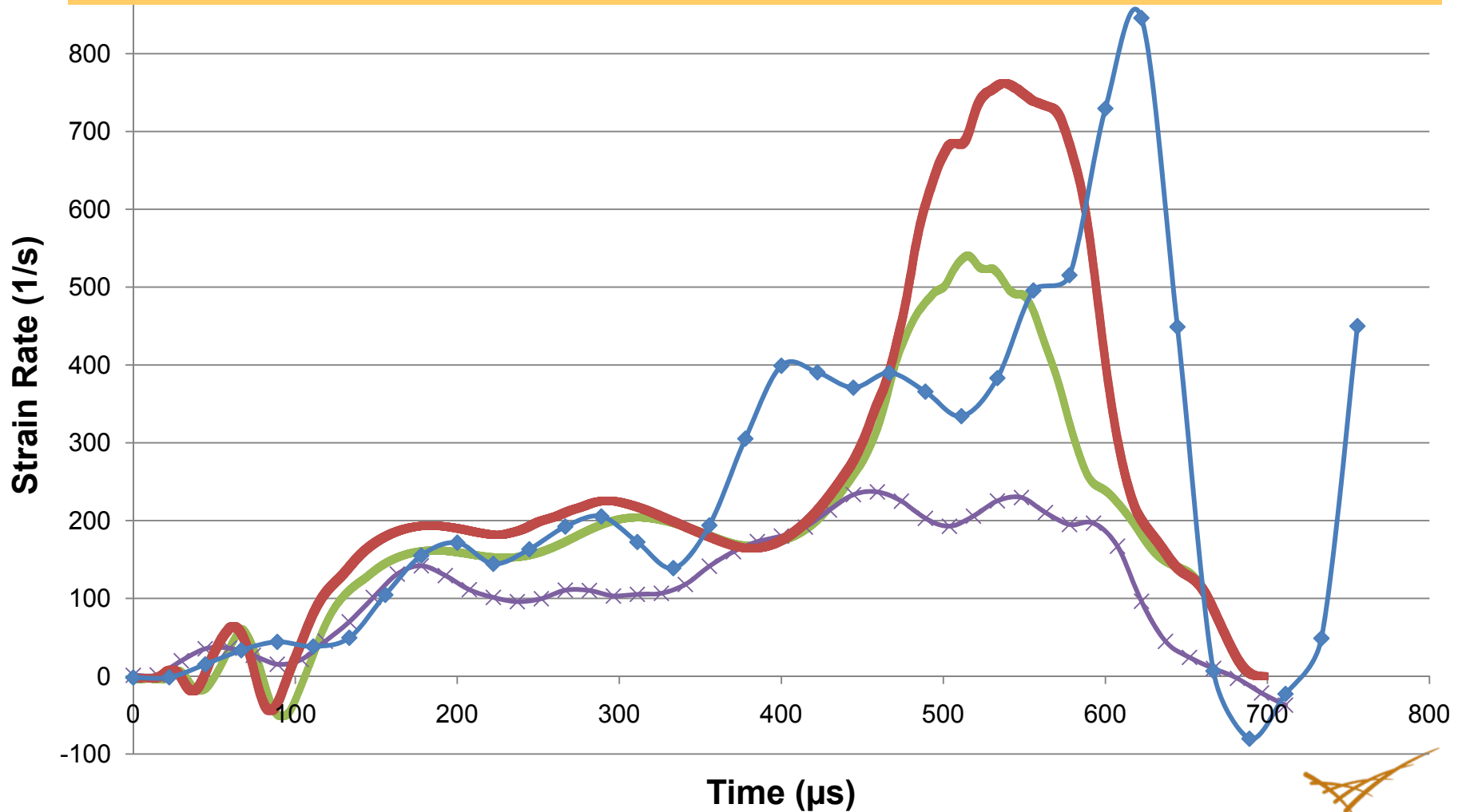

— Sim-Free Form - dExx/dt  
— Sim-Conical Die - dExx/dt

— Exp-Free Form 6.5kV - dExx/dt  
— Exp-Conical Die 6.5kV - dExx/dt

# Future Work

## PPF Task Plan

- ▶ Task 1: Formability and Fracture of Metals during PPF
  - 1.1 - Fabrication, Assembly, and Testing of PPF Apparatus
  - 1.2 - Single-pulse PPF
  - 1.3 - Multi-pulse PPF
  - 1.4 - Conventional preforming and single-pulse PPF (restrike)
- ▶ Task 2: Microstructure and Mechanical Property Evolution during PPF
  - 2.1 - Characterize constitutive relations
  - 2.2 - Microstructure and texture evolution
  - 2.3 - Post-forming properties of materials subject to PPF
- ▶ Task 3: Numerical Simulation of PPF Process
  - 3.1 - Sheet forming
  - 3.2 - Sheet Die Interaction

Future work will follow original project plan

## 2010 DOE Vehicle Technologies Program Review

# Development of High Strength Superplastic Aluminum Sheet for Automotive Applications

P.I.: Curt Lavender, (509) 372-6770, [curt.lavender@pnl.gov](mailto:curt.lavender@pnl.gov)

Presenter: Mark T. Smith, (509) 375-4478, [mark.smith@pnl.gov](mailto:mark.smith@pnl.gov)

This presentation does not contain proprietary, confidential, or otherwise restricted information

Project ID: LM015





# Project Overview

## Project Timeline:

- ▶ Start - FY08
- ▶ Finish – FY10
- ▶ 85% complete

## Budget:

- ▶ Total project funding:
  - PNNL: \$720k
- ▶ FY08 Funding Received:
  - \$230k
- ▶ FY09 Funding Received:
  - \$345k
- ▶ FY10 Funding Received:
  - \$145k

## Targets

- ▶ The VTP target for weight reduction of the vehicle and its subsystems is 50%.
  - Aluminum has the potential to achieve 45% weight savings vs. conventional steels

## Barriers

- ▶ Barriers to using aluminum in the lightweighting of vehicles:
  - Limited formability at room temperature
  - Superplastic formed (SPF) aluminum has low strengths (150 MPa) that limit weight savings
  - SPF process must be compatible with body shop production process (cycle times, joining, paint bake, etc)

## Partners

- ▶ OEM and Industry participants:
  - Paul Krajewski, General Motors
  - Peter Friedman, Ford
  - Ajit Desai, Chrysler



**Pacific Northwest**  
NATIONAL LABORATORY

*Proudly Operated by Battelle Since 1965*

# Relevance to Technology Gaps:

- ▶ *The objective of this project is to develop a cost-effective superplastic sheet with a post-formed yield strength >250 MPa.*
- ▶ Aluminum has limited formability at room temperature
  - Low work hardening and low strain rate hardening when compared to steels
  - Forming at elevated temperature and specific strain rates enhances strain rate hardening and leads to stable flow at very high strains
- ▶ Aluminum can reduce the mass of an equivalent steel component by up to 45%
  - This has not been possible with SPF because the part exits the die fully annealed
    - Limited to the 5083 alloy with strengths near 150 MPa
  - To fully realize mass savings the strength must be greater than 250 MPa
- ▶ Forming and processing of SPF aluminum components must be compatible with the production process
  - Develop modified SPF alloys that respond to paint bake cycle
- ▶ The project addresses 3 gaps to realize the full potential mass savings from aluminum
  - Low formability
  - Low Strength
  - Compatibility with manufacturing cycle



# Milestones and Gates

## ▶ FY 2008

- Milestone: Identify automotive manufacturing process constraints for high volume SPF aluminum sheet
  - Forming cycle, forming temperature, cooling, paint bake cycle

## ▶ FY 2009

- Gate: Demonstrate ability to meet the strength requirement of  $>250$  MPa for SPF aluminum sheet subjected to simulated manufacturing cycle

## ▶ FY 2010

- Milestone: Produce downselected SPF sheet and demonstrate SPF elongations of 100% in forming time of 15 minutes or less for PNNL “butter tray” (this equates to 5 minute or less for automotive part)

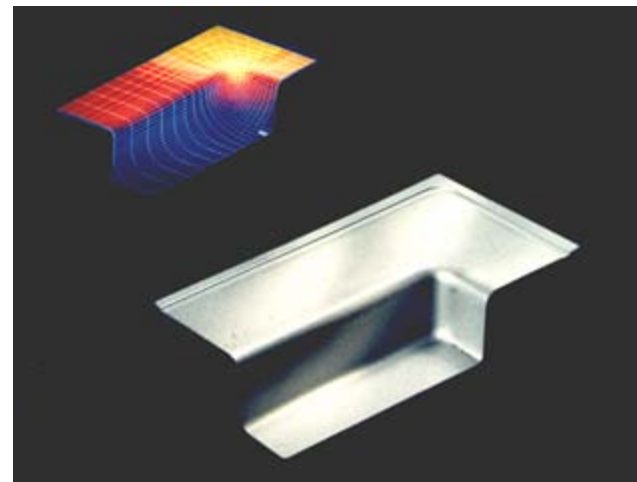
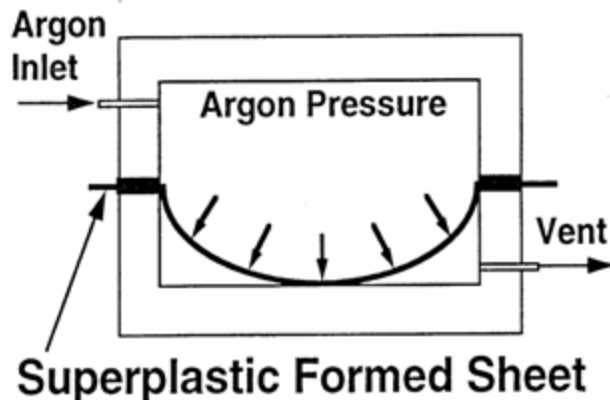

# Approach/Strategy

- ▶ The major SPF process/factory constraints were identified and a series of alloys were made in an attempt to achieve a 250 MPa yield strength.
- ▶ Two “SPF” alloy types were produced
  - Elevated Mg enabling solute drag for stable forming
  - Heavily particle stabilized alloy using a combination of eutectic constituents and dispersoids to produce a fine stable grain size.
- ▶ Two approaches to strengthening were identified based on Cu, Si and Mg precipitates and compositional constraints
- ▶ A single thermomechanical process was applied to the alloys
  - TMP compatible with large-scale aluminum sheet production



# Technical Progress

- ▶ Six key elements of the process were identified and limiting conditions were established:
  - Sheets are heated to SPF temperature
  - SPF Process Sequence (pressure/time cycle)
  - Alloy Composition (limits for Cu, Mg, other alloy additions)
  - Sheet Thermomechanical Process (compatible with aluminum sheet production)
  - Alloy Superplasticity (requires minimum 100% elongation)
  - Post SPF Processing – *Must be hemmable*
  - Final Panel Properties – *250 MPa*

## ▶ “SPF” Process Sequence

- Sheets are heated to SPF temperature in 45 seconds
- Forming less than 500°C; better to focus around 450°C
- Part forming below 5 minutes
- Parts are cooled to 40°C in 4 minutes
- Harden to 250 MPa in paint bake (180°C)



Pacific Northwest  
NATIONAL LABORATORY

Proudly Operated by Battelle Since 1965

# Test Alloy Compositions

- ▶ Literature suggests that it may be possible to meet strength requirements
  - Can strengths be achieved at less than ideal solution heat treat and age?
- ▶ 5 Alloys were prepared
  - Mn held to 1.0 w/o
  - Alloy strengthening by a combination of Solid Solution Strengthening, Mg<sub>2</sub>Si, AlCu Θ, excess Si
    - Oversimplified due to synergistic effects and phases are now being quantified and identified

Alloy	Mg	Si	Cu	Cr	Mg SSS	Mg <sub>2</sub> Si	Θ	Si
5-1	3.5	0	0.4	0.1	X	X	X	
5-2	3.5	0.4	0.4	0.1	X	X	X	
5-3	3.5	0.6	0.4	0.1	X	X	X	
6-1	0.7	1.5	0.2	-		X	X	X
6-2	0.7	1.5	0.4	-		X	X	X

# SPF Process - Hardness Studies

*We know that the panel must exit the cooling fixture with a sufficient solid solution to age to 250 MPa during Paint Bake*  
*Not a press hardening process*

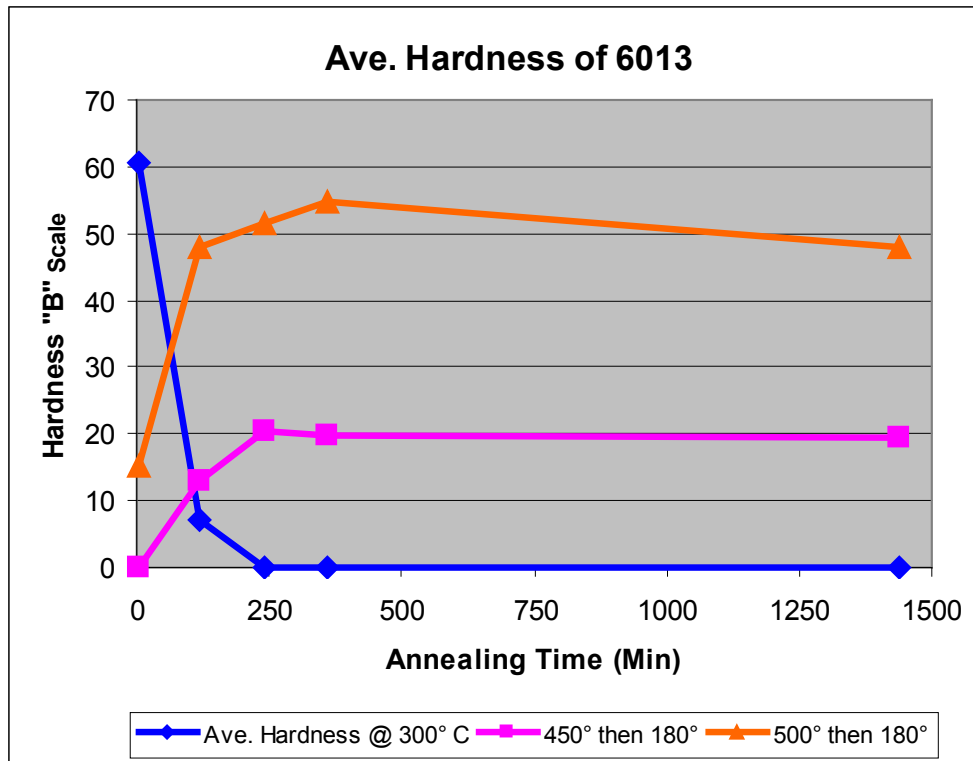

- ▶ Investigate softening kinetics and aging response after heating to potential forming temperatures
- ▶ SPF temperatures expected to be above 300°C with cycle times less than 15 minutes
  - 6013 dead soft after 2 minutes at all temperatures over 300°C
  - 450°C hold temperature yielded a reasonable hardening response but 500°C was better

# Summary

- ▶ **The major SPF process/factory constraints were identified and a series of alloys were made in an attempt to achieve a 250 MPa yield strength.**
- ▶ **Two “SPF” alloy types were produced**
  - Elevated Mg enabling solute drag for stable forming
  - Heavily particle stabilized alloy using a combination of eutectic constituents and dispersoids to produce a fine stable grain size.
- ▶ **Two approaches to strengthening were identified based on Cu, Si and Mg precipitates and compositional constraints**
  - Unlikely that strength goals will be achieved at 450°C forming temperatures with Mg<sub>2</sub>Si
  - Alloys with Cu and excess Si very nearly meet the strength goal with 450°C solution treatment 230MPa w/450°C/PB
    - 240MPa w/450°C/peak age
    - 300MPa w/510°C/peak age
- ▶ **A single thermomechanical process was applied to the alloys**
  - 3.5 w/o Mg alloys exhibited up 300% elongation at 450°C and  $1 \times 10^{-3} \text{ s}^{-1}$
  - 6-X had poor ductility; 100 to 200% at  $1 \times 10^{-3} \text{ s}^{-1}$  at 450°C
  - m-values less than 0.4
  - Optimization of TMP is being initiated focusing on the homogenization/reheat
- ▶ **Phase identification has been initiated and will guide the next alloy iteration**





# Supplemental Slides



**Pacific Northwest**  
NATIONAL LABORATORY

*Proudly Operated by Battelle Since 1965*

# Objective

- ▶ The objective of this project is to develop a cost-effective superplastic sheet with a post-formed yield strength  $>250$  MPa.
  - Outer panel requirement - most challenging
    - Most cost and rate sensitive and must be integrated process within current panel fabrication
    - Diminishing return on strength versus mass savings; 250 MPa would have a large impact on vehicle mass
  - Inner structure requirement
    - Higher value added may allow the use additional processes such as artificial aging
    - No limit on strength

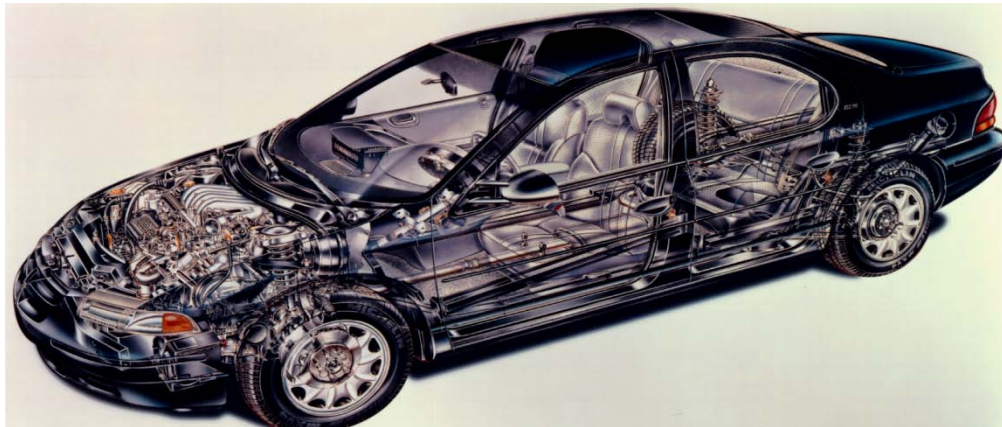

**Pacific Northwest**  
NATIONAL LABORATORY

*Continuously Operated by Battelle Since 1965*

# Agreement History

## ► Project Narrative

- PNNL has extensive history in SPF and aluminum metallurgy
  - Led to the “Quick Plastic Forming Process” used at GM
- Similar activity was funded with PACCAR for aerodynamic styling and lightweighting of the Cab structure
  - HSWR project

## ► Funding

- FY2008, \$230K; FY2009, \$345; FY2010, \$145K



# Prior High Strength SPF Effort

- ▶ PNNL worked with 6013 for DOE Heavy Vehicle Materials Technology
  - Successful with a Cu precipitate (1.0% copper)
- ▶ Need to demonstrate with **Cu content 0.4% or less** at faster SPF rates
  - Recent corrosion findings
  - Changed the course of the project



Quench condition from forming temperature	Yield Strength, MPa	UTS, MPa	Elongation, %
Water	320	402	18
Forced air	300	381	15
Air cooled	286	360	12

# “SPF” Process Constraints

## ▶ “SPF” Process

- Sheets are heated to SPF temperature in 45 seconds
- Forming less than 500°C; better to focus around 450°C
- Part forming below 5 minutes
- Parts are cooled to 40°C in 4 minutes
- Must exit the SPF process soft enough for post processing (i.e. hemming)
- Harden to 250 MPa in paint bake (180°C for less than 2 hours)

## ▶ This is not a recipe for an ideal high strength aluminum alloy

- Aluminum alloys like rapid up quench, solution temperatures above 515°C, solution times of 15 minutes (minimum), fast transfer to a circulating water quench, long age times



# Challenge

## ▶ Summary

- Low solution treatment temperature
- No Zn, minimal Cu
- Slow cooling rate
- Short aging time
- *Time to find a different project!*

## ▶ A project that was started as development of superplasticity in modified 6111/6013 alloys shifted toward optimizing strengthening mechanisms around a non-ideal thermal cycle

- Investigating alloying for 2 purposes:
  - “Superplasticity”
  - Strengthening
    - ◆ Primarily through maximum allowed Cu and Si and Mg additions



**Pacific Northwest**  
NATIONAL LABORATORY

# Alloy Composition – Two Options for SPF

- ▶ High Rate “SPF” due to a relatively fine equiaxed grain size and solute drag
  - Modify or select a Mg containing alloy over 3 weight percent
  - Lower “SPF” temperature – combined fine-grained and solute drag
- ▶ High Rate “SPF” due to fine grain size
  - Modify or select a 6XXX alloy
  - Raise Cu to an estimated threshold
  - Raise Eutectic Constituent formers to levels that produce fine grain sizes i.e. less than 10 μm
  - Higher SPF temperature – more classic fine grained SPF

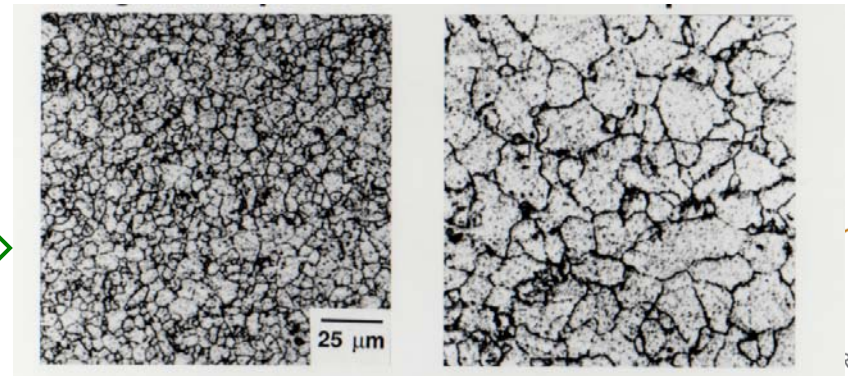
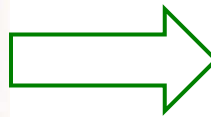
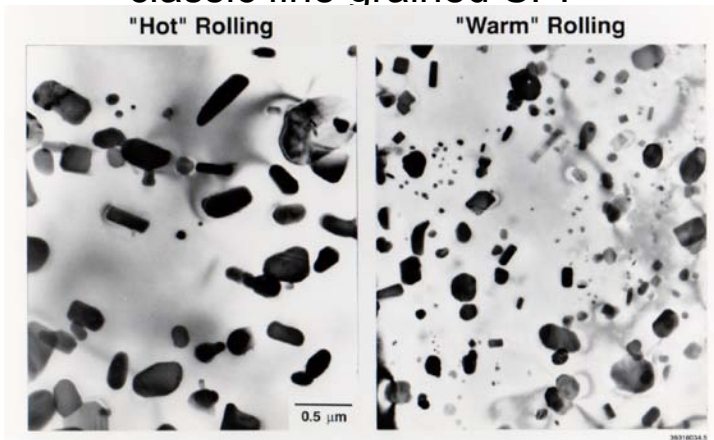
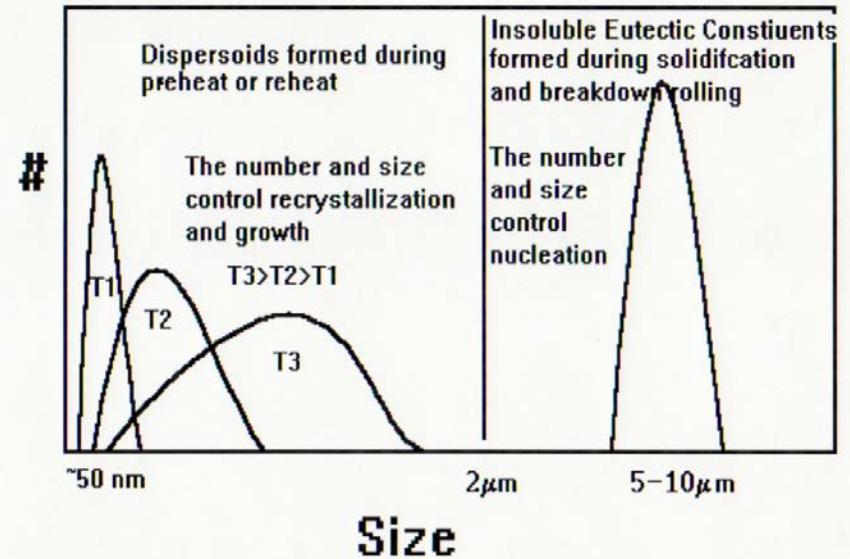

# Effect of Excess Si on YS of Al-Mg-Si Alloys Aged at 180°C (Gupta et al. 2001)

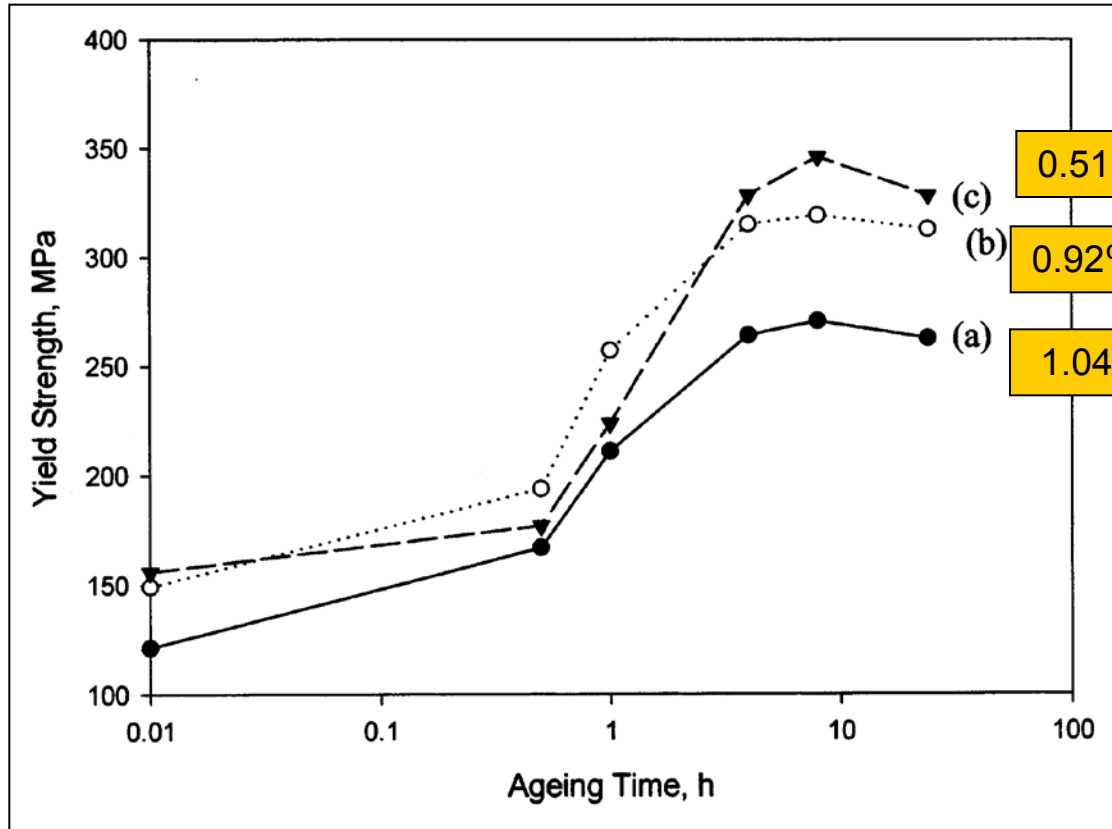

0.51% Excess Si, 1.26% Mg<sub>2</sub>Si

0.92% Excess Si, 0.95% Mg<sub>2</sub>Si

1.04% Excess Si, 0.63% Mg<sub>2</sub>Si

- ▶ Hardening Rate function of Mg/Si ratio and wt% Mg<sub>2</sub>Si
- ▶ 1 hour aging at 180°C gives 250 MPa yield strength
- ▶ Mg additions to excess Si reduce free Si precipitation, increases β'' size and density

Effect of Mg addition on the aging behavior of Al-Mg-Si alloys containing excess Si. (a) 0.4 wt.% Mg, 1.32 wt.% Si; (b) 0.6 wt.% Mg, 1.32 wt.% Si; (c) 0.8 wt.% Mg, 1.02 wt.% Si. All alloys contain 0.25% Fe.



Pacific Northwest  
NATIONAL LABORATORY

Proudly Operated by Battelle Since 1965



# Addition of Cu and Effect on Precipitation Kinetics (Gaber et al., 2007)

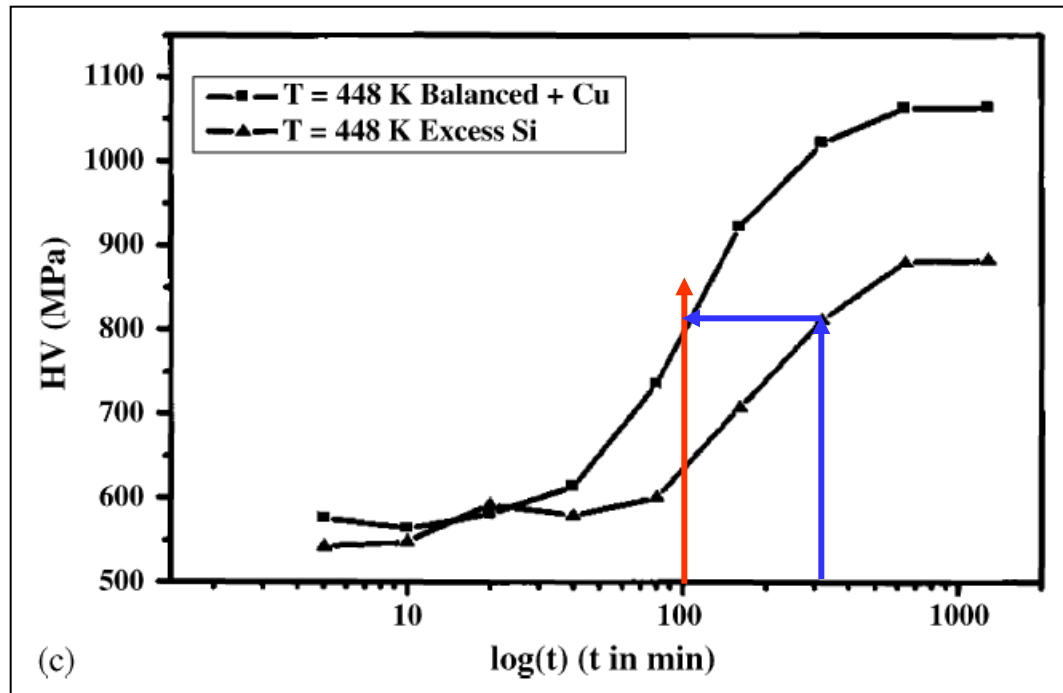

- ▶ At 100 minutes, little hardness increase in Excess Si alloy
- ▶ 35% increase by adding Cu to the balanced alloy
- ▶ Time to achieve comparable hardness is appreciably lowered switching from Excess Si alloy to Bal Alloy + Cu
- ▶ Cu is a potent strengthening addition
  - Cu enhances the clustering process, forms Mg-Si-Cu clusters
  - Addition of Cu promotes additional Q' and  $\beta'$  precipitation

- ▶ Excess Si alloy: Al-0.71% Mg-0.76% Si
  - 1.12 wt.%  $Mg_2Si$ , 0.35 wt.% Excess Si
- ▶ Bal Alloy + Cu: Al-0.68% Mg-0.45% Si
  - 1.07 wt.%  $Mg_2Si$ , 0.06 wt.% Excess Si



Pacific Northwest  
NATIONAL LABORATORY

Proudly Operated by Battelle Since 1965

# TMP for Initial SPF Coupon Work

- ▶ Book mold casting at 75mm
- ▶ Re-heat (homogenization)
  - 510°C for 10 hrs for this presentation
- ▶ Hot forge to 18mm (at Re-heat T)
  - Hardness and tension testing at 18mm
- ▶ Cold roll to 8mm
- ▶ Anneal 400°C
- ▶ Cold roll to 2mm
  - Hot tensio



Pacific Northwest  
NATIONAL LABORATORY

Proudly Operated by Battelle Since 1965

# Hardness and Tensile Test Results – 5-X

- ▶ Solution heat treat by air cool at 6mm round
- ▶ Minimal (No) hardening response at 400 or 450°C
- ▶ Moderate hardening at 510°C
- ▶ Unlikely we will be able to get enough Si in solution at low “SPF” temperatures
- ▶ Tensile tests were performed at *peak age*
  - 450°C – yield strengths were approx. 120 MPa
  - 510°C – yield strengths were approx. 150 MPa
- ▶ Slight dependence of strength and hardness on Si content when heat treated at 510°C

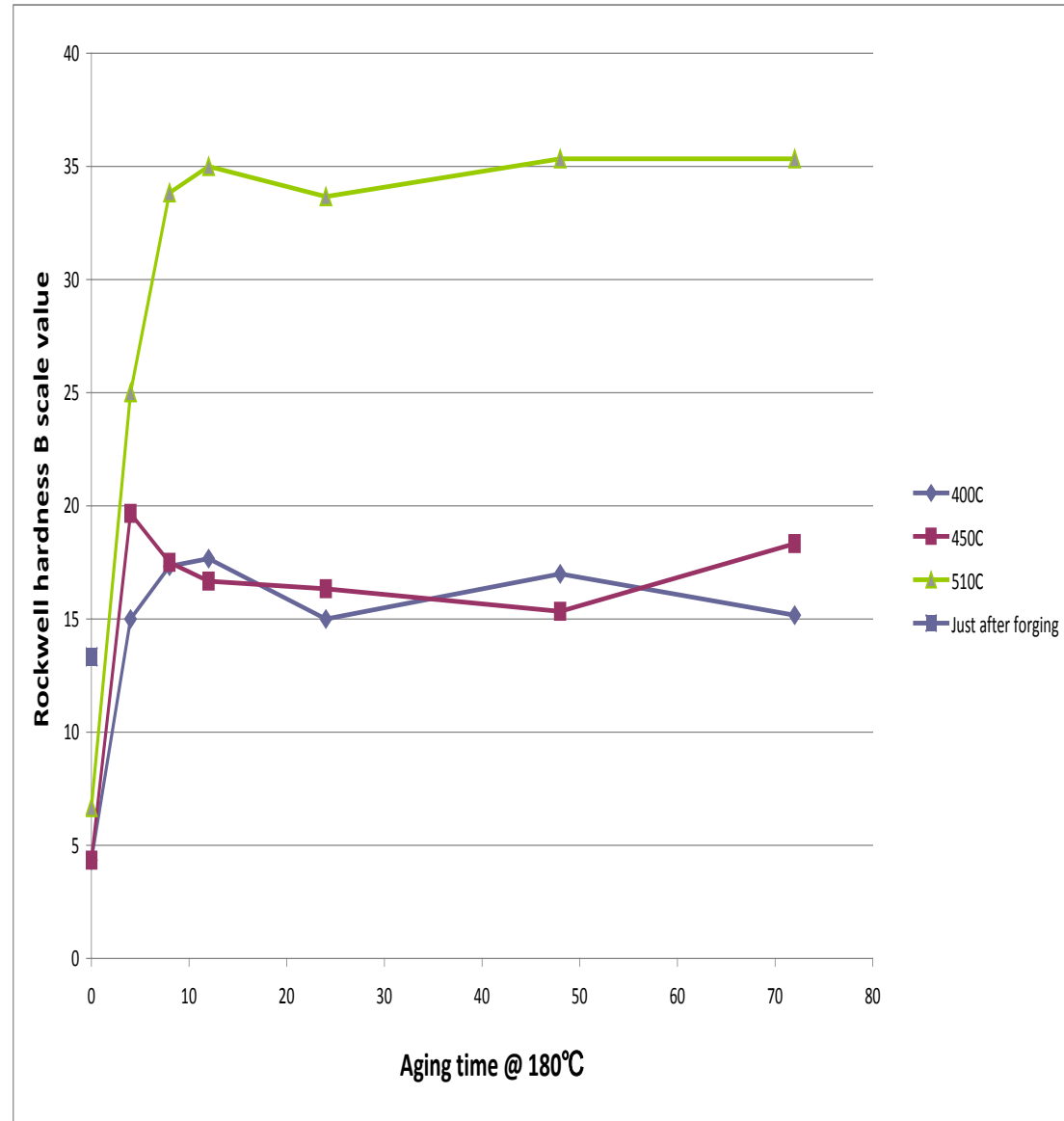

# Hardness Results – 6-X

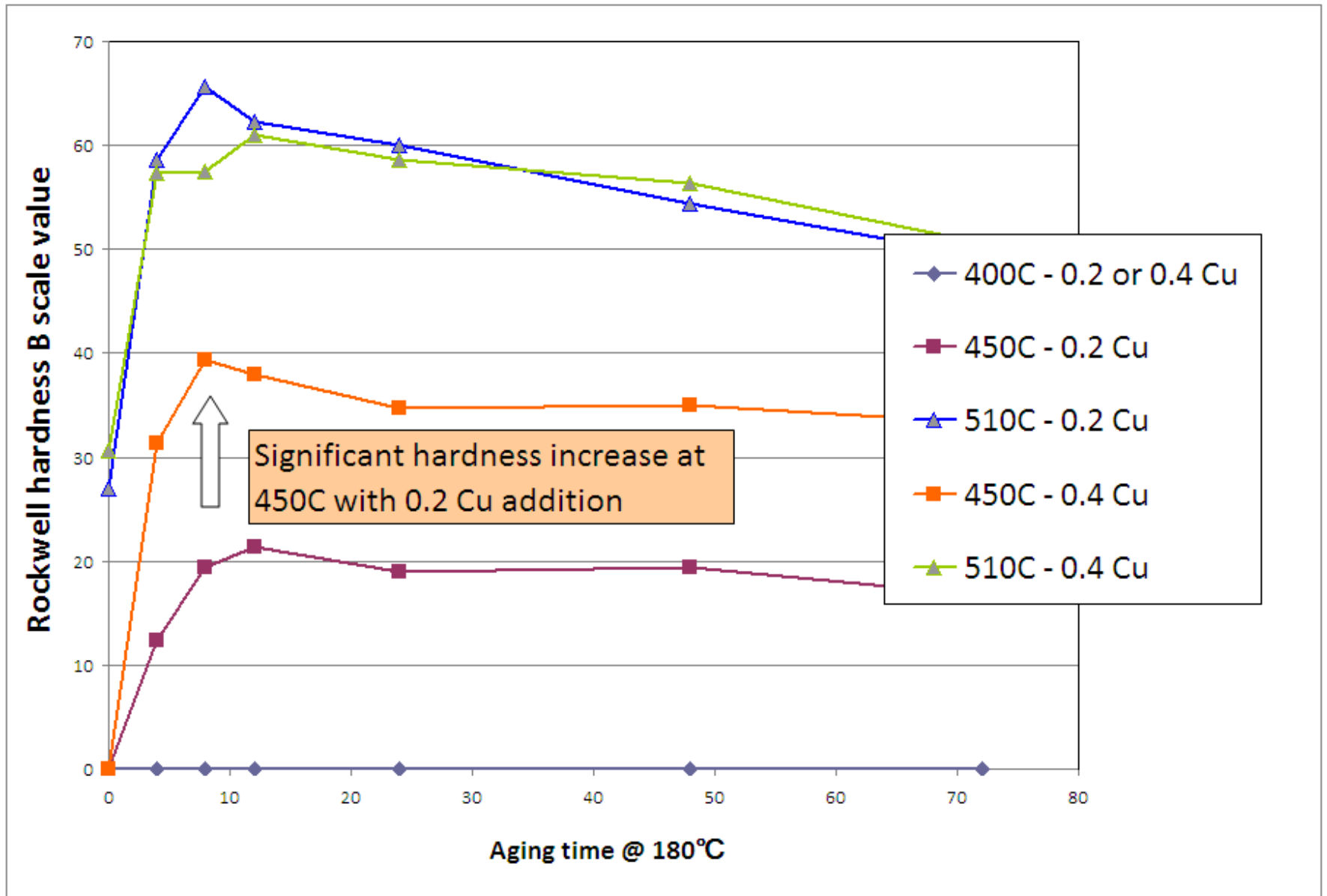

# Tensile Test Results for 6-X

- ▶ Effect of solution treatment temperature
  - 510°C no discernable difference in hardness or strength for Cu
    - YS = 300MPa, UTS = 330MPa
  - 450°C difference in hardness and strength with Cu
    - 0.2 Cu YS = 210 MPa, UTS = 260 MPa
    - 0.4 Cu YS = 240 MPa, UTS = 275 MPa
  - 400°C no hardness response
  
- ▶ Paint Bake – very short sequence for aging
  - 0.2 Cu alloy – YS = 180MPa, UTS = 225MPa
  - 0.4 Cu alloy – YS = 230MPa, UTS = 280MPa
  
- ▶ Phases have not been identified or optimized the results are encouraging



# Superplastic Tension Testing – ASTM E2448

- ▶ Tried a single TMP condition
  - May not be optimum reheat – important for fine grain size
  - Forging to 18mm did not redistribute ECs as desired
  - 75% cold reduction from mill anneal produced  $m=0.5$  and 300% in 6013

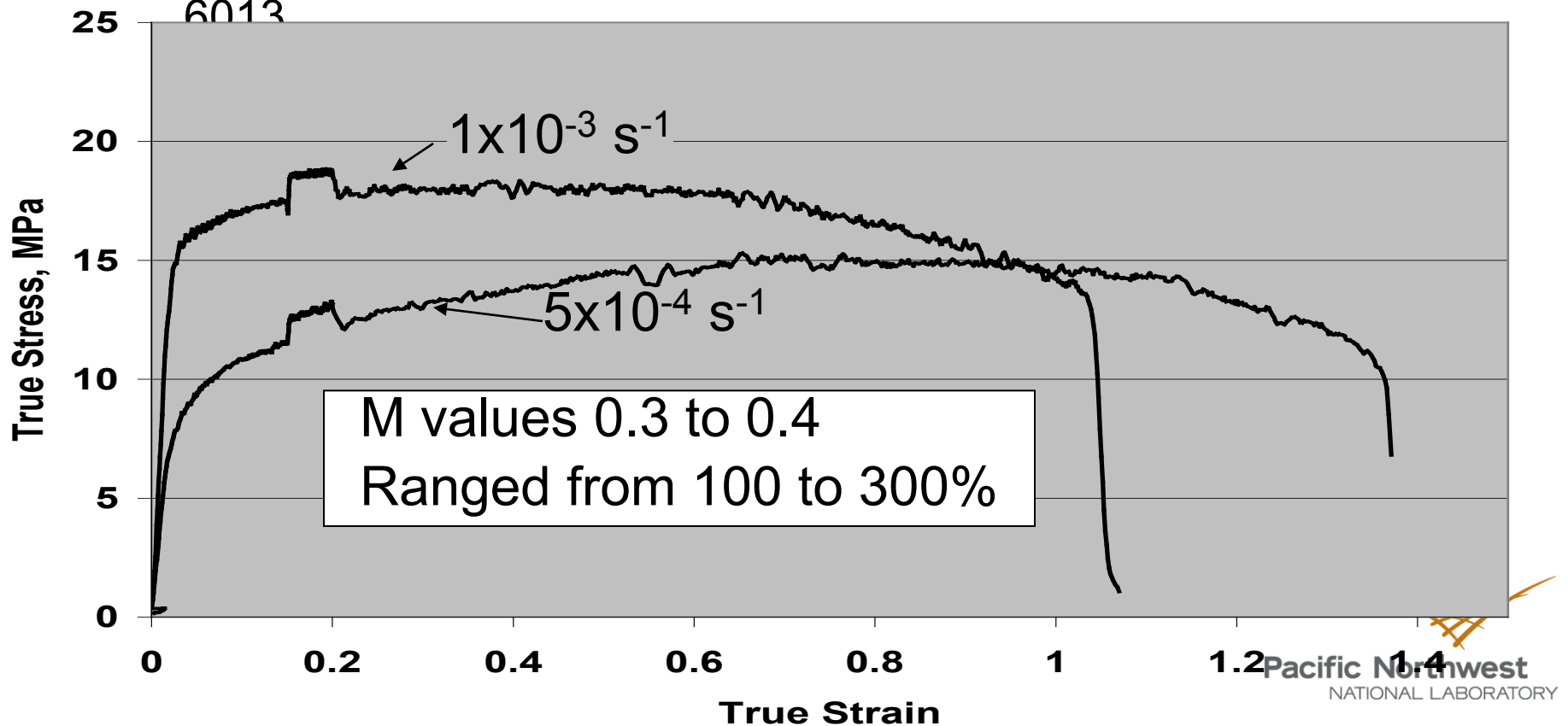

# Microstructure

Characterization and second iteration is needed

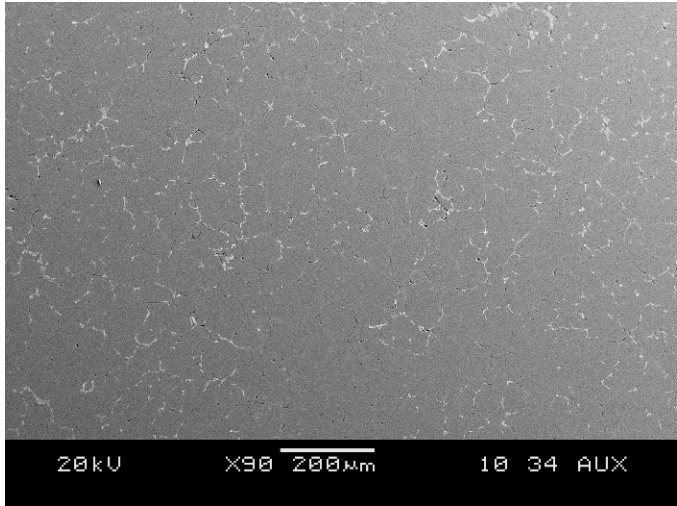

As Cast

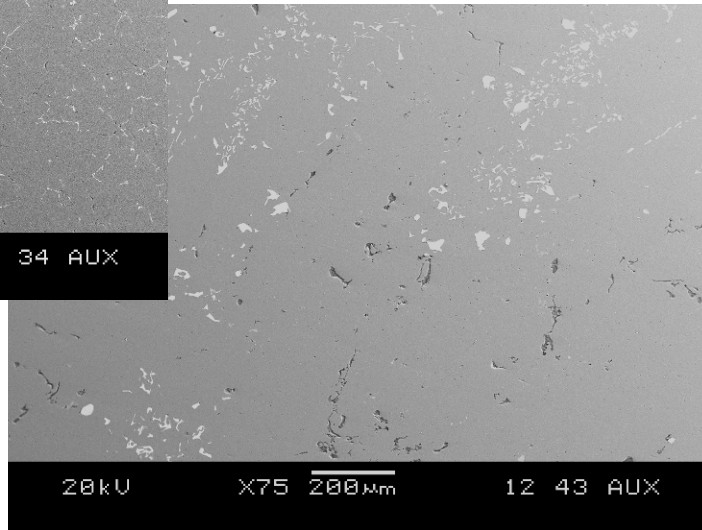

As Forged

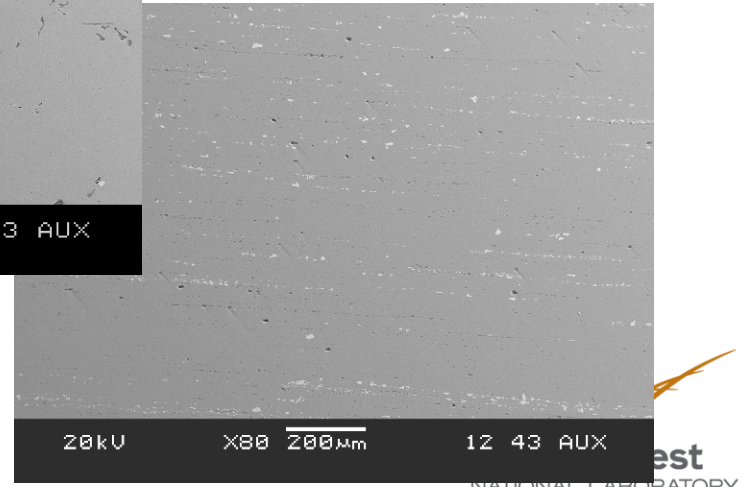

As Rolled

est  
NATIONAL LABORATORY

Proudly Operated by Battelle Since 1965

# Production Readiness/Business Case

- ▶ The primary deliverable from the project will be an alloy system and microstructure that produces the desired properties
  - This system will then be transferred to an aluminum mill for production, similar approach to the development of the 5083 used today.
- ▶ Material Supplier involvement has been difficult
  - Kaiser, Alcoa, Corus have expressed willingness to produce sheet of sufficient size to validate the process but have not yet expressed interest in participating in the development program
- ▶ Business case may be a little early given that we have determined a range of compositions but not a thermomechanical process to produce sheet
  - Alloy compositions and processes have been focused around ingot production using DC casting
  - One point to make is that we have chosen low cost compositions



*Project No: 49095, Agreement No: 13055*

# Friction Stir Spot Welding of Advanced High Strength Steels

Yuri Hovanski, [yuri.hovanski@pnl.gov](mailto:yuri.hovanski@pnl.gov)

and Glenn Grant

Pacific Northwest National Laboratory

Michael Santella

Oak Ridge National Laboratory

Presenter: Mark T. Smith, (509) 375-4478, [mark.smith@pnl.gov](mailto:mark.smith@pnl.gov)

This presentation does not contain proprietary,  
confidential, or otherwise restricted information

Project ID: LM015



*Proudly Operated by Battelle Since 1965*

# Project Overview

## Project Timeline

- ▶ Start: 2010
- ▶ Finish: 2012
- ▶ 10% complete

## Budget

- ▶ Total project funding
  - DOE – \$1.0M
  - 50/50 Split with ORNL/PNNL
- ▶ FY10 Funding - \$500K
- ▶ FY11 Funding - \$500K

## Technology Gaps/Barriers

- ▶ FSSW of AHSS has only been demonstrated in limited capacity
- ▶ Tool life and Deployment issues have yet to be answered
- ▶ Many AHSS alloys and stack up geometries are problematic for RSW

## Partners

- ▶ USCAR Joining team
  - GM, Ford, Chrysler
- ▶ Commercial automotive sheet vendors
  - ▶ Arcelor Mittal, GeStamp-HardTech & US-Steel
- ▶ Tool Manufacturers / Material Providers
  - ▶ MegaStir & Ceredyne
- ▶ Machine Builders (TBD)
- ▶ Universities
  - ▶ BYU



**Pacific Northwest**  
NATIONAL LABORATORY

# Project Motivation

- ▶ Future B-I-W will be hybrid of many materials. Some of those, especially Advanced High Strength Steels, are presenting a challenge to conventional joining methodologies.
- ▶ FSSW may enable implementation of additional alloy combinations and stack-ups that providing additional weight and cost savings

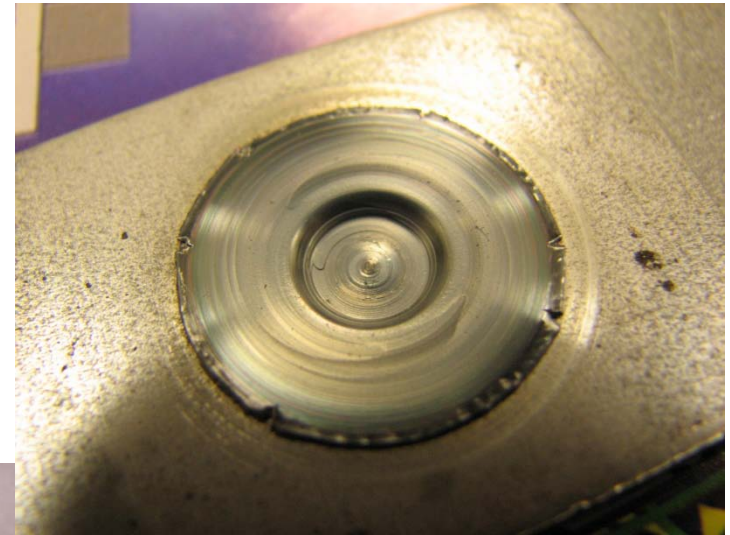
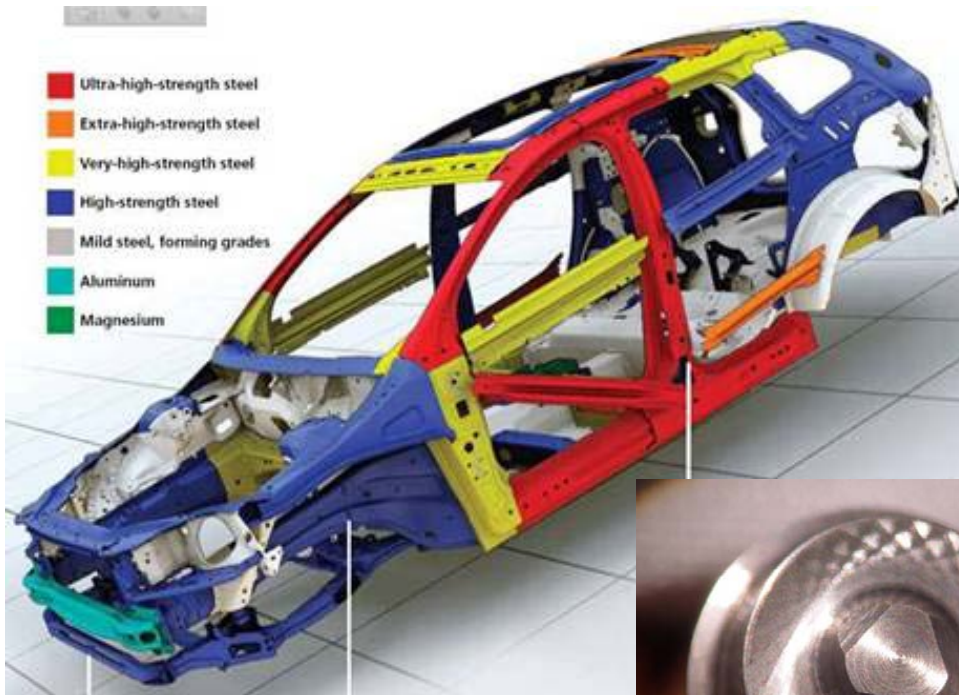

# Project Goal and Objectives

Demonstrate that friction stir spot welding (FSSW) is an acceptable, cost effective alternative for AHSS that are difficult to resistance spot weld (RSW) and that FSSW may enable down-gaging of sheet thickness through unequal/dissimilar material stacks

## Objectives:

1. Enable joining of AHSS alloys in unequal metal thickness stacks (which respond poorly to RSW techniques)
2. Develop more comprehensive information about mechanical properties including T-peel behavior, cross-tension strength, fatigue strength, impact behavior, of AHSS joints produced via FSSW.
3. Determine comparative information related to stir tool durability, weld quality and supply chain
4. Identify remaining issues preventing high production deployment

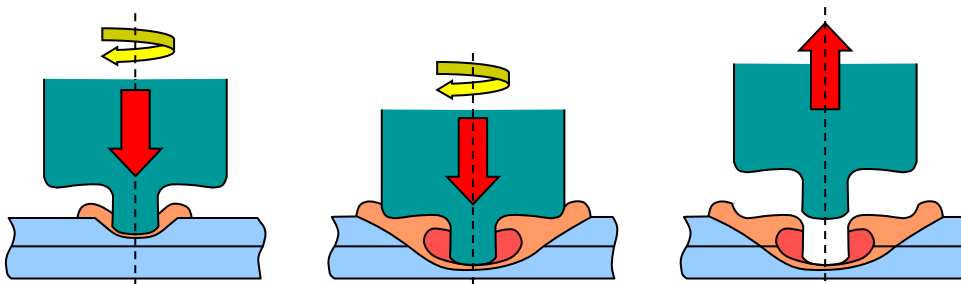

# Project Milestones

<u>DOE Significance</u>	Month/Year	Milestone or Go/No-Go Decision
Alloy specific Feasibility	Sept. 2010 <i>Initial Decision Gate</i>	<b>Achieve Structural Joints with FSSWs in AHSS that are problematic to RSW</b> Achieve the minimum tensile strength criteria specified in AWS D8.1 in down selected alloys (standard is material/thickness/property/size specific)
High Volume Applicability	Sept. 2011 <i>Final Decision Gate</i>	<b>Demonstrate Tool Life of Probable Materials</b> Determine the joining cost associated with FSSW based on wear studies up to 5000 welds/tool filling gaps in the comparative cost model.
Deployable Technology	July 2012 Final Milestone	<b>Complete Evaluation of Process Deployability</b> Determine compatibility with current machinery and manufacturing techniques including identifying possible “show-stopper” issues related to direct technology deployment



Pacific Northwest  
NATIONAL LABORATORY

Proudly Operated by Battelle Since 1965

# Current Progress and Scheduled Work

- ✓ Completed Initial Evaluation of FSSW of AHSS (FY06-FY09)
- ✓ Continuing Task 1.1 and 1.2 for completion in FY10

	Fiscal Year 2009				Fiscal Year 2010				Fiscal Year 2011				Fiscal Year 2012			
Quarter	Q 1	Q 2	Q 3	Q 4	Q 1	Q 2	Q 3	Q 4	Q 1	Q 2	Q 3	Q 4	Q 1	Q 2	Q 3	Q 4
<b>Task 1: FSSW Process Development for TRIP steels</b>																
1.1 Material Selection					■	■										
1.2 FSSW property/process relationships for TRIP steel						■	■	■								
<b>Decision Gate</b>								■								
<b>Task 2: Characterization of Joint Interface</b>																
2.1 Joint Characterization						■	■	■	■	■	■	■				
2.2 Zinc effects in weld								■	■	■	■	■				
<b>Task 3: Evaluation of Tool Materials for FSSW</b>																
3.1 Determine test and tool									■							
3.2 Stir tool durability tests									■	■	■	■				
<b>Decision Gate</b>												■				
<b>Task 4: Assessment of Deployment Issues for FSSW</b>																
4.1 Testing to compare properties of welds made by FSSW and RSW									■	■	■	■				
4.2 Cost Model to compare FSSW with RSW											■	■	■	■		
4.3 Assess compatibility with existing robots and other assembly equipment													■	■	■	■

Completed Work

Near Term Gate

Dependent on Success of Preliminary Gate

Completed work

Completed Decision Gate

Future Decision Gate

Future Work



# Technical Approach:

- ▶ Task 1: FSSW process development for AHSS with problematic RSW performance
  - Initial Decision Gate: Achieve Structural Joints with FSSWs in AHSS that are problematic to RSW
- ▶ Task 2: Characterization of the Joint Interface
- ▶ Task 3: Evaluation of tool materials for FSSW
  - Final Decision Gate: Demonstrate Tool Life of Probable Materials
- ▶ Task 4: Assessment of Deployment Issues for FSSW of AHSS



# Task 1 – FSSW Process Development for AHSS with Problematic RSW Performance

- ▶ Using previous work as a guide, rapidly develop tooling and process parameters for unconventional multi-sheet stacks and problematic alloy/combinations
- ▶ Tool Materials Selected for Evaluation
  - Poly crystalline cubic boron nitride
  - Silicon nitride
- ▶ Material Selection Based on Upcoming OEM Priorities
  - Includes dissimilar AHS steels, AHSS to mild steel, and dissimilar thickness of the same.
    - TRIP 980, HSBS, DP980
    - 0.5 mm to 2.0 mm thickness

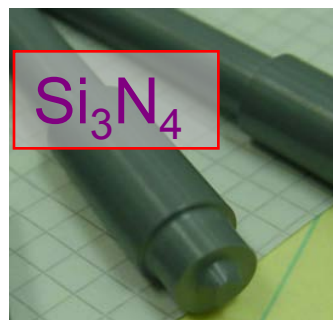



# Task 2 – Characterization of the Joint Interface

- ▶ Characterize microstructure and joint properties
  - Lap shear, T-peel, cross-tension, fatigue, impact behavior, etc.
- ▶ Determine the effect of Zinc Coatings
  - Liquid Metal Embrittlement (LME) on weld surface?
  - Characterize the effects of zinc incorporation into FSSWs on mechanical properties and fracture behavior
- ▶ Develop a fundamental understanding of the effect of coatings on weld metal microstructure and mechanical properties

PCBN tool

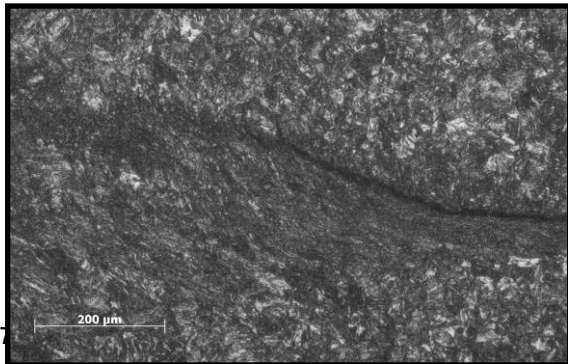

Si<sub>3</sub>N<sub>4</sub> tool

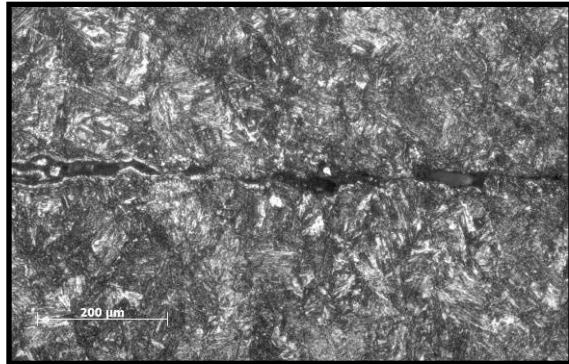

# Task 3 – Evaluation of Tool Materials for FSSW of AHSS

- ▶ Evaluate candidate tool materials in selected alloy/stack combinations
  - Durability testing to compare the overall price based on production costs and cycles to failure

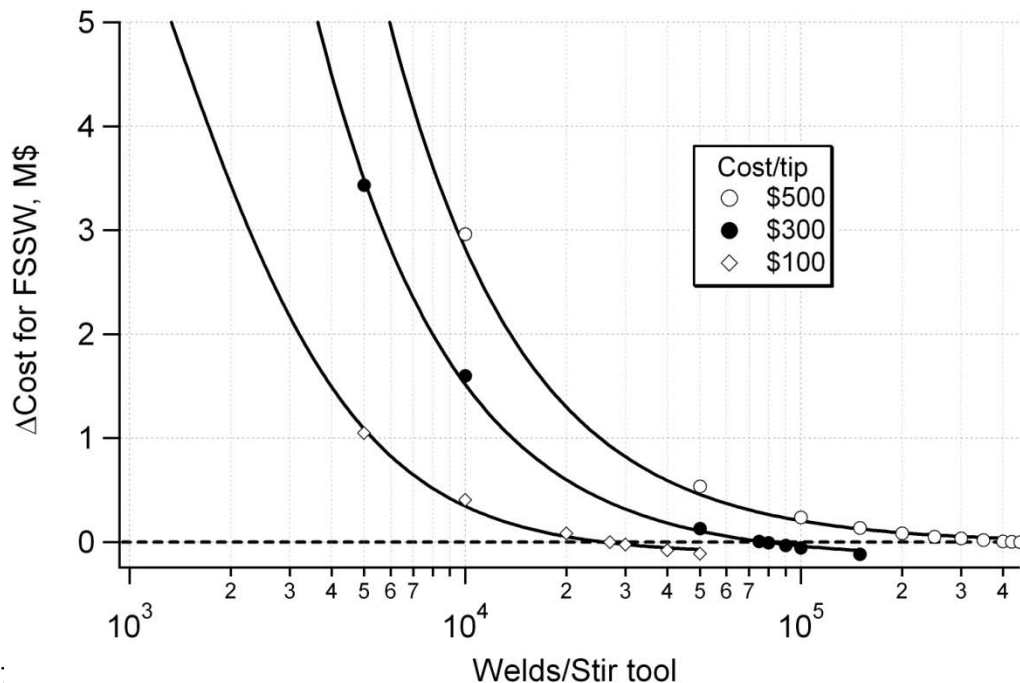

*From Previous Work:  
FSSW tools costing \$100  
would need to survive 26,000  
welds for cost parity with  
Resistance Spot Welding*

# Task 4 – Assessment of Deployment Issues for FSSW of AHSS

- ▶ Compare FSSW to RSW through joint testing
- ▶ Evaluate FSSW process costs with tool life cycle data included against RSW baseline
- ▶ Validate FSSW parameter needs with existing industrial technology (robots, pedestal stations, etc.)
- ▶ Identify and evaluate remaining critical needs for industry embodiment of FSSW of AHSS



Robotic Friction Stir Joining

Courtesy of Kawasaki Robotics



**Pacific Northwest**  
NATIONAL LABORATORY

*Proudly Operated by Battelle Since 1965*

# Summary and Status

- ▶ Compiled an initial AHSS selection based on near term OEM needs and problematic geometries
  - Final material selection & stack configuration is underway
- ▶ Tool Material Wear Testing
  - Subcontract for wear testing has been issued
  - Validation of process parameter mobility is ongoing
    - Process parameters for bare materials were verified
    - Coated materials are currently being evaluated
- ▶ Low cost Tooling Development
  - Injection molding die design underway
    - To be built for low cost tool production using Silicon Nitride
    - Ceredyne to provide multi-tip die for low cost Silicon Nitride tool production