

# Advanced Envelope Research for Factory Built Housing, Phase 3—Whole- House Prototyping

E. Levy, M. Mullens, and P. Rath  
*Advanced Residential Integrated Energy  
Solutions (ARIES) Collaborative*

April 2014

## NOTICE

This report was prepared as an account of work sponsored by an agency of the United States government. Neither the United States government nor any agency thereof, nor any of their employees, subcontractors, or affiliated partners makes any warranty, express or implied, or assumes any legal liability or responsibility for the accuracy, completeness, or usefulness of any information, apparatus, product, or process disclosed, or represents that its use would not infringe privately owned rights. Reference herein to any specific commercial product, process, or service by trade name, trademark, manufacturer, or otherwise does not necessarily constitute or imply its endorsement, recommendation, or favoring by the United States government or any agency thereof. The views and opinions of authors expressed herein do not necessarily state or reflect those of the United States government or any agency thereof.

Available electronically at <http://www.osti.gov/scitech>

Available for a processing fee to U.S. Department of Energy  
and its contractors, in paper, from:

U.S. Department of Energy  
Office of Scientific and Technical Information  
P.O. Box 62  
Oak Ridge, TN 37831-0062  
phone: 865.576.8401  
fax: 865.576.5728

email: <mailto:reports@adonis.osti.gov>

Available for sale to the public, in paper, from:

U.S. Department of Commerce  
National Technical Information Service  
5285 Port Royal Road  
Springfield, VA 22161  
phone: 800.553.6847  
fax: 703.605.6900

email: [orders@ntis.fedworld.gov](mailto:orders@ntis.fedworld.gov)

online ordering: <http://www.ntis.gov/ordering.htm>



Printed on paper containing at least 50% wastepaper, including 20% postconsumer waste

## **Advanced Envelope Research for Factory Built Housing Phase 3—Whole-House Prototyping**

Prepared for:

The National Renewable Energy Laboratory

On behalf of the U.S. Department of Energy's Building America Program

Office of Energy Efficiency and Renewable Energy

15013 Denver West Parkway

Golden, CO 80401

NREL Contract No. DE-AC36-08GO28308

Prepared by:

E. Levy, M. Mullens, and P. Rath

ARIES Collaborative

The Levy Partnership, Inc.

1776 Broadway, Suite 2205

New York, NY 10019

NREL Technical Monitor: Michael Gestwick

Prepared under Subcontract No. KNDJ-0-40347-04

April 2014

**[This page left blank]**

# Contents

<b>List of Figures</b> .....	<b>vii</b>
<b>List of Tables</b> .....	<b>vii</b>
<b>Definitions</b> .....	<b>viii</b>
<b>Acknowledgments</b> .....	<b>ix</b>
<b>Executive Summary</b> .....	<b>x</b>
<b>1 Introduction</b> .....	<b>1</b>
1.1 Background .....	1
1.2 Project Scope .....	2
1.3 Research Partners .....	3
1.3.1 Steering Committee .....	3
1.3.2 Insulation Manufacturers .....	4
1.3.3 ARIES Technical Team .....	4
1.4 Research Process .....	4
1.5 Research Questions .....	5
<b>2 Mathematical and Modeling Methods</b> .....	<b>6</b>
2.1 Cost-Benefit Analysis .....	6
<b>3 Research/Experimental Methods</b> .....	<b>7</b>
3.1 Wall Panel Mockup Demonstration .....	7
3.1.1 Mockup Specifications .....	7
3.1.2 Testing Apparatus .....	7
3.1.3 Assessment Criteria .....	8
3.2 Whole-House Prototyping .....	9
3.2.1 Prototype Home Drawings and Specifications .....	9
3.2.2 In-Plant Testing Criteria .....	11
3.2.3 On-Site Inspection Criteria .....	11
<b>4 Results: Phase 3—Design Development and Prototyping (Continued)</b> .....	<b>12</b>
4.1 Overview of Phase 3 .....	12
4.2 Advanced Design-Development .....	12
4.2.1 Design Specifications .....	12
4.2.2 Construction Drawings .....	14
4.2.3 Attachment Methods .....	17
4.3 Code Compliance Evaluation .....	17
4.4 Wall Mockup and Whole-House Prototyping .....	18
4.4.1 Location and Participants .....	18
4.4.2 Wall Mockup Observation and Evaluation .....	18
4.4.3 Whole-House Prototyping Observation and Evaluation .....	21
4.4.4 On-Site Inspection Results .....	25
4.5 Manufacturing Process Analysis .....	26

4.5.1	Baseline Process.....	26
4.5.2	Test Process .....	30
4.6	Cost Benefit Analysis .....	38
<b>5</b>	<b>Discussion.....</b>	<b>42</b>
5.1	Whole-Building System Integration .....	42
5.2	Identification of Barriers to Market Acceptance .....	43
<b>6</b>	<b>Conclusion and Next Steps .....</b>	<b>44</b>
<b>7</b>	<b>References .....</b>	<b>46</b>
	<b>Appendix.....</b>	<b>47</b>

## List of Figures

Figure 1. Plan view of the mockup frame panel.....	7
Figure 2. Front elevation (right) and side elevation (left) of the mockup frame panel .....	8
Figure 3. Plan of the full-scale prototype home.....	9
Figure 4. Elevations of the full-scale prototype home .....	10
Figure 5. Typical cross-section .....	10
Figure 6. Stud wall with CI, Design 1 (climate zone 5) .....	13
Figure 7. Stud wall with CI, Design 2 (climate zones 6, 7, and 8).....	13
Figure 8. Plan view of wall detail .....	14
Figure 9. Detail at top plate (gable wall section).....	15
Figure 10. Detail at roof-wall connection (side wall section).....	15
Figure 11. Detail at foundation .....	16
Figure 12. Detail at window sill .....	16
Figure 13. Interior wall crack on the test home.....	25
Figure 14. No damage to the exterior walls of the test home: end wall .....	25
Figure 15. No damage to the exterior walls of the test home: side wall .....	25
Figure 16. Karsten plant layout .....	27
Figure 17. Trimming a CI board .....	31
Figure 18. Installing and tacking foam boards.....	32
Figure 19. Installing CI at the gable.....	33
Figure 20. Siding installation .....	33
Figure 21. Cutting out a window opening with a circular saw .....	34

*Unless otherwise noted, all figures were created by the ARIES team.*

## List of Tables

Table 1. Mockup Panel Specifications .....	7
Table 2. Physical Properties of Foamular 250 XPS .....	13
Table 3. Product Tests and Approvals on Foamular 250.....	14
Table 4. Fastener Specifications .....	17
Table 5. Process Time Estimates for Select Baseline Activities .....	29
Table 6. Process Time Estimates for Selected Test Activities .....	36
Table 7. Marginal Labor for the Test Home (Two Floors) .....	36
Table 8. Cost Analysis of Wall Options .....	39
Table 9. Marginal Energy Savings Compared With Base Case (\$/Year) .....	41
Table 10. LCC Analysis, 30-Year Time Horizon .....	41
Table 11. Equipment and Material Needs .....	47

*Unless otherwise noted, all tables were created by the ARIES team.*

## Definitions

BEopt <sup>®</sup>	Building Energy Optimization software
CI	Continuous insulation
EPS	Expanded polystyrene
XPS	Extruded polystyrene
HUD	U.S. Department of Housing and Urban Development
IECC	International Energy Conservation Code
OSB	Oriented strand board
RD&D	Research, design, and development
SIP	Structural insulated panel



## **Acknowledgments**

ARIES Collaborative would like to recognize the support of the U.S. Department of Energy's Building America Program and Michael Gestwick of NREL for technical guidance. We also would like to acknowledge the research direction provided by the factory built housing industry represented by leading home manufacturers. We were fortunate to have many of the nation's leading manufacturers advising and guiding the effort and seeking ways to affordably improve energy performance to benefit all homebuyers.

## Executive Summary

The Advanced Envelope Research effort will provide factory homebuilders with high performance, cost-effective alternative envelope designs. In the near term, these technologies will play a central role in meeting more stringent energy code requirements. For manufactured homes, the thermal requirements, last updated by statute in 1994, will move up to the more rigorous International Energy Conservation Code (IECC) 2012 levels soon, the requirements of which are on par with those for site-built and modular housing. This places added importance on identifying envelope technologies that the industry can implement in the near term. Specifically, the primary goal of this research is to develop wall designs that meet the thermal requirements based on 2012 IECC standards. Given the affordable nature of manufactured homes, impact on first cost is a major consideration in developing the new envelope technologies.<sup>1</sup>

This work is part of a multiphase effort. Phase 1 identified seven envelope technologies and provided a preliminary assessment of three selected methods for building high performance wall systems. Phase 2 focused on developing viable product designs and manufacturing strategies, addressing code and structural issues, and analyzing the costs of the three selected options. An industry advisory committee helped critique and select the most viable solution, a process that narrowed the research focus to perfecting a stud wall design with exterior continuous insulation (CI). Phase 3, completed in two stages, continued the design development effort and explored and evaluated a range of methods for applying CI to factory built homes. The scope also included material selection, manufacturing and cost analysis, and prototyping and testing.

During this phase, a home was built with CI, evaluated, and placed in service. The experience of building a mockup wall section with CI and then constructing online a prototype home helped address important concerns about how best to integrate the material into the production process. First steps were taken toward finding least expensive approaches for incorporating CI in standard factory building practices, and a preliminary assessment suggested that even at this early stage the technology is attractive when viewed from a life cycle cost perspective. Phase 4, started in late 2013, includes the construction of additional prototypes and a side-by-side test to evaluate the impact on energy use of the new wall system and other performance-related attributes.

---

<sup>1</sup> First cost impacts are more meaningful for buyers of modestly priced homes and therefore decisions about efficiency measures must be made in light of both impact on cost and cost effectiveness.

# 1 Introduction

The Advanced Envelope Research project seeks to improve the energy performance of new factory built homes, a segment of the housing industry that accounts for about 12%–14% of the nation’s total annual housing sales.<sup>2</sup> The largest segment of the factory building industry, manufactured homes, historically has had to meet energy standards less stringent than current International Energy Conservation Code (IECC)-based codes. As a consequence, the industry has evolved few cost-effective options for reaching ambitious energy efficiency targets, such as the Building America goals. This research, design, and development (RD&D) effort will fill this void by creating and demonstrating new design and building practices that minimize cost, that can successfully be applied in a factory setting, and that result in substantial reductions in energy use. The research will yield new practices for building envelope components that meet these criteria and initiate the process of moving these practices into commercial use.

The majority of factory built housing manufacturers have been slow to adopt new building products and technologies on their own for many reasons, including: (1) the development costs are prohibitively high for any single manufacturer; (2) developing proprietary envelope solutions would be difficult to defend in the market, meaning that the RD&D investment by one company would benefit competitors; and (3) while most companies have engineering staff, they lack a tradition of building technology RD&D and are ill-equipped to conduct the type of cross cutting research that involves the complex set of interrelated technical issues envisioned for this project.

Success of the proposed work—the demonstration of how advanced envelope designs can replace conventional frame construction without a significant impact on total cost—will yield cornerstone technologies the industry will need in moving toward the nation’s ambitious energy efficiency goals. While the results of this research will have immediate application to manufactured homes, the technologies developed will have relevance for modular construction as well. Modular homes are subject to similar factory construction issues and manufacturing constraints and generally have a higher price point than manufactured housing, allowing for greater design flexibility.

## 1.1 Background

Although the potential benefits of proving high performance envelope component designs for factory application are huge, the technical hurdles for factory builders are formidable. Implementing changes to envelope components can engender a host of major changes in plant layout, workflow, materials handling, and safety issues. Potentially, some of the proposed changes would increase production rates while improving quality, magnifying the benefits of this research. Other elements of the needed research include assessing the impacts of changes on structural performance, moisture dynamics, integration of services, and code acceptance. This research effort sets the stage for elevating factory production to address these factors and fully and seamlessly incorporating advanced methods into the industrialized building fabric.

---

<sup>2</sup> Estimate derived from the National Modular Housing Council’s Quarterly Modular Housing Report and the Manufactured Housing Institute’s Monthly Economic Reports (2010). Source of the reports—[www.manufacturedhousing.org/reports/](http://www.manufacturedhousing.org/reports/) (available to Manufacturing Housing Institute members only). The percentage share shown is new factory built homes relative to the number of total new houses sold. This figure is in terms of number of housing units.

The industry's initial attempts to develop cost-effective approaches to improving energy performance (including the use of structural insulated panels (SIPs) and other open and closed cell insulation products) convinced many in the industry that such technologies have the potential to revolutionize manufacturing practice. However, the resources (financial and technical) needed to tackle the myriad interrelated challenges are well beyond the capacity and skills of a single manufacturer, or even a group of manufacturers. The other drag on innovation is the fact that the industry is highly competitive and advances underwritten by a single company are readily adopted by other manufacturers, diluting the value of the research investment. Patents are few and expensive to defend, in part explaining why most buildings-related research is conducted by product manufacturers, not home building companies.

This work initiates a new direction for Building America activities. Introducing new envelope construction practices in a factory setting will provide valuable insights into how high performance products can be applied to home building, yielding new measure guidelines and potentially identifying practices that can be used by site and componentized homebuilders.

## 1.2 Project Scope

The study is exclusively focused on advancing envelope design, and the current work is part of a multiphase effort to improve the performance of wall components. The team recognizes that having viable and cost-effective envelope technologies is a prerequisite to formulating whole-building solutions. The current research effort focuses on factory built homes located in IECC 2009 climate zones 5 and higher. Insulation requirements underwent significant changes for these northern, primarily heating-dominated climate zones that will benefit most from these research findings.

The approach to the project and scope is shaped by the following three overarching considerations:

- 1. Minimize cost, maximize performance:** One of the major challenges in the development process is creating a product design and fabrication method that minimizes total cost while maximizing product performance. Each product and process designer starts with a set of goals but must engage in a development process that arrives at a common, integrated, and optimized solution. The process of bringing diverse goals to a common development process, in which several disciplines simultaneously re-engineer the building product and process and work to integrate and synergize their solutions, is often referred to as *concurrent engineering*.<sup>3</sup>
- 2. Reinvent the whole system:** This research work is being driven by the unique requirements of factory homebuilding. Researchers seek synergies among building materials, automated production equipment, and information technology. Then, guided by the principles of lean production, researchers will explore how the whole system can

---

<sup>3</sup> Concurrent engineering benefits factory built housing more than other less industrialized forms of housing for several reasons, including the fact that the economics of the plant construction process are far more dependent upon speed, coordination of trades, and dimensional precision. In addition, quality control and coordination of the trades is more easily accomplished in the factory than at the building site.

be reinvented to dramatically improve quality, energy efficiency, safety, cost effectiveness,<sup>4</sup> productivity, and design flexibility.

- 3. System integration:** In all homes, but particularly in factory built housing, performance of systems, subsystems, and components is dependent on other systems within the structure, and improving performance in one area has collateral impacts elsewhere. For example, changes in the envelope subsystem intended to improve energy efficiency may affect the production process and may alter the structural characteristics of the home. Optimization of any single part of the home therefore depends on balancing considerations elsewhere. The team employs a systems approach designed to find combinations of changes that together improve overall performance when gauged relative to an objective baseline.

### 1.3 Research Partners

This effort is cooperatively sponsored by the Systems Building Research Alliance. Technical direction is provided by an industry-led Steering Committee acting under the Systems Building Research Alliance umbrella and consisting mainly of factory building company representatives. Participating insulation manufacturers are key contributors to the work and the concepts developed. ARIES team members facilitate the work and provide technical support, analysis, evaluation, and documentation. Members of the research team are listed below:

#### 1.3.1 Steering Committee

Michael Wade, Cavalier Homes, *Committee chair*  
Ronnie Richards, American Homestar Corp.  
Jayar Daily, American Homestar Corp.  
John Meredith, Beracah Homes, Inc.  
Jerome Alexander, BlueLinx Corporation  
Mark Klaus, Cavco Industries, Inc.  
Manuel Santana, Cavco Industries, Inc.  
Phillip Copeland, Champion Home Builders  
David French, Champion Home Builders  
Tony Watson, Champion Home Builders  
Mark Ezzo, Clayton Homes  
Gary Butler, Commodore Homes, Inc.  
Nader Tomasbi, Commodore Homes, Inc.  
Robert Bender, Commodore Homes, Inc.  
Jim Dunn, Eagle River Homes, Inc.  
Alan Behrent, Excel Homes, Inc.  
Delma Sheaffer, Excel Homes, Inc.

Bill Langdon, Forest River Housing, Inc.  
Luca Brammer, Hallmark—Southwest Corp.  
Mark Tackett, Louisiana Pacific Corporation  
Rex Swanson, Louisiana Pacific Corp.  
Lois Starkey, Manufactured Housing Inst.  
Mike Clementoni, Muncy Homes, Inc.  
Rich Bird, Muncy Homes, Inc.  
Woody Bell, Nationwide Custom Homes  
Andy Miller, Nationwide Custom Homes  
Eric Tompos, NTA, Inc.  
Bert Kessler, Palm Harbor Homes  
Bryan Huot, Preferred Building Systems  
Richard Shives, Premier Builders  
Terry Dullaghan, Senco  
Tom Tracy, Senco

---

<sup>4</sup> Cost effectiveness is a general expression intended to convey that costs and benefits have been balanced using some generally accepted econometric process.

### **1.3.2 Insulation Manufacturers**

Mike Tobin, AFM Corp.  
Paul Fox, BASF  
Brian Lieburn, Dow Corp.  
Bryan Mallon, Dow Corp.

Francis Babineau, Johns Manville Corp.  
Craig Marden, Owens Corning  
Jon Grittich, Owens Corning  
Daniel Small, Saint-Gobain/CertainTeed

### **1.3.3 ARIES Technical Team**

Emanuel Levy, The Levy Partnership, Inc.  
Michael Mullens, The Levy Partnership, Inc.  
Pournamasi Rath, The Levy Partnership, Inc.

## **1.4 Research Process**

The research will develop the next generation of envelope component designs for the factory building industry. This work consists of identifying alternative options, critically evaluating their potential to meet a set of performance goals, selecting option(s) for development, developing a design/engineering solution for the option(s), and testing and evaluation. The project spans several years and is divided into four phases as follows:

- Phase 1. Identification and characterization of options.** Completed in 2011, this phase identified a wide range of innovative envelope technologies that were culled down to a short list of three methods for building high performance wall systems.
- Phase 2. Preliminary design.** Completed in January 2012, Phase 2 focused on the development of viable product designs, manufacturing strategies, addressing code and structural issues, and cost analysis of the three innovative wall concepts. An industry advisory committee was convened to help critique and select the most viable solution.
- Phase 3. Design development and prototyping.** Phase 3, divided into two stages, focused on design development exploring variations on the use of exterior CI, one of the three core concepts. The scope of work also included material selection, manufacturing and cost analysis, and prototyping and testing.
- Phase 4. Advanced testing, proof of concept, and market readiness.** Phase 4, started in late 2013, includes comparative testing and analysis of wall designs that feature exterior CI. The work will identify designs with the greatest market potential, and begin to clear the code, production, and design hurdles to commercial use.

The research methods and results of Phases 1 and 2 are discussed in detail by Levy et al. (2012a) and Levy et al. (2012b).

Phase 1 of the Advanced Envelope Research was initiated in early 2011. Leading insulation companies were invited to present envelope solutions with project potential. The presentations provided numerous ideas that were debated and discussed by the industry advisory committee. The concepts were honed by the ARIES team and narrowed to a short list of seven candidate technologies, as follows:

- SIPs for ceilings
- SIPs for walls
- Stud wall with insulating sheathing board

- Unvented attic with exterior CI
- Flash and batt wall construction
- Poured closed cell foam
- Innovative new floor design.

Following a preliminary design development of the seven identified options, a qualitative assessment was conducted for the selected technologies. The advisory committee and industry experts rated the options and selected the following for subsequent research:

- SIPs for walls
- Stud walls with exterior CI
- Flash and batt wall construction.

In Phase 2, the three concepts were further developed and refined. The ARIES technical team and the industry advisory committee discussed the findings, identifying those that were most cost effective and had potential wide market appeal and application (potentially attractive to most manufacturers). Subsequently, one technology—based on the use of continuous exterior sheathing combined with batt insulation—was deemed by the committee as having the greatest commercial potential.

Phase 3, divided into two stages, focused on detailed design development and prototyping and testing. Also included in the work scope was exploring variations on the design concept, material identification, manufacturing process evaluation, and cost analysis. Stage 1, completed in February 2013, developed multiple variations on the use of exterior CI, of which two were selected for prototyping and testing, conducted in Riverside, California. Research work and findings are discussed in detail by Levy et al. (2014).

### **1.5 Research Questions**

This phase of the research continued to seek answers to the following questions from the previous phase:

- What options exist for building wall components that incorporate off-the-shelf or readily developable CI sheathing materials that minimize cost, substantially improve thermal performance, and leverage the inherent efficiencies of factory production?
- What are the detailed performance characteristics of such a wall system?
- What are the major technical hurdles to using CI in the factory environment? To what extent can these barriers be surmounted by further research and product development?

## 2 Mathematical and Modeling Methods

### 2.1 Cost-Benefit Analysis

Thermal modeling and cost-benefit analysis were performed using BEopt<sup>®</sup> (Building Energy Optimization) software developed by the National Renewable Energy Laboratory for the purpose of analyzing options based on their relative cost effectiveness. However, one of the primary goals of the research is to achieve a fixed wall thermal value based on future code requirements. Therefore, the measure value (thermal resistance) was fixed and BEopt was instead used to determine if the marginal costs involved in upgrading to the advanced wall are justified by the energy savings. Results of the analysis are provided in Section 4.6.



### 3 Research/Experimental Methods

Experimental methods for this research project comprised the following tests/evaluation methods:

- Wall panel mockup demonstration
- Whole-house prototyping of advanced wall system.

#### 3.1 Wall Panel Mockup Demonstration

Wall panel mockup demonstration was conducted to assess the fabrication sequence and manufacturability of the selected wall option. The panel was assessed based on the following factors: assembly, production, fastening techniques, door/window installation evaluation, transportation impact, and other related issues.

##### 3.1.1 Mockup Specifications

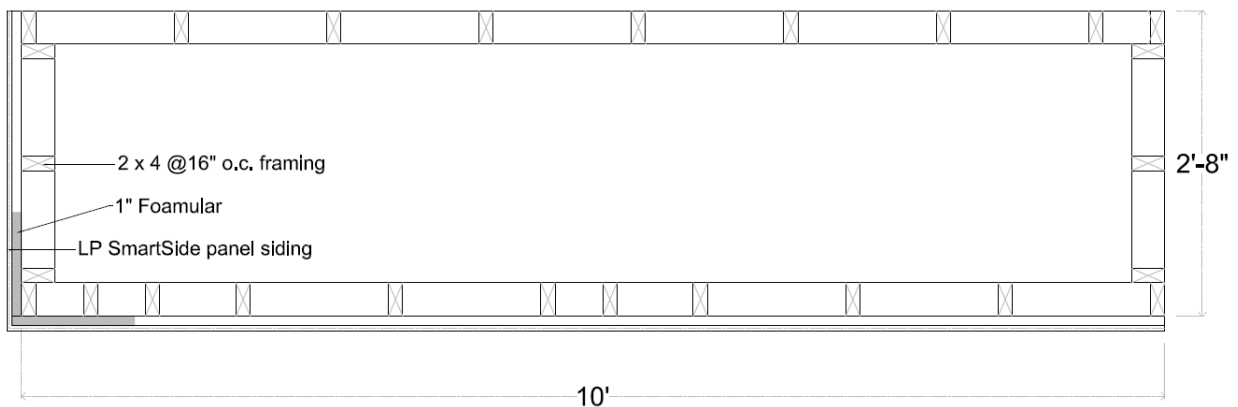
Specifications and details of the wall panel planned for mockup with the selected wall design are listed in Table 1.

**Table 1. Mockup Panel Specifications**

Item	Specifications
Testing Apparatus	See Section 3.1.2
Insulation	1 in. thick R-5 extruded polystyrene (XPS)
Framing	2 in. × 4 in. @ 16 in. o. c.
Furring or Strapping	N/A
Oriented Strand Board (OSB)	N/A
Siding	7/16 in. LP Smartside panel siding
Fasteners	See Section 4.2.3

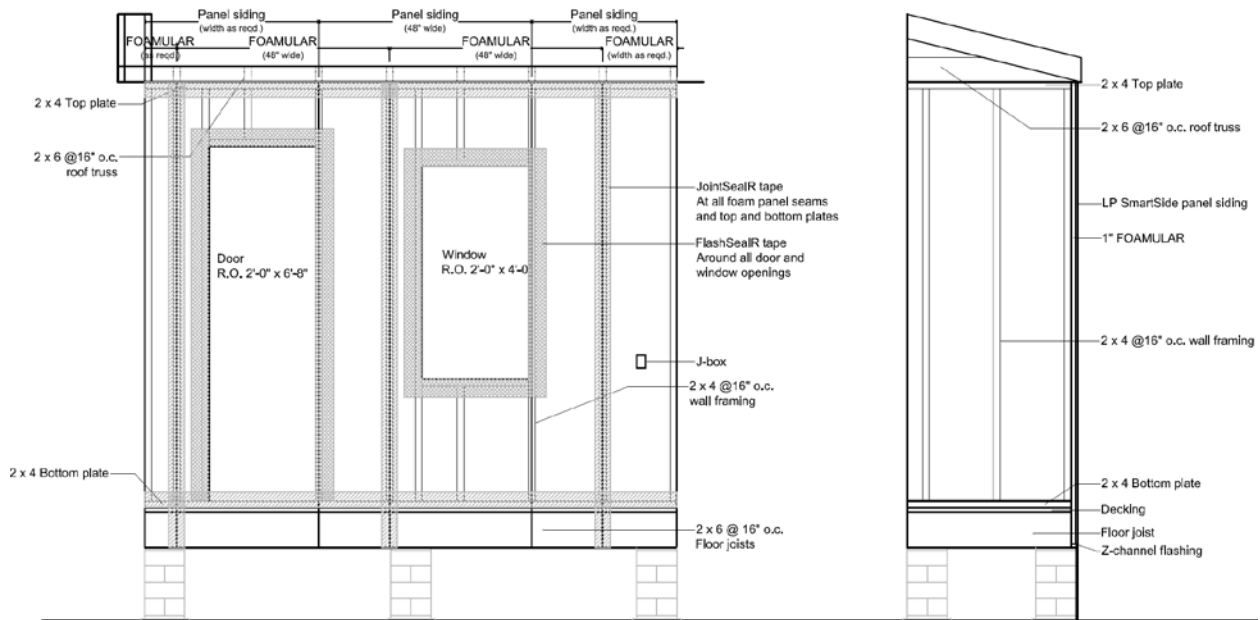
##### 3.1.2 Testing Apparatus

The apparatus for the wall mockup consisted of a boxed frame that measured 10 ft × 2 ft-8 in. in plan and 8 ft high. Studs in panels were 2 in. × 4 in. @16 in. o.c. A partial floor and partial roof was fabricated for the frame to receive the walls. A plan view of the boxed frame is shown in Figure 1.



**Figure 1. Plan view of the mockup frame panel**

Figure 2 shows the front and side elevations of the testing apparatus framework. The front panel includes a door and a window opening.



**Figure 2. Front elevation (right) and side elevation (left) of the mockup frame panel**

### 3.1.3 Assessment Criteria

The framing panel was assessed based on the following factors: assembly, production, installation of doors and windows, fastening techniques, and other related issues. The wall panel mockup demonstration sought answers to the following additional research questions:

#### 3.1.3.1 Assembly/Production

- Are there issues with handling CI, such as weight, dimensional stability, ease of positioning, tacking, etc.?
- What are the best methods of routing CI only or CI with siding?
- What are the best methods for minimizing waste?
- Should window/door openings be cut out of the CI sheet after installation on the wall or should the CI be installed around the openings using smaller precut pieces?
- What are the best methods of consistently hitting studs with fasteners?
- What are the best methods of applying joint tapes?

#### 3.1.3.2 Fasteners

- Is the fastening schedule reasonable?
- Do the specified siding fasteners ensure required penetration into the framing?
- Is furring required?

- Does the nailing gun ensure adequate and consistent air pressure to avoid nail popping during transportation and wall build?
- Does the siding dimple during fastening?
- Does the nailing gun require pressure adjustment on the line for different products?

**3.1.3.3 Door/Window Construction Assessment**

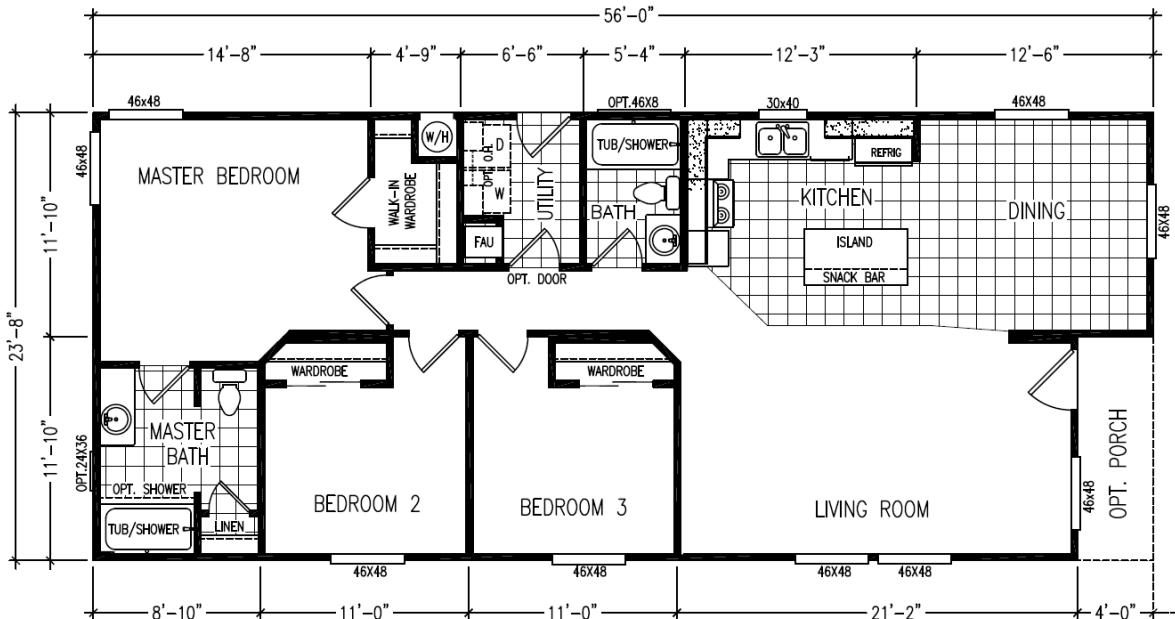
- What are the best methods of installing windows?
- Do windows require additional structural support?
- What is the best approach for extending the depth of door/ window jambs to provide a flush surface for the interior trim?
- Is the door swing impacted by the additional foam thickness?
- What is the impact of insulation on the construction of the water heater door?

**3.2 Whole-House Prototyping**

Whole-house prototyping was conducted for the selected advanced wall system. Karsten Homes in Sacramento hosted the full-scale prototyping and testing event. Below are specifications and drawings of the prototype home, followed by the in-plant and on-site testing criteria.

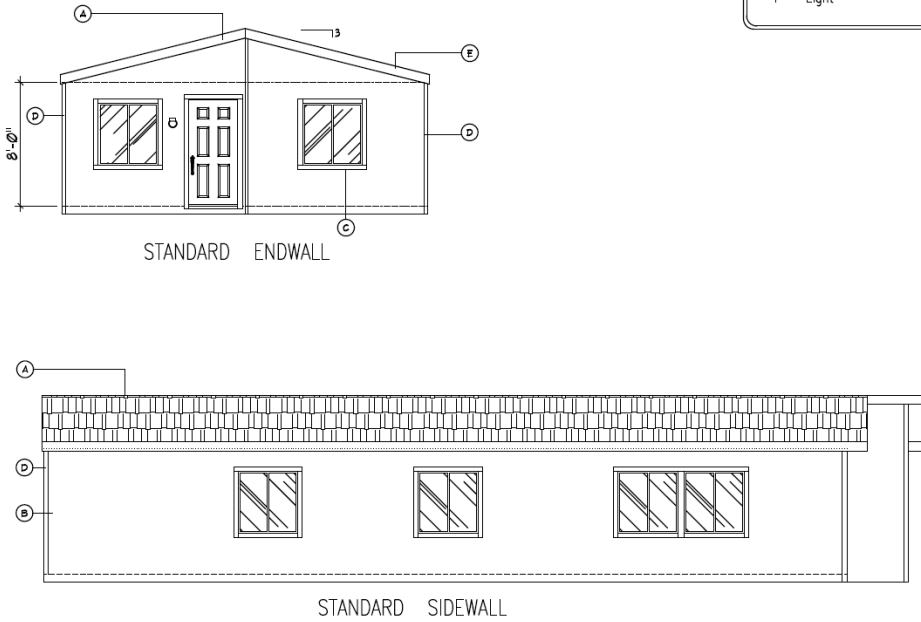
**3.2.1 Prototype Home Drawings and Specifications**

Figure 3 through Figure 5 show construction drawings of the factory built home that was used for full-scale prototyping of the selected advanced wall design.

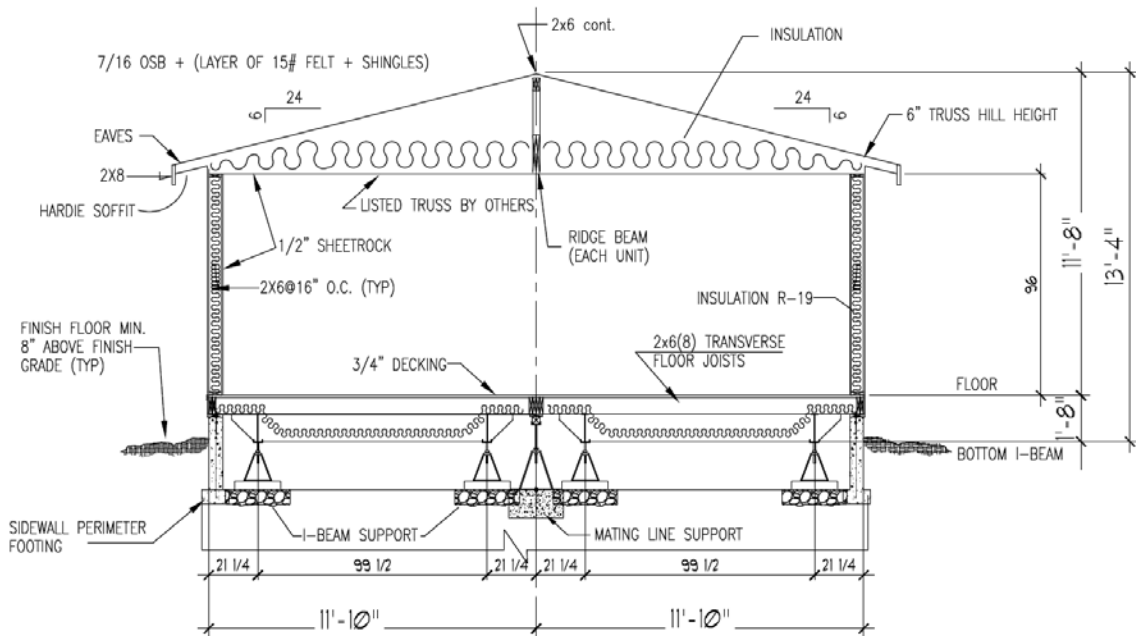


**Figure 3. Plan of the full-scale prototype home**

Legend	
A	- Composition Shingle Roof
B	- Hardboard 8" V-Groove - (Body Color)
C	- 1x3" Rough Sawn - (Trim Color)
D	- 1x3" Rough Sawn - (Body Color)
E	- 2x8" Rough Sawn - (Trim Color)
F	- Light



**Figure 4. Elevations of the full-scale prototype home**



**Figure 5. Typical cross-section**

Note: Shown figure is a typical cross-section of a manufactured home built by Karsten Homes. The prototype home has R-11 fiberglass batts in the cavity of 2 × 4 stud framing in the walls. There are no eaves on the prototype home.

### **3.2.2 In-Plant Testing Criteria**

#### **3.2.2.1 Documentation and Evaluation of Construction Detailing and Material Use**

An assessment was conducted of the constructed prototype with regard to developed construction details, joinery methods, material and equipment requirements and handling, skills needed, and other performance and assembly attributes.

#### **3.2.2.2 Manufacturing/Production Process Analysis**

During the prototyping and testing in plant, the construction sequence was observed and documented in detail. The production analysis included workstations involved, process teams, methods/tools/equipment, material staging/layout, etc. Evaluation and assessment of issues with the process were performed, and data related to key metrics (cycle time, process duration, throughput, labor hours, material wastage, quality, safety, etc.) were collected. Analysis of the construction process focused on impacts of incorporating CI on key performance metrics (safety, quality, timing/line flow, labor content, floor space, and facility/equipment costs). The analysis is intended to provide a measure of the impact of the anticipated changes on key production performance metrics.

### **3.2.3 On-Site Inspection Criteria**

#### **3.2.3.1 HUD Transportation Test (Section 3280.903 of the HUD Standards).**

This test is observational and performed to identify the cumulative effect of highway transportation, including shock, vibration, etc. on home durability and building integrity.

## 4 Results: Phase 3—Design Development and Prototyping (Continued)

Phase 3 of the Advanced Envelope Research focused on the detailed design development and prototyping of wall designs based on the use of CI. This option was selected by the industry-led Steering Committee as the most viable wall concept to move further in the research process.

### 4.1 Overview of Phase 3

Phase 3 consisted of two stages; Stage 1 of Phase 3 focused on exploring variations on the use of exterior foam insulation and developing wall options based on superior insulation products so that wall performance and functionality is optimized for factory built housing. This information provided the basis for the industry committee to compare and contrast the options to select promising designs for prototyping and testing, also conducted in this phase of research. In this stage, two of five selected alternative material options for achieving CI were prototyped at a manufacturing plant. The mockups were assessed for producibility, structural capacity, and ease of window framing. Research work and results of Phase 3-Stage 1 are discussed in detail in Levy et al. (2013).

Stage 2 of Phase 3, the subject of the current report, focused on the detailed design development of one of the five wall designs selected in Stage 1: stud walls with XPS rigid insulation. Wall panel frame mockup was conducted to identify issues with and assess ease of construction. This was followed by full-scale whole-house prototyping and testing in plant and evaluation after installation on site.

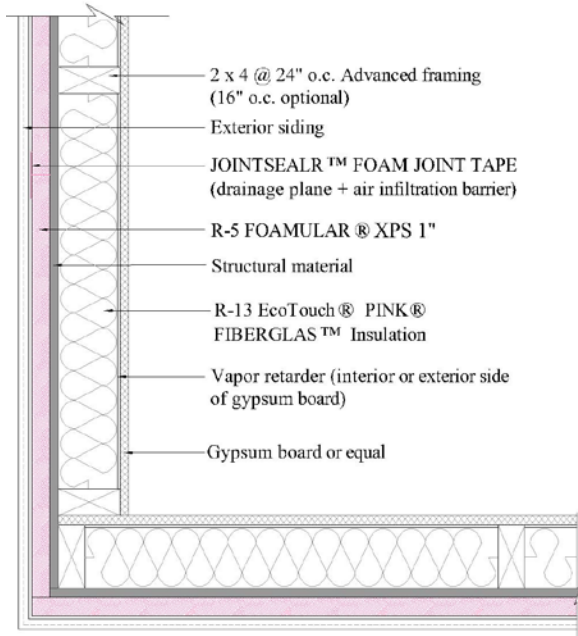
### 4.2 Advanced Design-Development

#### 4.2.1 Design Specifications

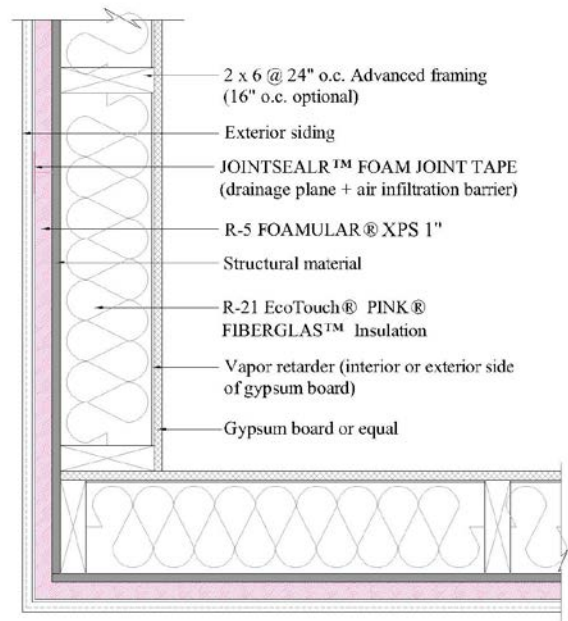
In conducting research on the use of CI for wall construction, the ARIES team has experimented with several expanded polystyrene (EPS) products that provide a minimum of R-5 for a 1-in. thickness. The product used for this phase was Foamular, a proprietary product manufactured by Owens Corning and part of its Residential Complete Wall System platform.<sup>5</sup> Figure 6 is a wall section of this proposed concept for climate zone 5. Figure 7 shows the wall design meeting code requirements for climate zones 6, 7, and 8 with R-21 cavity and R-5 exterior insulation.

---

<sup>5</sup> In general, in referring to the insulating foam wall sheathing material the term *continuous insulation (CI)* or *expanded polystyrene (EPS)* is used. In a few instances, where there is a reference to detailed material characteristics, the proprietary designation, Foamular, is noted. Foamular (and related products, such as JointSealer Tape) is one of many commercially available products that can be used to meet the needs for a CI in a factory building setting.



**Figure 6. Stud wall with CI, Design 1 (climate zone 5)**



**Figure 7. Stud wall with CI, Design 2 (climate zones 6, 7, and 8)**

Table 2 lists some of the features and physical properties of Foamular.

**Table 2. Physical Properties of Foamular 250 XPS**

Item	Property
<b>Insulation Brand Name</b>	Foamular 250
<b>Insulation Type</b>	XPS
<b>Product Thickness @ R-5</b>	1 in.
<b>Perm Rating @ 1 in.</b>	Class III (1.5 perm)
<b>Compressive Strength</b>	25 psi
<b>Integrated Water and Air Barrier</b>	Yes, with joint tape
<b>Shear Resistance</b>	Not significant
<b>Strengths</b>	<ul style="list-style-type: none"> <li>• Can be cut with a saw, hot wire or scored and snapped</li> <li>• Zero ozone depletion potential indicating negligible degradation to the ozone layer</li> <li>• Maintains at least 90% of its R-value over the lifetime of the product and covers all ASTM C578 properties</li> <li>• Contains minimum 20% recycled content</li> </ul>
<b>Limitations</b>	Nonstructural
<b>Weight</b>	0.13 psf for 1 in.
<b>Available Panel Sizes</b>	Width: 16 in., 24 in. or 48 in.; height: 96 in. or 108 in.

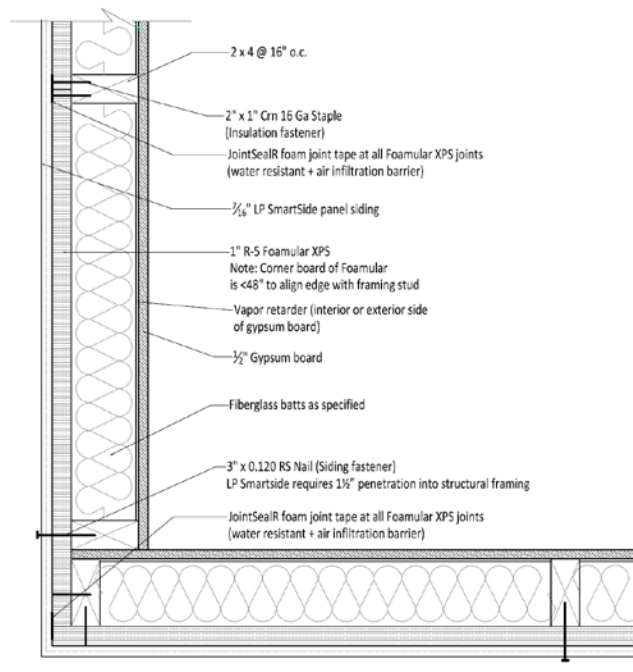
Table 3 provides information on the tests and approvals with the use of Foamular 250 XPS insulation.

**Table 3. Product Tests and Approvals on Foamular 250**

Item	Test type
<b>Tests Completed</b>	<ul style="list-style-type: none"> <li>• Product data sheet (<a href="http://www.foamular.com/assets/0/144/172/174/11b5f50a-0f80-4f08-bebe-71f4b6a9fdf7.pdf">www.foamular.com/assets/0/144/172/174/11b5f50a-0f80-4f08-bebe-71f4b6a9fdf7.pdf</a>)</li> <li>• ICC ES Report ESR-1061 (<a href="http://www.icc-es.org/reports/pdf_files/SBC/ESR-1061.pdf">www.icc-es.org/reports/pdf_files/SBC/ESR-1061.pdf</a>)</li> <li>• Meets ASTM C578 Type IV (Std. for rigid polystyrene insulation) (<a href="http://foamular.com/assets/0/144/172/174/068b3c93-7431-43c4-8d43-53e09ea0b584.pdf">http://foamular.com/assets/0/144/172/174/068b3c93-7431-43c4-8d43-53e09ea0b584.pdf</a>)</li> <li>• UL Classified</li> <li>• ASTM E2178-03 (air permeance)</li> <li>• NFPA 285 (fire tested wall assemblies)</li> </ul>
<b>Tests Required for HUD Approval</b>	None

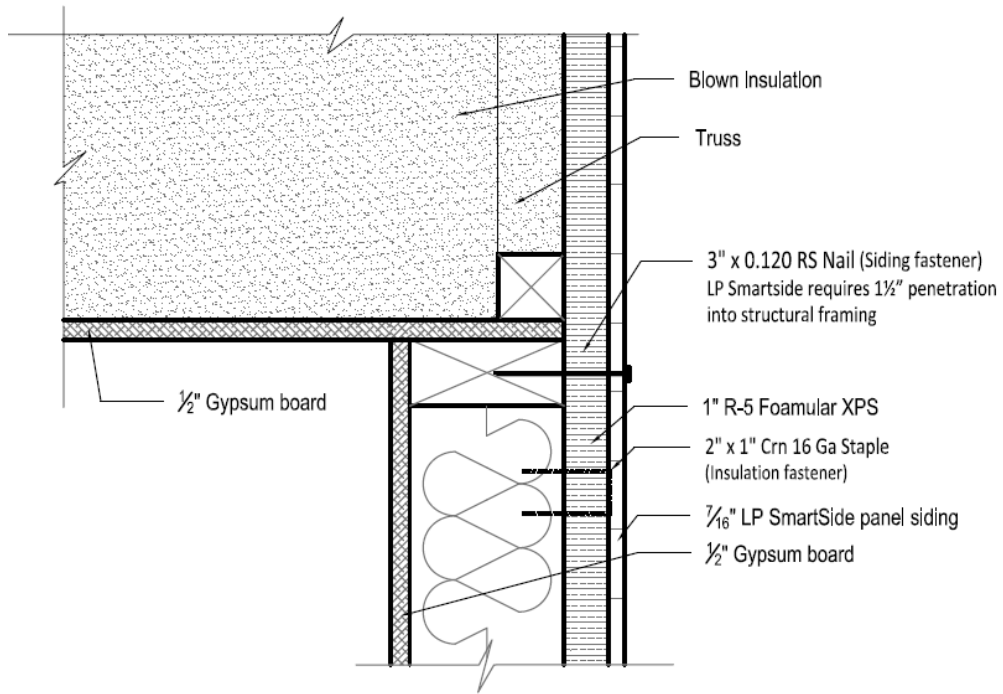
**4.2.2 Construction Drawings**

Figure 8 through Figure 12 are construction details incorporating the exterior CI to the wall assembly.

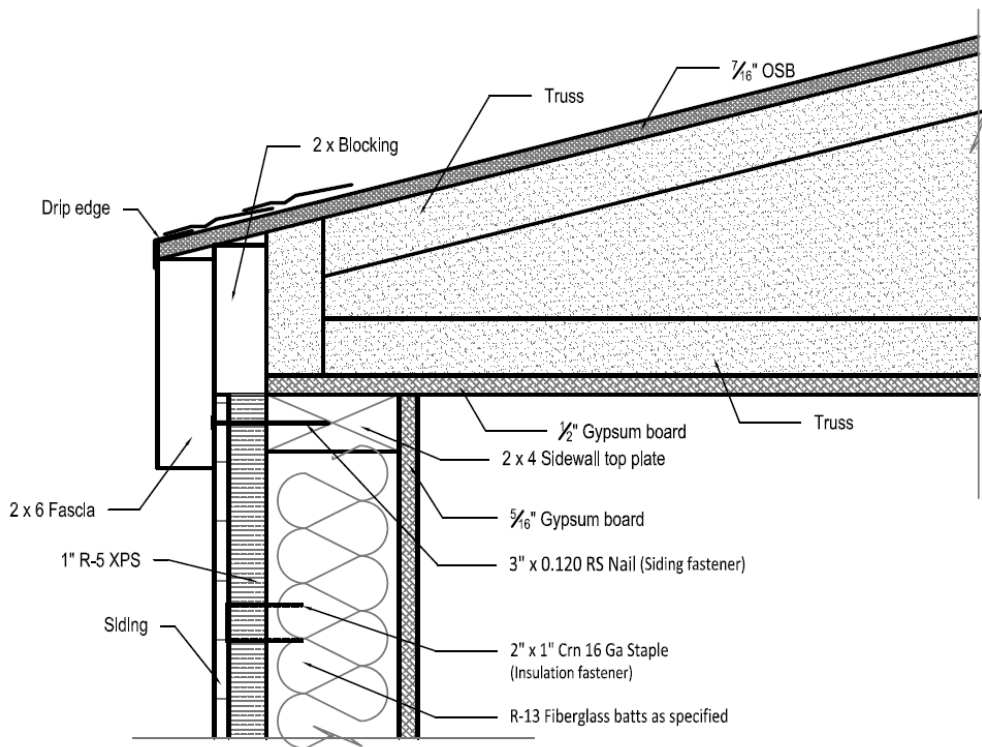


**Figure 8. Plan view of wall detail**

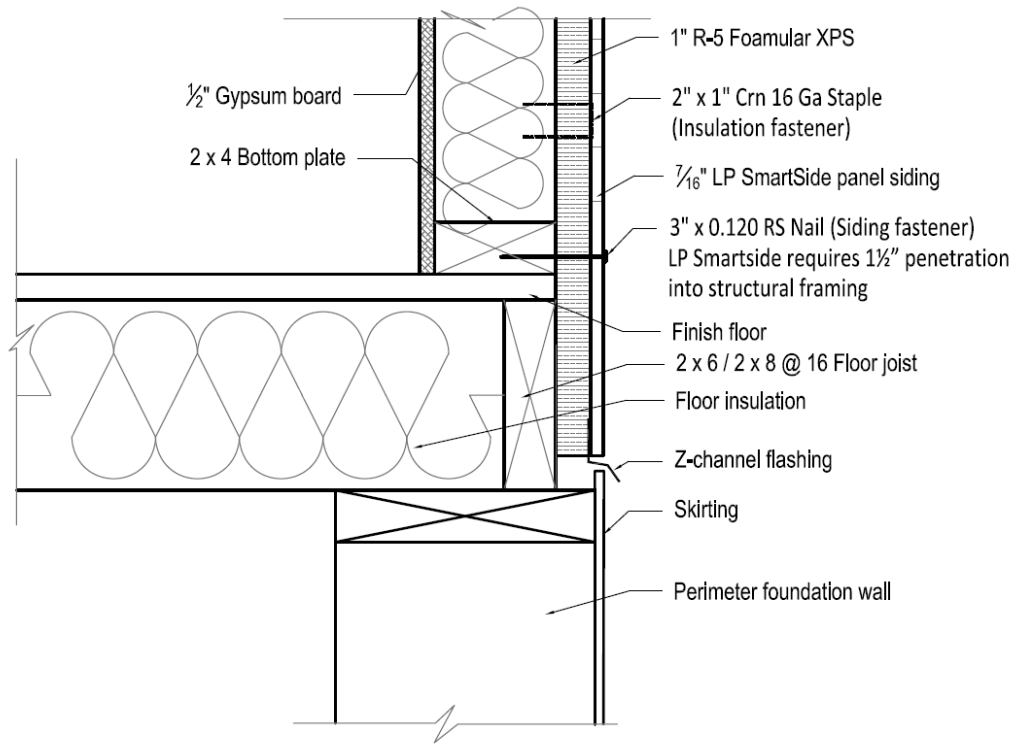




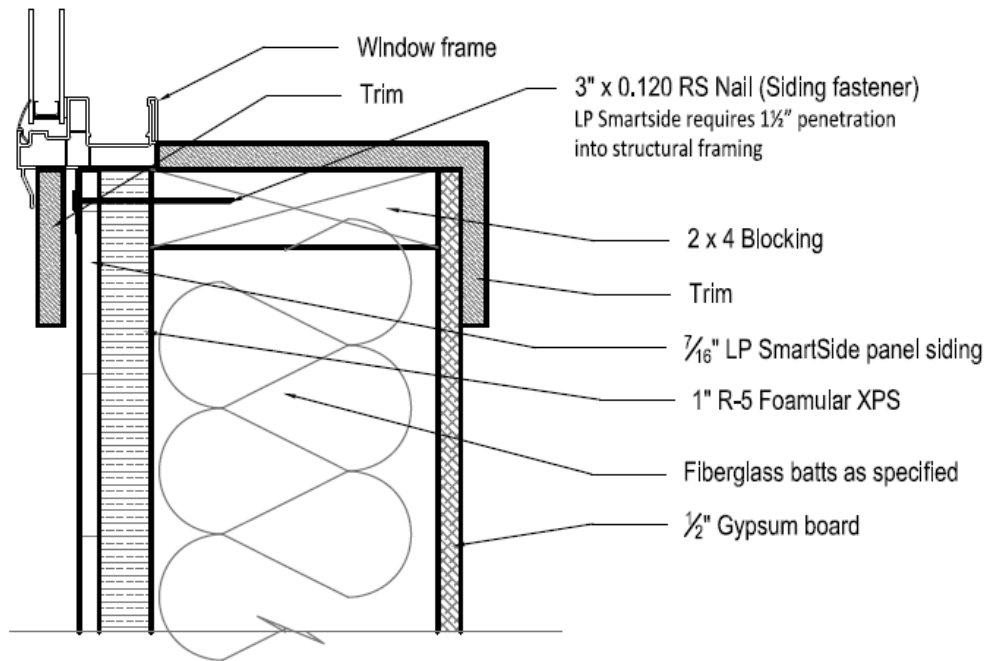
**Figure 9. Detail at top plate (gable wall section)**



**Figure 10. Detail at roof-wall connection (side wall section)**



**Figure 11. Detail at foundation**



**Figure 12. Detail at window sill**

### 4.2.3 Attachment Methods

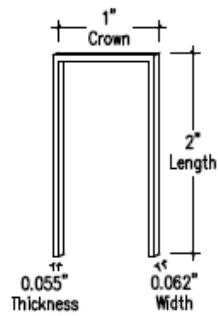
Specifications on fasteners and tools required to attach CI to the framing and the cladding are shown in Table 4 and discussed below.

**Table 4. Fastener Specifications**

Item	Specifications
<b>Framing</b>	2 in. × 4 in. @ 16 in. o.c.
<b>Fasteners and Tools</b>	See below
<b>Cladding Attachment</b>	LP Smart side 7/16 in. —Nail (3 in.) ( <a href="http://www.lpcorp.com/smartside/panel/">www.lpcorp.com/smartside/panel/</a> , <a href="http://www.lpcorp.com/resources/literature">www.lpcorp.com/resources/literature</a> )
<b>Furring or Strapping</b>	Not required

#### Insulation staple

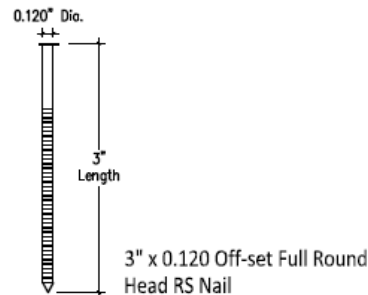
Senco 2 in. × 1 in. crown 16 gauge staple



2" x 1" Crn 16 Ga Staple

#### Siding nail

Senco 3 in. × 0.120 RS Nail



#### Tools

Staple gun: WC200 XP-16 gauge, 1 in. wide crown, 2 in. heavy wire stapler

Nailing gun: SN951XP-4 in. 34 clipped head framing nailer

The fastening schedule for stapling the CI to the frame and nailing the siding in was specified as: one every 6 in. along the perimeter and one every 12 in. in the field.

### 4.3 Code Compliance Evaluation

The CI product being prototyped in Stage 2, Foamular 250 XPS insulation, was evaluated for use in the wall construction of manufactured homes, under the Manufactured Home Construction and Safety Standards. It was found that the inherent properties of the material meet the requirements of XPS/EPS foam plastic in use in the cavity of walls or ceilings as sheathing or backer board for exterior coverings. See the Appendix for the detailed report.

#### **4.4 Wall Mockup and Whole-House Prototyping**

Stage 1 of Phase 3 consisted of a first round of mockup and testing of CI products under test conditions. This stage involved the following two foam sheathing products:

- Stud walls with Styrofoam (in collaboration with Dow Corporation)
- Stud walls with Foam-Control Nailbrace (in collaboration with AFM Corporation).

The tests, conducted over a 2-day period, consisted of structural racking tests and the fabrication of wall panel mockups. These tests were helpful in understanding modes of structural and product failure and identified product assembly and material/product integration issues. Stage 1 resulted in several changes in design and was the basis for production planning.

Stage 2 consisted of a second mockup and the production of a full-scale prototype home. The details of the tests and findings are discussed in the sections that follow.

##### **4.4.1 Location and Participants**

Wall mockup and full-scale testing of the selected wall solution were conducted on October 2 and 3, 2013 in association with partner manufacturing plant, Karsten Homes, Inc. (Sacramento, California). Karsten Homes is a subsidiary of Clayton Manufactured Homes. Participating in the tests were members of the Technical Steering Committee, Owens Corning technical staff, representatives of related product providers (fasteners, siding, etc.) and the ARIES technical team. Karsten management and plant staff collaborated on planning, helped formulate the manufacturing plan, and were instrumental in resolving production problems as they arose.

##### **4.4.2 Wall Mockup Observation and Evaluation**

The purpose of the wall mockup was to consider issues that will arise in the plant when using the CI in factory production. The design of the mockup apparatus was based on work conducted in Stage 1 (see Section 3.1 for details on the testing protocols, design of the testing apparatus, and assessment criteria).

The mockup process simulated elements of the construction process identifying steps in the material and product assembly (fastening, door/window framing, etc.) that had the potential to slow production or adversely impact quality. The discussions that follow highlight the main findings of the mockup simulation (related research are covered in Section 3.1.3).

###### **4.4.2.1 Lessons From the Mockup Demonstration**

The construction of the prototype wall panel helped acquaint key production staff with the use of CI and expose and begin to resolve issues that otherwise might slow production. Two major concerns arose during the prototyping with the potential to negatively impact plant flow: the use of tape at the panel seams and the method of cutting window and door openings.

- **Taping of seams.** Taping of the insulation seams during mockup was a slow, arduous process and the team feared that this process would significantly slow production. Application of the tape required practice and discussion ensued with regard to the utility of commercially available taping tools. The team considered eliminating the taping but was concerned that other sealing techniques would not provide a sufficiently weathertight barrier. However, during prototyping, the plant staff quickly adjusted to the taping

process, and this concern abated somewhat (although a better taping method is needed—see Section 4.4.3).

- **Cutting openings.** After several unsuccessful attempts to cut openings after the insulation and siding were applied, the team concluded that a fast and accurate cutting of openings required a routing tool not available for the prototyping. As an interim measure, the plant quality control manager used a handheld circular saw to cut the openings. This proved somewhat imprecise but adequate for the prototype. This interim solution is not an option going forward. Precise and clean routing of the insulation and siding will require locating the proper router bit with sufficient length to penetrate the materials and rest on the framing as a guide.

Following the mockup and prior to whole-home prototyping, the plant and production staff met to review the production issues and develop a manufacturing strategy. This pre-construction visualization and coordination of tasks proved valuable; the production team was well organized and able to respond to challenges efficiently.

The discussions that follow in Section 4.4.3 provide a summary of the concerns expressed in advance of the prototyping or issues that arose during the actual home build and, where appropriate, the responses or action that resulted.

Below are findings from the wall panel mockup demonstration in response to the research questions identified in Section 3.1.3.

#### 4.4.2.2 *Assembly/Production*

- Are there issues with handling the CI material, such as weight, dimensional stability, ease of positioning, tacking, etc.?

**Finding:** For plant staff used to moving board materials, such as OSB, CI is relatively easy to handle in terms of the weight, dimensional stability, ease of positioning, and tacking.

- What are the best methods of cutting openings in CI only or CI with siding?

**Finding:** While not demonstrated, the consensus view is that the best method of cutting CI is by a router with a sufficiently long bit to cut through the siding and the CI in a single pass using the framing as a guide.

- What are the best methods for minimizing waste?

**Finding:** Precutting pieces and using smaller leftover pieces at the gable end would minimize waste.

- Should window/door openings be cut out of the CI after installation on the wall or should smaller, precut pieces be used that would eliminate waste but require more custom cutting?

**Finding:** Cutting the door and window openings following the sheathing process was faster and less prone to quality issues.

- What are the best methods of consistently hitting studs with fasteners?

**Finding:** The production team suggests that the CI manufacturer print lines on the CI material that correspond to the stud spacing.

- What are the best methods of applying tape at the joints?

**Finding:** Tape is applied at all seams of the CI panels including corners. The best method of applying the tape is to have one worker position and hold the tape at one end of the seam while the other rolls it over the length of the seam. At the corners, it was decided that the best method would be to tape it on the side of the panel joint with the edge of the tape flush with the corner edge. Having the tape wrap over to the other side was deemed unnecessary while requiring extra labor.

#### 4.4.2.3 Fasteners

- Is the fastening schedule reasonable?

**Finding:** The fastening schedule (see Section 4.2.3) was deemed adequate by the insulation and siding manufacturer representatives and the plant staff.

- Do the specified siding fasteners ensure required penetration into the framing?

**Finding:** Yes, 3 in. long nails were specified to attach the 7/16 in. thick siding to the studs through the 1 in. of CI. The manufacturer of the panel siding (SmartSide by Louisiana Pacific) requires 1.5 in. of fastener penetration into the framing member.

- Does the nailing gun ensure adequate and consistent air pressure to avoid dimpling during fastening and nail popping during transportation and wall build?

**Finding:** Yes, the nailing gun pressure could be accurately adjusted to ensure adequate and consistent air pressure to avoid nail popping and dimpling.

- Does the nailing gun require pressure adjustment on the line for different products, a step that might slow production?

**Finding:** While the nailing gun did not require pressure adjustment on the line, every siding nail type required the hammer to be reset. This was not considered a significant issue.

#### 4.4.2.4 Door/Window Construction Assessment

- What are the best methods of installing windows?

**Finding:** Cutting window openings with a router with longer bit and installing the frame on the wall assembly, followed by attaching the siding to the frame, is likely to be the best and most efficient method of installing windows. This will be investigated in latter stages of the work.

- With the windows resting partly on the insulation, is additional structural support required?

**Finding:** According to the window supplier, the structural rating of the CI (25 psi) provides sufficient support. While anecdotal, it should be noted that no window displacement or movement was observed after the homes were transported to the building site.

- What is the best approach for extending the depth of door and window jambs to provide a flush surface for the interior trim?

**Finding:** For the Karsten plant, the best approach was to insert blocking that extended the jamb depth and provided a flush surface for the interior trim.

#### 4.4.3 Whole-House Prototyping Observation and Evaluation

The foam panels provide a CI layer that is durable, virtually eliminates thermal bridging, and can be installed in the plant with little training. Application of the tape to the joints enabled the material to also serve as an air and water resistive barrier, providing potential cost savings by eliminating the need for a separate material to serve this function. The relative high density and compression strength of the foam appears to be sufficient to allow the window to bear partially or entirely on the foam, enabling the use of fairly simple window and door framing details.

General observations and items that require further analysis and development are described below:

##### 4.4.3.1 Construction Detailing

- **Panel sizes.** The exterior wall height, including the rim joist, is about 9 ft but the available Foamular panels were 4 ft × 8 ft sheets. This resulted in the need to tack 6 in. strips along the rim joist adding a cutting and tacking operation and requiring additional taping, steps that can be eliminated by the use of 9 ft boards.
- **Panel fabrication.** The width of the foam boards supplied by the insulation manufacturer was inconsistent, ranging between 48¼ in. to 48½ in. (likely due to a fabrication error). Since the edges did not fall perfectly on each stud several workarounds were needed to secure the panel edge to framing. Initially, a backer stud was used at a few joints. Later, every second or third foam sheet was trimmed to compensate for the width variation. In both cases, there was an addition of labor. The backer board added extra lumber cost that was significant and unnecessary making the trimming option more acceptable to compensate for errors in panel dimensions. This was assumed to be an isolated manufacturing error that contributed to slowing of the line flow.



- Corner framing detail was handled well without creating a thermal bridge. The CI was trimmed to overhang the end by 1 in. catching the adjacent board and providing a tight foam seal around each corner.



#### 4.4.3.2 *Installing Windows and Doors*

- **Cutting openings.** As noted earlier, the cutting of openings in the foam and siding requires a better resolution. For the prototype, the quality control manager took responsibility for this work by first cutting a starter hole and then using a handheld circular saw guided by the rough framing. This was time consuming and occasionally imprecise. The general view was that a router with the proper bit (not available at the time of the prototyping) would resolve this problem.
- **Window bearing.** The design of the windows results in the frame bearing entirely on the foam. While this detail was approved by the window manufacturer, and conforms to code, the team noted the need to assess the durability of this detail following transportation.





- **Door jambs.** Standard depth door jambs need an extra 1 in. blocking to the interior to provide a flush surface. While the door swing at the test home was not impacted, if there isn't a perpendicular wall on the hinge side of the door (limiting the door swing beyond 90 degrees), the deeper opening may itself limit door swing. The door on the test home is located to the exterior of the opening. A door designed for a 6 in. wall might be a better solution.



#### 4.4.3.3 Fastening and Taping

- **Locating fasteners.** The foam wall sheathing was tacked to the framing with 2 in. long, 16 gauge staples. The staples hold the insulation in place until the siding is installed with nails that secure both the siding and foam with a required framing penetration of 1½ in. Because the fastening process is blind (studs are not visible from the exterior) there continues to be an issue of the staples not hitting the studs. Stud locations were approximated by measurement. However, this method is not perfect and there were a few instances where the staples did not hit the stud. One solution is to print stud patterns on the insulation material.



- **Taping method.** FoamSealR tape was applied at all seams allowing the CI to perform serves as the weather and air barrier. Taping is a two-person job and was considered fairly easy despite early concerns that tape application would significantly impact quality and production speed. Still, the hand application added labor and is among the potential areas for improvement. One suggestion was to try various taping tools that could be used on the main production line.



#### 4.4.3.4 Assembly/Production

- **Line stoppage.** The Karsten team made the decision to complete all of the sheathing and finishing operations in a single station rather than spread tasks out over several stations. Additional staff was assigned to the prototype effort, unbalancing the line and slowing work on other homes. This was an expedient solution for the prototype but is clearly not a model for routine production. Concentrating work at a single station distorted flow and made it difficult to quantify the impact of adding foam to overall plant cycle time. However, as a general observation, the staff did an excellent job of adapting to a new material, problems were resolved quickly, and the operations on the prototype did not appear to add significantly to production time. This bodes well for future production using foam sheathing.



#### 4.4.4 On-Site Inspection Results

The test home was subject to a transportation test, a visual inspection, and observational evaluation performed to identify the cumulative effect of highway transportation including shock, vibration etc., on wall durability and performance.

The home was inspected twice; first upon arrival at the destination site and subsequently after the installation process was completed. Initial inspection of the unit, conducted on November 4, 2013, reported no indications of separation of panels and no visual signs of nail pops or loosened connections; the obvious potential modes of failure. There were a few interior wall cracks, not uncommon to factory built homes transported over the road (see Figure 13). Following setting of the home on site, the second inspection was conducted on November 21, 2013. No other visually evident defects or degradation were noted as a result of the installation and setting process. Overall, no damage to the home was observed that could be attributed to the additional layer of exterior CI on the walls (see Figure 14 and Figure 15).



Figure 13. Interior wall crack on the test home



Figure 14. No damage to the exterior walls of the test home: end wall



Figure 15. No damage to the exterior walls of the test home: side wall

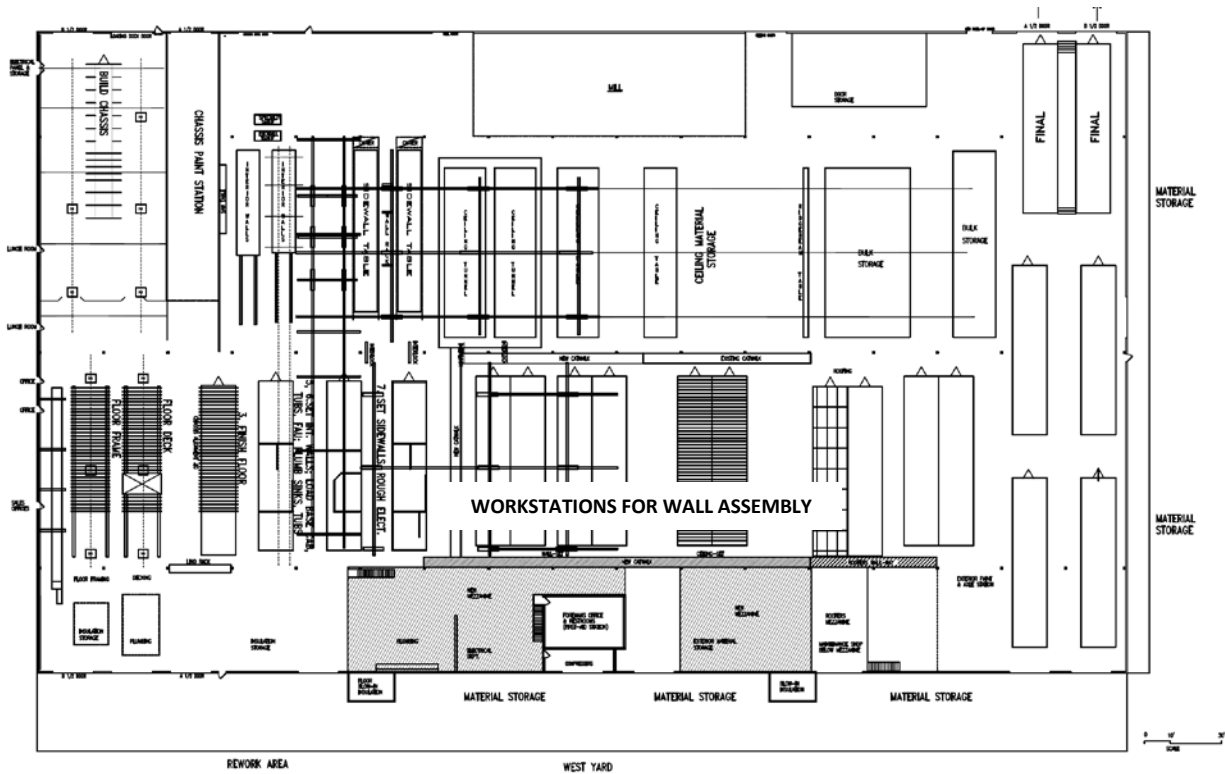
## **4.5 Manufacturing Process Analysis**

The manufacturing process was analyzed to develop a manufacturing strategy for “stud walls with continuous exterior insulation” that, by streamlining overall production, substantially reduces total cost. Karsten Homes, a manufactured home building plant in Sacramento, California, hosted the component demonstration build and full-scale whole-house prototyping of the selected wall design, and also served as the model for analyzing the production process. This section addresses and analyzes the construction process of a test home with CI on the exterior walls. To provide context, the baseline (current) process is also characterized. This allows needed process changes to be identified and their impacts on production performance to be estimated.

### **4.5.1 Baseline Process**

The baseline (current) manufacturing process at Karsten Homes was observed on October 2, 2013. The observation focused on activities that could be affected by the use of CI on the exterior walls. This includes all activities performed on the exterior of the walls: installation of weather resistant barrier, sheathing and/or siding, flashing, windows, doors, trim, and eave soffits; cutting out openings for exterior lights and receptacles; and painting the siding. These activities are performed in workstations 12–17 of the production line (see Figure 16).

The line is currently producing three floors per day, operating on a 2½-hour line cycle time. The exterior wall crew responsible for these activities consists of five workers. The crew typically divides into two teams of two workmen each, with each team performing all activities on every other floor as it moves through workstations 12 and 13. On an average, it takes each team 5 hours (two line cycles) to complete all exterior wall work on a given floor. The fifth member of the crew performs single-worker tasks for both teams, including painting, if needed. A separate crew of utility workers performs specialty tasks associated with more complex, custom designs. For example, the utility crew assists a team when their floor requires both exterior sheathing and siding, an infrequent design option at Karsten.



**Figure 16. Karsten plant layout**

#### 4.5.1.1 Description of Activities

The baseline activities affected most by the use of CI are the installation of house wrap, siding and flashing, and the cutting out of openings in the siding for windows and doors.

The house wrap is installed in two bands, by a two-worker team. First, a 3 ft wide lower band is installed around the base of the wall. Then a wider, overlapping upper band is installed to the eave. When installing the upper band, one worker works on a rolling scaffold, while the second works below on the factory floor. House wrap is unrolled, cut to size, positioned, tacked, and then permanently attached using a staple gun.

Siding is installed by a two-worker team using the following process:

1. Retrieve sheets of siding (4 ft × 9 ft) from a staging cart located near the end wall and stage against the walls.
2. Install a ledger board at the base of one end of the wall to place the first sheet.
3. Position the first sheet on the ledger board, tack and then permanently attach using a nail gun and finally reset every nail by a hammer. Note that the bottom edge of the sheet is not attached to allow flashing to be installed underneath at a later time. One worker works on a rolling scaffold, while the second works below on the factory floor.
4. Remove the ledger board after the first sheet is attached.
5. Follow the above steps to install the remaining sheets on the wall, one sheet at a time. Move the rolling scaffold and air hoses after every two sheets.

6. Measure the width needed for the last sheet, cut the sheet to size on the table, saw and install.

Siding may be installed differently on the end walls as follows:

- One worker may perform the activity.
- A single worker may use a ladder instead of a rolling scaffold, since it is easier to handle. It is also difficult to use a rolling scaffold to work on the end wall at the tongue end of the floor.
- Siding at both ends of an end wall may need to be cut to size to allow panel edges to fall on a stud.
- An additional (gable) band of siding is required on the end wall. A full height lower band of siding is installed first. Then measurements are taken at the gable, sheets are cut to size and installed.

Flashing is installed by a single worker using the following process:

1. Retrieve 10 ft long sections of metal flashing from the staging area and stage on the factory floor along the wall.
2. Position each section of flashing under the bottom of the siding and tack through the siding using a nail gun.
3. Complete attachment of siding and flashing using a nail gun.
4. Measure for the last section of flashing at the end of the wall, trim to size, and attach.

Openings for windows and doors are cut out of the siding by a single worker using the following process:

1. Locate openings from the interior by using a hammer to penetrate the siding near the center of each opening.
2. While standing on a rolling scaffold on the exterior, use a router to cut out each opening, using the framing as a guide.
3. Remove cutouts from the area and discard.
4. Attach siding to the frame around the opening with a nail gun.

#### ***4.5.1.2 Analysis of Observed Performance***

The following observations were made with regard to production efficacy:

- Exterior wall activities were performed safely. Personal safety equipment (safety glasses, hard hat) was worn by workers at all times. Power tools (staple/nail guns, router, table saw) were used responsibly and professionally. Rolling scaffolds provided safe access to the upper wall. Workers took shelter during overhead movement of material (shingles) and equipment (catwalks).

- Activities were performed with a high degree of precision/quality. No discrepancies or rework were observed.
- Activities were performed efficiently and within the required cycle time. The crew appeared well trained and maintained a brisk, yet sustainable work pace. There was little observed idle time. The organization of the crew into small, multi-worker teams helped ensure pacing with little lost time. Tools and equipment were job appropriate and located near their points of use. Siding was staged on a cart near the point of use.
- Interruptions in the area are frequent. Productivity is lost each time a worker is interrupted from his or her task. Time is lost beyond the legitimate interruption—it takes a while to get back on task, particularly for a single worker not working as part of a team. Interruptions observed included cutting siding to size, stopping for overhead material handling, moving to provide aisle access on the back end and assisting another worker.

Process time estimates for select activities are shown in Table 5. Estimates include all work on a 56 ft × 14 ft floor, except where otherwise noted. Note that estimates are based on very limited observation and, therefore, are only rough approximations.

**Table 5. Process Time Estimates for Select Baseline Activities**

<b>Activity</b>	<b>Clock Time (min.)</b>	<b>No. of Workers</b>	<b>Labor Hours</b>
<b>Install CI</b>	14	2	0.5
<b>Install Siding on Side Wall</b>	39	2	1.3
<b>Install Siding on One End Wall (Excluding Gable)</b>	33	1	0.5
<b>Install Flashing</b>	48	1	0.8
<b>Cut Out One Opening</b>	5	1	0.1

No idle time or delays in line movement were observed due to off-standard conditions (such as accidents, tool/equipment malfunctions, defects/rework, material unavailability, poor work pace, etc.). The layout of the area was logical and efficient.

Baseline production performance was, in general, very good. However, some possible opportunities for improvement were noted:

- Can a single band of CI be used on the side walls (instead of two)?
- It is difficult for a worker installing CI and siding on a scaffold to work under a catwalk. Can the catwalk be raised or moved while performing these activities?
- Is there an alternative to resetting every siding nail using a hammer?
- Is there an alternative to cutting siding on both ends of an end wall to size?

- Is it possible to improve flow by reducing unnecessary interruptions?
- Can a waste receptacle be located in the area for cutouts?

#### **4.5.2 Test Process**

The process for installing CI on the exterior walls of the test home was observed on October 3, 2013. In planning for the test, the use of CI was assumed to be well within the capabilities of the Karsten production system, which routinely produces highly customized homes. The flexibility of the production system—its ability to readily accommodate extra work—is supported by two core capabilities: (1) a well-staffed, highly experienced utility crew; and (2) ample workstations.

For example, Karsten typically produces homes with structural siding, which requires no sheathing. The exterior wall crew wraps the walls and installs siding in workstations 12 and 13 (see Figure 16). However, some Karsten designs require both sheathing and siding. For these atypical homes, the utility crew performs the extra work (installs sheathing). The two crews have workstations 12–17 to perform all activities on the exterior walls. In planning for the test, it was assumed that the CI could be successfully installed like other types of exterior sheathing on the Karsten line. The process test was observed to verify this assumption, document the extra work and other production challenges associated with the test home design, and identify design and process changes that might facilitate production of the new design.

##### **4.5.2.1 Description of Activities**

This section describes the changes observed in the baseline Karsten production process. Changes were observed in the following activities:

- Install house wrap (not required for the test home)
- Install additional 2 in. × 6 in. lumber along the eave, added as backer for trim detail
- Precut 6 in. strips of CI needed to cover full height of the side wall
- Install CI added layer of material
- Precut siding, reducing height to 102 in.
- Install siding, flashing, windows, doors, and trim over and fastened through the CI. Door trim requires different details.
- Cut out openings in the siding for windows and doors using a handheld circular saw instead of a router.

No house wrap was required in the test home. Instead, the CI, sealed at the joints with specialty tape, served as a weather barrier.

The basic design of the test home required no eave overhang. This design decision was not related to the use of CI. However, the use of CI did require the use of additional 2 in. × 6 in. lumber installed along the eave to provide backing for the eave trim above the CI and siding. The lumber was installed by one worker after roof set and before installation of the CI. Working on a ladder, the worker positioned each 2 in. × 6 in. piece, tacked it in place, and completed attachment using a nail gun. A handheld circular saw was used to cut the 2 in. × 6 in. at the end of the wall to size.



Use of 8 ft long sheets of CI on the 102 in. high wall required an additional 6 in. wide band of CI along the base of the side wall. These 6 in. strips of CI were precut in two steps: (1) retrieve sheets of CI from a pallet in the staging area; and (2) cut each sheet into 6 in. strips using the table saw.

Two teams, varying in size from one to four workers, simultaneously installed the CI on the two floors of the test home. The following process was used for the side walls:

1. Retrieve full size CI sheets and precut CI strips from the staging area and stage against the wall. As noted previously, shortly after the test started, the workers discovered that the CI sheets were wider than 48 in. (actually it varied from 48¼ in. to 48½ in.). Consequently, after a few CI sheets were installed, the edges no longer fell on a stud. A couple of workarounds were used to compensate for the panel production error. Typically on every second or third sheet, either a backer stud was added or the width of the CI sheet was trimmed (Figure 17).



**Figure 17. Trimming a CI board**

2. Position a full size CI sheet at the top of the wall (below the 2 in. × 6 in. lumber) and tack using a staple gun. When positioning at the end of the wall, be sure that the sheet is flush to the end of the wall framing, allowing a tight foam seal around the corner. Complete attachment using a staple gun. To perform this and the remaining tasks, one to two workers work on a rolling scaffold while one to two workers work below on the factory floor (Figure 18).
3. Position a precut CI strip below the full size sheet and tack using a staple gun. Complete attachment using a staple gun.



**Figure 18. Installing and tacking foam boards**

4. Tape the horizontal seam between the lower and upper bands of CI. Tape all vertical seams along the side and end walls and corner joints.
5. Caulk between the upper band of CI and the 2 in. × 6 in. lumber at the eave.
6. Cut out the CI from window and door openings using a router. Use the framing as a guide to attach the CI around each opening with the help of a staple gun.
7. Install the remaining CI along the length of the wall using the same procedure. Move the rolling scaffold, air lines and electrical cord after the installation of every two sheets.
8. Measure the width needed for the last pieces of foam at the end of the wall and cut the pieces to size on the table saw and install.

CI was installed differently on the end walls as follows:

1. One to two workers perform the activity. Higher work is performed on a ladder or rolling scaffold.
2. Full height sheets of CI are installed across the bottom of the wall. Then measurements are taken for the gable, and the foam is cut to size on the table saw, carried to the line, and installed (Figure 19).
3. The material is cut to size on both ends of the wall. The foam board must overhang each end by 1 in. to provide a tight foam seal around each corner. The other vertical edge must land on a stud.



**Figure 19. Installing CI at the gable**

4. The 9 ft long siding was precut to 102 in. to accommodate the eave detail on the side walls. Siding was cut to size (three sheets at a time) using a handheld circular saw directly on the staging cart.
5. Longer fasteners were required to install siding, flashing, windows, doors, and trim through the siding and CI and into the frame (Figure 20). This change did not noticeably affect the process.



**Figure 20. Siding installation**

Openings for window and doors were cut out of the siding by a single worker using the following process (Figure 21):

1. Locate openings from the interior by using a nail to penetrate the siding at each corner of each opening.
2. While standing on a ladder on the exterior, use a straight edge to outline the opening, using the nail holes as a guide.
3. Use a handheld circular saw to cut out each opening.
4. Remove cutouts from the area and discard.
5. Attach siding to the stud frame around the opening with a nail gun.



**Figure 21. Cutting out a window opening with a circular saw**

#### *4.5.2.2 Analysis of Observed Performance*

CI is inherently safe and easy to handle, cut-to-size, and install. The exterior wall activities observed during production of the test home were performed with comparable safety as the baseline process.

Quality suffered somewhat during production of the test home. Some rework was required:

- The first sheet of CI installed at the end of the sidewall was removed, repositioned, and reinstalled so that one vertical edge was flush to the end of the wall and the other edge was near the center of a stud.
- The first sheet of CI installed at the end of the end wall had to be recut so that one vertical edge was flush to the outside edge of the CI already installed on the sidewall and the other vertical edge was near the center of a stud.
- Not unlike the experience when using other wall sheathing materials, several sheets of CI needed to be recut for the gable. The cuts were complicated by the angles and a large louvered vent installed in the gable wall.

In addition, a small-scale mockup of the CI building system (prior to the test) revealed that a significant number of siding nails missed a stud or two of the 28 studs requiring fasteners (7%). The depth of the CI may make it harder to hit a stud as small errors in alignment are magnified with thicker material. It was not possible to observe nail misses for the baseline process or for the test home, since the walls were closed before siding was installed.

A number of factors contributed to the rework and reduced labor efficiency observed during the test:

- The workers lacked experience with CI installation. Although CI was installed on the mockup, all workers did not participate in the demonstration. The installation process was not well defined. The two teams were left to “discover” the best process and worker organization in real time. Various worker combinations were tried, including: two workers up (on the rolling scaffold) and two down (on the factory floor), two up and one down, and one up and one down (similar to siding installation). Both teams eventually evolved to two workers total, one up and one down.
- The dimensions of the CI sheets (48½ in. × 96 in. ), the only product size available for the prototyping, were not ideal for the application:
  - The wall height (102 in.) required a second 6 in. band of CI on the side walls. This required extra cutting, handling, positioning, fastening, and taping.
  - The extra width required a stud backer or cut every two to three sheets.
- The router bit was not ideal for the application. The cutting length was too short to cut through both the siding and foam in a single pass, while using the framing as a guide. This resulted in two separate cutouts for each opening, one for the foam and one for the siding. The foam cutting was easy, using a router with the framing as a guide. Cutting the siding was more difficult. It required outlining the opening (the framing could not be used as a guide) and using a handheld circular saw. This issue can be overcome with the use of a longer router bit that would enable cutting both the siding and the foam in a single pass.
- Process interruptions were much more frequent as workers struggled with an undefined process, unclear roles, and unfamiliar materials. This constantly disrupted the pace of the teams.

Process time estimates based on observations during production of the test home are shown in Table 6 below. Estimates include all work on one floor, except where otherwise noted. Where manpower varied greatly (e.g., the installation of CI on the sidewall), average manpower was estimated. Note that estimates are based on very limited observation and, therefore, are only rough approximations.

**Table 6. Process Time Estimates for Selected Test Activities**

Activity	Clock Time (min.)	No. of Workers	Labor Hours
Install 2 × 6 Along Eave	30	1	0.5
Cut 6 in. Foam Strips	5	1	0.1
Install Foam on Side Wall	67	3	3.3
Install Foam on One End Wall (Excluding Gable)	16	2	0.5
Cut Siding to 102 in.	10	1	0.2
Install Siding on Side Wall	40	2	1.3
Cut Out Siding From One Opening	5	1	0.1

Although longer fasteners were required to install the siding, flashing, windows, doors, and trim through the siding and foam and into the frame, this change did not significantly affect the process or the times observed. In fact, the time required to install siding on one sidewall was almost identical to that of the baseline process.

Estimates for the marginal labor required to build the test home are shown in Table 7 below.

**Table 7. Marginal Labor for the Test Home (Two Floors)**

Activity	Labor Hours		
	Test Home	Baseline	Margin
Install House Wrap	0.0	1.0	-1.0
Install 2 in. × 6 in. Lumber Along Eaves	1.0	0.0	1.0
Cut 6 in. CI Strips	0.2	0.0	0.2
Install Foam on Side Walls	6.7	0.0	6.7
Install Foam on End Walls (Excluding Gable)	1.1	0.0	1.1
Cut Siding to 102 in.	0.3	0.0	0.3
<b>Total</b>	<b>9.3</b>	<b>1.0</b>	<b>8.3</b>

The process issues discussed previously result in overstating the true marginal labor cost of installing CI in the test home. Note that once the foam installation teams worked through these issues and gained some experience, they evolved to two teams of two workmen each. By the end of the test, one team demonstrated that they could install the full size sheets of CI on an end wall (excluding the gable) at a pace equal to that of siding installation in the baseline case. Assuming that this is the true pace of CI installation, the true marginal labor of installing CI in the test

home is approximately **4.2 labor hours**. Note that this estimate excludes CI installation at the gables.

At a wrap-up meeting following the test, the research team reflecting on the process made the following observations and recommendations:

- A router bit with a longer cutter is needed sufficient to cut both the CI and the siding, while allowing the framing to serve as a guide.
- Getting CI supplied with the proper dimensions (e.g., 4 ft × 9 ft) is essential.
- Foam scraps (e.g., cutouts from window/door openings) should be used as spacers on the gables. Cutting to size for a tight fit is not required here, since the attic is not part of the conditioned space. A more comprehensive solution would be to redesign the roof to be 2 in. longer to eliminate CI at the gable.
- The existing door design worked for the front door of the test home with only minor changes to the trim detail. However, if there is not a perpendicular wall near the hinge side of the door (limiting the door swing beyond 90 degrees), the deeper opening may itself limit door swing. Note that the door is located to the exterior of the opening. A door designed for a 6 in. wall might be a better solution.
- The CI did not need to be fully fastened, since the siding nails also serve to fasten the CI. Instead, just tacking each corner of the CI sheets may suffice.
- With experience, the joint sealing tape can be applied efficiently and expeditiously, especially along vertical seams.
- From a housekeeping perspective, debris from cutting CI with a router requires additional cleanup.

In summary, the process test demonstrated that CI could be successfully installed on the test home in the Karsten factory with minimal disruption. However, several design and production factors may make installation more difficult generally.

- Installation of the foam requires extra labor—approximately 2 additional labor hours per floor (about one additional worker for a line producing three to four floors per day). If all homes required CI, installation could be a full time assignment for an additional worker. If CI is only an option, then this labor might better be provided by a general purpose utility crew responsible for customization/optional work.
- It may require an additional workstation available for exterior wall activities. CI installation is a serial task. It must be performed after sheathing is installed (if sheathing is required) and before the installation of windows, doors, and siding. Therefore, there must be sufficient workstations for an additional layer to be added to the exterior walls. This is often the case in housing factories where finished drywall is standard, since the interior requires more work than the exterior and, therefore, defines the length of the production cycle and length of the line. If there are not sufficient workstations, then it may be possible to install CI at the same station (in the same production cycle) as

sheathing or windows/doors. For example, the CI installer might closely follow the sheathing installers or be integrated into a single CI/sheathing team.

- If 2 in., R-10 CI is used, it will be progressively harder to hit the studs with a nail or screw gun.
- If sheathing, CI, and vinyl siding are all used, the design implications of installing windows and doors directly over the CI need to be considered.

#### **4.6 Cost Benefit Analysis**

The economic value of the wall design with CI was considered relative to two benchmarks: a typical wall as constructed by home manufacturers today that complies with the HUD standards; and, a wall design that conforms to the 2012 IECC prescriptive requirements but without CI. The latter case is an alternative for homes in IECC climate zone 5 only, where in lieu of using CI, builders can construct walls with 2 in. × 6 in. framing and R-21 insulation, commonly a high density batt insulation product. Therefore, the second case comparison was limited to climate zone 5 as the colder climates prescriptively require CI. A comparison of wall features is shown in Table 8.

Table 8 provides estimates of wall marginal costs relative to homes conforming to the HUD code (SS1 and MS1). The estimates are costs to the consumer and include all materials, labor, overhead, markups, and other related costs. Further, over time these costs are likely to decline as the plant gains experience with the CI materials and is able to leverage commodity pricing. The figures are shown for typical single-section and multi-section homes. The alternatives are compared with a single HUD design as, for the most part, the IECC climate zones 5, 6, and 7 are all subsumed in HUD code thermal zone 3.



**Table 8. Cost Analysis of Wall Options**

<b>Single Section</b>				
	<b>HUD Standard (Zone 3)</b>	<b>2012 IECC Standard Climate Zone 5</b>		<b>2012 IECC Standard Climate Zones 6 and 7</b>
<b>Identifier</b>	SS1	SS2	SS3	SS4
<b>Description</b>	Current HUD minimum	High performance wall without CI	High performance wall with CI	High performance wall with CI
<b>Framing</b>	2 × 4 @ 16 in. o.c.	2 × 6 @ 16 in. o.c.	2 × 4 @ 16 in. o.c.	2 × 6 @ 16 in. o.c.
<b>Cavity Insulation</b>	R-13	R-21 (HD)	R-13	R-21 (HD)
<b>Exterior Insulation</b>	None	None	R-5	R-5
<b>U<sub>wall</sub>-Value</b>	0.075	0.051	0.054	0.040
<b>Marginal Cost (\$/Home)</b>	–	\$398	\$649	\$882
<b>Multi-Section</b>				
<b>Identifier</b>	MS1	MS2	MS3	MS4
<b>Description</b>	Current HUD minimum	High performance wall without CI	High performance wall with CI	High performance wall with CI
<b>Framing</b>	2 × 4 @ 16 in. o.c.	2 × 6 @ 16 in. o.c.	2 × 4 @ 16 in. o.c.	2 × 6 @ 16 in. o.c.
<b>Cavity Insulation</b>	R-13	R-21 (HD)	R-13	R-21 (HD)
<b>Exterior Insulation</b>	None	None	R-5	R-5
<b>U<sub>wall</sub>-Value</b>	0.077	0.053	0.054	0.040
<b>Marginal Cost (\$/Home)</b>	–	\$398	\$612	\$837

The cost analysis addresses the following questions:

- What changes would be required for manufacturers building homes today for HUD thermal zone 3 to meet the prescriptive wall thermal requirements of the 2012 IECC and at what additional cost?
- From a life cycle cost perspective, are the marginal costs justified by the energy savings benefits?
- For homes in IECC climate zone 5, is the CI case (SS3 and MS3) more or less cost effective than the design without CI (SS2 and MS2)?

Cases 3 and 4 include CI so the answers to the above questions address the cost effectiveness of adding exterior insulation. Comparing cases 2 and 3 on the same economic basis addresses another key question:

- In building homes to the requirements of IECC climate zone 5, is a wall solution with CI more or less cost effective than a standard frame and batt design without CI?

The marginal wall construction costs shown in Table 8 suggest that meeting the 2012 IECC standards for manufactured home builders will engender a higher retail cost ranging from about \$400 for homes in IECC climate zone 5 to more than \$800 in zones 6 and 7. In the former case, the major cost contributors are moving from 2 in. × 4 in. to 2 in. × 6 in. framing and using a high density 6 in. batt compared with an average density fiberglass batt. The marginal costs of the CI cases 3 and 4 are in large part driven by the expense of CI.

Worth noting is the higher  $U_{\text{wall}}$ -value for the CI wall compared with the standard frame, non-CI wall indicating that, at least from a thermal transmittance standpoint, the CI option is slightly less efficient. However, it should be noted that CI provides additional building performance advantages (e.g., continuous weather barrier) and an important thermal advantage: the continuous skin and sealed joints will reduce whole house leakage rates.

The magnitude of the impact of CI on infiltration rates and therefore energy savings is an important determinant of relative cost-benefit of these two options. In projecting energy savings, it was assumed that a home without CI has an infiltration rate of 7.4 ACH50.<sup>6</sup> The addition of CI is projected to reduce this figure to 3.7 ACH50. The resulting energy savings are shown in Table 9 for representative locations<sup>7</sup> in the three IECC climate zones and for single- and multi-section homes heated with gas and electric furnaces. Comparisons are relative HUD minimum code homes in those locations.

---

<sup>6</sup> There are limited data supporting the assumed reduction in infiltration rate associated with applying a CI to the exterior walls. Future research is planned to better quantify the impact of CI on leakage rates.

<sup>7</sup> Locations used for analysis were: region 5–Lancaster, Pennsylvania; region 6–Madison, Wisconsin; region 7–Great Falls, Minnesota.

**Table 9. Marginal Energy Savings Compared With Base Case (\$/Year)**

IECC Climate Zone	Energy Type	Single-Section		Multi-Section	
		High Performance Wall Without CI	High Performance Wall With CI <sup>8</sup>	High Performance Wall Without CI	High Performance Wall With CI
5	Gas	\$75	\$105	\$74	\$117
	Electric	\$169	\$235	\$162	\$265
6	Gas		\$225		\$247
	Electric		\$514		\$563
7	Gas		\$235		\$256
	Electric		\$556		\$605

Table 10 expresses the costs and savings on a life cycle cost basis over a 30-year time frame. Note that all results are positive figures indicating that the wall improvements, CI and non-CI, are cost effective relative to current HUD code requirements. As expected the benefits are greater for electrically heated homes compared with gas-heated homes and the magnitude of the net benefits increases as the climate gets colder, despite the higher marginal cost of these measures. The walls with CI are also, in all instances, more cost effective than the wall without CI. However, as noted earlier, the economic advantage over the high performance wall without CI is due entirely to the assumed reduction in air infiltration.

**Table 10. LCC Analysis, 30-Year Time Horizon**

IECC Climate Zone	Energy Type	Single-Section		Multi-Section	
		High Performance Wall Without CI	High Performance Wall With CI	High Performance Wall Without CI	High Performance Wall With CI
5	Gas	\$1,687	\$2,236	\$1,657	\$2,660
	Electric	\$4,508	\$6,153	\$4,306	\$7,080
6	Gas		\$5,530		\$6,228
	Electric		\$14,200		\$15,715
7	Gas		\$5,831		\$6,512
	Electric		\$15,456		\$16,978

With the economic value of CI partly predicated on how the product impacts infiltration rates field testing is warranted and in the months ahead the ARIES team is planning on conducting comparative tests of manufactured homes with and without CI. On paper, at least, the benefits of making significant improvements in wall thermal performance are compelling, given the industry’s ability to implement these measures at a relatively modest cost.

<sup>8</sup> The marginal energy savings for the high performance continuous insulation case assumes a reduction in infiltration rate to 3.7ACH50 from 7.4 ACH50 for the wall designs without the continuous insulation.

## 5 Discussion

The current phase of the research enabled the team to assess the ramifications of using CI in the production of a homes constructed under the HUD manufactured housing standards. The mockup and full-scale prototyping work were instruments for investigating several factors as they relate to the viability of the technology and perfecting its use in a factory setting including: best practices for construction detailing and related tools and techniques of manufacture; compliance with the HUD standards; construction durability particularly with regard to fastener integrity; cost effectiveness; production sequencing, integration into plant flow, and material handling and storage; and plant staff training.

On critically important levels the prototyping was a success. Within a few days, a plant with no prior experience with CI was able to work with the product, folding it into the production process with only a few stumbling blocks that were or will be readily resolved with minor changes in how the product is used. Using CI raises costs, both material and labor, albeit the increase is fully cost justified by the savings when viewed from a life cycle cost perspective. While first cost increases negatively impact market uptake, there is reason to expect that the marginal cost increase will be moderated as industry gains familiarity with using CI and a combination of market demand and changes in building standards help narrow the cost divide.

### 5.1 Whole-Building System Integration

The use of CI introduces several potential whole-building system integration issues, some of which were examined in the current work or will be evaluated in the next phase of the research. The main interaction factors discussed in this report are as follows:

- **Cost performance:** CI was considered against current building practice and an alternative practice of roughly equivalent thermal impact but using frame and batt construction. The CI case is more costly than either option but more cost effective over a life cycle cost time horizon. The research suggested that the marginal cost difference is likely to be reduced over time making CI even more attractive.
- **Building durability:** A visual inspection of the home following transport to a customer's site several hundred miles from the manufacturing plant suggested that CI has no evident negative impact on building integrity. More observation and evaluation are needed, particularly with regard to long-term moisture-related performance and building durability.
- **Production speed:** While the focus is mainly on the systems interactions within the building itself, the use of CI technology impinges on (interacts with) the construction process, specifically by potentially influencing the rate of plant throughput. The current phase sought to measure this impact and came to the general conclusion that CI can be added to the production line with a modest and tolerable increase in cycle time.
- **Equipment capacity and performance:** Like other efficiency measures, by improving the thermal envelope, CI will help reduce loads and potential lead to reduced equipment capacities. The actual impact varies by climate, equipment type, and the specified insulation level.

- **Indoor air quality:** It is well established that manufactured homes tend to have low infiltration rates due partly to the pervasive use of foam sealants on roof and wall joints and quality associated with plant production. CI is likely to lower infiltration rates further but, if and to what extent the reduction impacts air quality is an important subject for exploration (see Section 6).

## 5.2 Identification of Barriers to Market Acceptance

The normal conservatism of the housing market provides resistance to most new building methods and technologies, particularly one whose benefits are conceptual (energy savings) and physically concealed (behind the walls). What follows is a brief narrative describing the various audiences whose reactions to CI will together determine market acceptance and some initial thoughts on how each is likely to view the technology.

- **Home manufacturers:** Home manufacturers form the first line of resistance against changes in building practice, and their key concerns are slowing production and increasing cost. Use of CI does both. However, there are reasons to expect that opposition to CI among many or most plants will be tepid and over time CI will emerge as a superior technology based on the following: the market will increase in demand for greater energy efficiency; CI can be added to production without the need for major change in the factory building process; CI is cost-effective relative to the alternatives, a fact that companies can use as a selling point; there are no code barriers to its use; and CI is a mature technology that is familiar in most housing markets across the nation.
- **Home retailers:** Retailers will need to understand and articulate to customers the benefits of CI. This will require outreach to the retailers on the part of the manufacturers. In general, this is a slow process but not likely to be a stumbling block to rolling out the technology. Further, CI can be positioned in the market as a superior, positive attribute that aids in the sales process.
- **Manufactured homebuyers:** If sold as an option, CI faces a hurdle with homebuyers, particularly if the sales proposition pits CI against other optional features, particularly those that are visible and/or utilitarian. How other advantages can be brought to bear on the purchase decision, such as information showing the economic benefits of CI, loan terms that favor efficiency investments, etc., will in the short run determine homebuyer acceptance.

## 6 Conclusion and Next Steps

The research described in this report is part of a multiphase program with the goal of identifying and moving toward commercial acceptance of envelope construction methods that are far more efficient than current practice and specifically geared to meet the needs of factory builders. The current effort is focused on wall component development, prototyping, and testing. Work in this phase primarily involved building a mockup wall to identify and resolve fabrication and production challenges and building a full-scale home using the CI design to better understand related production issues.

The team convened at the Karsten Homes manufacturing facility in Sacramento, California to conduct the tests. All of the important stakeholders participated, including: plant management and production staff, members of the Technical Steering Committee, representatives of related product suppliers and the ARIES technical team. Working from a test plan, the group reviewed and refined plans for the 2 days of building, observation, and testing. On the first day, a mockup wall section was constructed. On the second day, a home on the line was sheathed with CI. At the end of each day, the group convened to discuss and review the joint findings. From this experience and subsequent analysis of the results, the team concluded the following:

- CI material can be used on the production line in a manner similar to other types of exterior sheathing (such as OSB) and without major drawbacks. Product low weight is an advantage from a handling standpoint. Application of CI adds a few hours to cycle time but more experience with the material is likely to reduce this figure. Better and inexpensive tools, such as an appropriate tape dispenser and a long router bit, would further expedite material installation and improve quality.
- The use of CI in the factory environment is allowed by the HUD standards (without the need for an Alternative Construction letter) provided the material meets required perm ratings (location dependent) and structural limits (minimum 25 psi).
- The currently available material specifications need to be broadened to better meet the needs of factory builders. Of concern is the ability of vendors to deliver on a just-in-time basis, with material that is at least 4 ft wide × 9 ft high. Material marked with stud locations would speed production and improve quality. One inch material thickness is the current limit both from standards and product performance perspectives.
- The higher costs of a CI wall solution will initially be a drag on market penetration but mainly for highly price-sensitive homes. Manufacturers in colder climates and with higher price point homes (e.g., California, Midwest, Northeast, Northwest) are likely to be the first to fully embrace CI. The product is highly cost effective enabling early users to frame CI with a compelling market message.

The current work identified four remaining technical issues for investigation. These will be addressed as part of the next phase of the research through fielding testing of three side-by-side homes. The homes will be instrumented and monitored for at least a full heating and cooling season. The issues are as follows:

- 1. Moisture testing.** Concerns about moisture conditions within walls using CI need to be settled. Two of the three test homes will be built with CI and humidity levels monitored in all walls.
- 2. Infiltration rates.** Whole-house infiltration rates will be measured for the three homes. While the results will be anecdotal, the data will begin to provide insight into the magnitude of the impact CI can have on infiltration rates.
- 3. Whole-house systems integration.** The impact of building with CI on other building systems, notably whole-house ventilation and equipment capacity and distribution, will be examined in greater depth.
- 4. Production efficiency.** The lessons learned in Sacramento will be applied to the fabrication of the three test homes and the impact on production efficiency will be studied.

## 7 References

ASTM E564 — Standard Practice for Static Load Test for Shear Resistance of Framed Walls for Buildings, published by ASTM International, [www.astm.org](http://www.astm.org).

ASTM E72-80 — Standard Test Methods of Conducting Strength Tests of Panels for Building Construction, published by ASTM International, [www.astm.org](http://www.astm.org).

HUD. U.S. (1994). *Manufactured Housing Construction and Safety Standards*, Subpart 3280. Washington, D.C.: U.S. Department of Housing and Urban Development.

Levy, E.; Mullens, M.; Tompos, E.; Kessler, B.; Rath, P. (2012a). *Building America Expert Meeting Report: Advanced Envelope Research for Factory Built Housing*. Golden, CO: National Renewable Energy Laboratory. NREL/SR-5500-54439.

Levy, E.; Mullens, M.; Kessler, B.; Rath, P. (2012b). *Building America Technical Report: Advanced Envelope Research for Factory Built Housing*. Golden, CO: National Renewable Energy Laboratory.

Levy, E.; Mullens, M.; Kessler, B.; Rath, P. (2014). *Advanced Envelope Research for Factory Built Housing, Phase 3 – Design Development and Prototyping*. Golden, CO: National Renewable Energy Laboratory. NREL/SR-5500-60704



## Appendix

### Equipment and Material Needs

The section provides details on the equipment and material needs for the mockup demonstration and whole-house prototyping.

**Table 11. Equipment and Material Needs**

Item	Description	Product Code	Quantity
<b>Materials</b>			
Foamular	1-in. R-5 Foamular F250 XPS	TBD	60 sheets
Joint SealR foam joint tape	Water resistive and air barrier; self-adhering seam tape	TBD	20 Rolls
FlashSealR flashing tape	Self-adhering flashing tape around door and window openings	TBD	20 Rolls
<b>Siding</b>			
7/16 in. SmartSide panel siding	4 ft × 8 ft 8 in. o.c.	As required	
<b>Fasteners</b>			
Staples (Insulation fastener)	2 in. × 1 in. crown, 16 gauge Staple	P21BAB	20,000 (4 cartons of 5000 each)
Nails (Siding fastener)	3 in. × 0.120 RS Nail	H627ASBX	15,000 (6 cartons of 2500 each)
<b>Fastening tools</b>			
Stapling guns	WC200 XP – 16 gauge, 1 in. wide crown, 2 in. heavy wire stapler	4Y0001N	5
Nailing guns	SN951XP – 4 in. 34 clipped head framing nailer	5B0001N	5

## Code Compliance Report



**RESOURCES  
APPLICATIONS,  
DESIGNS &  
CONTROLS, INC.**

September 16, 2013

Mr. Emanuel Levy, RA  
The Levy Partnership  
1776 Broadway, Suite 2205  
New York, NY 10019

3220 E. 59TH STREET  
LONG BEACH, CA 90805  
Tel (562) 272-7231  
Fax (562) 529-7513  
[www.RADCOinc.com](http://www.RADCOinc.com)  
Email: [info@RADCOinc.com](mailto:info@RADCOinc.com)

Re: Advanced Envelope Research for Manufactured Housing

Based on your request, RADCO has performed this research to identify the necessary requirements or testing needed to qualify the material XPS insulation (Foamular), for use in the wall construction of manufactured home, under the Manufactured Home Construction and Safety Standards.

Based on the data and details provided to RADCO and on the HUD Interpretative Bulletin C-5-76, we found that the XPS insulation Foamular material can be used in exterior wall construction of manufactured homes if it meets the following criteria:

- 1- The Extruded expanded polystyrene foam plastic material is **not to exceed 1" in thickness**, it can be used in the cavity of walls or ceilings as sheathing or backer board for exterior coverings when it meets the following conditions:
  - (i) The sheathing shall have a minimum compression strength of 25 psi when tested as per ASTM-D 1621-64 and an average thermal conductivity (k factor) of 0.20 BTU-in/hr ft 5 degree F at 75 degree F mean when tested as per ASTM-C-518-70
  - (ii) A minimum of two inches of mineral fiber insulation is provided within the wall cavity and a minimum of four inches of mineral fiber insulation is provided in the ceiling cavity (in ceiling application).
  - (iii) An interior finish material is provided on exterior wall and ceiling surfaces with equivalent fire resistive properties to 5/16" gypsum board.
  - (iv) A wall framing system consisting of 2" X 4" studs at 16" o.c. or equivalent when the sheathing is installed within the wall cavity.
  - (v) (For ceiling application), A roof framing system consisting of roof trusses or equivalent framing members installed at a min. spacing of 16" o.c.
  - (vi) The sheathing shall not be placed in contact with heat sources such as chimneys, heater vents or other surfaces which provide long term exposure to temperatures above 150 degree F. Clearance from the sheathing to the heat source shall be provided in accordance with NFPA 89M, heat producing appliance clearances.
  - (vii) A vapor barrier is provided on the warm side of the wall and ceiling cavity in accordance with Subpart F of the Manufactured Home Construction and Safety Standards.
  - (viii) The sheathing is installed in accordance with the manufacturer's installation instructions, including the provision for controlling joint locations by either the use of tongue and groove sheathing or by placement of joints over structural framing members.

In addition to all of the above requirements, the following is also needed in general:

- 1- The XPS insulation (Foamular) should have a flame spread rating of 75 or less and a smoke-developed rating of 450 or less (not including outer covering of sheathing).
- 2- If the XPS insulation (Foamular) and siding are used to replace structural sheathing required for transportation, a transportation test needs to be done to prove the integrity of the wall construction during transportation. However, if the home in question is approved to be built w/o structural sheathing no transportation test should be required unless other elements of the design have changed.

- 3- The design is only to be used in wind zone 1.
- 4- The fastening of the XPS insulation (Foamular) material to the framing members is to follow the manufacturer's installation instructions.
- 5- Also the fastening of the siding material to the framing members need to be identified (it has to be per the manufacturer's installation instructions).
- 6- Heat loss calculation has to be prepared for the envelope to meet the Manufactured Home Construction and Safety Standards.
- 7- If the construction is intended for WZ 2 & 3, each of the manufactured home wind resisting parts including but not limited to shear walls and their fastening and anchoring systems, cladding materials such as siding, exterior sheathing, wall studs, exterior glazing and their connections and fasteners have to be designed by a professional engineer or architect to resist (A) The design wind loads for Exposure C specified in ANSI/ASCE 7-88, "Minimum Design Loads for Buildings and Other Structures," for a fifty-year recurrence interval, and a design wind speed of 100 mph, as specified for Wind Zone II, or 110 mph, as specified for Wind Zone III (Basic Wind Zone Map); or (B) The wind pressures specified in the table provided in the Manufactured Home Construction and Safety Standards.

**If the Extruded expanded polystyrene foam plastic material exceeds 1" in thickness, then:**

The foam plastic insulating material has to be tested as required for its location in wall and/or ceiling cavities in accordance with testing procedures described in the Illinois Institute of Technology Research Institute (IIT) Report, "Development of Mobile Home Fire Test Methods to Judge the Fire-Safe Performance of Foam Plastic Sheathing and Cavity Insulation, IITRI Fire and Safety Research Project J-6461, 1979" or other full-scale fire tests accepted by HUD, and it is installed in a manner consistent with the way the material was installed in the foam plastic test module. The materials must be capable of meeting the following acceptance criteria required for their location:

(i) Wall assemblies. The foam plastic system shall demonstrate equivalent or superior performance to the control module as determined by:

(A) Time to reach flashover (600 °C in the upper part of the room);

(B) Time to reach an oxygen (O<sub>2</sub>) level of 14% (rate of O<sub>2</sub> depletion), a carbon monoxide (CO) level of 1%, a carbon dioxide (CO<sub>2</sub>) level of 6%, and a smoke level of 0.26 optical density/meter measured at 5 feet high in the doorway; and

(C) Rate of change concentration for O<sub>2</sub>, CO, CO<sub>2</sub> and smoke measured 3 inches below the top of the doorway.

(ii) Ceiling assemblies. A minimum of three valid tests of the foam plastic system and one valid test of the control module shall be evaluated to determine if the foam plastic system demonstrates equivalent or superior performance to the control module. Individual factors to be evaluated include intensity of cavity fire (temperature-time) and post-test damage.

(iii) Post-test damage assessment for wall and ceiling assemblies. The overall performance of each total system shall also be evaluated in determining the acceptability of a particular foam plastic insulating material.

(b) All foam plastic thermal insulating materials used in manufactured housing shall have a flame spread rating of 75 or less (not including outer covering or sheathing) and a maximum smoke-developed rating of 450.

This concludes our research. Should you have any questions, please do not hesitate to contact the undersigned.

Sincerely  
**RADCO**



Michael L. Ziemann, P.E.  
President



Hala Jawad  
Director Plan Review Services

*buildingamerica.gov*

U.S. DEPARTMENT OF  
**ENERGY**

Energy Efficiency &  
Renewable Energy

DOE/GO-102014-4404 • April 2014

Printed with a renewable-source ink on paper containing at least 50% wastepaper, including 10% post-consumer waste.