

Power System Planning: Emerging Practices Suitable for Evaluating the Impact of High-Penetration Photovoltaics

J. Bebic
GE Global Research
Niskayuna, New York

Subcontract Report
NREL/SR-581-42297
February 2008

NREL is operated by Midwest Research Institute • Battelle Contract No. DE-AC36-99-GO10337



Power System Planning: Emerging Practices Suitable for Evaluating the Impact of High-Penetration Photovoltaics

J. Bebic
GE Global Research
Niskayuna, New York

NREL Technical Monitor: Ben Kroposki
Prepared under Subcontract No. ADC-7-77032-01

Subcontract Report
NREL/SR-581-42297
February 2008

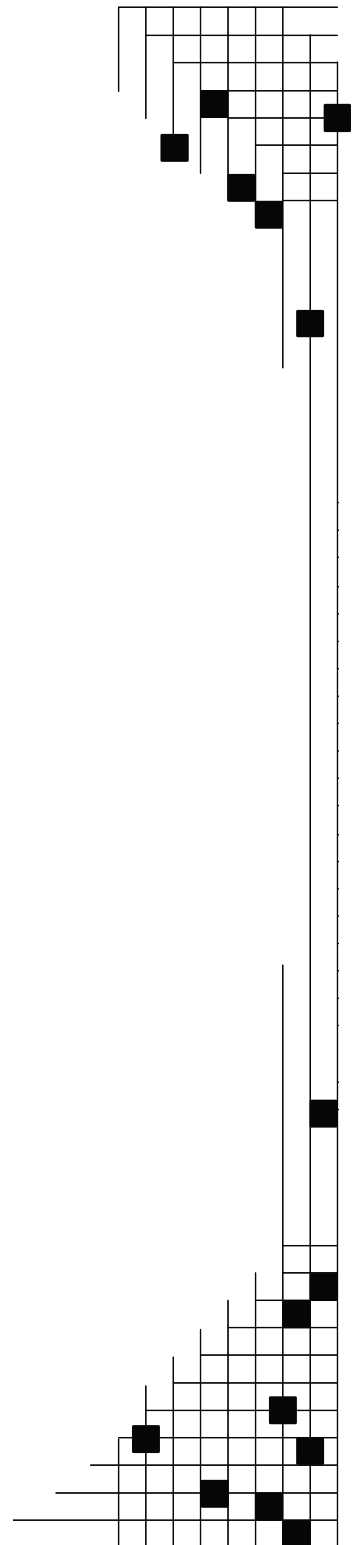

National Renewable Energy Laboratory
1617 Cole Boulevard, Golden, Colorado 80401-3393
303-275-3000 • www.nrel.gov

Operated for the U.S. Department of Energy
Office of Energy Efficiency and Renewable Energy
by Midwest Research Institute • Battelle

Contract No. DE-AC36-99-GO10337

NOTICE

This report was prepared as an account of work sponsored by an agency of the United States government. Neither the United States government nor any agency thereof, nor any of their employees, makes any warranty, express or implied, or assumes any legal liability or responsibility for the accuracy, completeness, or usefulness of any information, apparatus, product, or process disclosed, or represents that its use would not infringe privately owned rights. Reference herein to any specific commercial product, process, or service by trade name, trademark, manufacturer, or otherwise does not necessarily constitute or imply its endorsement, recommendation, or favoring by the United States government or any agency thereof. The views and opinions of authors expressed herein do not necessarily state or reflect those of the United States government or any agency thereof.

Available electronically at <http://www.osti.gov/bridge>

Available for a processing fee to U.S. Department of Energy and its contractors, in paper, from:

U.S. Department of Energy
Office of Scientific and Technical Information
P.O. Box 62
Oak Ridge, TN 37831-0062
phone: 865.576.8401
fax: 865.576.5728
email: <mailto:reports@adonis.osti.gov>

Available for sale to the public, in paper, from:

U.S. Department of Commerce
National Technical Information Service
5285 Port Royal Road
Springfield, VA 22161
phone: 800.553.6847
fax: 703.605.6900
email: orders@ntis.fedworld.gov
online ordering: <http://www.ntis.gov/ordering.htm>

This publication received minimal editorial review at NREL



Printed on paper containing at least 50% wastepaper, including 20% postconsumer waste

Preface

Now is the time to plan for the integration of significant quantities of distributed renewable energy into the electricity grid. Concerns about climate change, the adoption of state-level renewable portfolio standards and incentives, and accelerated cost reductions are driving steep growth in U.S. renewable energy technologies. The number of distributed solar photovoltaic (PV) installations, in particular, is growing rapidly. As distributed PV and other renewable energy technologies mature, they can provide a significant share of our nation's electricity demand. However, as their market share grows, concerns about potential impacts on the stability and operation of the electricity grid may create barriers to their future expansion.

To facilitate more extensive adoption of renewable distributed electric generation, the U.S. Department of Energy launched the Renewable Systems Interconnection (RSI) study during the spring of 2007. This study addresses the technical and analytical challenges that must be addressed to enable high penetration levels of distributed renewable energy technologies. Because integration-related issues at the distribution system are likely to emerge first for PV technology, the RSI study focuses on this area. A key goal of the RSI study is to identify the research and development needed to build the foundation for a high-penetration renewable energy future while enhancing the operation of the electricity grid.

The RSI study consists of 15 reports that address a variety of issues related to distributed systems technology development; advanced distribution systems integration; system-level tests and demonstrations; technical and market analysis; resource assessment; and codes, standards, and regulatory implementation. The RSI reports are:

- *Renewable Systems Interconnection: Executive Summary*
- *Distributed Photovoltaic Systems Design and Technology Requirements*
- *Advanced Grid Planning and Operation*
- *Utility Models, Analysis, and Simulation Tools*
- *Cyber Security Analysis*
- *Power System Planning: Emerging Practices Suitable for Evaluating the Impact of High-Penetration Photovoltaics*
- *Distribution System Voltage Performance Analysis for High-Penetration Photovoltaics*
- *Enhanced Reliability of Photovoltaic Systems with Energy Storage and Controls*
- *Transmission System Performance Analysis for High-Penetration Photovoltaics*
- *Solar Resource Assessment*
- *Test and Demonstration Program Definition*
- *Photovoltaics Value Analysis*
- *Photovoltaics Business Models*

- *Production Cost Modeling for High Levels of Photovoltaic Penetration*
- *Rooftop Photovoltaics Market Penetration Scenarios.*

Addressing grid-integration issues is a necessary prerequisite for the long-term viability of the distributed renewable energy industry, in general, and the distributed PV industry, in particular. The RSI study is one step on this path. The Department of Energy is also working with stakeholders to develop a research and development plan aimed at making this vision a reality.

Acknowledgments

The help and support from Power Systems Energy Consulting of GE Energy are greatly appreciated. Nicholas Miller provided insights into transmission system planning and operating practices; Gary Jordan helped address the interaction of high-penetration PV with generation planning, production scheduling, and power markets; and Reigh Walling helped review the impact of high penetration of solar PV on the distribution system. It has been a pleasure and a source of inspiration to work with these experts.

Executive Summary

This report explores the impact of high-penetration renewable generation on electric power system planning methodologies, and outlines how these methodologies are evolving to enable effective integration of variable-output renewable generation sources. All three areas of system planning are considered—generation, transmission, and distribution—and the impact of high penetration of solar PV analyzed relative to each.

Generation planning is shifting from planning for peak load towards planning for system energy. This shift is centered on using net load as a basis for capacity planning and this creates a set of requirements for reliable and comprehensive renewable resource data. Furthermore, a new dimension is being introduced into generation planning—the need for explicit evaluation of generation flexibility relative to the variability of net load at the time scale of load following. Increased penetration of intermittent renewable generation means that the operational flexibility of the balance of generation portfolio will become strategically important—the lack of flexibility inevitably will result in curtailment of renewable generation. To avoid this, more flexibility must be provided. Such flexibility can be achieved in three essential ways: balancing the generation portfolio, load control, and energy storage. This process can be accelerated by targeted R&D investment, and by creation of efficient markets to address future load-following needs. Quantifying the variability to determine required flexibility also requires correlated historic load and resource data at the time scales that currently are not being collected. Integration of renewable-resource data into generation planning is an important area of future work.

Transmission planning practices can readily include renewable generation, but significant effort is required to develop models that adequately represent distributed solar PV generation at the time scales of interest for transmission planning. Standardized modeling guidelines and test cases are required to facilitate harmonization of various software tools, and to prevent confusion and unwarranted concerns that will arise as a result of inconsistent—and possibly inaccurate—modeling.

Distribution planning and engineering practices already incorporate processes that allow connection of distributed generation. These processes were developed for integrating cogeneration and are not optimized for integration of small, distributed sources of power, such as solar PV. Currently, this results in unnecessary administrative and engineering hurdles that could be eliminated by dedicated, comprehensive, and coordinated treatment of solar PV installation in all relevant codes and standards. Remaining technical hurdles are possible to predict through careful analysis (simulation), but the analysis software should be harmonized with respect to the representation of PV inverters, the impact inverters have on feeder voltage, and their contribution to fault currents. Developing a set of test cases and modeling guidelines to enable benchmarking the software and the models can accelerate this process. Funding field installations and showcasing simple and effective solutions also would help build confidence within the industry.

When the penetration levels increase to a point of becoming a significant source of energy in the electric power system, communications links between system control centers and distributed PV sources will be helpful—and even necessary. This

communication infrastructure, assuming that it has ample capacity, can be leveraged in many different ways. It also would create opportunities for more-effective distribution system management, more-flexible system configurations, faster restoration, more-selective protection, efficient deployment of demand response, efficient implementation of real-time metering, introduction of flexible and creative electricity tariffs, and likely for many other applications. The main impediments to deployment of this communication infrastructure are its significant cost and the uncertainty that the benefits it provides will justify the required capital investment. With high-speed communications already bringing Internet service to many homes, sizable pilot programs relying on Internet infrastructure can be created to help evaluate the benefits and to guide design decisions for creating a dedicated infrastructure.

Table of Contents

1.0. Introduction	1
2.0. Traditional Practices in Power System Planning	3
2.1. Generation Planning.....	3
2.1.1. Load Forecasting.....	3
2.1.2. Relationship Between Capacity Reserves and Reliability.....	4
2.1.3. Capacity Resource Planning.....	5
2.2. Transmission Planning.....	7
2.2.1. Rotor-Angle Stability.....	8
2.2.2. Voltage Stability.....	9
2.2.3. Frequency Stability.....	9
2.3. Distribution System Planning.....	9
2.3.1. Load Forecasting.....	10
2.3.2. Planning for Reliability.....	10
2.3.3. Distribution System Engineering.....	10
3.0. Project Approach	11
4.0. Impact of High-Penetration Solar PV on Power System Planning	12
4.1. Impact of Variable Renewable Energy Generation.....	12
4.2. Implications on Generation Planning.....	13
4.2.1. Capacity.....	13
4.2.2. Characterizing the Net Load.....	14
4.2.3. Characterizing the Impact on Fuel Mix.....	17
4.2.4. Generation Flexibility.....	18
4.3. Implications for Transmission Planning.....	21
4.3.1. Common Characteristics of PV Inverters.....	21
4.3.2. PV Inverters' Behavior During Grid Faults.....	22
4.3.3. Modeling PV Inverters for Transmission Planning.....	23
4.4. Implications for Distribution Planning and Engineering.....	24
4.4.1. Feeder Voltage Regulation.....	24
4.4.2. Contributions to Fault Currents and Protection Desensitization.....	24
4.4.3. Ungrounded Source of Voltage.....	24
4.4.4. Software Tools Used in Distribution Engineering.....	25
5.0. Conclusions and Recommendations	26
5.1. Generation Planning.....	26
5.1.1. Capacity.....	26
5.1.2. Flexibility.....	26
5.2. Transmission Planning.....	27
5.3. Distribution System Planning.....	28
5.4. General Recommendations.....	29
6.0. References	30

List of Figures

Figure 1.	Least-cost generation planning (adopted from Stoll 1989).....	7
Figure 2.	Traditional and emerging practice in capacity planning.....	14
Figure 3.	System load, PV generation, and net load (CAISO July 2007).....	15
Figure 4.	Load duration curves, load and net load with 10%, 30%, and 50% PV penetration (CAISO July 2007)	16
Figure 5.	Dispatch order for 30% PV penetration, assuming California fuel mix (CAISO July 2007)	17
Figure 6.	Dispatch order for 30% PV penetration, assuming U.S. fuel mix (CAISO July 2007).....	18
Figure 7.	Control area and layers of frequency control (values typical).....	19
Figure 8.	An illustrative PV inverter topology.....	21
Figure 9.	An example voltage current and voltage power characteristic of solar module.....	22

List of Tables

Table 1.	Typically Reported Distribution Reliability Indices (IEEE 1366)	10
----------	---	----

1.0 Introduction

Recent cost reductions and the increases in production of solar photovoltaics (PV) are driving dramatic growth in domestic PV system installations. Programs such as Solar America Initiative are setting out to make solar energy cost-competitive with central generation by the year 2015. As the costs decline, distributed PV becomes an increasingly significant source of power generation and, at some point, its further growth might be limited by the challenges of its integration into the power grid.

To prevent these integration challenges from limiting the growth of solar PV installations and to maximize the overall system benefit, it is necessary to consider solar PV in all areas of power system planning, and to evolve the planning practices to better accommodate increased energy supply from solar PV.

This report reviews the entire power system planning process, including generation, transmission, and distribution. It discusses how the planning practices are changing to accommodate variable renewable generation, with a focus on future changes required to accommodate high penetration levels of solar PV and how to maximize the positive impact of other technologies such as load control and energy storage. The report also proposes several areas for future research that will help evolve planning methodologies and enable easier and more-effective integration of solar PV.

Electricity produced by solar PV currently is not cost-competitive with electricity generated by central stations, consequently solar PV has limited penetration in grid-connected applications. As the technology develops and solar PV becomes more competitive, it is expected that it will start supplying residential and commercial loads at the customer's side of the meter. This area of the power system has the highest cost of electricity, therefore it is where cost-competitiveness will be achieved first.

It is due to this assumption that solar PV commonly is regarded as a form of distributed generation and is being developed in accord with codes and standards that govern distributed generation, such as IEEE 1547¹, and UL 1741.² These are modern standards (in active development) and as such they provide ample support and guidance for current and near-term applications of distributed solar PV. The standards, however, are being developed on the important implicit assumption of low total penetration of distributed generation. Essentially, the envisioned purpose of distributed generation is to offset the consumption of its adjacent load, and it is not expected to ship much power back to the system. In contrast, this work is centered on the assumption of high penetration of distributed solar PV, and on analyzing what impact such a development will have on the power system.

¹ IEEE 1547 Standard for Interconnecting Distributed Resources with Electric Power Systems, 2003.

² UL 1741 Standard for Inverters, Converters, and Controllers for Use in Independent Power Systems.

Understandably, a sharp increase in the use of any one source of generation is likely to present integration challenges, but this especially is the case with the distributed solar PV for the following reasons.

- Solar PV is a variable source of generation—its power output depends on insolation and it is subject to potentially abrupt changes due to cloud coverage.
- Solar PV will evolve as a distributed source of generation first used to offset the connected load. As the penetration levels increase even further, two options are possible. Energy storage could be used to ensure that no power is returned to the system, and the power could be sent to other loads in the system to avoid capital investment for dedicated storage. The second option necessitates shipping power “backwards” through a part of the electricity delivery network—the distribution system—and backwards power flow is not a design feature of present-day distribution systems.
- The codes and standards that guide the integration of solar PV are focused on simplifying installations and prescribe grid interconnection requirements that cause minimal interaction with the grid. When solar PV becomes a significant overall source of generation in the power system, some of the present interconnection requirements likely will be counterproductive.

These challenges will be best addressed by concerted efforts of power utilities and solar PV technology developers, and will greatly benefit from carefully designed incentives and policies. Furthermore, continued collaboration of industry, utilities, and government in developing and evolving relevant codes and standards is seen as a key factor in ensuring graceful developments in this field.

In the field of power systems, *planning* is the activity with the most strategic impact, and it is a key to enabling adoption of any new technology. It therefore is of utmost importance to ensure that planning practices are ready to consider the new technology, and that such consideration is as convenient as possible.

2.0 Traditional Practices in Power System Planning

Traditional electric power systems are designed on the premise of power production in central generating stations and its delivery to the points of end use via transmission and distribution systems.

The role of generating stations is clear—they produce electric power or, more precisely, convert energy from another source into electric energy. The roles of transmission and distribution systems are more interrelated; both are concerned with power delivery, so additional clarification might be helpful. The role of transmission systems is to interconnect many generators and loads across entire regions and over state and country boundaries. Transmission systems enable the transfer of power over long distances, and thus facilitate economic and system benefits. They are designed and operated to optimize the use of the generation portfolio. They make it possible to supply loads from the most economical sources of power and to operate generating stations flexibly, allowing for optimization of their maintenance schedules and improved overall system reliability. Conversely, distribution systems are the part of electric delivery infrastructure that brings the power to the loads; they “touch” the load. The interface point between the transmission and a distribution system is a (distribution) substation. A distribution system usually includes the substation and all other infrastructure between the substation and the load, including primary circuits (feeders and laterals), service transformers, secondary circuits, and customers’ meters. Generally, distribution systems are designed for unidirectional power flow from the substation to end-use loads, and it is implicitly assumed that there is a sufficient supply of power from the transmission system (at the high-voltage side of the substation).

Traditional system planning activities follow this functional division, and commonly are segregated into generation planning, transmission planning, and distribution planning. Traditional planning practices are discussed in more detail in the following sections.

2.1 Generation Planning

The electric power industry is one of the oldest and well-developed industries in the United States. Consequently, all power generation planning is performed in the context of modifications to the existing system. The process begins with electricity load demand forecasting, which is followed by reliability evaluation to determine if and when additional generation is needed. Finally, optimal capacity expansions are selected based on economic considerations. These processes are reviewed briefly in the following sections.

2.1.1 Load Forecasting

Total system load generally is well known and a wealth of historic data is available. In the short term, load can be forecast with great accuracy, and this is performed daily to determine generation units’ commitment. Load forecasting for the purpose of generation planning, however, requires a substantially longer time horizon, because system expansion projects require long lead times, often between 2 and 10 years.

The outputs from a load forecast are a forecast of annual energy sales (in kilowatt-hours), and the annual peak demand (in kilowatts). There are two widely used methods in energy sales forecasting: econometric regression analysis, and end-use electricity models.

The usefulness of each method depends on data availability, customer segmentation, and the degree of detail required. Generally, the accuracy of predictions depends on the accuracy of assumptions, and the predictions can't be made with absolute certainty. For more details on econometric regression analysis, interested readers are referred to Pindyck and Rubinfeld (2000). End-use electricity models are physical, engineering-based methods that often are used in forecasting the residential load, and sometimes for commercial and industrial loads. Additional information and literature sources can be found in Stoll (1989).

Forecasting the peak demand is done based on forecasted energy sales by multiplying forecasted energy with an empirically determined load factor coefficient. Peak load is extremely sensitive to weather, and both the historic data and the forecast must be adjusted consistently to normalize them relative to the weather. After this baseline prediction is made it is adjusted based on the sensitivity to weather and the peak load is then predicted with the desired degree of confidence (Stoll 1989). To illustrate the consideration of weather effects, suppose that a baseline prediction is made that a system will have a future peak load demand of 10 gigawatts (GW) for an expected daily high (temperature) of 77°F. Let us further suppose that the daily high conforms to a normal distribution with a standard deviation of 3°F, and that the historically observed correlation between temperature and peak load is 300 megawatts (MW)/°F. It can then be concluded with 95% confidence that the peak load will be below 11.8 GW; 95% confidence corresponds to two standard deviations away from the mean, and this further corresponds to 6°F and 1800 MW of additional load. Note that this example is intentionally oversimplified; several other factors influence peak load, including wet bulb temperature (to account for humidity), wind speed, solar intensity, weather conditions over the past two days (thermal buildup effect), time of day, and time of year.

Peak load forecasting is important because it directly influences the required generation capacity—on every day of the year there must be enough available generation to feed the peak load. This is discussed below.

2.1.2 Relationship Between Capacity Reserves and Reliability

Generating stations require regular maintenance, which means that during some periods of the year they are not available to serve the load. The stations also can be out of service due to unforeseen equipment failures; these outages, called forced outages, also contribute to reduced availability. Assuming that maintenance requirements are known, and that forced outages can be characterized by probability, a natural question arising is, what is the appropriate capacity of generation for a given load forecast. Appropriate in this context is directly tied to reliability of service, and it then follows that we need to find a mapping between capacity and service reliability or, more precisely, between capacity margins and service reliability. Capacity margin is a better measure of reliability because it represents the difference between capacity and peak load (capacity alone is meaningless).

Required capacity reserves commonly are determined using a probabilistic approach that examines the probabilities of simultaneous outages of generating units and compares the resulting remaining capacity with the peak system load. A number of days per year with capacity shortages thus can be determined and this measure, termed loss-of-load-probability (LOLP) index, provides a consistent and sensitive measure of generation system reliability (Stoll 1989).

To determine LOLP index, both scheduled and forced outages are evaluated. Scheduled outages are representative of the downtime required for regular maintenance, and these outages are scheduled deterministically to avoid periods of high peak load. The forced outages are determined probabilistically, and the LOLP index is computed based on a large number of probabilistic experiments. Using a probabilistic method is advantageous in implementation as it allows for convenient inclusion of other factors, such as transmission limitations between interconnected systems, and for simulation of a large number of units. LOLP calculations commonly are performed for an entire interconnected system, as this properly evaluates the benefits of shared generation reserves. A common target value for the LOLP index is 1 day per 10 years, which is equivalent to 0.1 day per year.

Therefore, given a system and the outage characteristics of the units, planners can determine whether it satisfies the desired LOLP index. The converse however is not true; it is not possible to go from a desired LOLP to the optimal system expansion. Planning the expansion to meet the desired LOLP (i.e., reliability), and do so at a minimal cost is discussed next.

2.1.3 Capacity Resource Planning

The question of what type of generating station (hydroelectric, nuclear, coal, gas turbine, or other) would be the most economical addition to the system is answered by combining a production cost analysis with an investment cost analysis.

The process is illustrated in Figure 1. The evaluation begins by preparing a set of expansion scenarios. An expansion scenario includes additions of multiple units and the planners are required to hypothesize the type and the number of units that should be considered. Hypothesizing on the type of units can be aided by using *technology-screening curves*—more details on this can be found in Stoll (1989). The planners also make assumptions on unit additions over time (e.g., a 200-MW gas turbine by 2011, a 400-MW coal-fired plant by 2015); and they also consider unit retirements. Deciding which scenarios to evaluate is a subjective process, and it depends on the planners' preferences and experience.

The scenarios then are evaluated one at a time, beginning with a multiyear reliability simulation to determine the LOLP index for each year of study. If the reliability requirements are not met they often can be improved either by advancing the installation dates of some units, or by delaying retirement dates of others. The corrected scenario then is reevaluated and possibly refined again until the reliability targets are met. Note that these iterations eventually might fail to give acceptable reliability; this possibility should not be regarded as a deficiency of the process, but rather as an indication of an inadequate

scenario. If found, then inadequate scenarios are removed, and the process continues to consider the scenarios that meet the reliability target.

The next step in evaluating scenarios is to run a multiyear production simulation for each. Production simulation determines the dispatch of every unit and its associated running costs—such as costs of fuel and maintenance. Cumulative fuel costs of a unit depend on the unit’s dispatch—how often it runs and at what operating point. Production simulation determines the dispatch and associated costs for all units in the system, and these costs are recorded for each year of the multiyear study. This is shown symbolically as the data output to the right of the “multiyear production simulation” processing block. Multiple data outputs are shown (stacked)—each corresponds to one expansion scenario.

Of course, each expansion scenario also has associated construction costs. This is shown as an “investment costing of additions” block—it outputs yearly expenditures for each scenario.

The cost data from production simulation and from investment costing are expressed on a basis of present value to account for time value of money. The total costs then can be computed, and the least-cost scenario can be selected by simple inspection.

Note that this process is centered on cost, and as such it is best suited for use by vertically integrated utilities. When deregulation of electric power industry occurred, generation companies became independent of other utility businesses and generation capacity development became a result of market forces. In the deregulated environments, separate markets exist for energy and capacity. It is the capacity market that responds to the system-reliability requirements, but this discussion is outside of scope of this study. Integration of high penetration solar PV into generation planning is discussed later. Traditional transmission planning methodologies are discussed below.

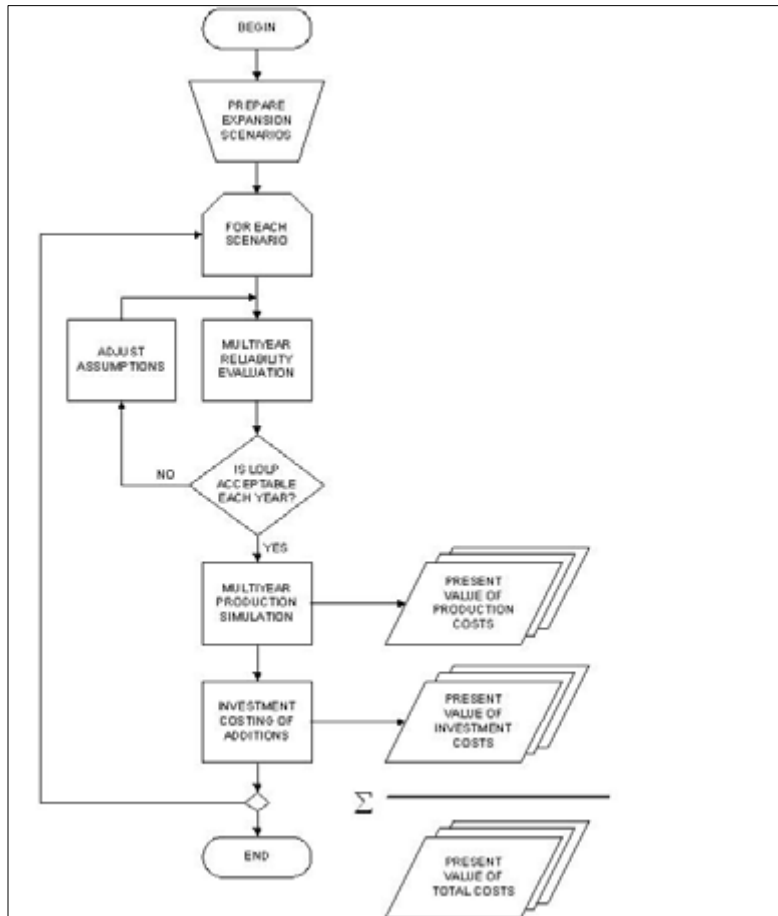

Figure 1. Least-cost generation planning (adopted from Stoll 1989)

2.2 Transmission Planning

As noted, the chief role of a transmission system is to optimize the use of a generation portfolio; a transmission system makes it possible to supply loads from the most economical sources of power, and operate generating stations flexibly and thus improve overall system reliability.

Transmission planning therefore ensures that the transmission infrastructure can deliver power from the generators to the loads, and that all the equipment will remain within its operating limits in both normal operation and during system contingencies.

Contingencies in this context mean unexpected failures of any system element; for example a generator or a transmission line could have an unexpected outage, which would force the remainder of the system to transition to a new operating point. Studying these transitions and ensuring that a stable operating point can be reached after any contingency is an essential part of transmission system planning.

Transmission system planning is closely interrelated with generation planning. To understand this, it is helpful to note that power flows through a transmission system are a direct result of generation dispatch; a transmission system itself has very limited ability to control the line flows. Therefore, to study the power flow through a transmission system, it is necessary to know the corresponding generation dispatch; to determine the (optimal)

generation dispatch, however, the parameters and flow limitations imposed by the transmission system must be known. This “loop” is not always easy to resolve, and it might require complicated iterations between the two planning processes.

Generation dispatch and the associated power flows change many times throughout the day and often follow rather different seasonal schedules. The transmission system therefore can exist in many diverse operating states, and in each one it must be able to cope with the loss of any single element. Transmission planning is tasked with evaluation of all these operating states and their associated contingencies and determining the stability of the system for the set of worst-case conditions. Selecting a set of worst-case conditions is not straightforward and it is most often based on historical system performance and planners’ experience and judgment.

Fundamentally, evaluating power system stability is equivalent to evaluating its dynamic performance following system events. This commonly is done using specialized computer programs that include a variety of component models—generators, excitation systems, governor-turbine systems, loads, and other components are all represented, and their dynamic performance (time domain response to disturbances) is simulated and evaluated. It is a common practice to explicitly model the dynamic behavior of generators, excitations systems, governor-turbine systems, and loads by differential equations, and to represent the network elements—transmission lines and transformers—by algebraic equations (Grigsby 2007).

Stability typically is evaluated in three categories: rotor angle stability, voltage stability, and frequency stability (Grigsby 2007), discussed below.

2.2.1 Rotor-Angle Stability

Rotor-angle stability is the ability of generators in the interconnected power system to remain synchronous after a system disturbance. As discussed in the introduction above, generating stations convert energy from some other source of energy into electric energy. Traditionally the interface between the two is a generator and, under steady-state conditions, the electrical torque balances the mechanical torque that is driving the generator, so that the generator operates at a constant speed. This balance can be disturbed at any time, leading to excursion of rotor angles and corresponding electromechanical oscillation. Based on the type of disturbance, rotor-angle stability consideration can be further classified into small signal (or steady-state) stability, and large disturbance (or transient) stability.

2.2.1.1 Small Signal Stability

Small signal stability refers to disturbances sufficiently small to warrant analysis by linearization of system equations around the operating point. Consequently, they can be analyzed in the context of linear systems theory. Small signal stability is evaluated relative to the following physical phenomena:

- Local modes—oscillations of a small group of machines (often in the same power station) relative to the power system

- Inter-area modes—oscillations of a group of machines in one part of the system against another group of machines in another part of the system
- Control modes—oscillations brought on by control interactions between system elements
- Torsional modes—commonly associated with the interaction between a turbine-generator shaft system and another system element, usually a line compensated by a series capacitor.

2.1.1.2 Transient Stability

Transient stability deals with large disturbances and evaluates the ability of a system to maintain synchronism when subjected to a severe disturbance. The resulting system response involves large excursions of generator rotor angles and the governing equations are nonlinear. The analysis typically is done by time domain simulations that include models of generator prime mover dynamics, excitation dynamics, and load dynamics.

2.2.2 Voltage Stability

The essential cause of voltage instability is the voltage drop that occurs on the inductive reactances associated with the transmission network. In a heavily loaded system, voltage to the load reduces due to these voltage drops, and this increases current draw from the load, so the positive feedback leading to instability can be established easily. The situation becomes progressively worse as some of the generators reach the reactive power capability limit (essentially the current limit), and the end result is voltage collapse at the load. These events can be precipitated both by loss of generation and loss of transmission, and typically are evaluated by time domain simulations that include voltage-sensitive models of load, and the responses of generator excitation systems.

2.2.3 Frequency Stability

Frequency stability studies determine the system's ability to maintain steady frequency within a nominal range following a severe system disturbance that results in a significant imbalance between generation and load. A system's response to frequency stability includes block load shedding and other special protection schemes that typically are not considered in simulations that deal with rotor stability and voltage stability.

In theory, if the generation capacity is correctly planned, then the system should not be exposed to transients associated with frequency stability. Unforeseen circumstances can arise in operations, however, and planners try to be prepared to deal with them. Furthermore, generation capacity is planned with a very long time horizon and construction delays or other events can cause unplanned capacity shortages.

2.3 Distribution System Planning

Distribution systems are the part of electricity delivery infrastructure that serves the load. Traditionally distribution systems are optimized for the lowest cost that meets the desired reliability of service, and reliability is carefully tracked and reported. This has profound implications on planning practices, because reliability is explicitly engineered into the system, and is used as an important metric in evaluating planning options.

2.3.1 Load Forecasting

Load forecasting is critically important in distribution system planning and, arguably, distribution utilities are in the best position to make accurate load forecasts. Distribution utilities directly meter their customers and therefore have access to the exact data needed. They also are notified of development projects in their service territory early in the process and, through that mechanism, have a good insight into prospective load growth. Other than that, load forecasting generally follows the procedures discussed in section 0 above. Given their proximity to the load, distribution utilities have the necessary data to successfully employ end-use electricity models.

2.3.2 Planning for Reliability

Reliability in distribution planning is defined and evaluated quite differently compared with reliability evaluation in generation planning. Typical reliability indices used in distribution planning are listed in Table 1. Evaluation of reliability is not absolute (as is the case in generation planning via computing of an LOLP index) but incremental. Reinforcement and planning options are considered relative to their impact on reliability. One example of such a process, termed Cost-Effective Reliability Improvement (CERI) is described in Willis (2004). It begins with known baseline reliability, and then evaluates many possible improvement options relative to their impact on customer reliability. Options are ranked based on their cost-benefit ratio, and the best ones are implemented.

Table 1. Typically Reported Distribution Reliability Indices (IEEE 1366³)

Name	Acronym
System Average Interruption Frequency Index	SAIFI
System Average Interruption Duration Index	SAIDI
Customer Average Interruption Duration Index	CAIDI

2.3.3 Distribution System Engineering

Of course, there is much more to distribution system design than load forecasting and planning for reliability. Important design choices include distribution substation siting and sizing and feeder layout (including choosing a number and placement of reclosers and sectionalizers). Additionally, studies that address feeder voltage control, feeder protection, and motor starting also are required. These activities are often classified as distribution system engineering and are discussed below, in the context of their interaction with high penetrations of distributed PV.

³ IEEE Standard 1366, Guide for Electric Power Distribution Reliability Indices, 2003.

3.0 Project Approach

The review presented in this report is based on recent developments in electric power industry that were triggered by the adoption of Renewable Portfolio Standards and by the related move within the industry towards integration of renewable sources of generation, primarily towards transmission-connected wind generation.

The knowledge gained in integrating wind generation can and should be leveraged for integrating solar PV, and this report capitalizes on the similarities between the two. At the same time, solar PV also is saliently different from transmission-connected wind because it is installed as a distributed resource and has no inherent inertia. The impact of these specific features is evaluated based on their envisioned effect on system planning practices; this process is inevitably subjective but it is expected that the most important aspects are covered in this report.

4.0 Impact of High-Penetration Solar PV on Power System Planning

To set the context of the discussion that follows, it is helpful to define *high penetration*. There are two fundamental ways to define penetration, either by a metric of energy or by a metric of peak power.

Defining penetration by energy quantifies energy supplied to the system from renewable sources of interest, and such a definition relates directly to displaced fossil generation and the associated savings in fuel consumption and lowered emissions. The energy-based definition is very useful in consideration of large systems and is used in many Renewable Portfolio Standards. The inherent complication of using this definition is that it implicitly depends on the quality of a resource. To achieve equal penetration, more equipment is needed in regions with lower insolation, so the same level of penetration can result in different underlying circuit behavior when evaluated in different regions, depending purely on the quality of the resource.

A power-based definition provides for a more consistent relationship between penetration and circuits' problems—it is defined as nameplate capacity of intermittent generation (installed in a circuit or system) divided by the peak load (of that circuit or system). This report deals primarily with circuits' problems, therefore a power-based definition of penetration is preferred.

This report considers high penetration to be levels up to 50%, but the absolute percentage is of limited value unless it is considered with respect to some other aspect of the system. In general, it is more appropriate to examine the sensitivity of studied phenomena to the level of penetration rather than the penetration level itself.

4.1 Impact of Variable Renewable Energy Generation

The variability of renewable energy sources is a key challenge associated with their integration into the power system. Generation planners think in terms of peak load and generation capacity—at any time, they must have enough available capacity to serve the peak load. To illustrate the notion of availability, compare a 200-MW thermal power plant with a 200-MW wind farm. Assuming a 6% outage rate, a thermal power plant generally can provide its full 200 MW during 94% of considered hours, whereas a 200-MW wind farm might be anywhere between zero and 200 MW depending on the available wind.

The uncertainty associated with renewable generation variability adds complexity to the planning process, and generally results in more demanding operation of the balance of generation portfolio. Non-renewable generators now have to maneuver more in order to accommodate the variability of renewable sources. This increases the operating costs per unit of energy from thermal generation but it also results in lower overall thermal generation and, thus, lower cumulative fuel usage, lower cumulative fuel costs, and lower emissions. These beneficial effects are the exact reasons for the industry's move towards using renewable energy, but this is of little value to the owners of thermal plants whose operating costs per unit of produced energy become higher. These incremental costs are

termed “integration costs,” and their fair allocation has been—and still is—a subject generating strong interest in the industry.

4.2 Implications for Generation Planning

One way to effectively include intermittent renewable generation in the capacity-planning process is to plan for system energy, not for peak load. This is discussed below.

4.2.1 Capacity

Process flows of traditional and emerging capacity-planning practices are compared in Figure 2.

The traditional planning process is not designed to consider variable generation, therefore the initial response of the industry was to simply exclude it from capacity planning. The overall process is recapped here to illustrate the specifics of dealing with renewable generation. The process starts with the forecasting of the load energy growth, and this is immediately followed by the associated forecast of the peak load. The generation and transmission capacity then are planned to match the forecasted peak load. Renewable generation is taken in “as available” during system operation, and the output from committed thermal units is reduced to enable the intake of energy supplied by the renewable sources. The end result is sub-optimal system operation; on average, thermal units run below their rated power point, resulting in lower efficiency, higher emissions, and greater operating costs.

The emerging practice is to include renewable energy supply early in the planning process and consider it during energy growth forecast. This allows for full integration of renewable generation into the planning process; the key is in viewing variable renewable generation as a part of the load. The planning process is thus based on the net load—the system load is reduced to account for contribution from renewable generation. The amount of applicable load reduction is estimated based on historical renewable resource data that is scaled to predict renewable generation from existing and planned new installations. The resulting net load has increased variability compared with the original system’s load, and at high penetration this variability must be explicitly characterized to ensure that the balance of generation portfolio has enough flexibility to cope with increased variability. Generation and transmission then are planned relative to net load, and with sufficient flexibility to meet the net load requirements. This evaluation of flexibility is a fundamentally important step, as it has a direct impact on the system’s operating costs. Namely, a dispatch order might have to be changed to accommodate net load variability, which will result in different operating costs as compared with supplying the equivalent amount of “pure load.” For example, it might happen that a lowest-cost power plant does not have sufficient flexibility to match the variability of a net load. The original plant would be replaced in the dispatch by a more expensive but flexible plant.

Another way to manage “flexibility shortage” is to curtail production from variable renewable sources and thus reduce the net load variability to a manageable level. This is acceptable if the flexibility shortage occurs infrequently enough to not warrant a change in dispatch order, but if curtailments become extensive it will make renewable resources unattractive and also impede their development. Future options might include providing

flexibility by introducing direct load control or by using energy storage to cancel out the variability of renewable sources.

One attractive option is to reconsider the siting of renewable generation. An initial plan might concentrate all of the planned additions to the region with the best renewable resource. This makes sense, but if it ultimately leads to transmission congestion then it could prove cost effective to avoid transmission upgrades and simply develop part of the renewable resources at an alternative site.

The evaluation process should be iterative, denoted by the “modify” return step in the flow chart. Evaluating various options in the context of generation planning enables meaningful comparison of the costs versus the benefits they provide.

Implications of high-penetration solar PV on the balance of generation portfolio are discussed by reviewing its impact on net load and on required generation flexibility. This is the examined the sections below.

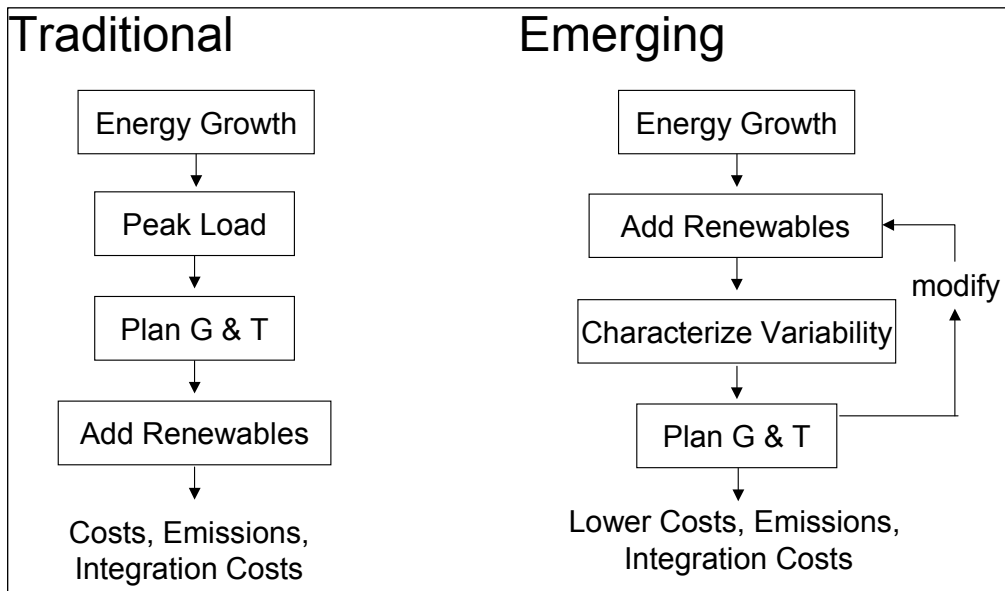

Figure 2. Traditional and emerging practice in capacity planning

4.2.2 Characterizing the Net Load

System load is variable; it varies with the time of day, the day of the week, and with different seasons. Renewable generation also varies; it follows the variations of a renewable resource which, in turn, follows its own daily and seasonal patterns. An illustrative example of these variations is depicted in Figure 3, where the hourly loads of California ISO for July 2007 are compared with solar generation based on actual resource data scaled to represent system-wide 30% penetration of PV. The resulting net load also is shown. Dots on the chart represent actual data points, and the thick lines are the computed averages.

The significant shift in net load relative to a system load pattern can be observed. It is apparent that ~30% penetration of solar PV shifts the timing of minimum net load to around 11 a.m., and that for many samples this minimum reaches below the minimum original load. This can cause significant shifts in generation scheduling, and it has to be further evaluated for its impact on daily commitment and dispatch, and the associated generation costs. A detailed study requires production simulation, but a rudimentary insight can be obtained by studying load duration curves.

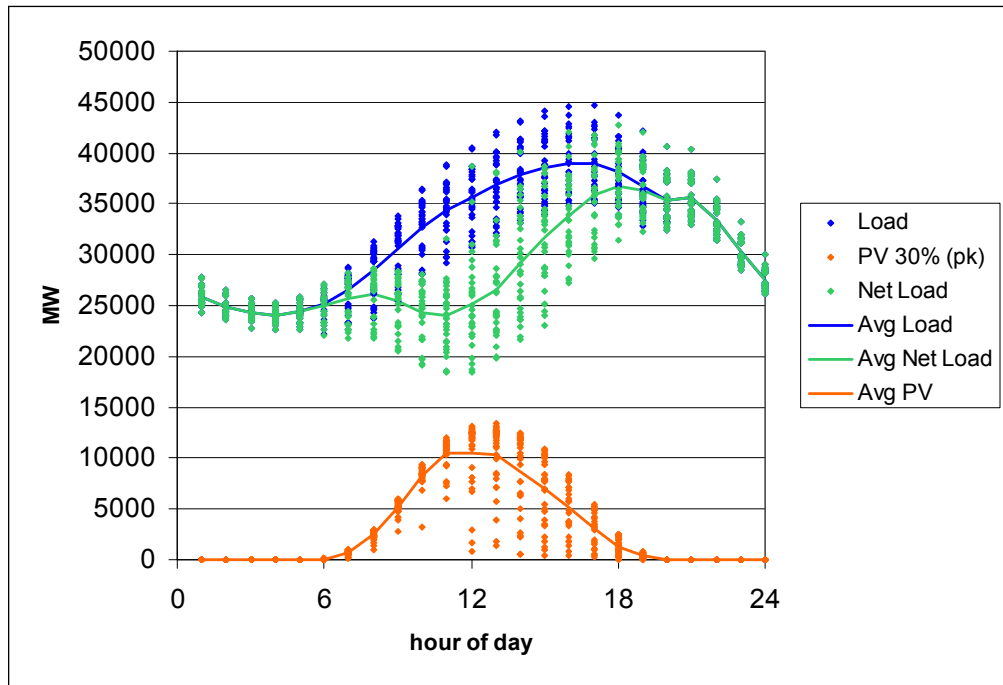

Figure 3. System load, PV generation, and net load (CAISO July 2007)

Load duration curves are created by sorting load samples from highest to lowest; the resulting plot provides a powerful insight into the relationship between peak and light load, and into the overall shape of the load profile. Load duration curves for an original system load and net loads with increasing solar PV are shown in Figure 4.⁴

⁴ Load duration curves normally are plotted for an entire year. Because this is a high-level discussion, this report uses a simpler setup and the analysis is limited to one month of data.

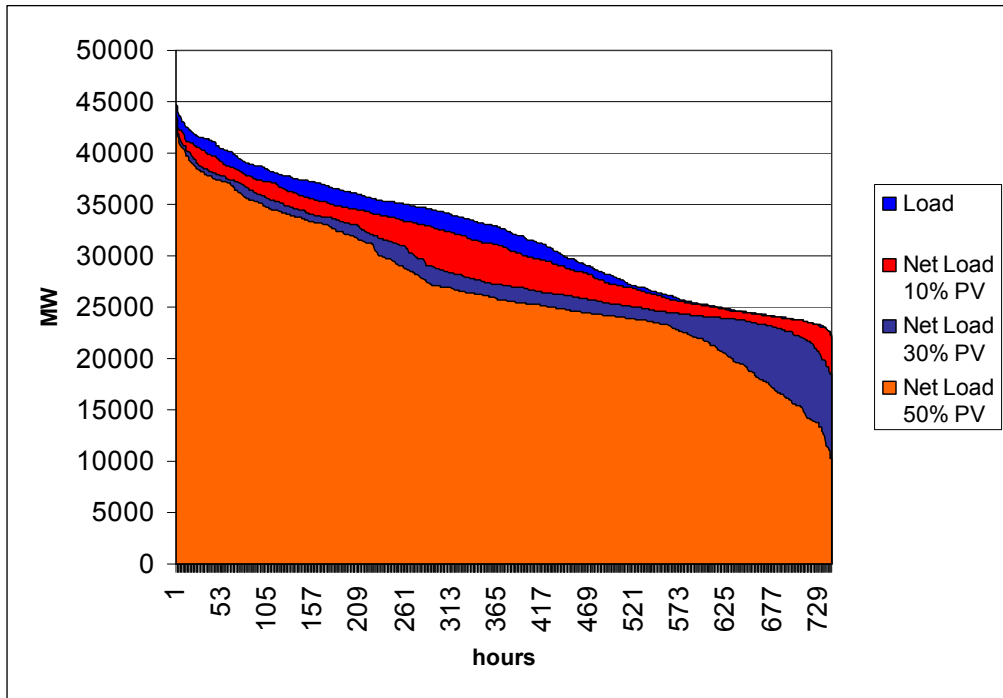

Figure 4. Load duration curves, load and net load with 10%, 30%, and 50% PV penetration (CAISO July 2007)

Several important observations can be made. Peak load is reduced by the addition of solar PV; this generally lowers the system operating costs because the expensive peaking units do not run as often as before. Additionally, a penetration level of up to 10% reduces system load during high demand and makes no appreciable impact on the minimum load. This means that penetration of solar PV of up to 10% would have an insignificant impact on scheduling of other generation, and consequently would have low integration costs. Penetration levels greater than 30% cause a reduction in the minimum system load, and in an extreme case of 50% penetration, cause a significant reduction during approximately 100 operating hours over a period of one month (13.4% of the total number of hours). As shown in Figure 3, this minimum load occurs around 11 a.m., and can cause significant integration challenges.

The process of integrating renewable sources is explained as iterative via the “modify” step in the flow chart. One effective and simple way to lessen the integration challenges brought by 50% solar PV is to change the orientation of some of the panels. Instead of all of the panels facing south and producing their maximum output at about 11 a.m., a proportion of panels can be oriented more towards the west, which would shift their maximum power production to a later time. Note that offering higher electricity rates in mid afternoon would result in a change of orientation of all panels, which would just shift the problem from 11 a.m. to another time. Optimally, a spread of orientations would be achieved, and some creativity in structuring rates to drive such behavior will be necessary. This is a simple illustration of the need for active participation of the utilities and system operators in managing high penetration of solar PV.

4.2.3 Characterizing the Impact on Fuel Mix

Net load curves also can be used to gain rudimentary insight into which type of generation is displaced by the intermittent renewable generation. Each system has an associated generation portfolio, and this portfolio is dispatched daily to serve the load. Generated electrical energy then can be linked back to the type of fuel used to produce it, and this establishes the understanding of the fuel mix of the system. The daily dispatch is done to minimize the total cost. Each type of generation has an associated cost, and load duration curves also can be used to predict the dispatch order and the costs of electricity associated with different levels of load. This is illustrated in Figure 5, where the net load duration curve corresponding to 30% solar PV is “filled” by a generation fuel mix representative of California. Starting from the bottom of the graphic, the load is shown to be served by nuclear, then hydro,⁵ followed by renewable (wind),⁶ then coal and petroleum, and finally natural gas. It is clear from this figure that solar PV displaces only gas-fired generation so the wholesale market price for electricity generated by solar PV in this example would be equivalent to the price of gas-fired generation.

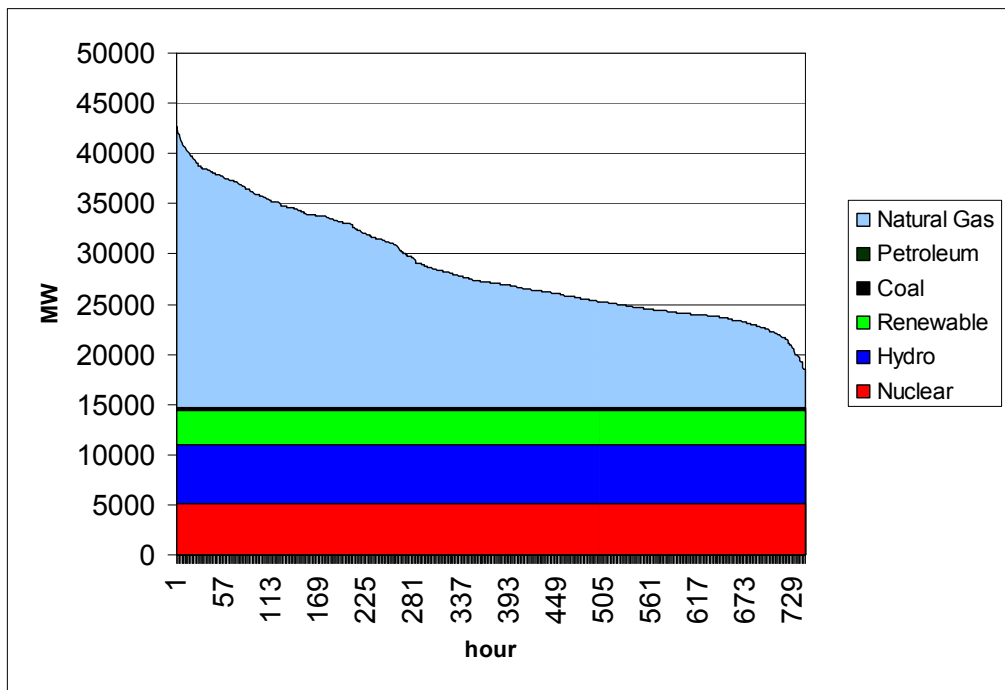

Figure 5. Dispatch order for 30% PV penetration, assuming California fuel mix (CAISO July 2007)

For comparison, Figure 6 shows a dispatch order for the same net load but assuming the U.S. fuel mix. Again, most of the displaced generation is gas-fired, but there also is some from coal-fired plants. This could be an indication of possible integration challenges, because coal plants typically are cycled only once per day. They are taken off-line during the night and brought back on at some point during the morning load rise. The minimum

⁵ The stacking order of hydro is somewhat arbitrary and it can be used effectively to manage variability or minimum demand.

⁶ Strictly speaking, wind generation should be incorporated into net load, but to simplify the discussion this was avoided.

load caused by solar PV occurs around 11 a.m., this means that coal-fired plants would have to be kept off-line longer than before, and that the morning load rise would need to be served by more flexible gas-fired plants. Such dispatch order would result in increased system operating costs, but it would also reduce the number of running hours for coal plants, possibly forcing some of the less efficient ones into retirement. This is an example of a situation where running a full production simulation is required in order to accurately predict actual dispatch order.

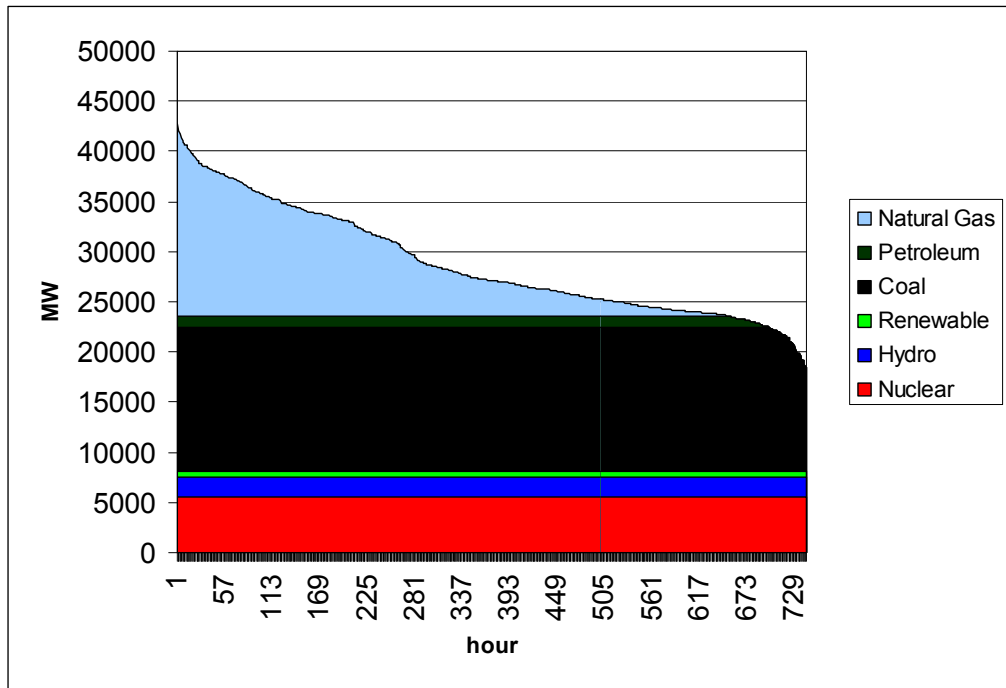

Figure 6. Dispatch order for 30% PV penetration, assuming U.S. fuel mix (CAISO July 2007)

The requirements for increased flexibility of the balance of generation portfolio are discussed below.

4.2.4 Generation Flexibility

The need for generation flexibility comes from the need to control the system frequency, so it is helpful to briefly review frequency control in the power system. Present-day power systems rely on rotating generators for most of their energy and, accordingly, the system frequency is directly proportional to the rotating speed of the generators. Furthermore, the rotating speed of the generators depends on the balance of generation and load. If the load is greater than available generation the system slows down, and if the generation is greater than the load, the system accelerates. The load changes continuously, so the generation must be adjusted continuously to control the frequency to its rated value. How these adjustments occur is discussed below.

Consider the sketch shown in Figure 7; a frequency control area⁷ is represented by a closed curve and it includes the total generation “G” and the total load “L.” The area also can exchange power with adjacent areas—two importing interfaces are shown on the top, and an exporting one at the bottom left. The speed of the area’s “equivalent generator” is determined by the differential equation:

$$J\omega \frac{d\omega}{dt} = P_{gen} - P_{load} + P_{imports} - P_{exports}$$

where J stands for the equivalent moment of inertia of all generators, ω is the equivalent angular velocity (proportional to frequency), and the power terms have expected meanings.

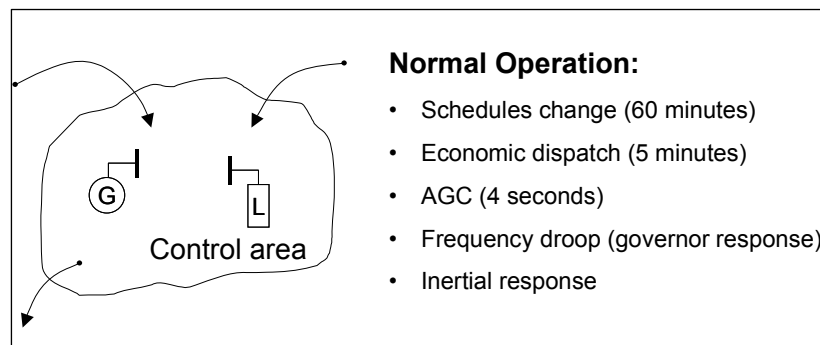

Figure 7. Control area and layers of frequency control (values typical)

In normal operation, the control area follows a predetermined schedule of power exchange with its neighboring areas. Schedules are prepared based on the forecasted load and are negotiated well in advance; they are an input to system operation in real time. Schedules between areas typically change on the hour and therefore the generation is re-dispatched every hour. Then, because the load is continuously varying, units are re-dispatched in economic order every five minutes—the new set points are communicated from the control center to all generators. The residual generation/load imbalance is handled by the automatic generation control (AGC) and also is done centrally. Every four seconds the updated set points are communicated to the subset of units (those participating in AGC). The remaining two actions—the frequency droop and inertial response are done locally at each generator—generators are configured to lower their output if the system frequency rises and to increase it if the frequency drops. This has a stabilizing effect on the power system and ultimately limits the frequency drop/rise following system disturbances (such as an unplanned outage of a generating unit or loss of a large load). Finally, inertial response of generators is the response with fastest dynamics—if the system frequency drops, then a generator connected to the system must slow down, and to do so it must deliver the energy from its rotating mass to the system.

⁷ Power systems are operated as aggregates of smaller entities called control areas. This helps manage the system more effectively and facilitates trade of power between the areas. Area boundaries are largely administrative, but they are carefully monitored to facilitate billing for exchanged power.

Planning for generation flexibility deals with the first two aspects of frequency control: economic re-dispatch of units every five minutes (called load following), and automatic generation control (called regulation). Both aspects should be evaluated relative to the net load. Understanding the load-following and regulation capabilities of the system is important in determining the system's response to load changes and in evaluating its ability to maintain the frequency within the desired control range (NERC's CPS2 defines a performance standard for frequency control).

4.2.4.1 Load Following

Load-following requirements for the system can be determined based on statistical analysis of net load data. Net load variability must be carefully evaluated at various levels of system load and then compared to the flexibility of committed balance of generation portfolio. Correlation between intermittent renewable resource and system load plays an important role in this; generally solar resource is better correlated to the load than wind. This has two important consequences.

- Solar generation is easier to integrate into the system than wind generation because of its lesser impact on incremental variability of net load compared to variability of load alone.
- Solar generation has higher value to the system than wind because of its availability during higher load demand—compared to wind, solar PV displaces more expensive generation.

As the penetration of renewable generation increases, net load variability could eventually become higher than the available load-following flexibility of the balance of generation portfolio. It is important to understand that this will not be an abrupt change; the shortage of load-following capabilities first will appear during a few hours over the course of the year, and the total time in which shortages are noticeable gradually increases as the penetration levels increase. Forcing the burden of variability management on other generation might then become uneconomical, and other options to manage net load variability should be considered. There are a variety of options that can be used to reduce net load variability at the time scale of load following. Spatial diversity of the resource, flexible conventional generation, grid operations and control areas, limited curtailment for extreme events, load management, and, at high penetrations, energy storage, all can be used to reduce net load variability at the time scale of load following. Evaluating these mitigation options (based on their cost-benefit ratio relative to the flexibility they provide to the system) is an important area of future study. Design of efficient markets dedicated to load following is another example of needed future work.

4.2.4.2 Regulation

As in the case of load-following requirements, regulation requirements are determined based on statistical analysis of net load data, but at the finer time scale (recall that load following relates to five-minute updates, while regulation relates to four-second updates). After the regulation requirements are determined, establishing appropriate regulation capabilities is done based on past operating experience—the appropriate regulation for known variability is extrapolated to determine the required regulation for expected variability.

Present deregulated power systems in the United States operate markets for regulation service and it is reasonable to expect that these markets will correctly respond to increased needs for regulation associated with increased penetration of intermittent renewable generation. As with load following, regulation services need not be provided only by the balance of generation portfolio, other technology options are available as well. Emergence of new technologies and their participation in regulation service markets will be an interesting future development.

4.3. Implications for Transmission Planning

Integration of renewable generation does not require strategic changes to the process of transmission planning. Renewable generation must be modeled accurately, however, and this accuracy becomes critically important as the penetration levels increase.

When building the models, it is not reasonable to represent each PV source individually; they have to be organized into aggregates and connected through aggregate equivalent impedances. Equivalent impedances should represent the parameters of the distribution feeder and at least two levels of voltage transformation that exist between transmission-level voltage and distributed PV.

Furthermore, distributed PV generation is connected to the system through the inverters, and modeling the performance characteristics of the inverters in the time scale of interest for transmission system dynamics requires consideration. The general characteristics of PV inverters are reviewed and the relevant modeling requirements are discussed below.

4.3.1 Common Characteristics of PV Inverters

PV inverters typically consist of two distinct stages, the PV module interface, called the boost converter, and the grid interface, called the grid converter.⁸ An illustrative PV inverter topology identifying the boost and grid converters is shown in Figure 8.

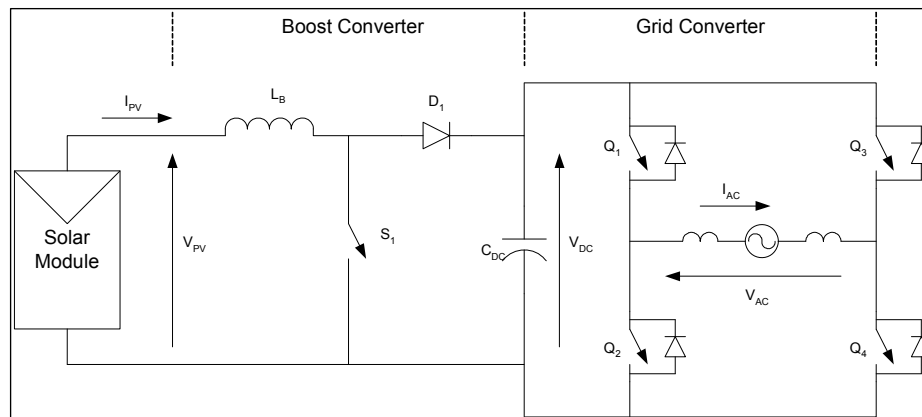

Figure 8. An illustrative PV inverter topology

⁸ Single-stage topologies exist but they rely on high voltage (>1000 VDC) from a solar module. The NEC limits the voltage of solar modules to less than 600 VDC, therefore boost stage commonly is employed in the United States.

The DC capacitor C_{DC} shown at the boundary of two converters is shared by the converters and it provides energy storage that functions as the buffer for energy transfer between the two converters.

The role of the boost converter is to continuously extract energy from the solar module and to transfer it into C_{DC} . The boost converter modulates the switch S_1 , it continuously adjusts its duty cycle to control V_{PV} relative to V_{DC} . Adjusting V_{PV} determines the current from the solar module (labeled I_{PV}). Solar modules have nonlinear voltage current characteristics and adjusting V_{PV} is important to achieve maximum power extraction. Example voltage-current and voltage-power characteristics are shown in Figure 9. By selecting V_{PV} to correspond to point A in Figure 9, power extraction from the PV panel is maximized. The role of the boost converter is to track this operating point for changing insolation.

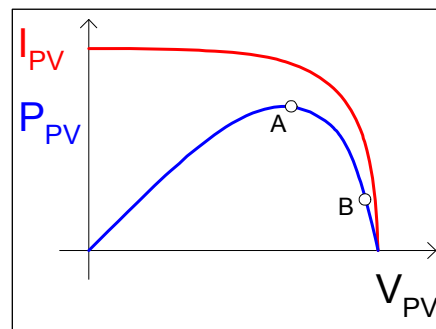

Figure 9. An example voltage current and voltage power characteristic of solar module

At the same time, the grid converter takes the energy from C_{DC} and supplies it to the grid, represented here as an AC source of voltage labeled V_{AC} . The voltage across C_{DC} (V_{DC}) always must be greater than or equal to the peak of V_{AC} to enable operation without significant AC current distortion (AC current is labeled I_{AC} in Figure 8). The grid converter controls the magnitude of I_{AC} to supply desired amount of power to V_{AC} . In a steady state, power supplied to the grid matches the power extraction from the solar module, and the voltage V_{DC} across C_{DC} is maintained at the constant value.

The grid converter also can control the phase angle of I_{AC} relative to V_{AC} to exchange reactive power with the grid. Exchanging reactive power does not require energy, and it is limited only by the current capacity of the switches Q_1 through Q_4 .

4.3.2 PV Inverters' Behavior During Grid Faults

Currently, PV inverters are required to disconnect from the grid during grid faults. Experience gained from wind industry suggests that staying connected during the fault and helping to restore the voltage after the fault is cleared⁹ aids system stability. It therefore is reasonable to expect that the PV industry will face similar requirements as the penetration levels increase.

⁹ This feature is known as low-voltage ride through (LVRT) or zero-voltage ride through (ZVRT).

Suppose, for example, that the grid experiences the fault and that due to this fault V_{AC} falls to some low value (it is “shorted” by the fault). During the fault, the grid inverter no longer can supply power to V_{AC} (power is the product of voltage and current, and if the voltage is brought to zero due to a fault, the power delivered to the AC circuit also becomes zero). This makes it impossible to remove energy from C_{DC} , and if the boost converter continues to transfer energy from the solar module to C_{DC} , V_{DC} will start to rise. The rise of V_{DC} is a signal to the boost converter that something is wrong and so it moves the operating point from point A to point B as shown in Figure 9. (Point B is shown at a power higher than zero to indicate that some active power is used internal to the inverter, and that some can be fed to the grid even during faults; generally, fault current travels through the conductors to reach the short circuit and this has associated power losses.) Operating point B can be assumed in a matter of milliseconds and it then is maintained for the duration of the fault. After the fault is cleared (many are cleared within 100 ms), the boost inverter has to transition back to point A; generally no information is provided by the manufacturers on the speed of this reverse transition.

4.3.3 Modeling PV Inverters for Transmission Planning

As discussed above, transmission planning is based on studying system recovery after various contingencies. Commonly a fault is applied to the system model and the response of the system then is studied during the fault and immediately after it is released.

As the penetration level of PV sources rises during the coming decades, these sources will displace traditional generation more and more, and become significant participants in system dynamics. To enable proper evaluation of these dynamics, PV inverters must be represented with the amount of details analogous to the representation of conventional generators. Models of conventional generators commonly include representation of generators’ and turbines’ inertia, detailed excitation models, models of governor controls, and models of power system stabilizers (where applicable). In contrast, PV inverters are in most cases represented simply by a fixed negative load, and no dynamic behavior is modeled.

This practice will have to change as the penetration of distributed PV increases. Dynamics of maximum power point tracking will have to be represented explicitly to enable study of the behavior of PV inverters due to changes in insolation, or during fault recovery. Similarly, the dynamics of anti-islanding detection must be modeled to enable quantifying the interaction between PV inverters and grid frequency control. Lastly, the ability of PV inverters to deliver VAR support through the distribution system to the bulk grid will have to be evaluated based on the future practices in distribution system design. This novel modeling style is used in representing PV inverters in the associated RSI report entitled *Transmission System Performance Analysis for High-Penetration PV*.

4.4 Implications for Distribution Planning and Engineering

Distributed PV generation affects distribution system planning and engineering in three essential ways.

- It affects feeder voltage regulation.
- It makes contributions to fault currents.
- It can provide an ungrounded source of voltage.

Each of these effects is discussed in the following subsections.

4.4.1 Feeder Voltage Regulation

If the penetration level of the PV inverters is sufficiently high, reverse power flow through the distribution system might start to occur during some periods of the day. This can create unanticipated conditions and cause misoperation of the utility voltage control equipment.

Generally, reverse power flow through the feeder causes a voltage gradient from the distributed PV towards the substation, and this voltage rise might push the feeder and service voltage beyond the limits suggested by ANSI C84.1.

In many situations, this voltage rise can be brought to within limits by adjusting the on-load tap-changer (OLTC) in the substation, but the control of OLTC somehow must be made aware of PV generation. A properly configured line compensation can be sufficient in most cases, but more-sophisticated control schemes based on communications of remote voltage points also are possible.

Voltage control on an example distribution feeder and options for reactive power delivery from distributed PV to the grid are analyzed and presented in the associated RSI report entitled *Distribution System Performance Analysis for High-Penetration PV*.

4.4.2 Contributions to Fault Currents and Protection Desensitization

Most modern PV inverters employ self-commutated inverters that operate in current control mode. This results in the exceptionally fast short-circuit protection and limiting of fault currents to less than 2-pu peak value that is removed within 1 ms. Compared with fault currents supplied by conventional generators, inverter fault currents are negligible and unlikely to cause significant damage.

Inverter-coupled PV sources have a more significant impact on protective relaying; transformer-connected PV inverters can provide a ground path and affect the magnitude of zero-sequence currents. This could cause protection desensitization and must be carefully evaluated on a case-by-case basis.

4.4.3 Ungrounded Source of Voltage

PV inverters can be coupled to the distribution system via transformers, and based on the transformer connection they can provide an ungrounded source of voltage to the distribution system island that is formed after the substation breaker is opened. This can cause high line-to-ground voltages on the unfaulted phases during single line-to-ground fault.

These problems can be avoided by selecting an appropriate transformer connection. Generally, good grounding arrangements also create sources for ground current that could interfere with circuit protection. A more detailed discussion and a comprehensive list of references are provided in Short (2004).

4.4.4 Software Tools Used in Distribution Engineering

Another RSI report, entitled *Utility Models, Analysis and Simulation Tools*, discusses existing software tools and outlines the strategy for future software development that will improve handling of distributed generation in the distribution engineering software. Specific recommendations are provided with regard to load flow analysis, short-circuit studies, and protection coordination.

5.0 Conclusions and Recommendations

This report explores the impact of high-penetration renewable generation on the system planning methodologies, and outlines how these methodologies are evolving to enable effective integration of renewable generation sources. All three areas of system planning—generation, transmission, and distribution—are considered, and the impact of high penetration of solar PV is analyzed relative to each. The key concepts are summarized below.

5.1 Generation Planning

Generation planning is concerned with providing sufficient generation capacity to serve the load with the desired reliability, and with ensuring that the resulting generation portfolio has sufficient flexibility to cope with the variability of the load.

5.1.1 Capacity

- The emerging practice in capacity planning is to plan for the system's energy demand, not its peak load. This allows for full integration of renewable generation into the planning process. The key is in viewing intermittent renewable generation as a part of the load. The planning process is based on the net load, the system load is reduced to account for contribution from renewable generation. The amount of applicable load reduction is estimated based on historical renewable resource data scaled to predict renewable generation from existing and planned new installations. The generation capacity planning then can be handled using standard tools. Reliability calculations (such as LOLP) should consider thermal plants only.

5.1.2 Flexibility

- The flexibility of the generation portfolio is characterized by its load-following and regulation capabilities, and both should be evaluated relative to net load. Load following refers to economic re-dispatch of the entire generation portfolio every five minutes, and regulation refers to system frequency control by automatic generation control. Setpoint updates are sent every four seconds to the units participating in AGC.
- Explicit evaluation of load-following requirements in the presence of intermittent renewable generation is a new dimension in generation planning. The emerging practice is to determine load-following requirements based on a statistical analysis of net load data. Net load variability must be evaluated carefully at various levels of system load and then compared with the flexibility of the committed balance of generation portfolio. Future research should focus on defining required flexibility from the standpoint of net load, and on matching that with available flexibility from the balance of generation portfolio. Developing a methodology to accurately quantify the available flexibility also is required.
- As the penetration of renewable generation increases, net load variability eventually could become higher than the available load-following flexibility of the balance of generation portfolio. Forcing the burden of variability management on other generation then might become uneconomical, and other options to

manage net load variability should be considered. Options such as load control, load shifting, use of energy storage, and curtailment of renewable generation sources all can be used to reduce net load variability at the time scale of load following. Evaluating these mitigation options (based on their cost-to-benefit ratio relative to the flexibility they provide to the system) will be an important area of future study.

- Design of efficient markets dedicated to load following is another example of needed future work.
- As in the case of load-following requirements, regulation requirements are determined based on statistical analysis of net load data, but at the finer time scale (load following relates to five-minute updates and regulation relates to four-second updates). After the regulation requirements are determined, appropriate regulation capabilities are established based on past operating experience. Appropriate regulation for known variability is extrapolated to determine required regulation for expected variability. Present deregulated power systems in the United States operate markets for regulation service and it is reasonable to expect that these markets will respond correctly to increased needs for regulation associated with increased penetration of intermittent renewable generation. As with load following, regulation services need not be provided only by the balance of generation portfolio; other technology options are available. Emergence of new technologies and their participation in regulation service markets also will be interesting future developments.
- Accurate day-ahead renewable resource forecasting enables more-accurate unit commitment, which results in significant operating cost reductions. Improvements in renewable resource forecasting, both long term (multi-day) and short term (hours and minutes ahead), will lead to substantial benefits in system operation. Resource forecasting is an important area of future work. At the same time, resource data collection and extraction of relevant statistics are important for evaluation of future load-following and regulation requirements.

5.2 Transmission Planning

Transmission planning ensures that the transmission infrastructure can deliver power from the generators to the loads, and that all the equipment will remain within its operating limits both in normal operation and during system contingencies.

Evaluation of contingencies consists of studying a system's dynamic behavior that is precipitated by the contingencies. The dynamic model of the system is carefully maintained (in load-flow software), and time domain simulations are performed for many contingencies and then evaluated to determine which are critical. Transmission expansion and reinforcement plans are evaluated relative to their impact on critical contingencies.

- Integration of renewable generation does not require strategic changes to this process, but renewable generation has to be accurately modeled, and this accuracy becomes critically important as the penetration levels increase. Performance characteristics of inverters have to be evaluated for their impact on transmission system dynamics. The impact of the inverter's maximum power point tracking on

system dynamics, and the impact of anti-islanding schemes on transmission system frequency control should be considered.

5.3 Distribution System Planning

Distribution system planning is concerned with the infrastructure that serves the load. Distribution systems are very diverse and operate under a variety of weather conditions that affect loads. They serve different types of loads with widely varying spatial topologies, and use different voltage levels and diverse system equipment. It therefore is challenging to draw generalized conclusions about distribution systems, but several observations were made that are uniformly applicable relative to high solar PV penetration levels.

- Distribution systems currently are designed under the assumption of power flow from a substation to end-use loads. Depending on the penetration level, solar PV can cause a reversal of power flow through the distribution system, and this is the likely source of problems. Correlated load and insolation data are needed to predict the maximum amount of reverse power flow for a feeder under consideration.
- Distribution systems rely on a coincidence factor of loads for sizing all of the equipment. Installed loads are not likely to operate simultaneously, and the designers take advantage of this. Equipment is sized for the expected coincident load rather than the maximum load. The probability of coincident operation of solar PV is much higher, because an entire distribution service area can easily be subject to the same insolation. This places the upper boundary on solar PV penetration; the installed peak capacity must be lower than the coincident load.
- Problems caused by high penetration of distributed solar PV can be reliably predicted by careful analysis (simulation), but it should be noted that the software tools used in distribution planning require assiduous harmonization with respect to modeling PV inverters. To enable this, a set of guidelines for modeling solar PV inverters should be created and perhaps included in the standards. This will eliminate a lot of confusion and unwarranted concerns that inevitably result from inconsistent and possibly inaccurate modeling.
- Solutions for most problems caused by high penetration of solar PV can be found in existing technology. It is reasonable, however, to expect that installing substantial distributed generation of any type will require modifications to the existing distribution systems, and that these modifications require some capital investment. To minimize this investment and build up the confidence of the industry, it will be helpful to provide plenty of examples of best practices and to showcase simple and effective solutions.
- Currently, solar PV installations are handled like installations of grid-connected distributed generation, using processes that often are slow and ineffective. As the penetration levels increase, the industry will shift towards handling PV installations like installations of appliances; the utilities will not need to be notified. On one hand, this is desirable because it reduces installation costs. On the other hand, the practice is not sustainable if the solar PVs are destined to

become a significant source of energy for the power system. To avoid unexpected problems, utilities will have to include characteristics of solar PV in all areas of system planning. One way to address this is to create a set of automated tools for screening prospective solar PV installations. Any prospective installation then would be conveniently reported, screened by the system, and either approved or floated up to the utility for a more detailed evaluation. Once approved, it would get be recorded and included in all relevant databases and further used in all areas of system planning. Such screening also will enable utilities to track and report integration costs, and later recover them either through tariffs or by other means.

5.4 General Recommendations

- As the penetration levels rise, distributed PV installations might be required to provide performance characteristics similar to those of traditional generators. Such requirements could include inertial response, frequency droop characteristics, reactive power injection, and the ability to curtail production. Current inverter technology is able to support these grid-friendly features, albeit at the small penalty of inverter efficiency and slightly higher capital cost. However, many inverters currently sold are highly optimized for efficiency and have no ability to provide grid-friendly features. To change this, a careful evolution of standards, policies, and incentives is required.
- Furthermore, enabling inverters to provide grid support only completes part of the job. The other necessary part is the communication link from the system operator to every installed inverter. This communication link can take many forms; a simple broadcast on FM radio might be sufficient to accomplish the required minimal functionality, but high-bandwidth, full-duplex communication (if deployed) could be leveraged in many different ways and it would create opportunities for more-effective distribution system management, more-flexible system configurations, faster restoration, more-selective protection, efficient deployment of demand response, efficient implementation of real-time metering, introduction of creative electricity tariffs, and more. Pilot programs, sharing the existing high-speed Internet infrastructure, could help evaluate the possible benefits and guide design decisions for the dedicated infrastructure.

6.0 References

Grigsby, L.L., ed. (2007). *Power System Stability and Control*. Boca Raton, FL: CRC Press.

Pindyck, R.S.; Rubinfeld, D.L. (2000). *Econometric Models and Economic Forecasts*. New York: McGraw-Hill.

Short, T.A. (2004). *Electric Power Distribution Handbook*. Boca Raton, FL: CRC Press.

Stoll, H.G. (1989). *Least-Cost Electric Utility Planning*. New York: Wiley-Interscience.

Willis, H.L. (2004). *Power Distribution Planning Reference Book*. 2nd edition. New York: Marcel Dekker.

REPORT DOCUMENTATION PAGE

Form Approved
OMB No. 0704-0188

The public reporting burden for this collection of information is estimated to average 1 hour per response, including the time for reviewing instructions, searching existing data sources, gathering and maintaining the data needed, and completing and reviewing the collection of information. Send comments regarding this burden estimate or any other aspect of this collection of information, including suggestions for reducing the burden, to Department of Defense, Executive Services and Communications Directorate (0704-0188). Respondents should be aware that notwithstanding any other provision of law, no person shall be subject to any penalty for failing to comply with a collection of information if it does not display a currently valid OMB control number.

PLEASE DO NOT RETURN YOUR FORM TO THE ABOVE ORGANIZATION.

1. REPORT DATE (DD-MM-YYYY) February 2008			2. REPORT TYPE Subcontract Report			3. DATES COVERED (From - To)		
4. TITLE AND SUBTITLE Power System Planning: Emerging Practices Suitable for Evaluating the Impact of High-Penetration Photovoltaics					5a. CONTRACT NUMBER DE-AC36-99-GO10337			
					5b. GRANT NUMBER			
					5c. PROGRAM ELEMENT NUMBER			
6. AUTHOR(S) J. Bebic					5d. PROJECT NUMBER NREL/SR-581-42297			
					5e. TASK NUMBER PVB7.6401			
					5f. WORK UNIT NUMBER			
7. PERFORMING ORGANIZATION NAME(S) AND ADDRESS(ES) GE Global Research 1 Research Circle Niskayuna, NY 12309					8. PERFORMING ORGANIZATION REPORT NUMBER ADC-7-77032-01			
9. SPONSORING/MONITORING AGENCY NAME(S) AND ADDRESS(ES) National Renewable Energy Laboratory 1617 Cole Blvd. Golden, CO 80401-3393					10. SPONSOR/MONITOR'S ACRONYM(S) NREL			
					11. SPONSORING/MONITORING AGENCY REPORT NUMBER NREL/SR-581-42297			
12. DISTRIBUTION AVAILABILITY STATEMENT National Technical Information Service U.S. Department of Commerce 5285 Port Royal Road Springfield, VA 22161								
13. SUPPLEMENTARY NOTES NREL Technical Monitor: Ben Kroposki								
14. ABSTRACT (Maximum 200 Words) This report explores the impact of high-penetration renewable generation on electric power system planning methodologies and outlines how these methodologies are evolving to enable effective integration of variable-output renewable generation sources.								
15. SUBJECT TERMS power system planning, capacity planning, distributed generation, solar PV, photovoltaics; GE Global Research; National Renewable Energy Laboratory; NREL								
16. SECURITY CLASSIFICATION OF:			17. LIMITATION OF ABSTRACT UL	18. NUMBER OF PAGES	19a. NAME OF RESPONSIBLE PERSON			
a. REPORT Unclassified	b. ABSTRACT Unclassified	c. THIS PAGE Unclassified			19b. TELEPHONE NUMBER (Include area code)			

Standard Form 298 (Rev. 8/98)
Prescribed by ANSI Std. Z39.18