Technology Commercialization Showcase 2008 Vehicle Technologies Program

PATRICK DAVIS, ACTING PROGRAM MANAGER



<http://www.eere.energy.gov>

Email: patrick.davis@ee.doe.gov

Tel: 202-586-8061

Agenda



- Industry Landscape
- Program Objectives
- Technology Commercialization Opportunities
- Unexploited Investment Gaps

Agenda



- Industry Landscape
- Program Objectives
- Technology Commercialization Opportunities
- Unexploited Investment Gaps

Commercial and passenger vehicles are responsible for a significant portion of our petroleum consumption and CO2 emissions



Transportation Sector Petroleum Consumption

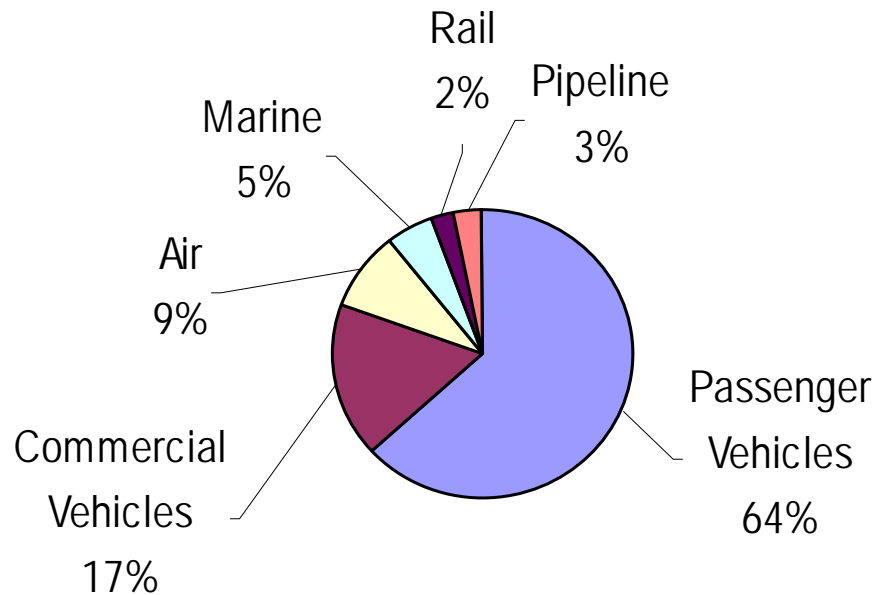

Carbon Dioxide Emissions by End Use Sector

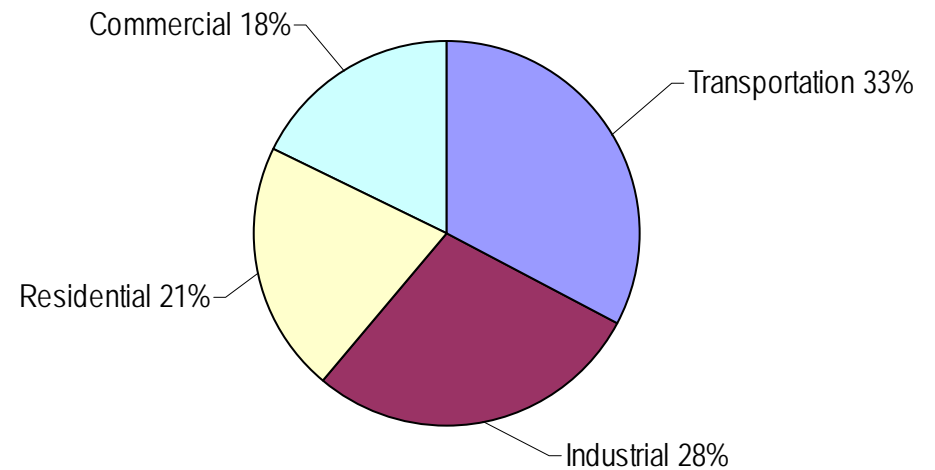

The transportation sector accounts for 2/3 of the oil use in the U.S. and is the fastest growing petroleum consuming sector.

The transportation sector accounts for 1/3 of the carbon dioxide released in the U.S. and is the fastest growing source.

Rapidly changing industry landscape is creating new market opportunities



- **OEMs**
 - Squeezed by change in consumer behavior
 - Changes in energy policy
 - Higher fuel prices
- **Suppliers**
 - Lack of suppliers for advanced vehicle technologies
 - Squeezed by rapidly changing product
 - Low-margin business
- **Infrastructure**
 - Fuel distribution (E-85)
- **Utilities**
 - Smart Metering
 - Vehicle 2 Home/Vehicle 2 Grid (V2G)

A gap between domestic petroleum production and consumption necessitates changes to our nation's vehicle fleet

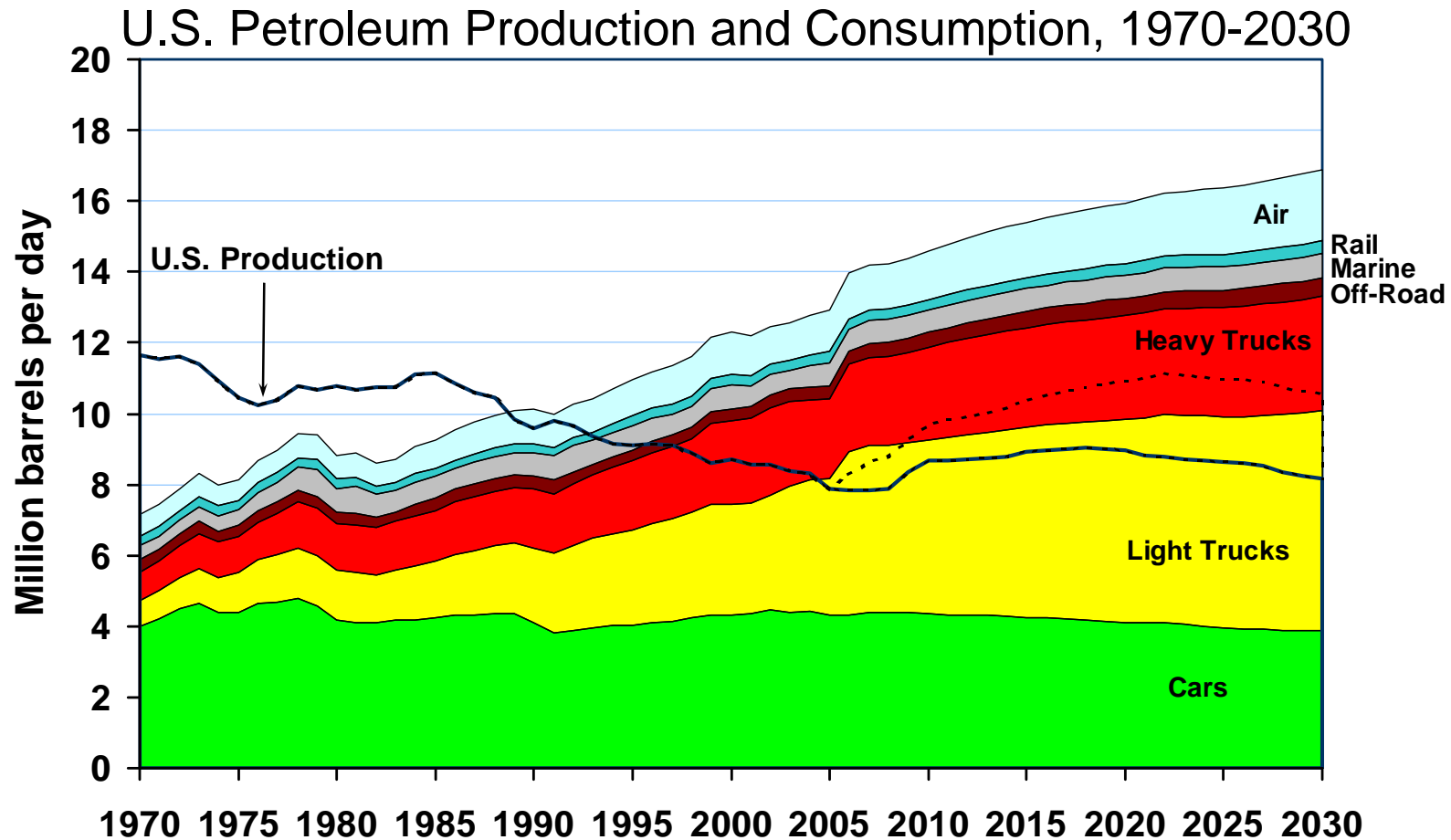

Sources: *Transportation Energy Data Book: Edition 26* and projections from the *Annual Energy Outlook 2008*.

Notes:

- The U.S. Production has two lines after 2005. The solid line is conventional sources of petroleum. The dashed line adds in other inputs -- ethanol and liquids from coal. Historical petroleum production includes crude oil, natural gas plant liquids, refinery gains, and other inputs, which include liquids from gas, liquids from coal, and alcohols, ethers, petroleum product stock withdrawals, domestic sources of blending components, other hydrocarbons, and natural gas converted to liquid fuel.
- The sharp increase in values between 2005 and 2006 are the result of the data change from historical to projected values.

High gasoline prices and increased sales of alternative fueled vehicles are poised to change the nation's automotive landscape

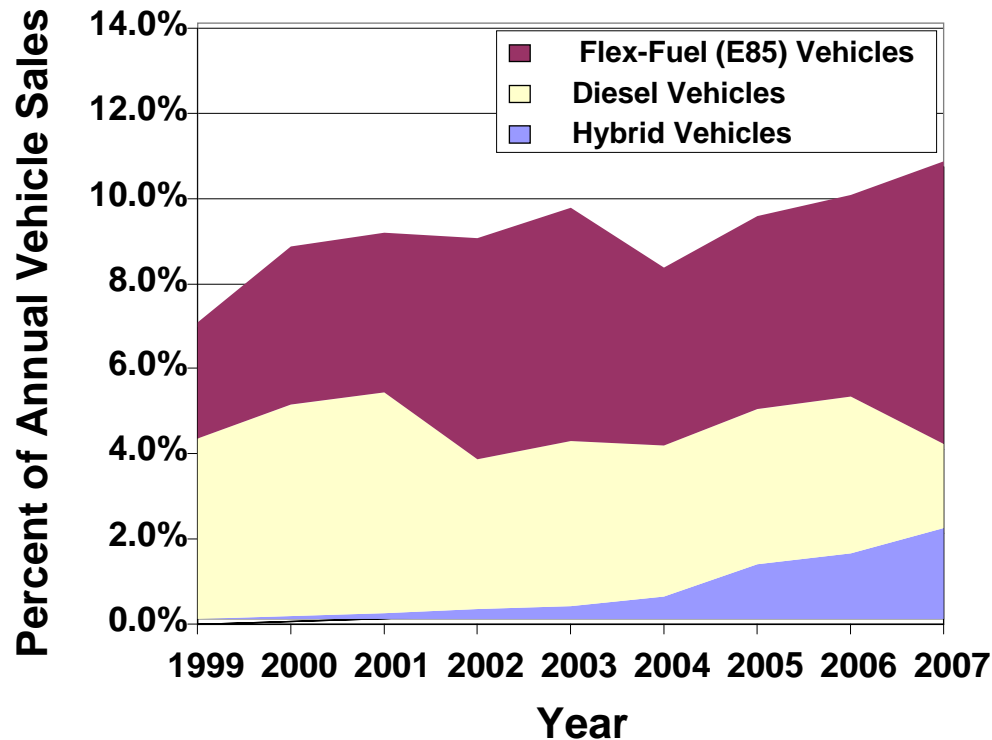

PHEVs are Not Part of the Current Vehicle Mix

U.S. Market

- About 230 million vehicles on the road
- 17 million new cars & light trucks per year
- Hybrid vehicles now approaching three percent of sales
- 13 million cars and light trucks taken out of use per year
- Average cradle-to-grave vehicle life is long (16.9 years for a car & 15.5 years for a light truck)
- Total estimated retail value of current year hybrid market is \$12 billion (average \$25k/vehicle)

Agenda



- Industry Landscape
- **Program Objectives**
- Technology Commercialization Opportunities
- Unexploited Investment Gaps

Through R&D, DOE is accelerating the development of advanced vehicle technologies



Advanced Technologies for High Efficiency Clean Vehicles

Hybrid Electric Systems

- Advanced Batteries
- Power Electronics/ Inverters/Controllers & Motors
- Systems Analysis and Testing
- Aerodynamics, Rolling Resistance & Accessory Loads



Tech Introduction

- EPA Act/EISA
- Rulemaking
- Deployment
- Validation
- Student Competitions
- Graduate Automotive Technology Education

Advanced Combustion Engine R&D

- Low Temp. Combustion R&D
- Emission Controls
- Light- & Heavy-Duty Engines
- Waste Heat Recovery
- Health Impacts

Fuels Technology

- Bio-Based Fuels
- Clean/Efficient Combustion Fuel Characteristics
- Fischer-Tropsch Fuels & Blendstocks
- Advanced Lubricants

Materials Technology

- Lightweight Structures
- Composite Development
- Processing/Recycling/ Manufacturing
- Design Data Test Methods
- High Temperature Materials Laboratory

DOE invests more than \$196 million in R&D to improve efficiency and reduce petroleum consumption



2008 Appropriation in \$Millions

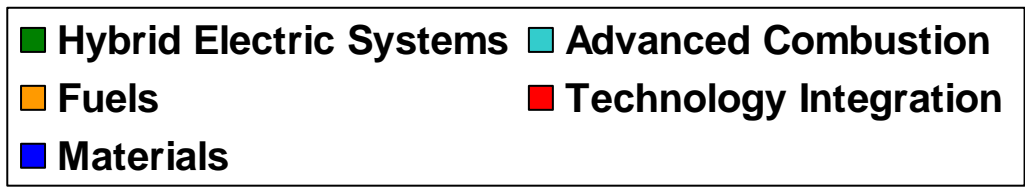
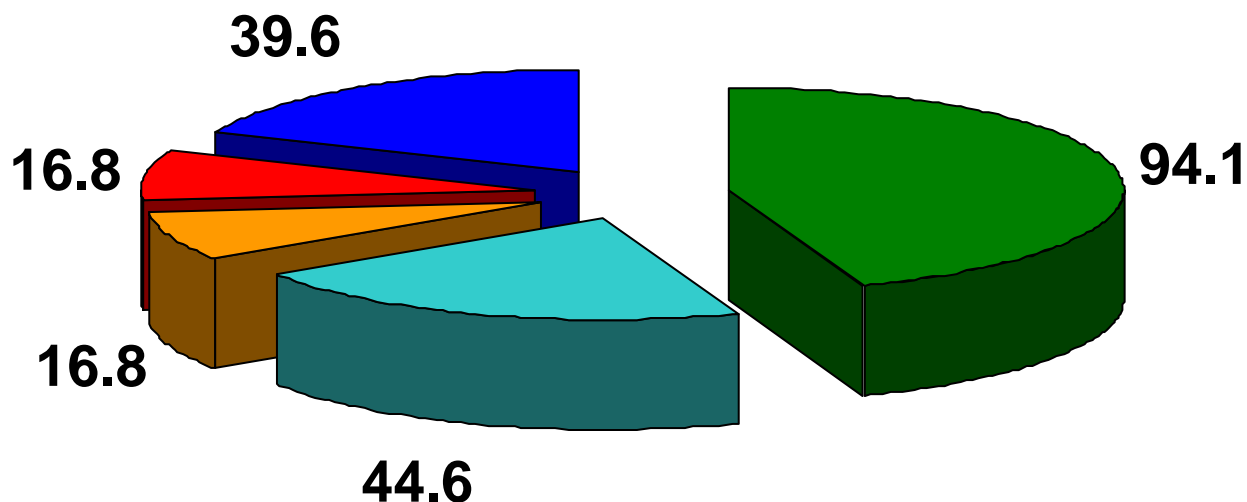

Major Technology Success Stories



Deployed Technologies	Technology Partners	Policy Implications	Market Impact
Nickel Metal Hydride Batteries	Cobasys	Royalty payments to Treasury	Every US Hybrid Vehicle sold has IP from this battery research
Quick Plastic Forming of Aluminum	GM PNNL ORNL	Higher Energy Efficiency	Chevrolet Malibu MAXX 2004, Cadillac and GM Vehicles
Light Duty Diesel Engine	Cummins ORNL SNL	Higher Energy Efficiency for Light Vehicles	Agreement with DaimlerChrysler for 2009 volume production

Agenda



- Industry Landscape
- Program Objectives
- **Technology Commercialization Opportunities**
- Unexploited Investment Gaps

Commercialization Opportunities: Smart Battery Status Monitor



• Description

Hardware device that can measure battery impedance near real-time.

• Impact

- Domestic transportation market
- U.S. Department of Defense
- U.S. Department of Navy

• Technology Readiness

• Estimated Time to Market

- 0.5 to 1 year (stand alone impedance device)
- 2 to 4 years (Smart Battery Status Monitor)

• Estimated Commercialization Cost

- \$1.5M – proof of principle

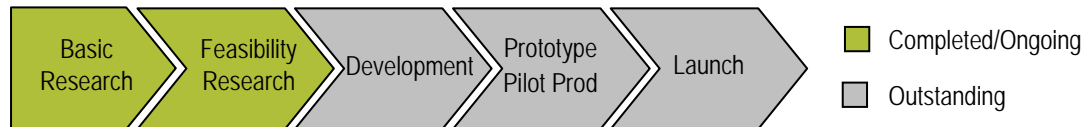

<u>Customer</u> Battery Manufacturers* Vehicle Producer*	<u>Partner</u> Laboratory	<u>Successful Demonstration</u> Laboratory
--	------------------------------	---

*Potential

Smart Battery Status Monitor



- **PROBLEM:** No good means presently exist to quickly and accurately predict the remaining life of a battery. Further, the required 15-year battery life and commensurate warranty issues for advanced batteries for hybrid and plug-in hybrid electric vehicles leads manufacturers to seek a rapid way of measuring important battery parameters such as capacity, resistance, power, state of charge, state of health, and remaining life.
- **DESCRIPTION OF INVENTION/TECHNOLOGY:** : Idaho National Laboratory (INL), Montana Tech, and Qualtech Systems Inc. (QSI), are partners in the development of a hardware device that can measure battery impedance near real-time. This device when coupled with INL's diagnostic and prognostic models and battery testing and analysis methodologies, Montana Tech's signal processing development, and QSI's TEAMS diagnostic modeling software will enable determination of the battery's state of health and remaining life in-situ and near real-time.
- **IP POSITION:** Two separate but related in-situ impedance measurement devices have been demonstrated in the INL Energy Storage Technology Laboratory:
 - Impedance Noise Identification (high resolution) - patent pending
 - Compensated Synchronous Detection (near real time, lower resolution) – patent awarded
 - Invention disclosures will soon be submitted for enhanced versions of both of these methods.
- **IMPACT:** The Smart Battery Status Monitor has utility for the domestic and international transportation vehicle market and to other users of advanced batteries e.g., the U.S. Department of Defense, NASA, etc.
- **TECHNOLOGY STATUS:** Two separate but related in-situ impedance measurement devices have been demonstrated in the INL Energy Storage Technology Laboratory, i.e., the patent pending Impedance Noise Identification System (high resolution) and the patented Compensated Synchronous Detection System (near real time, lower resolution).

Structurally Integrated Cathodes for Li-Ion Batteries



• Description

Layered metal oxide cathode materials are stabilized

• Impact

- Greatly enhanced inherent safety
- Significantly reduced heat from ARC tests

• Technology Readiness

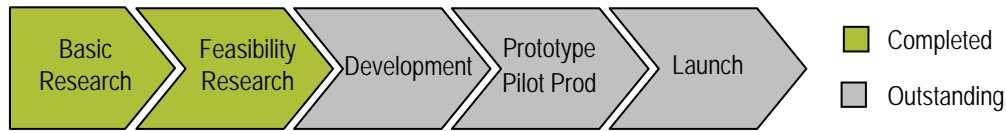

• Estimated Time to Market

- 1 to 5 years

• Estimated Commercialization Cost

- \$10-20 million

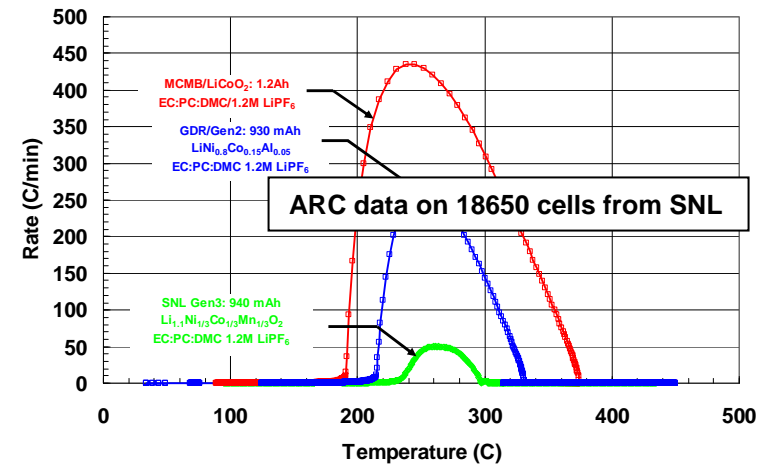

Reduced oxygen activity, associated with new cathode materials, significantly reduces potential for thermal runaway.

	<u>Customer</u>	<u>Partner</u>	<u>Successful Demonstration</u>
Potential	Cell Manufacturer	Laboratory Manufacturer*	Laboratory



Commercialization Opportunities:

Structurally Integrated Cathodes for Lithium-ion Batteries

- **PROBLEM:** More stable Li-Ion cell materials & chemistries are needed to facilitate their commercial acceptance for hybrid electric vehicle and electric vehicle applications.
- **DESCRIPTION OF INVENTION/TECHNOLOGY:** Layered metal oxide cathode materials are stabilized by structurally integrating electrochemically inactive material with electrochemically active material.
- **IMPACT:** These structurally integrated cathode materials are much more stable than conventional layered metal oxide cathode materials, leading to enhanced inherent safety and longer life.
- **IP POSITION:** Suite of inventions of this type available.
- **TECHNOLOGY STATUS:**
 - 7 issued patents, 3 published patent applications, and several additional invention reports
 - Initial patents have been licensed & materials proven in licensee's product
 - Licensing currently available for a wide variety of applications: consumer electronics, power tools, toys, vehicles, etc.
 - Direct substitution for conventional LiCoO_2 cathode, which means no new processing methods needed
 - Need precursor processing equipment and calcining (high-temperature) furnaces for producing these new cathode materials

Magnetic Processing for Next-Generation Materials



- **Description**

- Manipulates crystal structure and orientation to achieve microstructures

- **Impact**

- 20-50 percent lighter weight designs
- 80 percent extension in component life
- 80 percent lower residual stress



Magnetic Processing Facility

- **Technology Readiness**

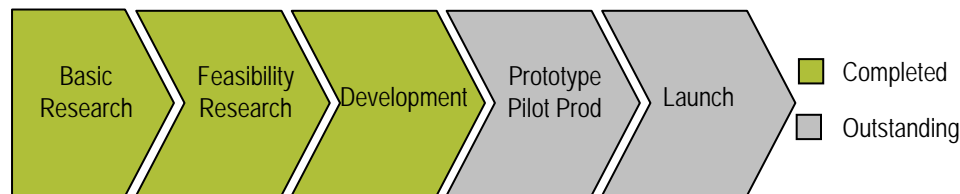

- **Estimated Time to Market**

- 2-3 years

- **Estimated Commercialization Cost**

- \$2 million

*Potential

<u>Customer</u> Automotive Metal Fabrication*	<u>Partner</u> Laboratory Automotive Supplier*	<u>Successful Demonstration</u> Laboratory
---	---	--

Magnetic Processing for Next-Generation Materials



- **PROBLEM:** Unique phase stability and microstructures in materials cannot be achieved with traditional processing techniques.
- **DESCRIPTION OF INVENTION/TECHNOLOGY:** This treatment technology exploits the use of high strength magnetic fields (order of 10-30 Tesla) to manipulate material phase orientation to develop unique microstructure-property combinations – especially, for polymorphic materials whose parent and product phases exhibit different magnetization behaviors.
- **IMPACT:** Developing the next generation of advanced structural and functional materials using high magnetic field processing will lead to 20-100 percent lighter weight designs, 80 percent reduction in residual stress, and 80 percent extension in component life. New nanomaterial structures are achievable with broad applications. Significant energy reduction in steel component manufacturing processes.
- **IP POSITION:** Two patents have been awarded, three pending patent applications filed.
- **TECHNOLOGY STATUS:** ORNL operates a bench-scale demonstration facility at Nine Tesla

Carbon Nanotubes and Graphene Sheets Have Been Grown in High Magnetic Fields

The figure consists of three transmission electron microscopy (TEM) images arranged horizontally. The first image on the left is labeled "Starting Material" and shows a dark, granular surface with several dark, circular spots. A scale bar in the bottom left corner indicates 0.4 μm. The middle image shows a bundle of single-walled carbon nanotubes, appearing as a series of parallel, slightly curved lines. A scale bar in the top left corner indicates 2 nm. The third image on the right shows a large, flat, hexagonal graphene sheet. A scale bar in the bottom left corner indicates 5 nm.

EDS analysis indicates that the bigger particles contain Cr & Co

Single-Walled Nanotubes Bundle

Graphene sheets can produce carbon nanotubes, e.g., armchair, zig-zag, and chiral



Commercialization Opportunities: Low-cost Carbon Fiber

Description

- Technologies under development address cost reduction opportunities in the area of feedstock development and processing

Impact

- Reduce vehicle mass up to 40 percent
- Reduce oil consumption

Technology Readiness

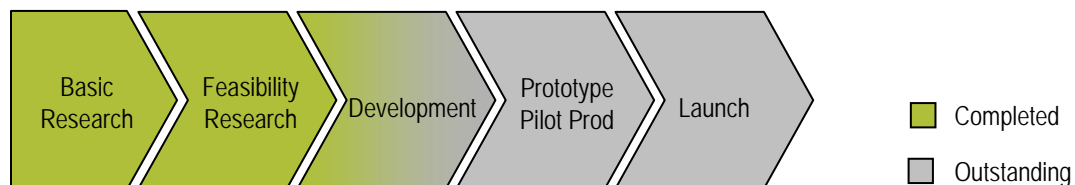

Carbon fiber precursor from modified textile PAN (polyacrylonitrile)

Estimated Time to Market

- 3-5 years

Estimated Commercialization Cost (2M lbs/yr)

- \$35M facility (\$15 Precursor, \$20M Conversion)

<u>Customer</u>	<u>Partner</u>	<u>Successful Demonstration</u>
OEMs*	Laboratory	Laboratory
Automotive Supplier*	Forrest Products Co.	Commercially – high strength – not low cost

*Potential

Commercialization Opportunities: Low-cost Carbon Fiber



- **PROBLEM:** Carbon fiber can be used in production of strong, lightweight structures but at current price of \$10–\$30/lb is too expensive for many energy-efficiency and renewable energy applications
- **DESCRIPTION OF INVENTION/TECHNOLOGY:** Technologies under development address cost reduction opportunities from feedstock materials to individual process stages.
 - Feedstock developments include low-cost textiles and renewable lignin, and are nearing pilot production stage
 - Processing developments include thermo-chemical stabilization methods, rapid oxidation processes, and microwave-assisted plasma carbonization methods are in early development stage
- **IMPACT:** Achieving production cost target of \$5–\$10/lb will make carbon fiber composites viable for high-volume energy-efficiency and renewable energy applications that can make significant contributions to reducing oil imports and consumption
 - Significant use of carbon fiber composites could reduce vehicle mass by up to 40 percent and result in up to 25 percent increase in fuel economy
 - Carbon fiber's superior properties allow for, e.g., more efficient wind turbine blades
- **IP POSITION:** Three patents issued; five patents filed; 11 disclosures
- **TECHNOLOGY STATUS/INVENTIONS:**
 - Melt-spinnable lignin precursors
 - Removal of carbohydrates from lignin
 - Production of activated carbon from lignin
 - Microwave-assisted plasma carbonization
 - Diagnostic monitoring of carbon fiber processing
 - Rapid thermo-chemical stabilization
 - Plasma oxidation
 - Electromagnetic processing of carbon fiber
 - Fiber surface activation
 - Fiber surface topography
 - Polyolefin precursors
 - Nano-reinforced carbon fiber



Commercialization Opportunities:

Triple Buss DC to DC Converter for Hybrid Electric and Fuel Cell Vehicles

• Description

- Integrated bidirectional DC-DC converter to interconnect the three voltage-buss nets

• Impact

- Reduce component count by more than 50 percent.
- High efficiency > 95 percent
- Easily adaptable to future vehicle power nets

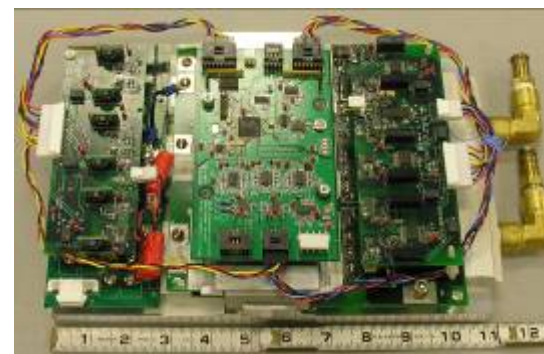

• Technology Readiness

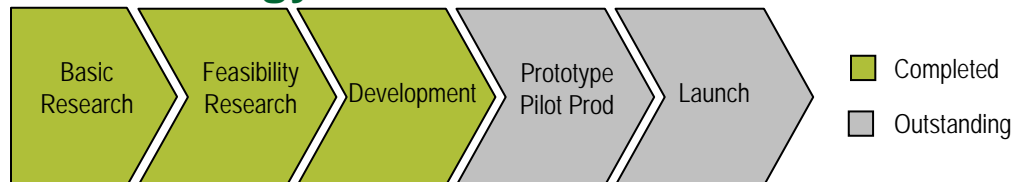

• Estimated Time to Market

- ORNL concept is ready for transition to industry
- 2-4 years

• Estimated Commercialization Cost

- \$ 5 million

<u>Customer</u>	<u>Partner</u>	<u>Successful Demonstration</u>
Automotive supplier of electronic devices*	Laboratory*	Laboratory

*Potential

Triple Buss DC to DC Converter for Hybrid Electric and Fuel Cell Vehicles



- **PROBLEM:** Hybrid electric and fuel cell vehicles require multiple voltage nets to efficiently and economically deliver electrical power to a variety of loads. A high voltage buss is needed for the traction system along with isolated 14 V and 42 V power nets for accessory loads.
- **DESCRIPTION OF INVENTION/TECHNOLOGY:** To reduce component count, size, cost, and volume, the Oak Ridge National Laboratory has developed an *integrated bidirectional DC-DC converter* to interconnect the three voltage-buss nets. The converter is based on a dual half-bridge connected through a high-frequency transformer:
 - Employs only four power switching devices per converter module
 - Soft-switching accomplished with power device's parasitic capacitances and leakage inductance, without additional switches or passive components
- **IMPACT:**
 - Reduction of component count by more than 50 percent
 - Galvanic isolation between the low and high voltage nets
 - High efficiency (>95 percent)
 - High power density (>2.7 kW/L)
 - Easy adaptation to future vehicle power nets
 - Suitable for modular, power-scalable configurations
- **IP POSITION:** One patent awarded, technology available for licensing
- **TECHNOLOGY STATUS:**
 - Concept proven through prototype build and test
 - Technology is available now
 - Special needs to implement: None

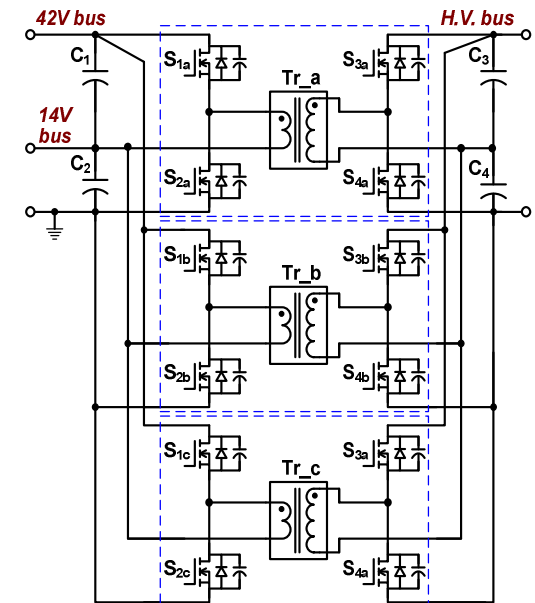



Commercialization Opportunities:

Current Source Inverter for Hybrid Electric and Fuel Cell Vehicles

Description

- A new inverter topology based on a current source inverter to relieve cost, size, and technology barriers

Impact

- Increased reliability
- Improved efficiency
- Boosted output

Technology Readiness

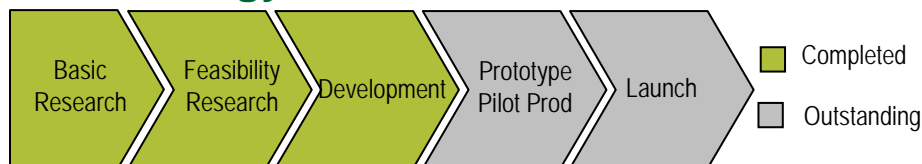

Estimated Time to Market

- 2-3 years

Estimated Commercialization Cost

- \$1M (to completely build and test a prototype), no industry partner involved at present (assume additional costs for packaging and automotive qualification in order to commercialize and deploy)

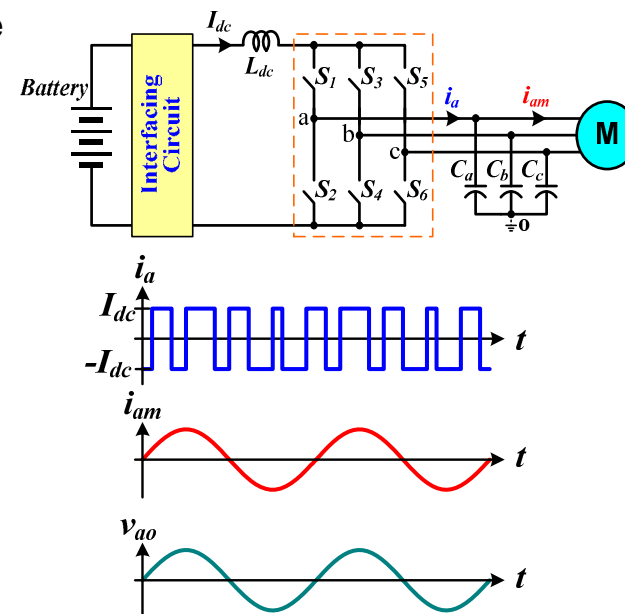

Topology of the proposed current source inverter yields sinusoidal output voltage and current waveforms.

*Potential

<u>Customer</u>	<u>Partner</u>	<u>Successful Demonstration</u>
Automotive supplier of electronic devices*	Laboratory	Laboratory



Current Source Inverter for Hybrid Electric and Fuel Cell Vehicles

- **PROBLEM:** Electric and hybrid electric vehicle inverters operate from a DC voltage source (batteries) which presents several drawbacks:
 - Requires a very high performance direct-current buss capacitor bank that is costly and bulky
 - Reliability is limited by the capacitors and possible shoot through of the phase leg switches
 - Steep rising and falling edges of the output voltage generates high electromagnetic interference - resulting in high stress on the motor insulation, high frequency losses in the copper windings and iron cores of the motor, and leakage currents that erode the bearings over time
 - Capacitor temperature limitations present a significant hurdle to operating in high-temperature environments
- **DESCRIPTION OF INVENTION/TECHNOLOGY:** A new inverter topology based on a current source inverter is under development at Oak Ridge National Laboratory to eliminate or significantly relieve these problems.
 - No buss capacitors and uses only three small filter capacitors
 - Fewer components, more fault tolerance and increased reliability
 - Enables higher motor speeds allowing inverter to output rated voltage over a wider discharge window
- **IMPACT:** Advantages translate into a significant reduction in inverter cost and volume, much higher constant power speed range, and improved motor efficiency and lifetime.
- **IP POSITION:** Patent filed, technology available for licensing.
- **TECHNOLOGY STATUS:** Completed simulation study and proved the concept. Developed an optimum PWM method and a strategy for maximum torque per amp control of IPM motors. A 55 kW prototype is undergoing fabrication and testing.



Commercialization Opportunities:

Direct Backside Jet Cooling for Power Electronics

• Description

Heat sink for liquid cooled power electronics. Enhanced heat transfer is obtained through jets directly impinging on the backside of the DBC (direct bond copper) layer.

• Impact

- Domestic transportation market
- High-power power electronics where space is a premium

• Technology Readiness

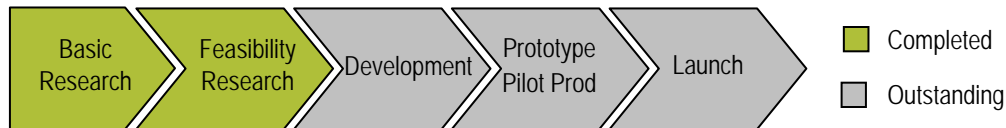

• Estimated Time to Market

- 2 to 4 years

• Estimated Commercialization Cost

- \$10M-\$20M

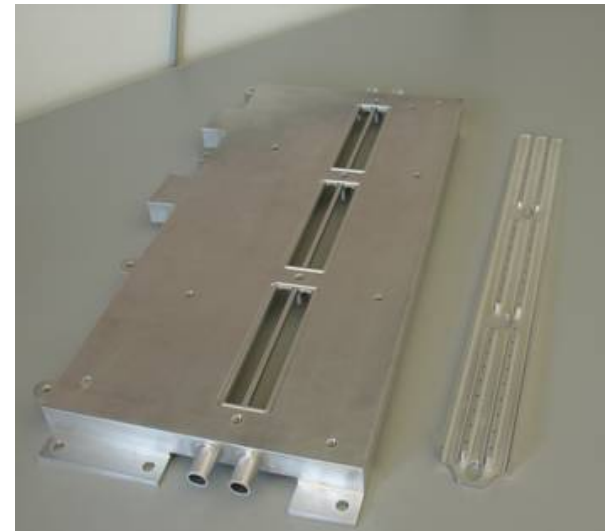

*Potential

<u>Customer</u> Automotive supplier of electronic devices*	<u>Partner</u> Laboratory	<u>Successful Demonstration</u> Laboratory
---	------------------------------	---

Direct Backside Jet Cooling for Power Electronics



- **PROBLEM:** Power electronics are a fundamental component of all electrical advanced vehicle systems (HEVs, PHEVs, FCVs, EVs). However, cost, weight, volume, and reliability need to improve to help the business case for these vehicle systems.
- **DESCRIPTION OF INVENTION/TECHNOLOGY:** The technology is a heat sink for power electronics that uses jets of liquid coolant that impinge on the backside of the power electronics DBC (direct bond copper).
- **IMPACT:** The direct backside cooling concept allows for a smaller, lighter power electronics package for the same power levels as a conventional power electronics package using pin-fin liquid cooling. In addition, we believe that the total cost of the system can be lowered by enabling the use of less volume of expensive materials and enabling the use of lower cost materials.
- **IP POSITION:** NREL Patent number 7,190,581.
- **TECHNOLOGY STATUS:** Various aspects of the direct backside cooling concept has been examined analytically using finite element and computational fluid dynamics simulations. A prototype has been built and tests are currently under way to show the benefits of this technology. We plan to further investigate the use of surface enhancements to further increase the heat transfer capability of this technology for negligible increase in pressure drop.

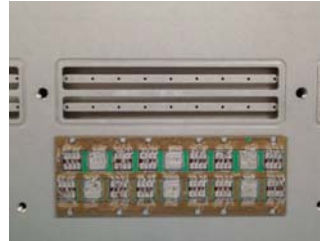
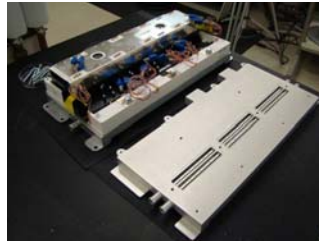
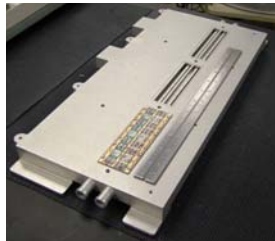

Green Tire and “Smart” Monitoring System



• Description

New tire design based upon new material formulations including “smart” piezoelectric temperature compensated pressure monitoring.

• Impact

- Domestic transportation market
- Military vehicles

• Technology Readiness

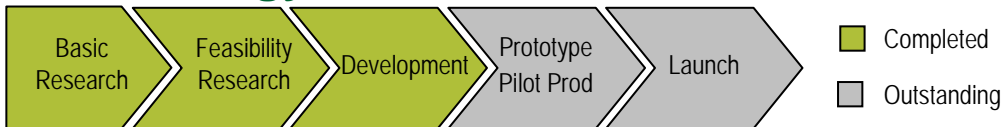

• Estimated Time to Market

- 2 to 4 years

• Estimated Commercialization Cost

- \$15-30M

<u>Customer</u>	<u>Partner</u>	<u>Successful Demonstration</u>
Tire Manufacturers	Laboratory	Laboratory
OEMs*	Amerityre	Commercial

Green Tire and “Smart” monitoring System



- **PROBLEM:** The transportation industry is faced with increasing pressures to improve fuel economy. It has been shown that 35 to 50 percent improvement in rolling resistance results in a 5 to 10% fuel economy improvement.
- **DESCRIPTION OF INVENTION/TECHNOLOGY:** NREL, in partnership with Amerityre (AMTY) Corporation, is developing a “green” synthetic material tire with the potential of a smart tire pressure monitoring system.
- **IMPACT:** A fuel savings of five percent across the fleet represents 20 million gallons per day or over 7 billion gallons per year and 60 million metric tons per year of CO₂. Since most tires are replaced every three to four years this could have a near term impact on both fuel savings and reduction in green house gases. In addition, a new method for this “green” tire production uses about 1/10th the energy of conventional tires representing on the order of 160 billion kWh of energy savings over the current annual tire production volume.
- **IP POSITION:** Amerityre and NREL have several patents including Record of Invention disclosures (ROI) on green tire and smart tire monitoring system
- **TECHNOLOGY STATUS:** Amerityre have built and tested polyurethane car tires. These have recently passed the Federal Motor Vehicle Safety Standard (FMVSS) 139 test criteria (the only polyurethane tire to pass). Prototype manufacturing technologies have been demonstrated a low volume rates (one tire every two days) and scaled up designs for production rates for one tire per minutes have been proposed.

Agenda



- Industry Landscape
- Program Objectives
- Technology Commercialization Opportunities
- **Unexploited Investment Gaps**

Large automotive market – over 17 million new vehicles sold annually

Gap 1: Battery Development and Manufacturing



- **Gap Overview**
 - Develop electric drive-train energy storage technology with a 10+ year life that enables a 40 mile all-electric range and costs \$3,400
- **Market Drivers?**
 - Rising gasoline prices create a business case for vehicles that operate in an all electric mode
- **Why Does the Gap Exist?**
 - Low fuel prices have been a barrier to market introduction of higher cost electric drive technologies
- **Specific Investment Opportunities**
 - Battery materials manufacturing facilities
 - Battery assembly facilities
 - Battery recycling and materials recovery facilities
- **Other Business Synergies**
 - Energy storage for wind, solar
 - Energy storage for utility applications
 - Energy storage for home/business
- **Big Picture Opportunities?**
 - Opportunities may exist for investment in lower volume (10,000+ units) domestic manufacturing of maturing hybrid and electric vehicle battery technologies that meet plug-in and electric vehicle performance requirements



Lithium-Ion cells

Large automotive market – over 17 million new vehicles sold annually

Gap 2: Lightweighting



- **Gap Overview**
 - Develop rapid, high-yield lightweight materials manufacturing processes.
- **Market Drivers?**
 - Rising gasoline prices create a business case for lighter vehicles to increase fuel efficiency
- **Why Does the Gap Exist?**
 - Historically low prices of fuel and steel
 - Steel/plastics are proven materials and adequate in past markets
- **Specific Investment Opportunities**
 - Automotive supplier sector
 - Carbon fiber production facilities
 - Recycling and recovery facilities
- **Other Business Synergies**
 - Wind turbine blades
 - Consumer goods
 - Civil infrastructure
- **Big Picture Opportunities?**
 - Opportunities exist for investment in high volume/low-cost manufacturing of lightweight components to increase efficiency and/or offset the additional weight of other technologies, e.g. batteries, electric power trains, and fuel cells



Carbon Fiber Spinning from Lignin ORNL

Large automotive market – over 17 million new vehicles sold annually

Gap 3: Waste Heat Recovery (Thermo-electrics)



- **Gap Overview**
 - Develop technology that converts waste heat to electricity, current engines waste 60 to 70 percent of energy as heat
- **Market Drivers**
 - Rising gasoline prices and existing or impending regulation of greenhouse gas emissions
- **Why Does the Gap Exist?**
 - Solid state technology slow to mature for automotive use
 - Difficulty in raising thermoelectric cell efficiencies
- **Specific Investment Opportunities**
 - Few manufactures
 - Large automotive and truck market
 - Broad applications across all combustion powered vehicles
 - Replace refrigerant gas air conditioning, more efficient and doesn't use greenhouse gas refrigerant.
- **Other Business Synergies**
 - Computer industry
 - Refrigeration industry
 - Electrical generation from solar heating
- **Big Picture Opportunities?**
 - Opportunities exist in waste heat recovery across multiple sectors



Exhaust System
Waste Heat



Sample Thermo Electric Device