

HYDROPOWER

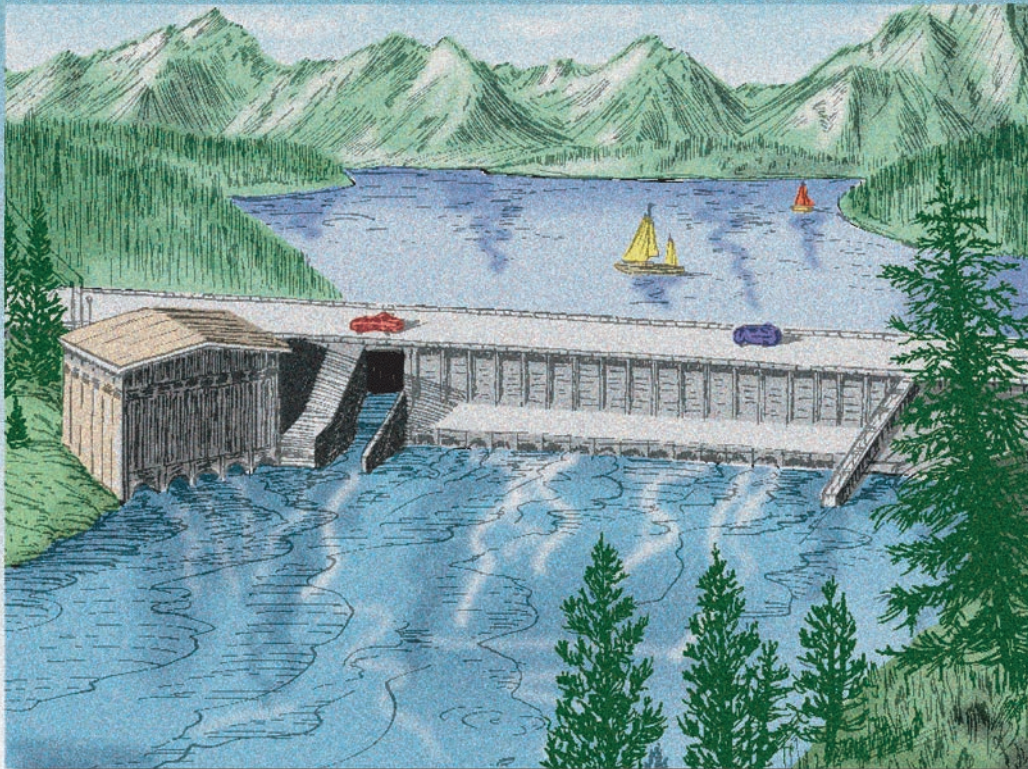

PARTNERSHIP WITH THE ENVIRONMENT

United States Department of Energy



HOW HYDROPOWER WORKS

The hydrologic cycle—water constantly moves through a vast global cycle, in which it evaporates from lakes and oceans, forms clouds, precipitates as rain or snow, then flows back to the ocean. The energy of this water cycle, which is driven by the sun, is tapped most efficiently with hydropower.

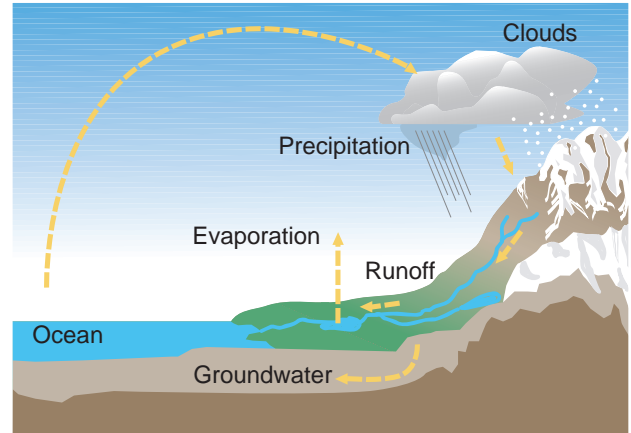

Types of Hydropower Facilities

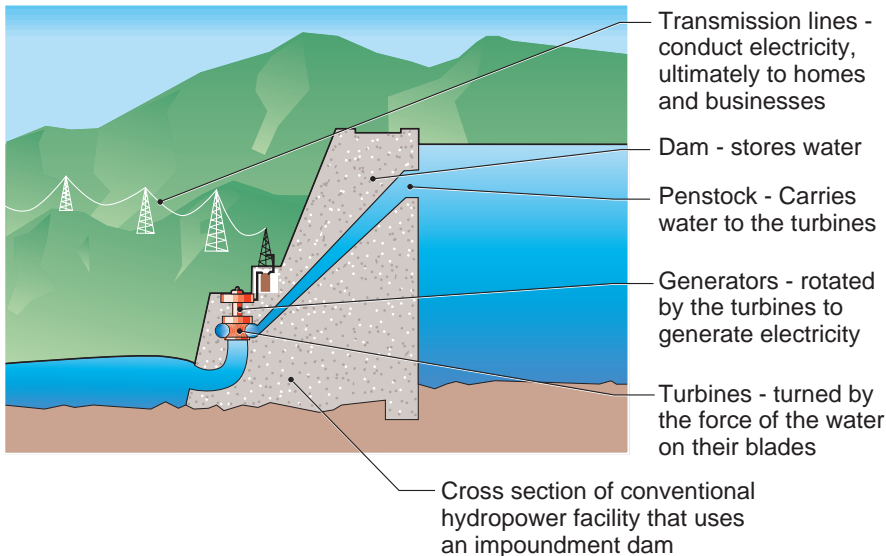

Impoundment hydropower—uses a dam to store water. Water may be released either to meet changing electricity needs or to maintain a constant reservoir level.

Pumped storage—pumps water from a lower reservoir to an upper reservoir at times when demand for electricity is low. During periods of high electrical demand, the water is released back to the lower reservoir to generate electricity.



Diversion projects—channel a portion of the river through a canal or a penstock and may require a dam. The adjacent project did not require a dam.

Run-of-river projects—utilize the flow of water within the natural range of the river, requiring little or no impoundment. Run-of-river plants can be designed using large flow rates with low head or small flow rates with high head.



Microhydropower projects—produce 100 kilowatts (kW) or less. Microhydro plants can utilize low heads or high heads.

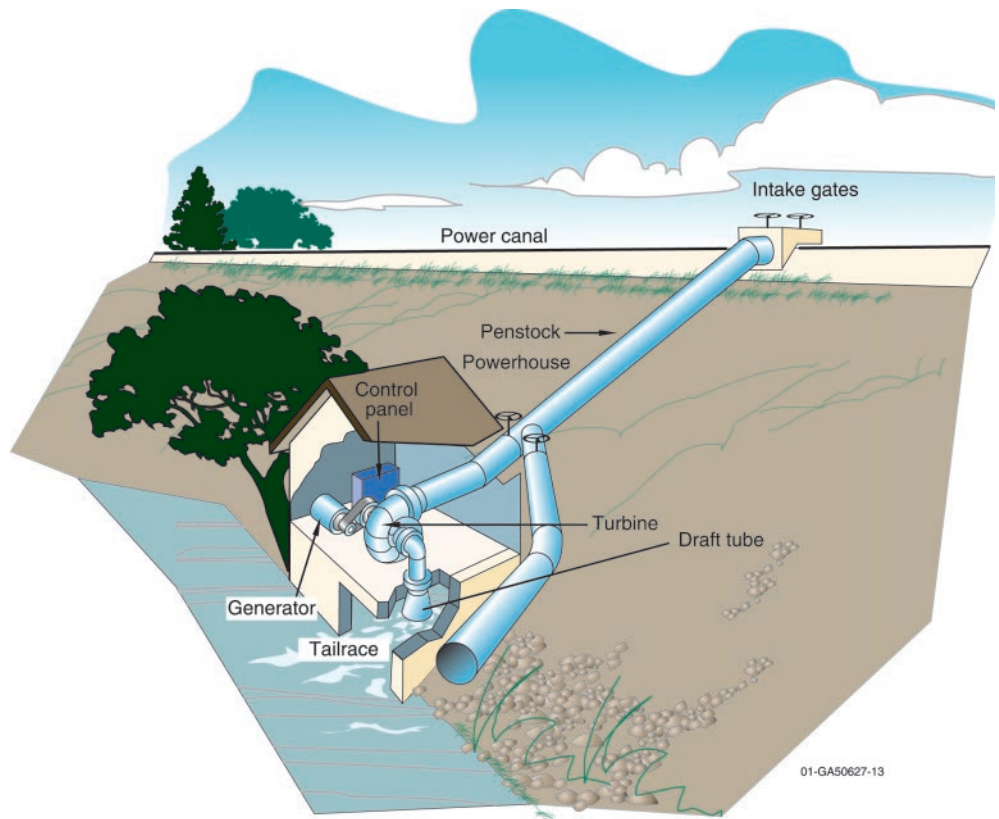

HYDROPOWER FACTS

Primary Purpose or Benefit of U.S. Dams

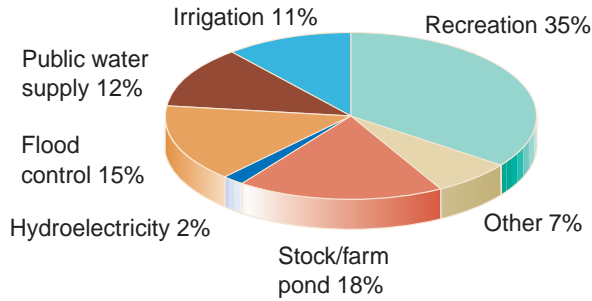

Source: U.S. Army Corps of Engineers, National Inventory of Dams

U.S. Net Generation of Electricity (Based on 2000 total kilowatt-hours generation)

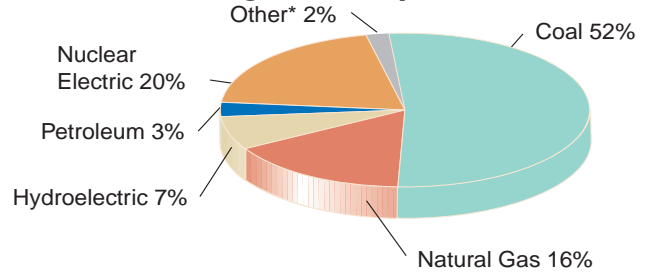

Source: EIA, Electric Power Monthly, March 2001, Tables 3 & 58.
* Other includes geothermal, biomass, wind, photovoltaic, and solar thermal. Includes utility and nonutility generation.

Top Hydroelectric Generating Countries, 1998

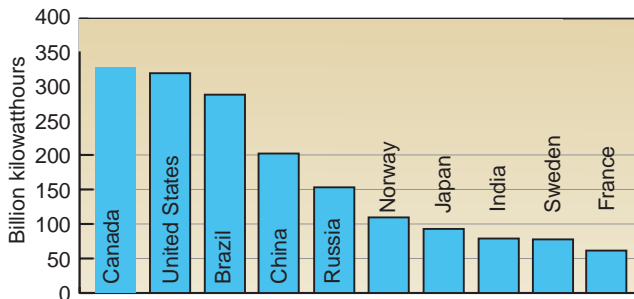

Source: EIA, Annual Energy Review 1999, July 2000, Table 11.15

Net Generation by Renewables (2000 utility & nonutility total generation)

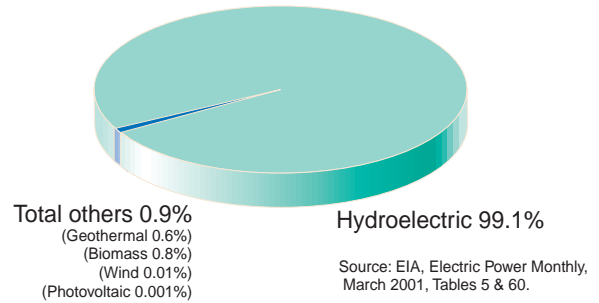

Source: EIA, Electric Power Monthly, March 2001, Tables 5 & 60.

Costs and Environmental Benefits

U.S. Technology

Capital cost \$/kW	\$1,700-2,300/kW capacity ¹
Operation cost per kWh	4.05 mills (0.4¢) ²
Maintenance cost per kWh	2.62 mills (0.3¢) ³
Total cost per kWh	23.57 mills (2.4¢) ⁴
Operating life	50+ years ⁵
Capacity factor	40-50% ⁵
Average size	31 MW ⁶

U.S. Contribution

U.S. developed capacity (1999)	79,700 MW ⁶
Energy production (2000)	269,034 million kWh ⁷
Percent of U.S. total electricity (2000)	7.1% ⁸
Capital investment	\$159 billion ⁹
Average annual revenue	\$18 billion ¹⁰
Average annual avoided oil equivalent	1.3 billion barrels/year ¹¹
Average daily avoided oil equivalent	3.7 million barrels/day ¹²

Avoided sulfur dioxide emissions (1993)	2,052,000 tons of SO ₂ ¹³
Avoided nitrogen oxide emissions (1993)	832,000 tons of NO _x ¹³
Avoided carbon dioxide emissions (1993)	276,207,000 tons of CO ₂ ¹³ (75 million tons of carbon equivalent) ¹⁴

International Contribution

Hydroelectricity provides 18.8% of the world-wide net generation of electricity (1998)¹⁴
Hydroelectricity provides 21.6% of the world-wide electricity capacity (1998)¹⁴

Hydroelectric Net Generation by State (January - December 1999)

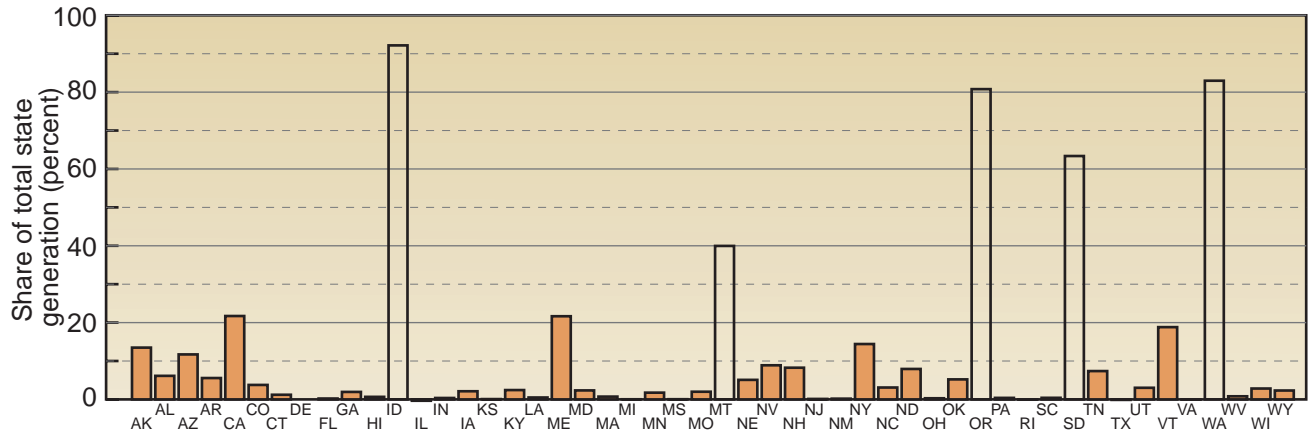

Source: EIA, *Electric Power Annual, Volume 1, August 2000*. Tables A7 & A12. Includes utility and nonutility generation.

Developed Hydropower Capacity by State - Megawatts

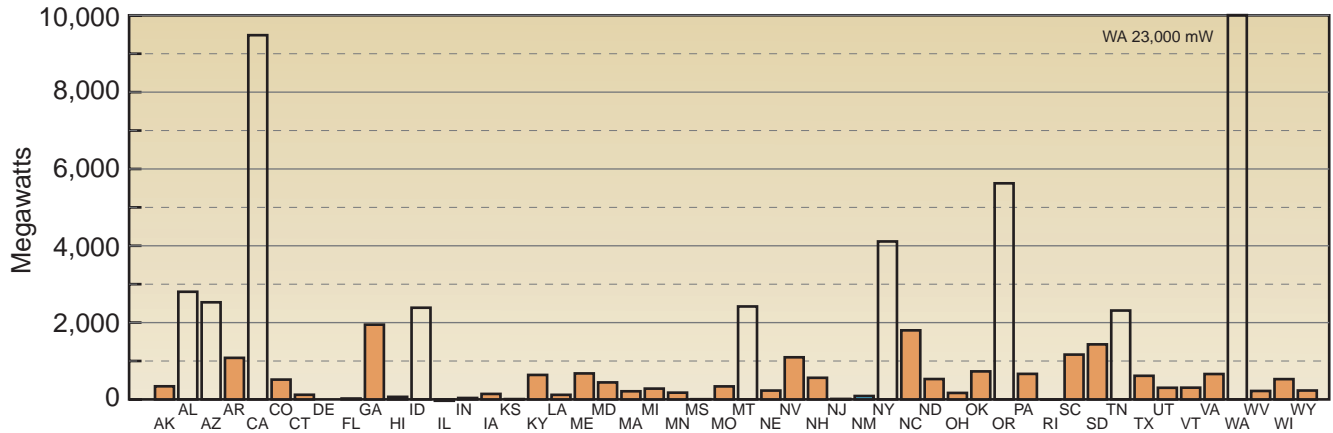

Source: Federal Energy Regulatory Commission (FERC) - Hydropower Resources Assessment database.

Undeveloped Hydropower Potential by State - Megawatts

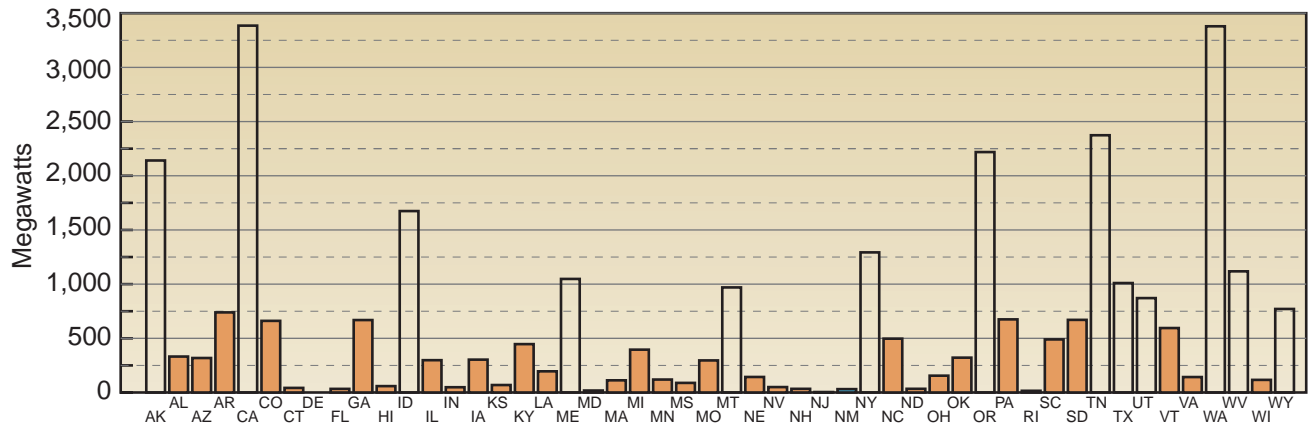

Source: Hydroelectric Power Resources Assessment database (FERC) and Hydropower Evaluation Software (INEEL). DOE has modeled the undeveloped conventional hydropower potential in the United States. This does not include developed capacity. Various state agencies have reviewed the modeled results and provided input. The 50-state undeveloped conventional hydropower potential is approximately 30,000 MW. The model includes environmental, legal, and institutional constraints to development.

HYDROPOWER ENVIRONMENTAL ISSUES

Current hydropower technology, while essentially emission-free, can have undesirable environmental effects, such as fish injury and mortality from passage through turbines, as well as detrimental changes in the quality (dissolved gases) of downstream water. Advanced hydropower turbine technology could minimize the adverse effects yet preserve the ability to generate electricity from an important renewable resource.

The goal of the U.S. Department of Energy's (DOE's) Advanced Hydropower Turbine System Program is to develop technology that will allow the nation to maximize the use of its hydropower resources while minimizing adverse environmental effects. Conceptual designs of environmentally friendly hydropower turbines have been completed under the DOE-industry program (see following pages).

Potential injury mechanisms caused by turbine passage have been identified (see below). Research is being performed to understand the effects of these injury mechanisms on fish and to develop methods for reducing their severity.

Potential Benefits of Advanced Turbine Technology

Reduced fish mortality: Advanced turbine technology could reduce fish mortality resulting from turbine passage to less than 2%, in comparison with turbine-passage mortalities of 5 to 10% for the best existing turbines and 30% or greater for some turbines.

Improved compliance with water quality standards: Advanced turbine technology would maintain a downstream dissolved oxygen level of at least 6 mg/L, ensuring compliance with water quality standards.

Reductions in CO₂ emissions: The use of environmentally friendly turbine technology would help reverse the decline in hydroelectric generation and reduce the amounts of CO₂ and other greenhouse gases emitted by consumption of fossil fuels.

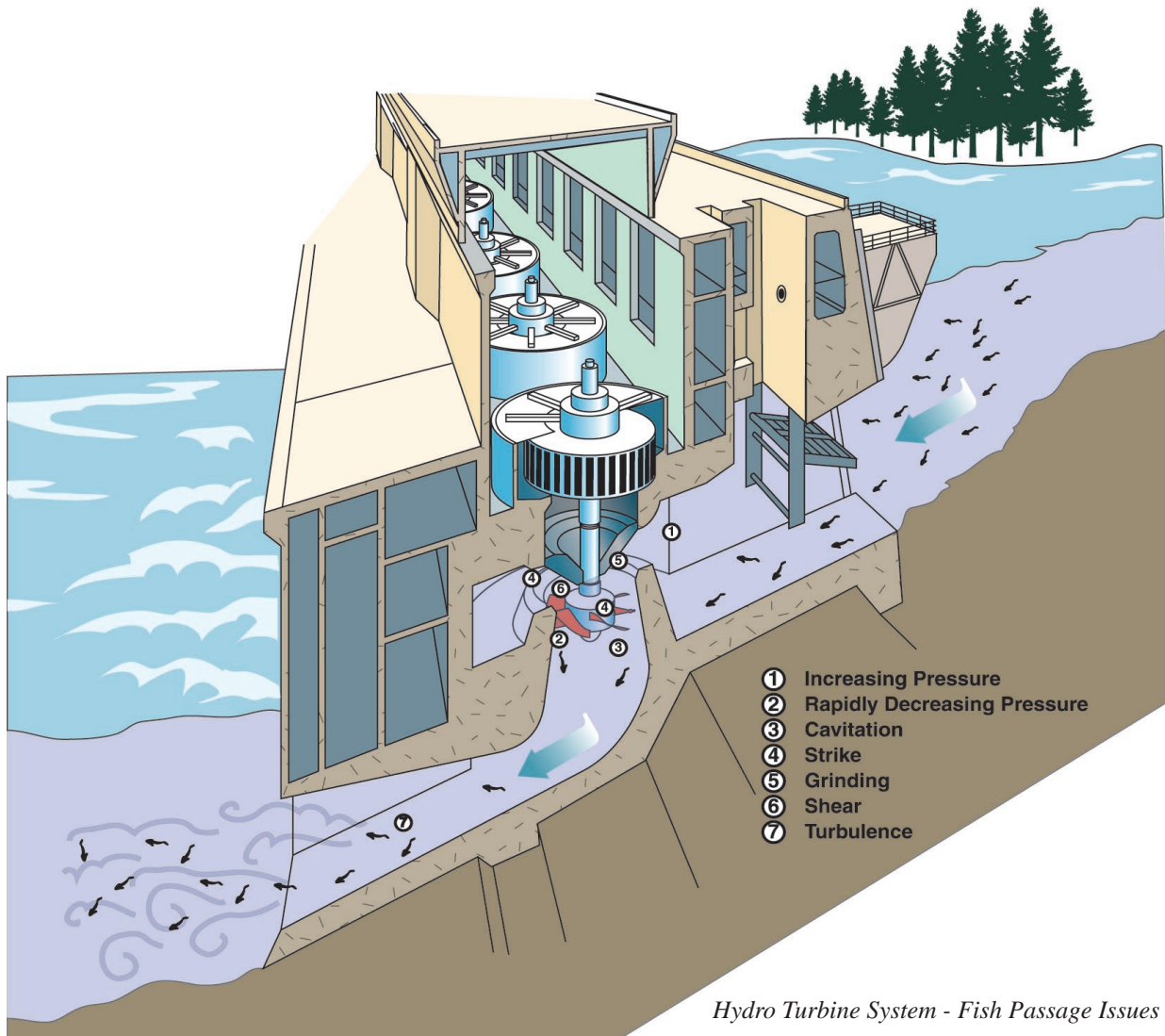

ADVANCED HYDROPOWER TURBINE SYSTEM PROGRAM

DOE, with matching funds from the Hydropower Research Foundation, Inc., awarded two contracts for developing conceptual designs for environmentally friendly turbines. Contracts were awarded to the Alden Research Laboratory/Northern Research and Engineering Corporation team and Voith Hydro team consisting of Normandeau Associates, TVA, Harza Engineering Company, and Georgia Institute of Technology.

The Alden Design Team:

- Developed a set of design criteria that are related to fish injury (number of blades, pressure, etc.)
- Designed a turbine runner to minimize both fish injuries and efficiency losses.

The final design uses only two long blades, which are wrapped around the central hub in a corkscrew shape to gradually reduce pressure and minimize blade-induced injuries.

The Alden team is building a one-third scale proof of concept model that will be tested in a laboratory environment. Tests will verify biological and engineering performance predictions.

ARL/NREC Fish-Friendly Hydroturbine

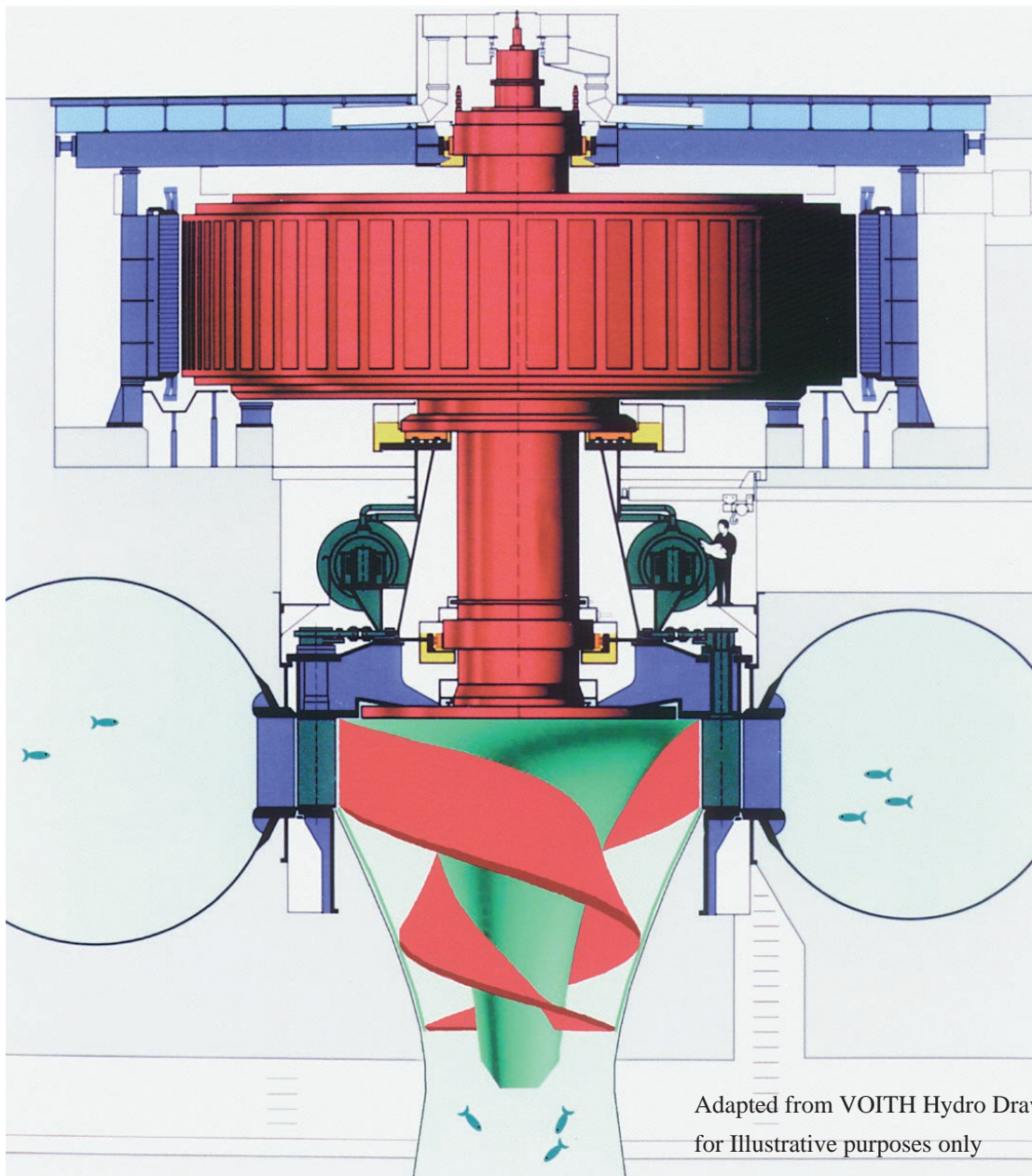

The Voith Design Team:

- Developed concepts for improving fish passage which include special blade shapes, oil and grease reduction, smooth surfaces, and reduction in the space between the turbine runner and the hub.
- Developed a design concept for dissolved oxygen improvement that includes an aerating runner and advanced control systems.
- Developed recommendations for future research to improve the knowledge of the physical stresses experienced by fish in the turbine system.

Voith is currently testing some of the features developed for improving fish passage at sites in the Pacific Northwest.

Typical Existing Kaplan Turbine

High blade tilt

1. Gate overhangs top of discharge ring
2. Minimum blade entrance edge gap at hub
3. Minimum blade discharge edge gap at hub
4. Small gap at blade entrance edge at discharge ring
5. Overhanging blade with trailing edge (TE) gap at discharge ring

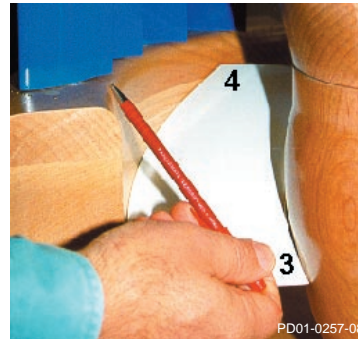
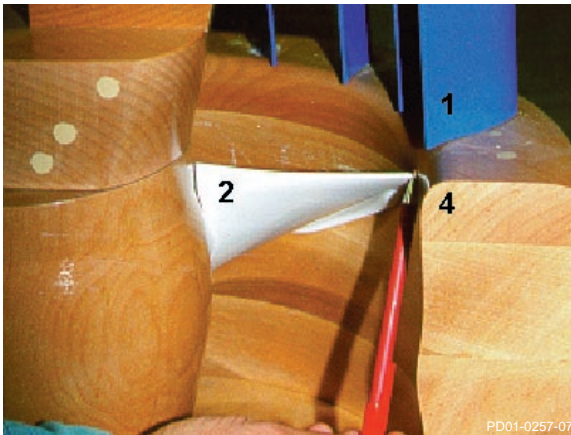

Minimum Gap Kaplan* Rehabilitation

High blade tilt position, high discharge

1. No gate overhang
2. No leading edge gap at hub
3. No leading edge gap at discharge ring
4. No TE gap at hub
5. No overhang or gap at discharge ring at blade training edge

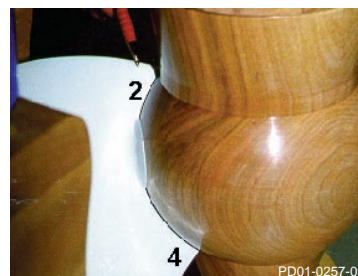
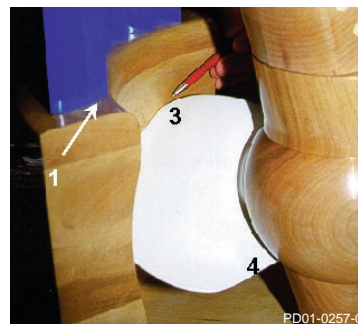

*Patent Pending

Biological Research

The DOE Hydropower Program supports a number of research projects that contribute to its goal of improving the environmental performance of hydropower technology. Most of these enable the development of advanced turbines by producing new understanding of the stresses that kill or injure fish. Some of the complementary efforts to develop new understanding of effects on turbine-passed fish are the following:

1. Laboratory studies of the response of fish to turbine-passage stress mechanisms (using live fish)
2. Field measurements of the physical conditions within portions of the turbine (using instrumented sensor fish), and
3. Application of advanced computational techniques to describe the hydraulic environment that fish experience (using virtual fish).

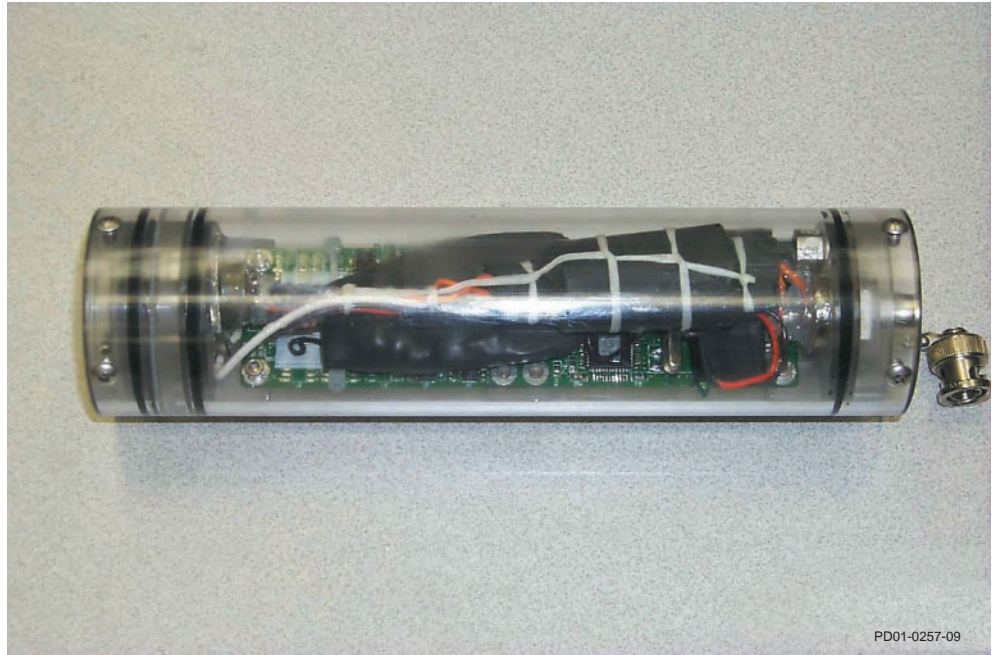

Sensor fish prototype device

HYDROELECTRIC'S HISTORICAL PROGRESSION

- Used by the Greeks to turn water wheels for grinding wheat into flour, more than 2,000 years ago
- 1775, U.S. Army Corps of Engineers founded, with establishment of Chief Engineer for the Continental Army.
- July 1880, Michigan's Grand Rapids Electric Light and Power Company, generating electricity by dynamo, belted to a water turbine at the Wolverine Chair Factory, lit up 16 brush-arc lamps.
- 1881, Niagara Falls, city street lamps powered by hydropower.
- 1886, about 45 water-powered electric plants in the U.S. and Canada.
- 1887, San Bernardino, Ca., first hydroelectric plant in the west.
- 1889, 200 electric plants in the U.S. that use water-power for some or all generation.
- 1901, first Federal Water Power Act.
- 1902, Bureau of Reclamation established.
- 1907, 15% of electric generating capacity in U.S. was provided by hydropower.
- By 1920, 25% of U.S. electrical generation was hydropower.
- 1920, Federal Power Act establishes Federal Power Commission authority to issue licenses for hydro development on public lands.
- 1933, Tennessee Valley Authority established.
- 1935, Federal Power Commission authority extended to all hydroelectric projects built by utilities engaged in interstate commerce.
- 1937, Bonneville Power Administration established.
- 1938, Bonneville Dam, first Federal dam on the Columbia River.
- By 1940, 40% of electrical generation was hydropower.
- Conventional capacity in the U.S. tripled between 1921 and 1940, almost tripled again between 1940 and 1980.
- Currently, about 7% of U.S. electricity comes from hydropower. Today there is about 80,000 MW of conventional capacity and about 18,000 MW of pumped storage.

NOTES

- 1 Capital cost estimate based on capital costs of 21 hydroelectric plants that commenced operation during 1993. The median value is \$2,000/kW. The weighted mean value of \$2,363/kW is influenced by a single plant cost of \$4,778/kW and two other plants with costs of over \$3,000/kW. The plants range in capacity size from 125/kW of installed capacity to 32.4 MW, averaging 4.81 MW of capacity. The capital cost per kW in capacity range is \$735 to \$4,778. The capital cost per kW for 9 of the 21 plants is within + \$300 of \$2,000. Determining the average capital cost is difficult due to the many various types of hydropower sites (high-low heads and/or high-low flows) and the myriad of possible environmental requirements.
- 2 Operation cost includes expenses associated with operating a facility such as supervising and engineering expenses, and includes rent expenses. Source: Energy Information Administration (EIA), Financial Statistics of Major U.S. Investor-Owned Electric Utilities 1996, December 1997 Table 14. Average Power Production Expenses for Plants Owned by Major U.S. Investor-Owned Electric Utilities, 1992-1996 (averages provided).
- 3 Maintenance cost includes labor, materials, and other direct and indirect expenses incurred for preserving the operating efficiency and/or physical condition. Source: same as Note 2.
- 4 Sum of operation, maintenance and capital costs. Capital cost based on \$2,000/kW cost, 45% plant factor, and 30 years of operation.
 $1 \text{ kW} \times 24 \text{ hours} \times 365 \text{ days} \times 45\% \times 30 \text{ years} = 118,260 \text{ kWh}$
 $\$2,000 \div 118,260 \text{ kWh} = 16.9 \text{ mills}$
 $4.05 \text{ mills} + 2.62 \text{ mills} + 16.9 \text{ mills} = 23.57 \text{ mills}$
- 5 Source: Western Area Power Administration and U.S. Department of Energy, DSM Pocket Guidebook, Volume 5: Renewable and Related Technologies for Utilities and Buildings. Publication date unknown, Table R-3.
- 6 Annual Energy Review 1999, July 2000. Table 8.5.
- 7 U.S. electric utility net hydroelectric generation 247,566 million kWh (EIA, Electric Power Monthly, March 2001. Table 3). Nonutility hydroelectric generation of 21,468 million kWh (EIA, Electric Power Monthly, March 2001, Table 58).
- 8 Same source as Note 7.
- 9 U.S. developed capacity (79,700 MW) x Capital cost \$/kW (\$1,700-2,300) = \$159 billion
- 10 Average annual energy production (269,034 million kWh) x Average revenue per kWh (\$0.0666). Source: EIA, Electric Power Monthly, March 2001, Table 52.
- 11 Assumes hydroelectric generation of 269,034 million kWh, approximate thermal electric equivalent of 10,338 Btu per kWh (EIA, Monthly Energy Review, March 1998, Table A8), and approximate crude oil heat content of 6.212 million Btu per barrel (EIA, Monthly Energy Review, March 1998, Table A3). $269,034 \text{ million kWh} \times 10,338 \text{ Btu} \div 6.212 \text{ million Btu} \times 3$ (assumes petroleum plant energy efficiency of 33%) = 1,343,177,797 (1.3 billion)
- 12 $1,343,177,797 \div 365 = 3.7 \text{ million}$
- 13 Assumes 1993 U.S. electric utility fossil-fueled net generation of 1,973,000 million kWh, sulfur dioxide (SO₂) emissions of 14,428,000 tons (2,000 lb), nitrogen oxide (NO_x) emissions of 5,848,000 tons, and carbon dioxide (CO₂) emissions of 1,942,386,000 tons (EIA, Electricity Generation and Environmental Externalities: Case Studies, September 1995, Table 1). Assumes 1993 hydroelectric generation of 280,609 million kWh (EIA, Electric Power Monthly, February 1996, Table 5). Assumes hydroelectric is 14.22% ($280,609 \div 1,973,000$) of fossil-fueled generation, so the use of hydroelectric generation avoids the creation of an additional 14.22% in emissions if fossil-fueled generation was used instead of hydroelectric generation.
 $14,428,000 \times 14.22\% = 2,052,000 \text{ tons of SO}_2$
 $5,848,000 \times 14.22\% = 832,000 \text{ tons of NO}_x$
 $1,942,386 \times 14.22\% = 276,207,000 \text{ tons of CO}_2$
- 14 $276,207,000 \text{ tons} \div 3.67 = 75 \text{ million tons carbon equivalent.}$
- 15 Source: EIA, Annual Energy Review 1999, July 2000, Tables 11.15 and 11.16.

FOR MORE INFORMATION:

Peggy Brookshier
U.S. Department of Energy
Idaho Operations Office
850 Energy Dr., MS 1220
Idaho Falls, ID 83401-1563
(208) 526-1403
Fax (208) 526-5964
brookspa@id.doe.gov

John V. Flynn
U.S. Department of Energy
EE-12, Room 5H/048
1000 Independence Ave. SW
Washington, DC 20585
(202) 586-8171
Fax (202) 586-8185
john.flynn@hq.doe.gov

Garold L. Sommers
Idaho National Engineering and Environmental Laboratory
2525 Fremont Ave.
Idaho Falls, Id 83415-3830
(208) 526-1965
Fax (208) 526-0969
Sommergl@inel.gov

Glenn F. Cada
Environmental Sciences Division
Oak Ridge National Laboratory
P.O. Box 2008
Oak Ridge, TN 37831-6036
(865) 574-7320
Fax (865) 576-3989
gfc@ornl.gov

Michael J. Sale
Oak Ridge National Laboratory
Building 1505, MS 6036
Oak Ridge, TN 37831-6036
(865) 574-7305
Fax (865) 576-8543
jon@ornl.gov

Dennis D. Dauble
Pacific Northwest National Laboratory
P.O. Box 999
Richland, Wa 99352
(509) 376-3631
Fax (509) 373-1153
dd.dauble@pnl.gov

Thomas R. Murphy
Federal Hydro Projects
Bonneville Power Administration
P.O. Box 3621 (PGF-6th Floor)
Portland, OR 97208-3621
(503) 230-5527
Fax (503) 230-3752
trmurphy@bpa.gov

J. Mark Robinson
Director, Office of Energy Projects
Federal Energy Regulatory Commission
888 First Street, NE, HL-11
Washington, DC 20426
(202) 219-2700
Fax (202) 219-2152
mark.robinson@ferc.fed.us

Janet C. Herrin
Sr. Vice President
River Operations
Tennessee Valley Authority
400 West Summit Hill Dr.
Knoxville, TN 37901
(865) 632-6770
jcherrin@tva.gov

Deborah Linke
Manager, Power Resources Office
Bureau of Reclamation
P.O. Box 25007 D-5400
Denver Federal Center
Denver, CO 80225-0007
(303) 445-2923
Fax (303) 445-6471
dlinke@do.usbr.gov

Clare Perry
CENWD-NP-Pa
Public Affairs Office
U.S. Army Corps of Engineers
North Pacific Division
P.O. Box 2870
Portland, OR 97208
(503) 808-3710
Fax (503) 808-3713
clare.e.perry@usace.army.mil

Linda Church Ciocci
National Hydropower Association
1 Massachusetts Ave.
N.W., Suite 720
Washington, DC 20001
(202) 682-1700
Fax (202) 682-9478
nhalinda@aol.com

Jan Lee
Executive Director
Northwest Hydro Association
1201 Court St., NE Suite 303
Salem, OR 97301
(503) 363-0121
janlee@owrc.org

Visit our website:
<http://hydropower.inel.gov>

01-GA50627



June 2001